

CR, CRI, CRN, CRE, CRIE, CRNE custom-built pumps

50/60 Hz IEC



1. Introduction	4	Back-to-back seal arrangement	31
Customized CR pumps	4	CR pump with dosing pump in back-to-back seal arrangement	33
Pumps for specific requirements	4	CR pump with a pressure intensifier in back-to-back seal arrangement	34
Features and benefits	5	Tandem-seal arrangement	35
ErP-compliant.	5	Air-cooled top	37
Further documentation.	6	Magnetic-drive pump (MAGdrive)	40
2. Performance range	7	8. Pump	42
CR, CRI, CRN performance range	7	PN 25 and PN 40 pumps	42
3. Identification	9	Measurement of inlet pressure	42
Type key	9	Pumping of liquids of temperature as low as -40 °C	42
4. Applications	10	Carbon-free pumps	43
High-pressure applications	10	CRN all-stainless steel pumps	43
Hot-water applications	11	Surface treatment	44
Temperature control applications	12	CR low NPSH	46
Aggressive/hazardous liquids	13	Horizontal in-line pumps	47
Hygienic applications	14	Multistage horizontal end-suction pumps	53
Special installation requirements	15	Belt-driven pumps	55
Special applications	16	CR, CRI deep-well pumps	57
Intended use in the United Kingdom	16	Pump rubber parts	58
5. Accessories	17	Bearing flange	59
ATEX-approved dry-running protection	17	Support bearings	61
Venting valve with connecting pipe	18	Bearing material	61
Dosing pump system for barrier fluid	18	Pump head positions	62
Flushing-liquid tank for pumps with tandem seal arrangements	18	Customized nameplate	62
6. Motor	19	Dry-running protection	63
VIK-approved motors	19	Pipe connections	65
Tropicalised motors	19	Base plate for CR 95 with CR 90 footprint	71
cURus-, UR- and CSA-approved motors	19	9. Certificates	72
Energy	19	CR pumps with certificates	72
Other motor approvals	19	Pump performance testing	79
ATEX-approved pumps	20	Performance-test types for pumps	80
Special voltage	21	10. CRE pump solutions	82
Motor with multiplug connection	22	Customized CRE pump solutions	82
Motor with anti-condensation heater	23	Bluetooth	84
Motors with PTC sensors	24	Communication with CRE pumps	85
Motors with thermal switches	25	Industrial custom-built E-solutions	88
Oversize motors	26	11. How to read the curve charts	94
Undersize motors	26	Guidelines to curve charts	95
Alternative enclosure class (IP)	26	Guidelines to CR deep-well curve charts	96
Alternative terminal box positions	26	12. Performance curves	97
4-pole motors	27	CR deep-well	97
Permanent magnet motors	27	Low-NPSH pumps, 50 Hz	98
Motor efficiency classes	27	Low-NPSH pumps, 60 Hz	106
Other motor makes	27	CR pumps with 4-pole motor, 50 Hz	114
7. Shaft seals	28	CR pumps with 4-pole motor, 60 Hz	129
Shaft seal arrangements	28	13. Technical data	144
Shaft seal variants	28	Dimensional drawings for CR pumps	144
Overview of shaft seals	29	CR low-NPSH pump	149
Single-shaft seals	30		
Double-seal arrangements	30		

CR pumps with 4-pole motor	157
CR deep-well pumps	171
CR deep-well pumps, 50 Hz	171
CR deep-well pumps, 60 Hz	172
CRN pumps with magnetic drive	173
CR-H, CRN-H pumps	185
14. Motor data	191
2-pole motors for CR, CRI, CRN, 50 Hz	191
4-pole motors for CR, CRI, CRN, 50 Hz	192
2-pole motors for CR, CRI, CRN, 60 Hz	193
4-pole motors for CR, CRI, CRN, 60 Hz	194
15. Pumped liquids	195
List of pumped liquids	196
16. Grundfos Product Center	198
Grundfos GO	199
17. Document quality feedback.	200

1. Introduction

This catalogue gives an overview of some of the customized CR pump solutions offered by Grundfos. If the catalogue does not provide a solution to your specific pumping needs, contact us with a detailed description of your application.

Related information

[Further documentation](#)

Customized CR pumps

We offer a wide range of customized variants of the range for a variety of demanding industrial applications.

With these multistage in-line pumps, based on the well-known range, we meet the customers' need for pumps capable of handling special installation requirements, and the following media:

- high-temperature liquids
- crystallising liquids
- high-viscosity liquids, such as paints and varnishes
- aggressive liquids
- volatile liquids
- flammable liquids.

Most of the pumps are available with either mains-operated motors (CR, CRI and CRN) or electronically speed-controlled motors (CRE, CRIE and CRNE).

The pump types below are available as customized pumps.

Pump type	CR	CRI	CRN
1s, 1, 3, 5	•	•	•
10, 15, 20	•	•	•
32, 45, 64	•		•
95, 125, 155	•		•
185, 215, 255	•		•

Pumps for specific requirements

CR pumps can be customized to meet customer-specific requirements. This is due to the mix-and-match approach to customization, where the numerous pump features and options are to be regarded as modules that can be combined to create the ideal pump for the job at hand.

Motor options

CR motors are available in many different configurations to meet the requirements presented by the power supply, the pump environment and the pumped liquid itself.

- Power supply systems vary in terms of both frequency and voltage, and required protection methods.
- The environment may be explosive, very hot or very humid. Special conditions also apply at high altitudes.
- The pumped liquid may necessitate a special motor solution. High or low viscosities and high or low densities may require non-standard motor sizes. You may also need an explosion-proof variant.
- The installation site of the pump may require alternative positions of pump and motor parts, such as terminal box positions and vent screw positions.

Shaft seal options

Extreme liquids sometimes necessitate extreme measures.

- High temperatures damage seal faces unless precautions are taken.
- Concern for safety require special measures for aggressive, toxic or flammable liquids.
- Liquids can be harmful to shaft seals because they crystallise, harden or are extremely abrasive.

Pump options

The CR pump elements can handle the most demanding liquids and pressures, and can be adapted to suit many other requirements, such as the following:

- horizontal installation if height is a limitation
- poor inlet conditions requiring NPSH values to be adjusted to avoid cavitation
- very high pressures demanding special solutions
- special surface treatments or certificates.

Connection options

Your chosen pump elements can be fitted with exactly the connection options you need. All standards are covered, and special connection variants are available for maximum compactness, for example, high liquid pressures.

Features and benefits

Customized CR pumps have the following features and benefits:

Grundfos motor

Grundfos motors are remarkably silent and highly efficient.

3-phase pumps from 1.1 to 200 kW have premium efficiency IE3 motors as standard and optionally super premium efficiency IE4 and IE5. Grundfos motors are available with integrated frequency converter designed for speed-controlled operation. Speed-controlled operation can also be obtained by connecting a fixed-speed motor to an external Grundfos CUE or Danfoss frequency converter.

Shaft seal solutions

The specially designed cartridge seal increases reliability, ensures safe handling, and enables easy service and access.

The cartridge shaft seal comes in a wide choice of materials. It is available in single and double-seal arrangements, and magnetic-drive configurations.

Connections

The Grundfos CR pump can be connected to any system, and is available in four different material variants.

Material options

CRN, CRNE:	Stainless steel AISI 316
CRI, CRIE:	Stainless steel AISI 304
CR, CRE:	Stainless steel AISI 304/cast iron

Wide range of pump sizes

The CR pump comes in sixteen flow sizes and hundreds of pressure sizes, ensuring that you can always find exactly the right pump for the job.

High-performance hydraulics

Pump efficiency is maximized by the optimized hydraulics and carefully crafted production technology.

Dry-running protection

The patented Grundfos LiqTec system eliminates the risk of breakdowns caused by dry running. If there is no liquid in the pump, the LiqTec stops the pump immediately.



GR5357

ErP-compliant

The product is energy-optimized and complies with the ecodesign requirements for water pumps specified in the ErP Directive, Commission Regulation (EC) No 547/2012, effective as of January 1, 2013. From that day on, all pumps are classified and graduated in the Minimum Efficiency Index (MEI).

Minimum Efficiency Index

Minimum Efficiency Index (MEI) means the dimensionless scale unit for hydraulic pump efficiency at best efficiency point (BEP), part load (PL) and overload (OL). The Commission Regulation (EU) sets efficiency requirements to MEI over or equal to 0.10 as of January 1, 2013, and MEI over or equal to 0.40 as of January 1, 2015. An indicative benchmark for best-performing water pump available on the market as of January 1, 2013 is determined in the Commission Regulation.

- The benchmark for most efficient water pumps is MEI over or equal to 0.70.
- The efficiency of a pump with a trimmed impeller is usually lower than that of a pump with a full impeller diameter. The trimming of the impeller adapts the pump to a fixed duty point, leading to reduced energy consumption. The Minimum Efficiency Index (MEI) is based on the full impeller diameter.
- The operation of this water pump with variable duty points may be more efficient and economic when controlled, for example, by the use of a variable-speed drive that matches the pump duty to the system.
- Information on benchmark efficiency is available at <http://europump.eu/efficiencycharts>.

MEI values for CR pumps

Pump type	MEI
CR 1s-3	0.54
CR 1-3	> 0.70
CR 3-3	> 0.70
CR 5-3	0.57
CR 10-3	> 0.70
CR 15-3	> 0.70
CR 20-3	> 0.70
CR 32-3	> 0.70
CR 45-3	> 0.70
CR 64-3	> 0.70
CR 95-3	> 0.70
CR 125-3	> 0.70
CR 155-3	> 0.70
CR 185-3	> 0.70
CR 215-3	≥ 0.70
CR 255-3	≥ 0.70

Further documentation

This catalogue on customized CR pumps is a supplement to the data booklets listed below. For further information on our products and standard offerings, see the following data booklets available at the Grundfos Product Center.

Data booklet	Publication number	QR code
CR, CRI, CRN (50 Hz)	99301179	 QR99301179
CR, CRI, CRN (60 Hz)	99301180	 QR99301180
CRE, CRIE, CRNE (50/60 Hz)	98423696	 QR98423696
CR, CRN, CRNE high pressure	V7174003	 QRV7174003
Mechanical shaft seals for pumps	97506935	 QR97506935

2. Performance range

CR, CRI, CRN performance range

50 Hz

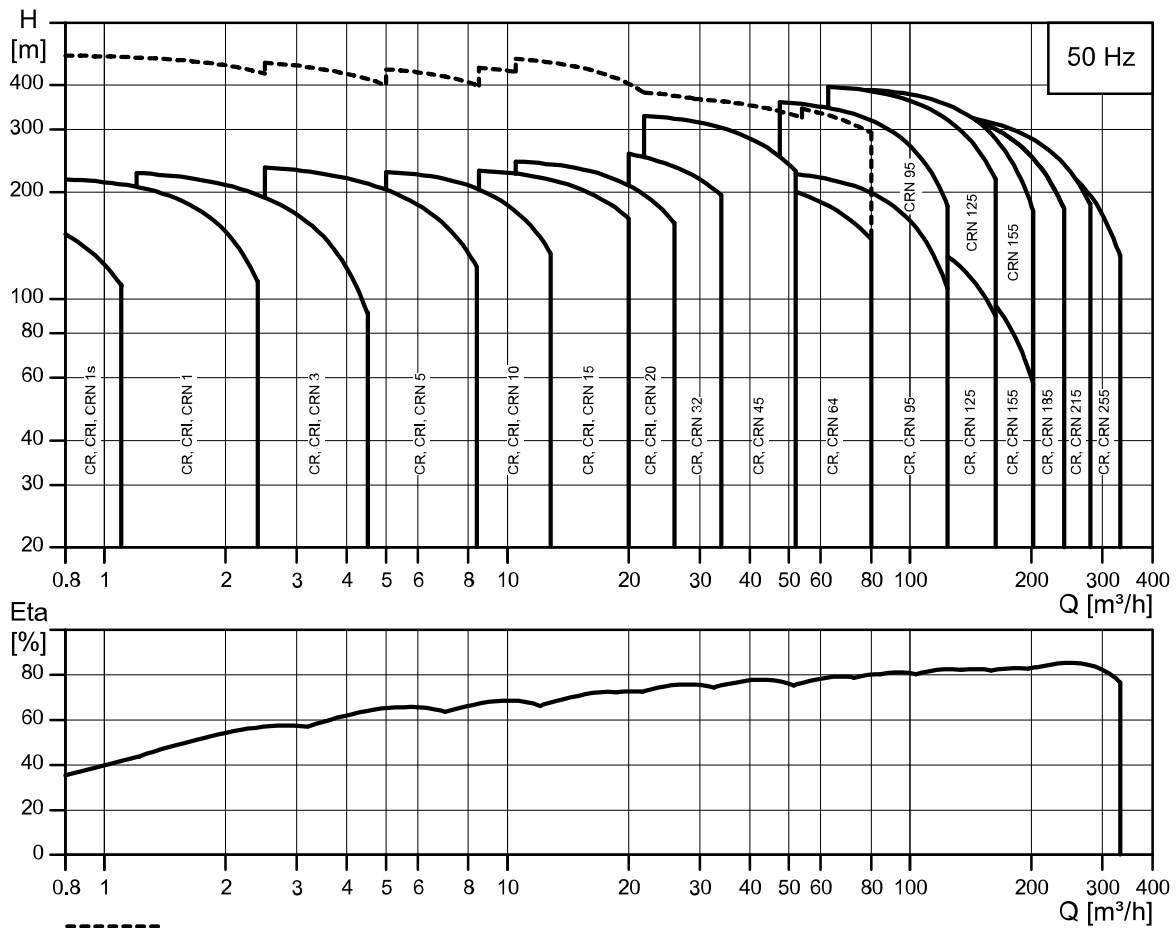

TM021192

Performance range for CR, CRI, CRN 50 Hz

----- High-pressure range

60 Hz

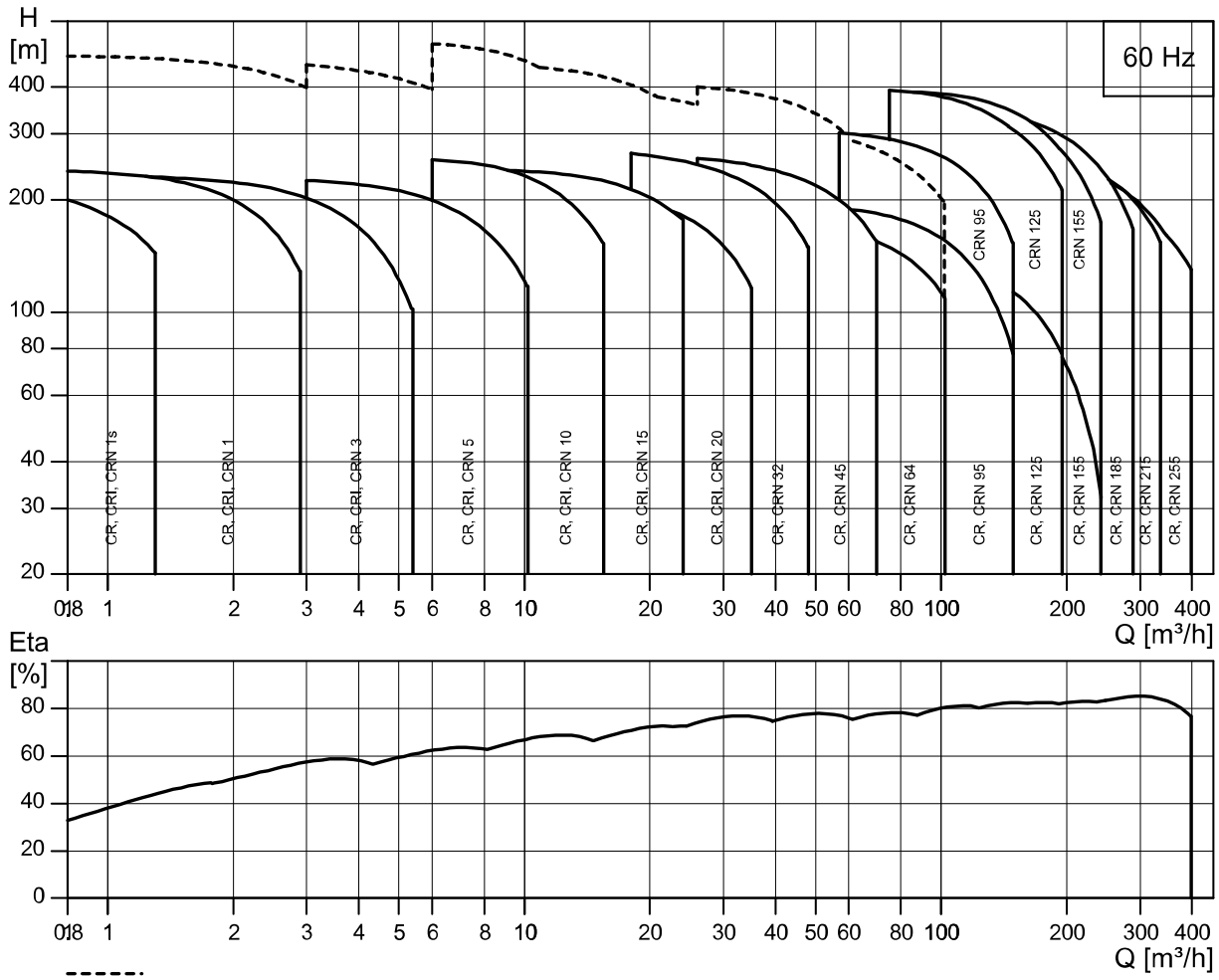

TM021530

Performance range for CR, CRI, CRN 60 Hz

----- High-pressure range

3. Identification

Type key

Example: CRE 32-3-2 A-F-A-E-HQQE

Code	Explanation
CR	Type range: CR, CRI, CRN
E	Pump with integrated frequency converter
32	Flow rate [m ³ /h]
3	Number of impellers
2	Number of reduced-diameter impellers
A	Code for pump version
F	Code for pipe connection
A	Code for materials
E	Code for rubber parts
	Code for shaft seal:
H	Shaft seal type designation
Q	Seal face material (rotating seal face)
Q	Seal face material (stationary seal face)
E	Secondary seal material (rubber parts)

Key to codes

Code	Description
Pump version	
A	Basic version
B	Oversize motor
C	CR compact
D	Pump with pressure intensifier
E	Pump with certificate
F	Pump for high temperatures (with air-cooled top)
G	E-pump without operating panel
H	Horizontal version
I	Different pressure rating
J	E-pump with a different maximum speed
K	Pump with low NPSH
L	Pump including Grundfos CUE and certificate
M	Magnetic drive
N	With sensor
O	Cleaned and dried
P	Undersize motor
Q	High-pressure pump with high-speed MGE motor
R	Belt-driven pump
S	High-pressure pump
T	Thrust-handling device
U	ATEX-approved pump
V	Cascade function
W	Deep-well pump with ejector
X	Special version
Y	Electropolished
Z	Pumps with bearing flange
Pipe connection	
A	Oval flange
B	NPT thread
CA	FlexiClamp
CX	TriClamp

Code	Description
F	DIN flange
FC	DIN 11853-2 flange (collar flange)
FE	EN 1092-1, type E
G	ANSI flange
J	JIS flange
N	Changed diameter of ports
P	PJE coupling (Victaulic type)
X	Special version
Materials	
A	Basic version
C	Carbon-free pump
D	Carbon-graphite-filled PTFE (bearings)/tungsten carbide
E	Carbon-free/tungsten carbide rotating bearing (only for Japan)
H	Flanges and base plate EN 1.4408
K	Bronze (bearings)/tungsten carbide
L	Motor stool, base plate and flanges EN 1.4408
M	Motor stool, base plate, coupling and flanges EN 1.4408 and coupling guards in cobber Bolts, nuts and spacing pipes EN 1.4401 or higher grade
N	Flanges EN 1.4408
P	PEEK neck ring
Q	Silicon carbide/silicon carbide bearing in pump and silicon carbide/silicon carbide seal faces in thrust-handling device
R	Silicon carbide/silicon carbide bearing
S	PTFE neck rings
T	Base plate EN 1.4408
U	Silicon carbide/silicon carbide bearing in pump and silicon carbide/tungsten carbide seal faces in thrust-handling device
W	Tungsten carbide/tungsten carbide
X	Special version
Rubber parts in pump	
E	EPDM
F	FXM (Fluoraz [®])
K	FFKM (Kalrez [®])
N	CR (Neoprene)
V	FKM (Viton [®])
Shaft seal type designation	
A	O-ring seal with fixed driver
H	Balanced cartridge seal with O-ring
O	Double seal, back-to-back
P	Double seal, tandem
X	Special version
Seal face material (rotating and stationary seal face)	
B	Carbon, synthetic resin-impregnated
U	Cemented tungsten carbide
Q	Silicon carbide
X	Other ceramics
Secondary seal material (rubber parts)	
E	EPDM
F	FXM (Fluoraz [®])
K	FFKM (Kalrez [®])
V	FKM (Viton [®])

4. Applications

High-pressure applications



TM078856

CR high-pressure pumps

Reference applications

- Filtration
- reverse osmosis
- cleaning and washing
- boiler feed.

Customized solutions

High-pressure applications often expose pumps to a variety of extreme conditions, such as high inlet pressure, high operating pressure, frequent starts/stops and pressure pulsing. Overload of the pump may cause increased wear of pump parts, such as motor bearings and shaft seal, and thus reduce the pump life.

To avoid unexpected breakdowns, we offer customized solutions designed to meet your needs.

High-pressure handling

We offer high-pressure pumps specially designed to cope with pressures up to 50 bar at maximum 120 °C.

When necessary, CR high-pressure pumps are fitted with a bearing flange. A bearing flange is an additional flange with an oversize ball bearing designed to absorb axial forces in both directions.

CR high-pressure pumps come in two variants: as a single-pump solution or as a two-pump solution. The single-pump solution is used for flow rates up to 5 m³/h, while the two-pump solution is for flow rates above 5 m³/h.

Single-pump solutions

Our single-pump solutions include the pump types CRNE 1 HS and CRNE 3 HS.

CRNE HS pumps are fitted with a high-speed motor with integrated frequency converter.

To minimise the pressure on the shaft seal, the direction of rotation is the opposite of the direction of standard pumps, and the chamber stack is turned upside down. Consequently, the pumped liquid flows in the opposite direction.

Two-pump solutions

We offer two-pump solutions for the following pumps: CRN 3, 5, 10, 15, 20, 32, 45, 64 SF

The solution consists of two pumps in series. The first pump is a standard pump for feeding. The second pump is either a high-pressure pump (SF) specially designed for high pressure, or a standard pump.

To minimise the pressure on the shaft seal, the direction of rotation on CR SF pumps is the opposite of that of standard pumps, and the chamber stack is turned upside down. Consequently, the pumped liquid flows in the opposite direction.

Further documentation

The following data booklet is available at the Grundfos Product Center.

Data booklet	Link and publication number
CR, CRN High pressure	http://net.grundfos.com/qr/i/V7174003

Supplementary Grundfos pumps

For pressures above 50 bar, we recommend Grundfos BM modules or Grundfos BME, BMET pumps.

Further information about BM modules and BME, BMET pumps is available at the Grundfos Product Center.

Related information

[Special installation requirements](#)

[PN 25 and PN 40 pumps](#)

[Bearing flange](#)

[10. CRE pump solutions](#)

[16. Grundfos Product Center](#)

Hot-water applications

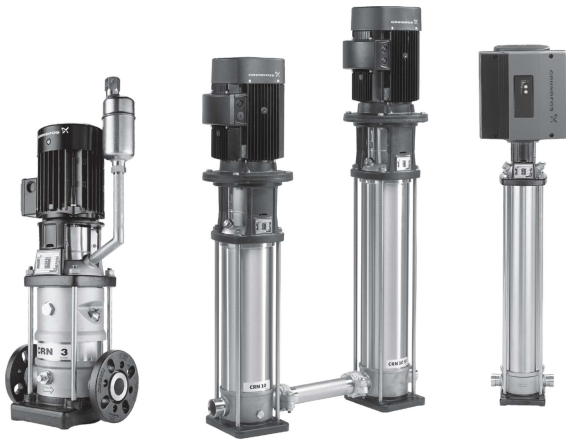

TM078857

CR pumps for hot-water applications

Reference applications

- Boiler feeding
- applications involving poor inlet conditions
- cleaning and washing applications
- high-temperature applications.

Customized solutions

Hot-water applications often expose pumps to a variety of extreme conditions, such as high temperatures, long operating hours, frequent starts/stops, pressure pulsing, poor inlet conditions and high inlet pressure. Such conditions may result in cavitation and/or cause increased wear of pump parts, for instance, motor bearings and shaft seal, and thus reduce the pump life.

To avoid breakdowns, we offer customized solutions designed to meet your needs. We provide solutions for applications involving special conditions, for example:

- steady steam production
- poor inlet conditions
- high temperature.

Steady steam production

To ensure steady steam production and constant water level in the boiler tank, we recommend speed-controlled pumps that also provide the following advantages:

- Steady and continuous flow of water increases efficiency of the boiler.
- The reaction to changes in the steam consumption is faster compared to the on/off pump control.
- The water level in the boiler feed tank is kept stable ensuring higher steam quality and less humidity in the steam.
- The installation and maintenance costs are lower compared to systems with on/off controlled pumps and valves, as well as systems with level control and modulating feed valves.
- No bypass pipe is needed.

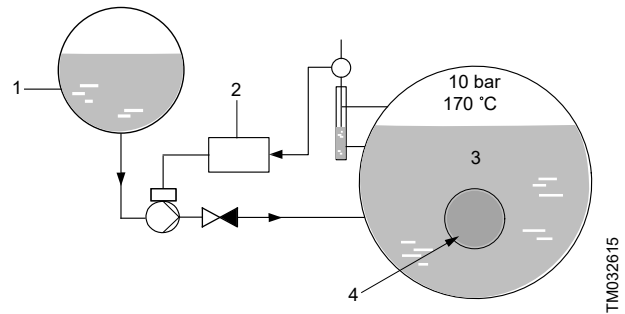

TM032615

Boiler-feed application with speed-controlled pump

Pos.	Description
1	Condensate
2	Controller
3	Boiler
4	Burner

Applications involving poor inlet conditions

Cavitation is often a problem in applications where pumps have to cope with the combination of high liquid temperatures, poor inlet pressure or a high flow rate.

Low-NPSH pumps eliminate the risk of cavitation and ensure stable and reliable operation.

The CR low-NPSH pump is a pump with a special first-stage design that reduces the NPSH value and prevents erosion and destruction of the pump, pipes and valves.

For further information about NPSH and the calculation of NPSH-values, see the relevant data booklets available at the Grundfos Product Center.

High-temperature applications

The pumping of hot liquids is demanding for pump parts, such as the shaft seal and rubber parts.

To ensure reliable and stable production, we offer CR pumps with an air-cooled top.

A CR pump with an air-cooled top has a standard mechanical shaft seal handling liquid temperatures up to 180 °C at 25 bar without external cooling. At the same time, the pump delivers high pressure. As the name implies, the pump is fitted with a special air-cooled shaft seal chamber generating the same insulation effects as that of a vacuum flask.

Related information

[Further documentation](#)

[Special installation requirements](#)

[Oversize motors](#)

[Air-cooled top](#)

[CR low NPSH](#)

[Bearing flange](#)

[10. CRE pump solutions](#)

[16. Grundfos Product Center](#)

Temperature control applications



CRE, CRIE, CRNE pumps with sensor

Reference applications

Cooling systems:

- Electronic data processing
- laser equipment
- medical equipment
- industrial cooling and freezing processes.

Temperature-control systems:

- Casting and moulding tools
- oil processing.

Customized solutions

To ensure safe and reliable operation in applications involving temperature control, we offer customized solutions designed to meet your needs.

We provide solutions for applications involving pumping of the following media:

- liquids at temperatures down to $-40\text{ }^{\circ}\text{C}$
- high-temperature liquids
- high-viscous liquids, and similar.

Pumping of liquids down to $-40\text{ }^{\circ}\text{C}$

In applications where liquids are pumped at temperatures down to $-40\text{ }^{\circ}\text{C}$, it is crucial for successful production that pump parts are of the right material and dimension.

At such low temperatures, wrong materials and dimensions may cause deformation due to thermal expansion, and eventually lead to stoppage of operation.

For low-temperature liquids below $-20\text{ }^{\circ}\text{C}$, we recommend CRN pumps.

Pumping of high-temperature liquids

The pumping of hot liquids is demanding for pump parts, such as shaft seals and rubber parts. Examples of such media are:

- water-based liquids up to $180\text{ }^{\circ}\text{C}$ at PN 25
- thermal oils up to $240\text{ }^{\circ}\text{C}$ at PN 16.

To ensure reliable and stable production, we offer CR pumps with an air-cooled top and special rubber parts.

A CR pump with an air-cooled top is a pump which can handle high temperatures and deliver high pressure. The pump is fitted with a special air-cooled shaft seal chamber generating the same insulation effects as that of a vacuum flask.

Pumping of high-viscous liquids

In applications where high-viscous liquids are pumped, precautions must be taken to ensure that the motor of the pump is not overloaded, and that the pump performance is not reduced too much.

The viscosity of a pumped liquid depends strongly on the liquid temperature.

To ensure stable and reliable operation, we offer CR pumps with oversize motors.

Related information

[Special installation requirements](#)

[ATEX-approved pumps](#)

[Oversize motors](#)

[Air-cooled top](#)

[Pump rubber parts](#)

[10. CRE pump solutions](#)

[16. Grundfos Product Center](#)

TM027397

Aggressive/hazardous liquids



CR pumps for aggressive/hazardous liquids

Reference applications

- Chemical industry
- pharmaceutical industry
- refineries
- petrochemical industry
- distilling plants
- paint industry
- mining.

Customized solutions

In industries where pumping of dangerous and aggressive liquids is an integrated part of the daily production, safety is top priority. Leaking pumps pose a danger to the environment.

To prevent breakdowns, we offer customized solutions designed to meet your needs.

We provide solutions for the following media:

- aggressive and abrasive liquids
- toxic and hazardous liquids
- flammable liquids
- odorous liquids.

To ensure safe handling of the above media, we offer the following:

- pumps with tandem seal arrangement and flushing
- pumps with back-to-back seal arrangement and pressure intensifier
- pumps with magnetic drive (MAGdrive)
- pumps with ATEX approval.

Pumps with tandem seal arrangement

Pumps with tandem seal arrangements connected to a flushing device are used for crystallising, hardening or sticky liquids.

If the primary seal leaks, the leaking liquid is flushed away by a flushing liquid.

Pumps with back-to-back seal arrangement

We recommend pumps with back-to-back seal arrangements for toxic, aggressive or flammable liquids.

Pumps with back-to-back seal arrangements are connected to systems that provide a higher pressure than the maximum pump pressure, preventing leakage from the pump to the atmosphere.

MAGdrive pumps

We recommend pumps with magnetic drive (MAGdrive) for toxic and hazardous liquids.

The MAGdrive pump is a hermetically sealed pump. In the MAGdrive pump, the power from the motor is transmitted to the pump shaft by magnetic force instead of a traditional coupling.

The motor shaft and the pump shaft are hermetically separated from each other.

ATEX-approved pumps

We recommend ATEX-approved pumps for potentially explosive atmospheres. Explosive atmospheres consist of air and combustible matter such as gas, vapour, mist or dust in which the explosion spreads after ignition.

Electropolished pumps

We recommend electropolished pumps for applications with strict requirements concerning corrosion and cleanliness.

We offer electropolished pumps in all CRN pump sizes.

Related information

[Special installation requirements](#)

[ATEX-approved pumps](#)

[Back-to-back seal arrangement](#)

[Tandem-seal arrangement](#)

[Magnetic-drive pump \(MAGdrive\)](#)

[10. CRE pump solutions](#)

[16. Grundfos Product Center](#)

Hygienic applications



TM078859

CR pumps for hygienic applications

CR pumps are not designed for the pumping of hygienic and sterile liquids, but their construction and the choice of materials make them an ideal solution for secondary processes in hygienic applications.

Reference applications

- Pharmaceutical industry
- biotechnological industry
- electronics industry
- food and beverage industry
- process industry.

Customized solutions

We provide solutions for applications involving special requirements regarding hygienic design, materials, surface quality and cleanability.

Hygienic design

The surface quality of pump parts is of utmost importance both for corrosion resistance and microbial adhesion and growth.

To meet the strict hygienic requirements to material and surface quality in secondary hygienic processes, we offer electropolished stainless steel CRN pumps with the following surface quality:

Pump type	Cast stainless steel	Stainless-steel parts (not cast)	Surface quality
CRN 1s, 1, 3, 5	•	•	Ra ≤ 0.8 μm
CRN 10, 15, 20	•	•	Ra ≤ 0.8 μm
CRN 32, 45, 64	•	•	Ra ≤ 8.0 μm
CRN 95, 125, 155	•	•	Ra ≤ 8.0 μm
CRN 185, 215, 255	•	•	Ra ≤ 8.0 μm

- Available

Note that CRN pumps are not sanitary pumps regardless of the surface quality.

Furthermore, we offer a wide variety of connections, such as TriClamp connections, specially designed for pharmaceutical, food and beverage industries. For further information about TriClamp connections, see the section about connections.

We offer the following solutions:

- cleaned and dried pumps
- mechanically or electropolished pumps.

Electropolished pumps have a higher corrosion resistance than non-polished pumps.

Cleanability

For secondary hygienic applications, for example, non-food contact applications, we recommend CRN and CRE pumps that have all pump parts in stainless steel. As the surface and properties of the metal is not affected by cleaning agents, stainless steel is the ideal solution.

ATEX-approved pumps

We recommend ATEX-approved pumps for potentially explosive atmospheres. Explosive atmospheres consist of air and combustible matter such as gas, vapour, mist or dust in which the explosion spreads after ignition.

Related information

[Special installation requirements](#)

[ATEX-approved pumps](#)

[CRN all-stainless steel pumps](#)

[Surface treatment](#)

[TriClamp connection](#)

[10. CRE pump solutions](#)

[16. Grundfos Product Center](#)

Special installation requirements



CR pumps for special installations

Reference applications

- Places with limited access and space
- ships
- mobile applications
- fire protection
- earthquake-prone areas
- applications in remote areas.

Customized solutions

Due to safety, location and arrangement requirements, some installations require pumps with different design than that of traditional vertical pumps.

To meet special installation requirements, we offer customized solutions designed to meet your needs.

We provide solutions for the following pump types:

- horizontally mounted pumps
- belt-driven pumps
- pumps with alternative mounting.

Horizontally mounted pumps

We recommend horizontally mounted pumps in the following cases:

- installations with limited access and space, such as cabinets and compact systems
- installations with limited height
- earthquake-prone areas
- mobile systems, such as ships and vehicles.

Horizontally mounted pumps lower the centre of gravity and thus minimise swings during an earthquake.

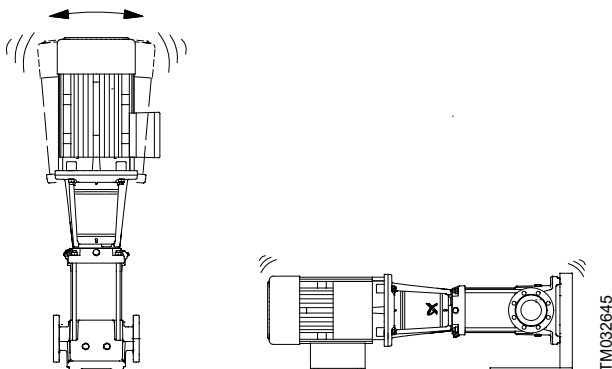

Vibrations of pumps in earthquake-prone areas

Horizontal mounting requires special mounting plates.

Belt-driven pumps

Belt-driven pumps are often selected in the following cases:

- non-electrically driven applications, such as air-, solar-, wind-, diesel- and pneumatically driven applications
- installations requiring an alternative supply, such as firefighting systems and emergency pumps.

The construction of belt-driven pumps is similar to that of electrically driven pumps, but belt-driven pumps have a pulley and belt connected to a combustion motor or other device.

Alternative mounting for limited access and space

For installations with limited access and space, we offer pumps with alternative mounting of pump parts, such as terminal box and vent screw.

Certificates, approvals and reports

We offer customized pumps with a wide variety of certificates and approvals, for example:

- Inspection certificate 3.1C
 - Lloyds Register of Shipping (LRS)
 - Det Norske Veritas (DNV)
- ATEX, VIK and UL approvals
- Duty-point verification report
- Vibration test report.

Related information

[CRN all-stainless steel pumps](#)

[Horizontal in-line pumps](#)

[Belt-driven pumps](#)

[CR pumps with certificates](#)

[10. CRE pump solutions](#)

[16. Grundfos Product Center](#)

TM060754

TM032645

Special applications



CRNE and CRN pumps

Reference applications

- Off-shore and maritime applications
- cooling applications
- deep-well pumping systems
- pumps operating under special conditions.

Customized solutions

We offer customized solutions for a number of applications not mentioned on the previous pages, such as the following:

- off-shore and maritime applications
- pumping of liquids down to $-40\text{ }^{\circ}\text{C}$
- deep-well pumping in small water supply systems
- special conditions
- special requirements as to approvals, voltage and frequency.

To ensure stable and reliable operation, we offer customized solutions designed to meet your needs.

Off-shore and maritime applications

In off-shore and maritime applications, pumps must meet strict requirements regarding reliability in connection with, for instance, cooling, firefighting, cleaning and desalination systems. Pumps are often installed in corrosive environment.

We offer customized pumps with a wide variety of 3.1C inspection certificates, such as Lloyds Register of Shipping (LRS) and Det Norske Veritas (DNV).

Furthermore, we offer customized pumps with a wide variety of materials, connections and enclosure classes.

CRE pumps that have all pump parts in titanium. As the corrosion resistance of CRE pumps is not affected by seawater, titanium is the ideal solution.

Pumping of liquids down to $-40\text{ }^{\circ}\text{C}$

In applications with liquid temperatures down to $-40\text{ }^{\circ}\text{C}$, the material of shaft-seal faces, the dimensions of the neck ring and other factors must meet high requirements. At such low temperatures, choosing the wrong material or dimension may cause deformation in the pipes due to thermal expansion, and eventually lead to stoppage of operation.

For liquids below $-20\text{ }^{\circ}\text{C}$, we recommend CRN pumps.

Deep-well pumping in small water supply systems

Water is pumped from depths down to 90 metres. The system consists of a dry-mounted CR pump connected to a submerged ejector.

Pumps operating under special conditions

- Installations at high altitudes:
 - over 3,500 metres if fitted with Grundfos MG IE3 motors
 - over 2,750 metres if fitted with Innomatics IE3 motors
 - over 1,000 metres if fitted with Grundfos MGE motors.
- Applications with low, high or fluctuating ambient temperatures
- Pumping of high-viscous or high-density liquids.

In such cases, the motor may be overloaded and an oversize motor may be required.

Special requirements

We offer customized pumps meeting special requirements regarding approvals, voltage and frequency.

Supplementary Grundfos pumps

If the suction head exceeds 90 metres, we recommend Grundfos SP and SQ submersible pumps.

Further information about SP and SQ pumps can be found at the Grundfos Product Center.

Related information

[Special installation requirements](#)

[Oversize motors](#)

[Pumping of liquids of temperature as low as \$-40\text{ }^{\circ}\text{C}\$](#)

[CR, CRI deep-well pumps](#)

[CR pumps with certificates](#)

[10. CRE pump solutions](#)

[16. Grundfos Product Center](#)

Intended use in the United Kingdom

E-pumps fitted with motors that include Bluetooth or Ethernet connection, a radio module or a CIM 90, CIM 280, CIM 290, CIM 550, MI 301 interface module are not intended for use in any home appliance, home automation, home control system or consumer product in the UK.

5. Accessories

ATEX-approved dry-running protection

For environments of group II, category 2G, always use dry-running protection.

The link between ATEX groups, categories and zones is explained in the 1999/92/EC directive. Note that this is a minimum directive. Some EEC countries may therefore have stricter local rules. The user or installer is always responsible for checking if the group and category of the pump correspond to the zone classification of the installation site.

The dry-running protection with ATEX approval mentioned below is offered by Grundfos.

Components

Designation	Ex-marking	Connection	[°C]	Product number
Flow sensor	II 2G Ex ib IIC T6	G 1/2 AISI 316Ti	85	96607921
		G 1/2 AISI 316Ti	120	96607922
Amplifier for flow sensor	- II (1) GD [Ex ia] IIC		[V]	-
			230	96607923

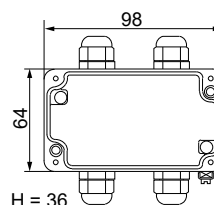
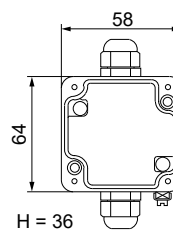

TM079116

ATEX-approved extension box (H: height)

The extension box is designed for connection of intrinsically safe or non-intrinsically safe circuits in explosion-hazardous areas of category 2 (zone 1 and 21).

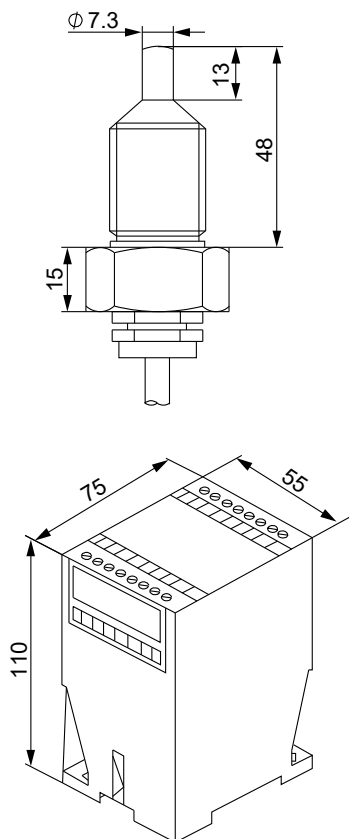

TM051169

ATEX-approved flow sensor and amplifier

Venting valve with connecting pipe

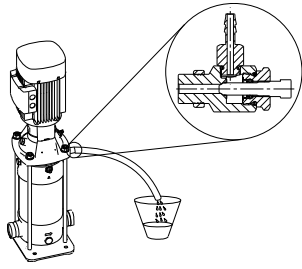

Venting valve with connecting pipe

The connecting pipe of this special venting valve allows the operator to de-aerate the pump into a closed container. This accessory is ideal when pumping aggressive or hazardous liquids.

Designation	Connection	Type	Product number
Venting valve with connecting pipe	G 1/2	EPDM	97773787
		FKM	97775104
		FFKM	97775105
		FXM	97775106

Dosing pump system for barrier fluid

The dosing pump system is used for supplying pressurised barrier liquid to a CR pump with a back-to-back seal arrangement.

Designation	Product number
Dosing pump system for barrier fluid, 50 Hz	96449957
Dosing pump system for barrier fluid, 60 Hz	96462388

Related information

[Back-to-back seal arrangement](#)

[CR pump with dosing pump in back-to-back seal arrangement](#)

Flushing-liquid tank for pumps with tandem seal arrangements

Stainless steel tank for flushing-liquid systems.

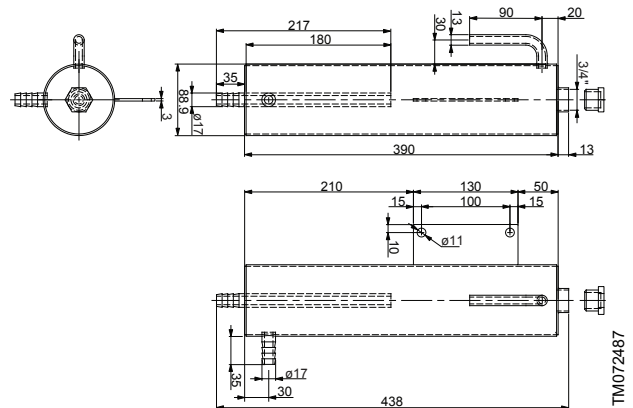

Tank dimensions

Designation	Product number
Flushing-liquid tank excl. fittings and hose	96609459

Related information

[Tandem-seal arrangement](#)

6. Motor

The Grundfos standard range of motors meets a wide variety of application demands. For special applications or operating conditions, we offer various customized solutions:

- wide range of motor approvals
- motors with special voltage
- motors with an anti-condensation heater
- motors with Harting® 10-pin multiplug connection
- motors with built-in PTC sensor
- motors with built-in thermal switch
- undersize and oversize motors
- motors with alternative enclosure class
- motors with bearings suitable for high-temperature operating conditions (bearings are packed with grease suitable for high temperatures)
- IE4 motors
- IE5 motors with permanent magnet rotor.

VIK-approved motors

We recommend VIK-approved motors for industrial climates where aggressive gasses and/or aggressive vapours are likely to occur.

The VIK standard applies to three-phase mains-operated motors and three-phase motors connected to a frequency converter.

We offer VIK-approved motors from 0.37 to 200 kW in accordance with the requirements of the German industrial standard, Verband der Industriellen Energie- und Kraftwirtschaft. To comply with the standard, VIK-approved motors must meet the following requirements:

- They must be categorised as Group II, Category 2, version EEx e or EEx d, temperature class T3 in the ATEX directive. If in doubt, consult the above standard or contact Grundfos.
- They must have enclosure class IP55 as a minimum.
- They must be protected against sucking. This phenomenon may occur when the pressure inside the motor is lower than the atmospheric pressure. In such cases, moisture is sucked into the motor through, for example, bearing housings.

For further information about the VIK-standard, see www.vik.de or contact Grundfos.

Tropicalised motors

A tropicalised motor does not contain paper, wood or similar materials containing wood pulp.

Grundfos defines a tropicalised motor as a motor which fulfils the climate group World-Wide in DIN/IEC 721-2-1 and has the following characteristics:

- enamel-covered windings
- double winding impregnation
- double winding insulation
- FPM V-ring
- terminal board made of polyester
- liquid sealing between frame and flange/end shield
- all outside screws made of stainless steel
- 30 µm paint layer on aluminium stator housings
- 120 µm paint layer on cast-iron stator housings
- heating element.

cURus-, UR- and CSA-approved motors

We offer mains-operated motors with the following approvals:

Approval	Motor power - P2 [kW]
cURus	0.37 - 22
UR	30-200
CSA	30-200

Energy

We offer mains-operated motors that comply with the following energy standards:

- CEL
- EISA 2007
- KEMCO
- INMETRO
- NOM-016-ENER
- cURus ENERGY.

Other motor approvals

We offer a wide range of motor approvals, such as the following:

- CCC
- C-tick
- GOST
- BA
- TSU
- METI/JQA
- CB
- TSENK.

ATEX-approved pumps



TM016193

ATEX-approved pumps are for use in potentially explosive atmospheres. Explosive atmospheres consist of air and combustible matter such as gas, vapour, mist or dust in which the explosion spreads after ignition.

We offer explosion-proof motors in accordance with the EU directive 2014/34/EU, the so-called ATEX directive. The ATEX-approved pumps can be used in areas (zones) classified according to the directive 1999/92/EC. If in doubt, consult the above-mentioned directives or contact Grundfos.

ATEX-approved pumps are supplied with serial number, special installation and operating instructions, and a nameplate showing the ATEX classification. The nameplate includes an X to indicate that the product is subject to special conditions for safe use.

An ATEX certificate is available on request.

Scope of ATEX categories

Group I	
	Category M2
Underground installations in mines liable to be endangered by explosive gasses or combustible dust	Pumps made of materials that do not create sparks and thus not constitute any danger of explosion
CR pumps available	CR, CRI, CRN
Motors available	None ¹⁾

¹⁾ Air-driven or hydraulically driven motors are not available from Grundfos.

Group II		
	Category 2	
Installation areas liable to be endangered by explosive atmospheres	Pumps intended for use in areas in which explosive atmospheres are likely to occur	
	G (gas)	D (dust)
1999/92/EC ²⁾	Zone 1	Zone 21
CR pumps available	CR, CRI, CRN ³⁾	CR, CRI, CRN
Motors available	II 2G Ex db IIB T4 Gb II 2G Ex db IIC T4 Gb II 2G Ex db eb IIB T4 Gb II 2G Ex db eb IIC T4 Gb	

²⁾ The link between groups, categories and zones is explained in the 1999/92/EC directive. Some EEC countries may have stricter local rules. The user or installer is always responsible for checking if the group and category of the pump correspond to the zone classification of the installation site.

³⁾ For group II, category 2 G (zone 1), the pump must be protected against dry running. Use one of the following methods:

- An ATEX-approved dry-running protection.
 - Always use this protection on pumps with MAGdrive or pumps with a single mechanical shaft seal.
- Pumps with double seal system.
 - Back-to-back:
 - The system for pressurising the system must be ATEX-approved.
 - Tandem:
 - Make sure that the flow rate of flushing liquid is always sufficient, and the elevated tank never runs dry of flushing liquid.

Group II		
	Category 3	
Installation areas liable to be endangered by explosive atmospheres	Pumps intended for use in areas in which explosive atmosphere only rarely occur	
	G (gas)	D (dust)
1999/92/EC ²⁾	Zone 2	Zone 22
Pumps available	CR, CRI, CRN	CR, CRI, CRN
Motors available	II 2G Ex db IIB T4 Gb II 2G Ex db IIC T4 Gb II 2G Ex db eb IIB T4 Gb II 2G Ex db eb IIC T4 Gb	

We offer the following ATEX-approved motors:

Motor [kW]	Version			
	II 2G Ex db IIB T4 Gb	II 2G Ex db IIC T4 Gb	II 2G Ex db eb IIB T4 Gb	II 2G Ex db eb IIC T4 Gb
0.37 - 200	•	•	•	•

All explosion-proof motors have PTC sensors.

Related information

[Motors with PTC sensors](#)

Certificate for an ATEX-approved pump

Grundfos offers certificate for ATEX-approved pumps. The certificate has to be confirmed for every order. If a certificate is needed, order it when ordering the pump.

Report
ATEX approved pump

General info			
Customer name			
Customer order no.			
Customer TAG no.			
GRUNDFOS order no.			
Pump type			
Serial number	Model		
Pump part No.	Serial No.		
Motor part No.	Serial No.		
ATEX Approval of pump	Technical File No.		

GRUNDFOS hereby confirms that the pump mentioned above is manufactured according to the ATEX directive. This means the pump is conformity with the ATEX 2014/34/EU ANNEX VIII directive as mentioned in the "ATEX Supplement to installation and operating instructions" supplied with the pump.

GRUNDFOS _____

Date:

Signature:

Name:

Dept.:

be think innovate
Part no. 96512240/PMU/000/1281066

TM034166

Special voltage

We offer pumps with following voltages:

Frequency	Voltage
Mains-operated motor	
50 Hz	3 x 220-240 Δ/380-415 YV
	3 x 200-220/346-380 V
	3 x 380-415 ΔV
	3 x 380-415 Δ/660-690 YV
	3 x 200-230/346-400 V
	3 x 208-230/460 V
60 Hz	3 x 220-255 Δ/380-440 YV
	3 x 220-277 Δ/380-480 YV
	3 x 220-277 Δ/380-480 YV
	3 x 380-440 ΔV
	3 x 380-480 ΔV
	3 x 380-480 Δ/660-690 YV
Motor with integrated frequency converter	
50/60 Hz	1 x 200-240 V
	3 x 380-500 V (0.37 - 2.2 kW)
	3 x 380-480 V (3-26 kW)

Note that other voltages are available on request.

Order the certificate via the product number.

Description	Product number
Certificate for ATEX-approved pump	96512240

Motor with multiplug connection



Mains-operated motor with Harting® 10-pin multiplug

Mains-operated motors fitted with a Harting® 10-pin multiplug connection, HAN 10 ES, enable easy connection to the mains.

Note that for Grundfos motors with integrated frequency converter, we offer the solutions shown in the section about plug-and-pump solutions for CRE pumps.

The purpose of a multiplug connection is to make the electrical installation and service of the pump easier. The multiplug functions as a plug-and-pump device.

The drawings below show the position of the multiplug on the mains-operated motor.

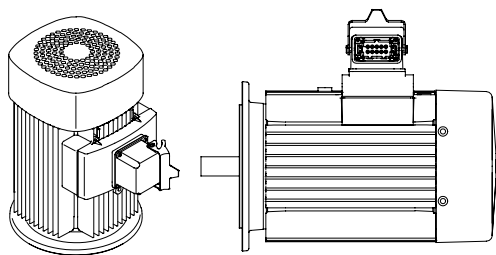

Motor with multiplug connection

The multiplug connection is available for the following motor sizes:

Motor power P2 [kW]	Voltage [V], starting method
0.37 - 7.5	3 x 220-240 Δ/380-415 YV
0.37 - 7.5	3 x 380-415 ΔV

Logo for multiplug



Dimensions

All dimensions are in millimetres.

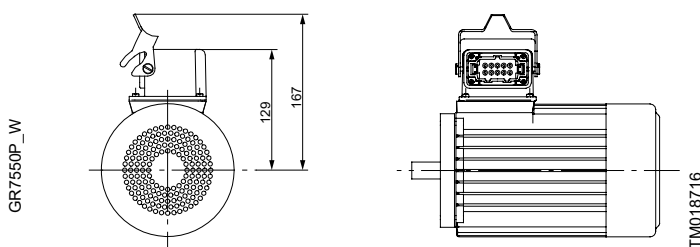

Dimensions, 0.37 - 1.1 kW

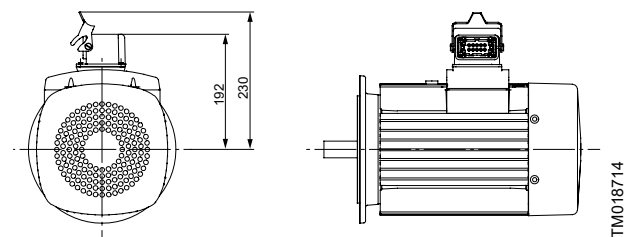

Dimensions, 1.5 - 7.5 kW

Plug connections

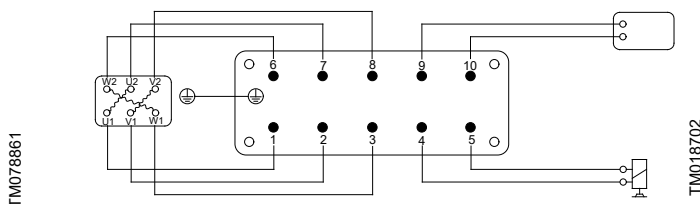

Plug connection from motor

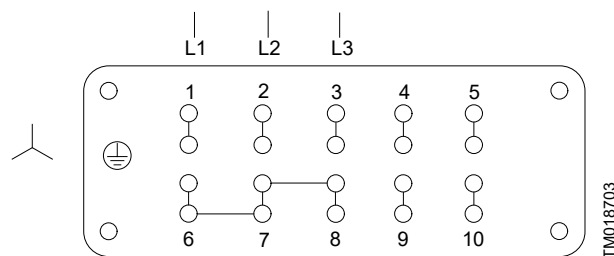

Plug connection for star connection

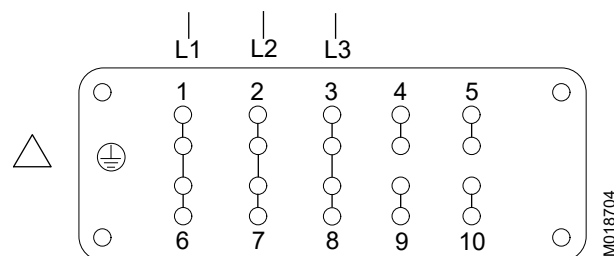

Plug connection for delta connection

Note that fishplates for connections are located in the plug.

Motor with anti-condensation heater



TM032440

Mains-operated MG motor with an anti-condensation heater

In applications where condensation in the motor may occur, we recommend that you install a motor with an anti-condensation heater on the stator coil ends. The heater keeps the motor temperature higher than the ambient temperature and prevents condensation.

Note that an anti-condensation heater is standard on all MGE motors and can be activated remotely.

High humidity may cause condensation in the motor. Slow condensation occurs as a result of a decreasing ambient temperature, while rapid condensation occurs as a result of shock cooling caused by direct sunlight followed by rain. We recommend that you always use motors with an anti-condensation heater in areas with ambient temperatures below 0 °C.

Note that rapid condensation is not to be confused with the phenomenon that occurs when the pressure inside the motor is lower than the atmospheric pressure. In such cases, moisture is sucked from the atmosphere into the motor through, for example, bearings and housings.

In applications with continuously high humidity levels above 85 %, the drain holes in the drive-end flange must be open. This changes the enclosure class to IP44. If IP55 protection is required due to operation in dusty environments, we recommend that you install a motor with an anti-condensation heater.

The figure below shows a typical circuit of a three-phase motor with an anti-condensation heater.

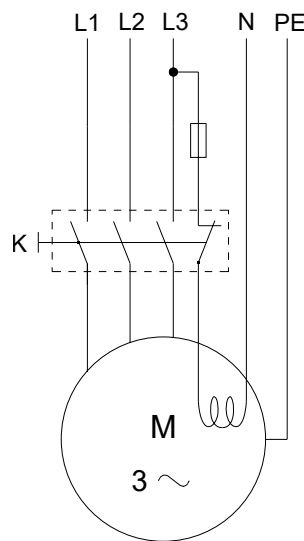

TM034058

Three-phase motor with an anti-condensation heater

Key

Symbol	Designation
K	Contactar
M	Motor

Connect the anti-condensation heater to the supply voltage so that it is on when the motor is switched off. Motors from 0.37 to 200 kW are available with an anti-condensation heater.

Motor size, 50/60 Hz [kW]		Power of heating unit [W]		
2-pole	4-pole	1 x 24 V	1 x 115 V	1 x 190-250 V
0.37 - 1.1	0.25 - 0.75			23
1.5 - 3.0	1.1 - 3.0	38		31
4.0 - 5.5	4.0		-	38
7.5 - 22	5.5 - 15 ⁴⁾	38		38
30-37	18.5 ⁴⁾		55	55
45-55	-	-	92	92
75	-		109	109

4) 15 and 18.5 kW 4-pole sizes are oversize motors in the CR pump range.

Motors with PTC sensors



TM027038

PTC sensor incorporated in winding

Built-in PTC sensors (thermistors) protect the motor against rapid as well as steady overload.

We offer motors with temperature-controlled PTC sensors in the motor windings.

Three-phase mains-operated motors from 3 kW and up have PTC sensors as standard.

Note that temperature-controlled PTC sensors must be connected to an external tripping or LiqTec unit connected to the control circuit. For further information about LiqTec, see section about LiqTec.

PTC sensors offer protection against steady and rapid overload. PTO sensors offer protection against steady overload.

PTC sensors comply with DIN 44 082. Maximum voltage (U_{max}) at the terminals is 2.5 VDC. All tripping units available for DIN 44 082 PTC sensors meet this requirement.

The figure below shows a typical circuit of a three-phase motor with PTC sensors.

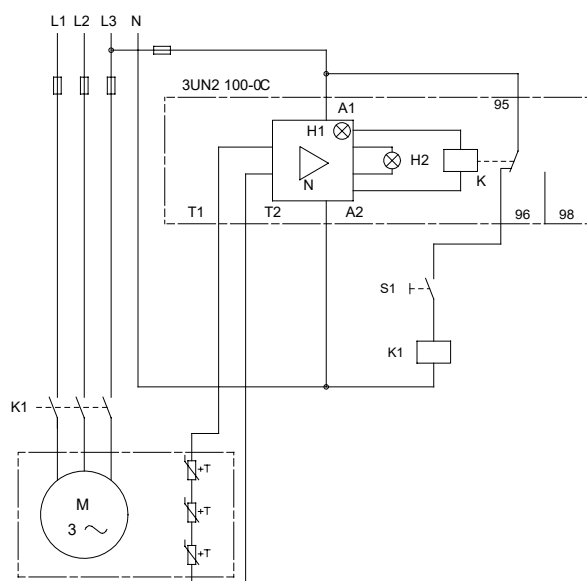

TM003965

Three-phase motor with PTC sensors

Key

Symbol	Designation
S1	On/off switch
K1	Contactors
+T	PTC sensor (thermistor) in motor
M	Motor
3UN2 100-0 C	Tripping unit with automatic reset
N	Amplifier
K	Output relay
H1	LED Ready
H2	LED Tripped
A1, A2	Connection for control voltage
T1, T2	Connection for PTC sensor loop

Related information

[LiqTec](#)

Motors with thermal switches



TM027042

Thermal switch incorporated in winding

Built-in thermal switches protect the motor against rapid as well as steady overload.

We offer three-phase mains-operated motors from 0.37 to 11 kW with built-in thermal switches.

Note that thermal switches must be connected to an external control circuit to protect the motor against steady overload. The thermal switches require no tripping unit.

Protection is according to IEC 60034-11: TP 211 (steady and rapid overload). As protection against seizure, connect the motor to a motor-protective circuit breaker.

Thermal switches tolerate the following maximum loads:

U_{max}	250 VAC
I_N	1.5 A
I_{max}	5.0 A (locked-rotor and breaking current)

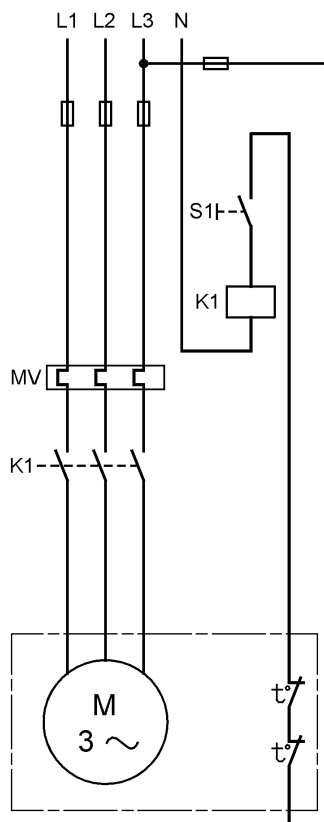

TM003964

Typical circuit of a three-phase motor with built-in bimetallic thermal switches

Key

Symbol	Designation
S1	On/off switch
K1	Contactor
t°	Thermal switch in motor
M	Motor
MV	Motor-protective circuit breaker

Oversize motors

We recommend that you use an oversize motor if operating conditions fall outside the operating conditions described in the relevant data booklets available at the Grundfos Product Center.

We especially recommend oversize motors in the following cases:

- The pump is installed at an altitude above 3,500 m (MG IE3), 2,875 m (Innomotics IE3), and 1,000 m (MG IE2).
- The ambient temperature exceeds 60 °C (MG IE3), 55 °C (Innomotics IE3) or 40 °C (MG IE2).
- The viscosity or density of the pumped liquid is higher than that of water.

Related information

[Further documentation](#)

Undersize motors

We recommend that you use an undersize motor if operating conditions fall considerably within the standard conditions described in the relevant data booklets available at the Grundfos Product Center.

We especially recommend undersize motors in the following cases:

- The viscosity or density is lower than that of water.
- The duty point of the pump is constant and the flow rate is significantly lower than the maximum recommended flow rate.

Related information

[Further documentation](#)

Alternative enclosure class (IP)

The motor enclosure class complies with IEC 60034-5.

The enclosure class states the degree of protection of the motor against ingress of solid objects and water.

All motors comply with IP55 as standard.

On request, we offer motors in accordance with IP54, IP56, IP65 and IP66.

IP class	Description
IP54	<ul style="list-style-type: none"> • The motor is protected against the ingress of dust, meaning harmful layers of dust. • The motor is protected against water splashing from any direction.
IP55	<ul style="list-style-type: none"> • The motor is protected against the ingress of dust, meaning harmful layers of dust. • The motor is protected against water being projected by a nozzle from any direction.
IP56	<ul style="list-style-type: none"> • The motor is protected against the ingress of dust. • The motor is protected against heavy seas or high-pressure water jets from any direction.
IP65	<ul style="list-style-type: none"> • The motor is completely dust-proof. • The motor is protected against water being projected by a nozzle from any direction.
IP66	<ul style="list-style-type: none"> • The motor is completely dust-proof. • The motor is protected against heavy seas or high-pressure water jets from any direction.

Alternative terminal box positions

The terminal box is in 6 o'clock position by default. The possible terminal box positions are shown below.

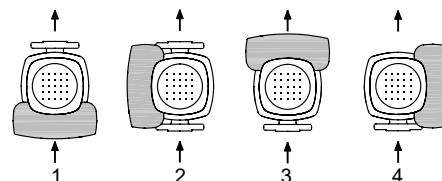

TM033658

Possible terminal box positions

Pos.	Description
1	6 o'clock position (default)
2	9 o'clock position
3	12 o'clock position
4	3 o'clock position

4-pole motors



TM031711

4-pole motor

We offer all CR pumps with 4-pole motors.

4-pole motors are often preferred in the following cases:

- Low level of sound pressure is required.
- Inlet conditions are poor.
- Beating of the liquid is not allowed.

For performance curves and technical data on 4-pole CR pumps, see the section about dimensional drawings.

For electrical data on 4-pole CR pumps, see the sections about standard 4-pole motors for CR, CRI, CRN 50 and 60 Hz .

Related information

[Dimensional drawings for CR pumps](#)

[4-pole motors for CR, CRI, CRN, 50 Hz](#)

[4-pole motors for CR, CRI, CRN, 60 Hz](#)

Permanent magnet motors

CR pumps with MGE IE5 motors are available on request. The offered range spans from 0.37 to 11 kW.

Nidec IE5 motors with frequency drive are available up to 200 kW.

Motor efficiency classes

The new EN standard 60034-30:2009 defines the following efficiency classes of low-voltage three-phase asynchronous motors from 0.75 to 375 kW (IE: International Efficiency):

- IE1: standard efficiency
- IE2: high efficiency
- IE3: premium efficiency
- IE4: super premium efficiency
- IE5: ultra premium efficiency.

Three-phase motors of CR pumps are 0.75 to 200 kW IE3 motors as standard.

CR pumps with IE2, IE4 and IE5 motors are available on request.

Other motor makes

We also offer pumps with a motor of any make that can fulfil requirements with respect to the following:

- flange dimensions
- bearing specifications
- pump shaft.

Alternatively, Grundfos pumps can be supplied without a motor.

7. Shaft seals

Shaft seal arrangements

CR pumps are available with the following shaft seals to meet a wide variety of applications:

- single-seal arrangement
- double-seal arrangement
- magnetic drive.

CR, CRE, CRI, CRIE, CRN and CRNE pumps are fitted with a cartridge shaft seal mounted in a single-seal arrangement as standard:

- HQQE or HQQV (0.25 - 45 kW)
- HBQE or HBQV (55-75 kW).

In applications where the pumped liquid may harm the environment, double-seal arrangements or magnetic-drive pumps are selected.

To ensure reliability, the following conditions must be taken into consideration when selecting a shaft seal:

- operating pressure
- type of pumped liquid
- liquid temperature.

Shaft seal variants

Liquids or applications exceeding the range of normal operating conditions require special-purpose shaft-seal solutions.

In order to meet any specific requirement, we offer variants of seal face material and secondary seal material (rubber parts).

The following recommendations apply to clean water and water containing glycol.

For ultra-pure water (conductivity lower than 2 $\mu\text{S}/\text{cm}$), do not use an xQQx seal face combination. Instead, use an xQUx seal face combination.

FKM (xxxV) is limited to 90 °C in water.

If abrasive particles are present, use an xQQx seal face combination.

Further information on shaft seals

For explanation of codes, shaft seal types and materials, see the type key section, or see the data booklet on mechanical shaft seals available at the Grundfos Product Center.

Data booklet	Link and publication number
Mechanical shaft seals for pumps	http://net.grundfos.com/qr/i/97506935

Overview of shaft seals

The below table shows the available shaft seals.

For information about codes for shaft seals, see the section about type key.

Shaft seal type	Shaft diameter	x = E	x = V	x = K	x = F	
HQQx	Ø12, Ø16	30 bar	30 bar	30 bar	30 bar	
		-40 °C to +120 °C	-20 °C to +90 °C	-5 °C to +120 °C	-10 °C to +120 °C	
	Ø22	30 bar	30 bar	30 bar	30 bar	
		-40 °C to +120 °C	-20 °C to +90 °C	-5 °C to +120 °C	-10 °C to +120 °C	
		30 to 40 bar	30 to 40 bar	30 to 40 bar	30 to 40 bar	
	Ø28, Ø36	-40 °C to +80 °C	-20 °C to +80 °C	-5 °C to +80 °C	-10 °C to +80 °C	
		25 bar	25 bar	-	-	
		-40 °C to +120 °C	-20 °C to +90 °C	-	-	
	HUUx ⁵⁾	Ø12, Ø16	30 bar	30 bar	30 bar	30 bar
			-40 °C to +90 °C	-20 °C to +90 °C	-5 °C to +90 °C	-10 °C to +90 °C
		Ø22	30 bar	30 bar	30 bar	30 bar
			-40 °C to +90 °C	-20 °C to +90 °C	-5 °C to +90 °C	-10 °C to +90 °C
30 to 40 bar			30 to 40 bar	30 to 40 bar	30 to 40 bar	
Ø28, Ø36		-40 °C to +70 °C	-20 °C to +70 °C	-5 °C to +70 °C	-10 °C to +70 °C	
		25 bar	25 bar	-	-	
		-40 °C to +80 °C	-20 °C to +80 °C	-	-	
HQUx ⁶⁾ HUQx ⁷⁾		Ø12, Ø16	30 bar	30 bar	30 bar	30 bar
			-40 °C to +110 °C	-20 °C to +90 °C	-5 °C to +110 °C	-10 °C to +110 °C
		Ø22	30 bar	30 bar	30 bar	30 bar
			-40 °C to +110 °C	-20 °C to +90 °C	-5 °C to +110 °C	-10 °C to +110 °C
	30 to 40 bar		30 to 40 bar	30 to 40 bar	30 to 40 bar	
	Ø28, Ø36	-40 °C to +70 °C	-20 °C to +70 °C	-5 °C to +70 °C	-10 °C to +70 °C	
		25 bar	25 bar	-	-	
		-40 °C to +110 °C	-20 °C to +90 °C	-	-	
	HQBx HUBx	Ø12, Ø16	30 bar	30 bar	30 bar	30 bar
			0 °C to +120 °C	0 °C to +90 °C	0 °C to +120 °C	0 °C to +120 °C
		Ø22	30 bar	30 bar	30 bar	30 bar
			0 °C to +120 °C	0 °C to +90 °C	0 °C to +120 °C	0 °C to +120 °C
30 to 40 bar			30 to 40 bar	30 to 40 bar	30 to 40 bar	
Ø28, Ø36		0 °C to +80 °C	0 °C to +80 °C	0 °C to +80 °C	0 °C to +80 °C	
		25 bar	25 bar	-	-	
		0 °C to +120 °C	0 °C to +90 °C	-	-	
		25 to 40 bar	25 to 40 bar	-	-	
		0 °C to +80 °C	0 °C to +80 °C	-	-	
		0 °C to +80 °C	0 °C to +80 °C	-	-	

5) HUUF Ø22 shaft diameter is available for CR pump sizes 1s-64.

6) HQUx shaft seal types are available for shaft diameters Ø12, Ø16 and Ø22.

7) HUQx shaft seal types are available for shaft diameters Ø22, Ø28 and Ø36.

Related information

[Type key](#)

Single-shaft seals

Single-shaft seals with EPDM O-ring material (HxxE)

We recommend single-shaft seals with EPDM O-ring material for water and aqueous solutions. EPDM rubber is not resistant to mineral oils.

Temperature range for rubber material:

water and watery media from -40 °C to +120 °C.

Single-shaft seals with FKM O-ring material (HxxV)

We recommend single-shaft seals with FKM O-ring material for a wide range of temperatures and pumped liquids, such as acids, saline solutions, mineral oil, vegetable oil and most solvents.

Temperature range for rubber material:

- heat-resistant from -20 °C to +240 °C (oil only)
- water-resistant from -20 °C to +90 °C.

Single-shaft seals with FFKM O-ring material (HxxK)

We recommend single-shaft seals with FFKM O-ring material for a wide range of pumped liquids, such as nitric acid, solvents, varnishes, paints and dyes.

Temperature range for rubber material:

- water-resistant from -5 °C to +275 °C.

Single-shaft seals with FXM O-ring material (HxxF)

We recommend single-shaft seals with FXM O-ring material for high temperatures as well as for acid liquids and gasses within oil and gas extraction.

Temperature range for rubber material:

- 0 to +220 °C.

Plug and sleeve O-rings made of FXM are available for the full range.

Further information on O-ring materials

For further information about O-ring materials, see the relevant data booklets available at the Grundfos Product Center.

Related information

[Further documentation](#)

[Type key](#)

Double-seal arrangements

We offer two double-seal arrangements:

- back-to-back (OQQx)
- tandem (PQQx).

Back-to-back seal arrangement

Back-to-back seal arrangements consist of two Grundfos cartridge shaft seals, type O, fitted back to back in a separate seal chamber.

We recommend this type of seal arrangement for handling the following types of media:

- toxic, aggressive or flammable liquids
- abrasive or sticky liquids that would either wear out, damage or block a mechanical shaft seal.

The back-to-back double seal protects the surrounding environment and the people working in the vicinity of the pump. It is specially designed for operating pressures up to 25 bar and 120 °C to minimise the risk of leakage from the pump to the environment.

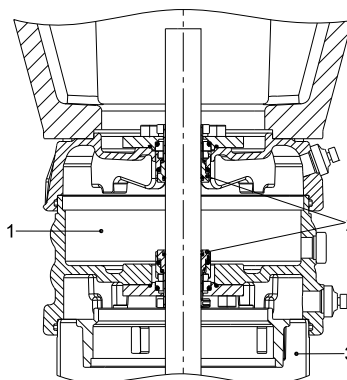

TM044406

CR 32, 45 and 64 with a back-to-back seal arrangement

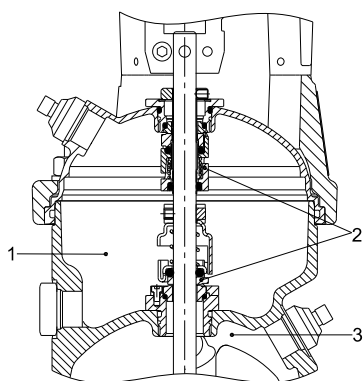

TM044404

CR 1s to 5 with a back-to-back seal arrangement

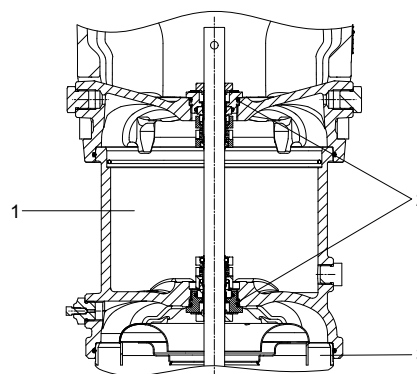

TM072100

CR 95, 125 and 155 with a back-to-back seal arrangement

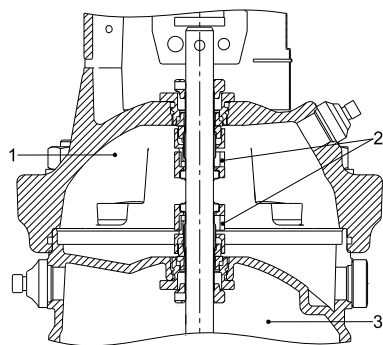

TM044405

CR 10 to 20 with a back-to-back seal arrangement

Key to the above figures

Pos.	Designation
1	Seal chamber
2	Shaft seals
3	Pump

The back-to-back seal arrangement is available for the following CR pumps:

Pump type	CR	CRI	CRN
1s, 1, 3, 5	•	•	•
10, 15, 20	•	•	•
32, 45, 64	•		•
95 ⁸⁾ , 125 ⁸⁾ , 155 ⁸⁾	•		•
185, 215, 255			

⁸⁾ Available for pumps up to and including 55 kW

- Available

Additional height of seal chamber

The following additional heights must be added to the total height of the pump.

Pump type	Additional height of seal chamber [mm]
CRI, CRN 1s, 1, 3, 5	108
CRI, CRN 10, 15, 20	90
CR, CRN 32	140
CR, CRN 45	160
CR, CRN 64	166
CR, CRN 95	209
CR, CRN 125	244
CR, CRN 155	244

For information about the total height of a given CR pump, see the relevant product guides available at the Grundfos Product Center.

Pressurising

In back-to-back seal arrangements, the pressure in the seal chamber must be higher than the pump pressure to prevent the pumped liquid from leaking through the shaft seal to the environment.

Note that the barrier liquid seeps through the lower (primary) shaft seal and mixes with the pumped liquid. Always use the right barrier liquid.

The pressure in the seal chamber can be generated in three ways:

- by an existing pressure source
- by a dosing pump
- by a pressure intensifier.

CR pump with dosing pump in back-to-back seal arrangement

The example below shows a CR pump with a back-to-back seal arrangement. The barrier liquid is supplied and pressurised by a dosing pump.

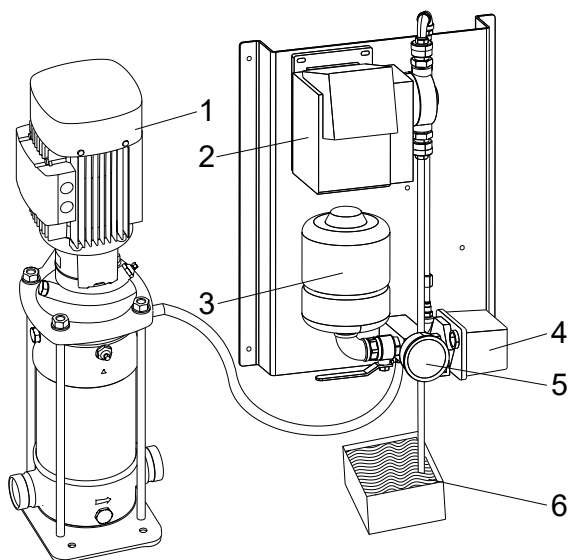

CR pump with a dosing pump

Pos.	Designation
1	Pump
2	Dosing pump
3	Pressure tank
4	Pressure switch
5	Manometer
6	Reservoir with barrier liquid

The setpoint of the barrier-liquid pressure is set by the pressure switch (4). When the pressure drops below the setpoint, the dosing pump starts and thus maintain a higher pressure in the seal chamber (maximum pressure is 16 bar). Barrier liquid is supplied from a reservoir (6). One dosing pump can supply several pumps with back-to-back seal arrangements.

Connections are all RG 1/2.

Note that connecting pipes and hoses are not included.

Dimensions of back plate with components

All dimensions are in millimetres.

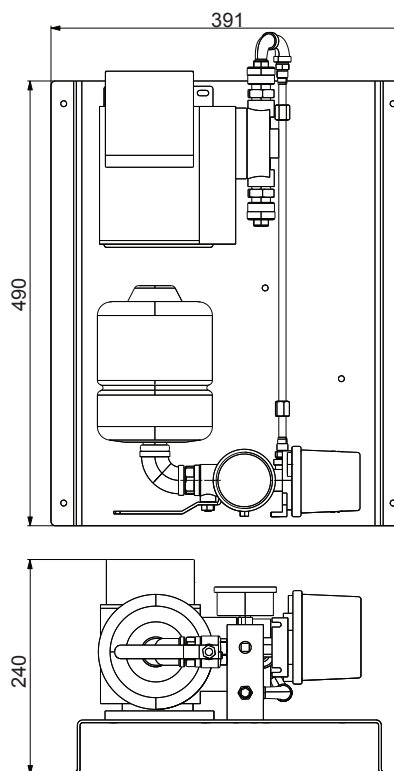

Dimensional sketch of a back plate

Related information

[Further documentation](#)

CR pump with a pressure intensifier in back-to-back seal arrangement



CR pump with a pressure intensifier

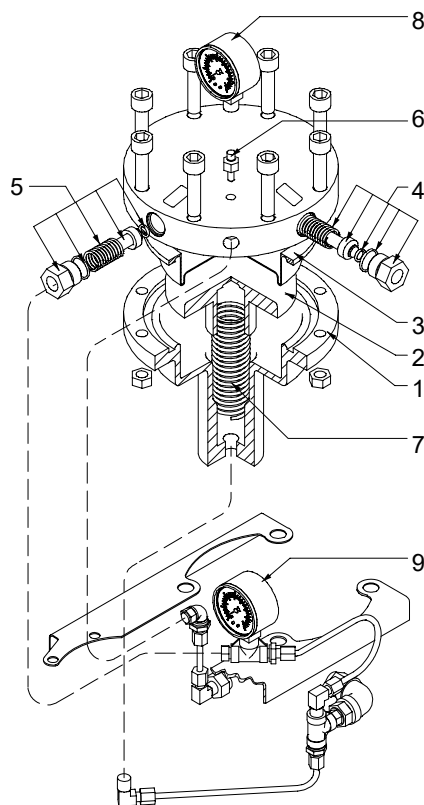

Components of a pressure intensifier

Pos.	Designation
1	Pressure intensifier
2	Piston
3	Diaphragm
4	Non-return valve
5	Relief valve
6	Vent screw, Rp 1/8

Pos.	Designation
7	Spring for piston
8	Pressure gauge (barrier liquid)
9	Pressure gauge (pumped liquid)

The seal chamber is primed with barrier liquid via the non-return valve (4) until the pressure gauge (8) reaches 1.5 to 2 bar. The spring (7) is now preloaded with barrier liquid pressure. The pump is primed and vented. When the pump is started, the pump pressure plus the pressure from the preloaded spring results in a pressure 1.5 to 2 bars higher in the seal chamber.

Note that one pressure intensifier can only supply one pump. The pressure intensifier is fitted on the pump from factory.

Maximum operating pressure: 25 bar.

Dimensions

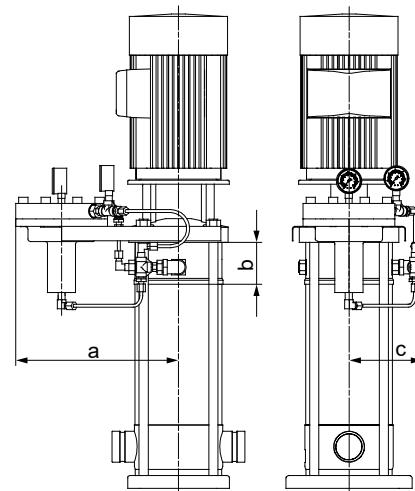

Dimensional sketch of a pump with a pressure intensifier

Pump type	a [mm]	b [mm]	c [mm]
CR, CRI, CRN 1, 3, 5	297	108	128
CR, CRI, CRN 10, 15, 20	330	90	140
CR, CRN 32	342	185	155
CR, CRN 45	349	215	164
CR, CRN 64	349	141	164

The dimension **b** is the additional height compared to the standard pump.

GR5954P_W

TM038299

TM014459

Tandem-seal arrangement

Tandem-seal arrangements consist of two Grundfos cartridge shaft seals, type P, mounted tandem in a separate seal chamber.

We recommend tandem seals for crystallising, hardening or sticky liquids.

The tandem-seal arrangement is specially designed for operating pressures up to 25 bar and 120 °C.

Note that for CR 1s-64 pumps, an option is available for temperatures from 120 °C to 150 °C. The O-ring material in the shaft seal must be FXM (Fluoraz).

CR 1s, 1, 3, 5, 10, 15 and 20

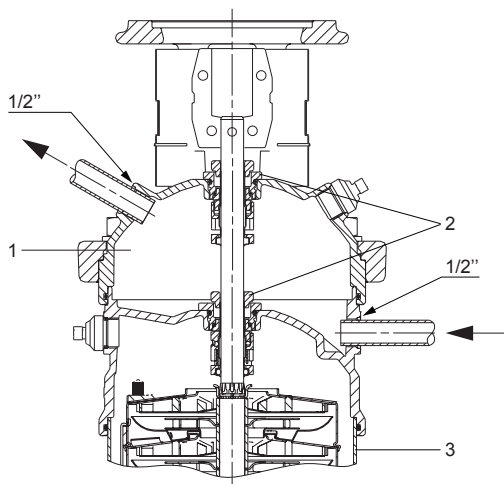

TM033657

CR 1s to 20 with a tandem seal arrangement

CR 32, 45 and 64

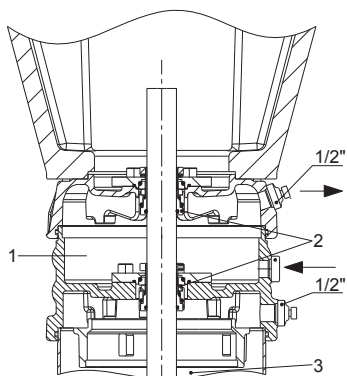

TM044164

CR 32, 45, 64 with a tandem seal arrangement

CR 95, 125 and 155

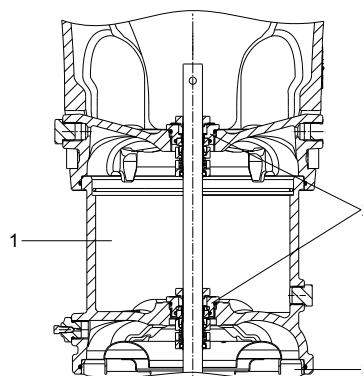

TM072101

CR 95, 125 and 155 with a tandem seal arrangement

Key

Pos.	Designation
1	Seal chamber
2	Shaft seals
3	Pump

The tandem type of seal is available for these CR pumps:

Pump type	CR	CRI	CRN
1s, 1, 3, 5	•	•	•
10, 15, 20	•	•	•
32, 45, 64	•		•
95 ⁹⁾ , 125 ⁹⁾ , 155 ⁹⁾	•		•
185, 215, 255			

⁹⁾ Available for pumps up to and including 55 kW

- Available

Additional height of seal chamber

The following additional heights must be added to the total height of the pump.

Pump type	Additional height of seal chamber [mm]
CRI, CRN 1s, 1, 3, 5	108
CRI, CRN 10, 15, 20	90
CR, CRN 32	140
CR, CRN 45	160
CR, CRN 64	166
CR, CRN 95	209
CR, CRN 125	244
CR, CRN 155	244

For information about the total height of a given CR pump, see the relevant product guides available at the Grundfos Product Center.

Flushing-liquid systems

CR pumps with tandem seal arrangement must be equipped with a flushing-liquid system.

Note that the pumped liquid seeps through the lower (primary) shaft seal and mixes with the flushing liquid.

The flushing-liquid flow rate must also be matched to the application (recommended flow rate 25-200 l/h).

The pressure of the flushing liquid must always be lower than the pressure of the pumped liquid.

Note that the flushing-liquid supply must never be connected directly to the public water-supply system.

Observe the local regulations.

The following figures show examples of flushing systems for tandem-seal arrangements.

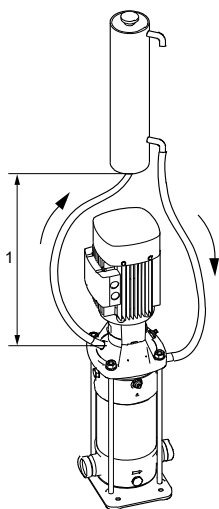

TM078889

Tandem-seal arrangement with circulating flushing liquid

Pos.	Description
1	Minimum 1 metre

In tandem-seal arrangements with circulating flushing liquid, the flushing liquid circulates between an elevated tank and the pump by natural circulation. Heated flushing liquid rises from the seal chamber to the tank where it cools down. The cooled-down flushing liquid returns to the seal chamber.

At high temperatures, the circulation of flushed liquid through the seal chamber cools the seal faces of the shaft seal and reduces noise.

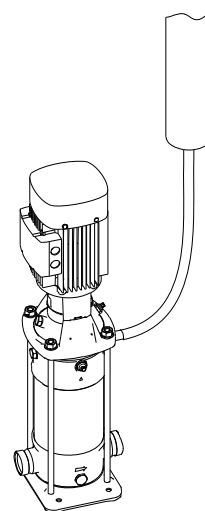

TM078890

Tandem-seal arrangement with a flushing-liquid supply

In tandem-seal arrangements with a flushing-liquid supply, the flushing liquid enters the seal chamber via a pipe from an elevated tank.

No heat is dissipated from the system.

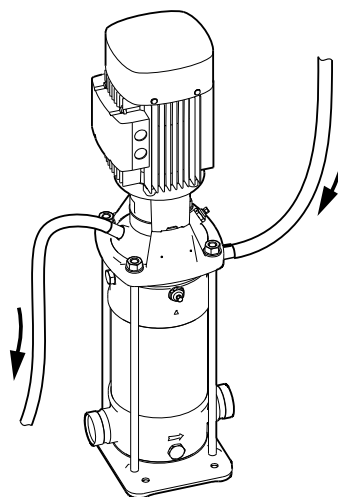

TM033813

Tandem-seal arrangement with flushing liquid connected to a drain

In tandem-seal arrangements with flushing liquid connected to a drain, the flushing liquid enters the seal chamber via a pipe from an elevated tank.

In case of leakage, the pumped liquid is washed away to the drain by the flushing liquid.

Further information

For further information about Grundfos tandem seal arrangements, see the relevant data booklet available at the Grundfos Product Center.

Related information

[Further documentation](#)

[Dosing pump system for barrier fluid](#)

Air-cooled top

CR pumps with an air-cooled top are used where the pumping of hot liquids is crucial for successful production. A CR pump with an air-cooled top is a pump with a special air-cooled shaft-seal chamber generating the same insulation effect as a vacuum flask. No external cooling is necessary, the ambient temperature is sufficient.



GR5228

CR pump with an air-cooled top

CR pumps with an air-cooled top have a mechanical silicon carbide/silicon carbide/EPDM cartridge shaft seal, type HQQE, as standard.

The pumps are able to handle liquid temperatures up to 180 °C at maximum pressure of PN 25 for CR 1s-155 pumps. If the pumped liquid is oil, the pumps can handle liquid temperatures up to 240 °C at maximum PN 16.

The following rubber part variants are available for our air-cooled top solutions:

Pump size	Maximum pressure [bar]	Liquid temperature [°C]	Rubber part material
Water-based liquids			
CR 1s - 64	25	120-150	EPDM
CR 1s - 64	25	150-180	FXM/EPDM
CR 95 - 155	25	120-180	FXM/EPDM
Thermal oils			
CR 1s - 155	16	120-240	FKM

Temperatures above 120 °C normally result in a substantial reduction of seal life due to poor lubrication of the seal faces. As the temperature in the seal chamber does not exceed 120 °C during operation, a standard Grundfos shaft seal can be used.

An automatic vent is required for venting the pump seal chamber.

Note that for safety reasons, you must fit a pipe to lead away steam from the vent to a drain. Observe local regulations.

CR 1s, 1, 3 and 5

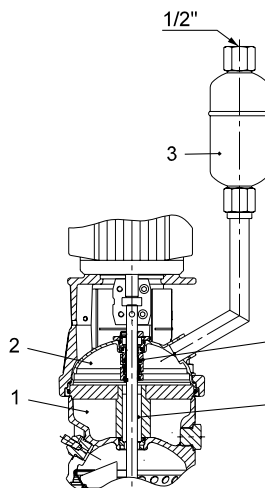

CR 1s, 1, 3 and 5 with an air-cooled top

TM039159

CR 10, 15 and 20

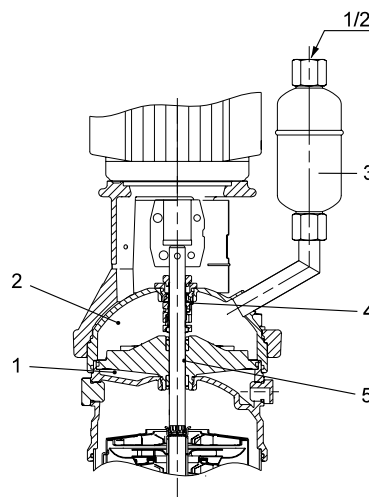

CR 10, 15 and 20 with an air-cooled top

TM039160

CR 32, 45 and 64

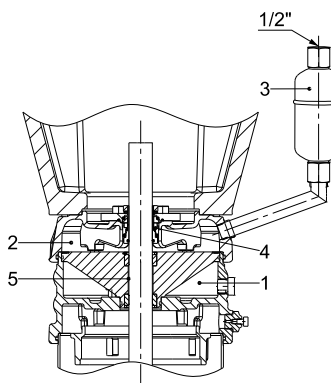

CR 32, 45 and 64 with an air-cooled top

TM044165

CR 95, 125 and 155

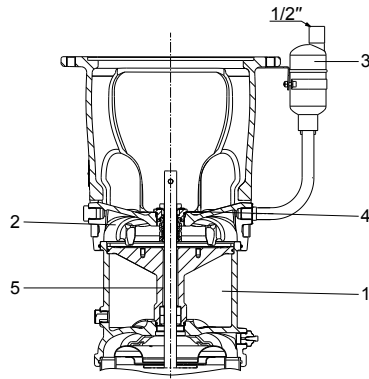

CR 95, 125 and 155 with an air-cooled top

Key

Pos.	Designation
1	Air chamber
2	Liquid
3	Vent
4	Shaft seal
5	Cooling channel

Pump range

The air-cooled top is available for the following pump types:

Pump type	CR	CRI	CRN
1s, 1, 3, 5		•	•
10, 15, 20		•	•
32, 45, 64	•		•
95 ¹⁰⁾ , 125 ¹⁰⁾ , 155 ¹⁰⁾	•		•
185, 215, 255			

¹⁰⁾ Available for pumps up to and including 55 kW

- Available

Bearing flanges for CR pumps with an air-cooled top

When pumping hot liquids, the pump requires a net positive inlet pressure according to the vapour pressure of the specific liquid.

If the vapour pressure of the liquid exceeds the maximum inlet pressure of the pump, a bearing flange is required.

Vent positions on CR pumps with an air-cooled top

The vent of vertical CR pumps with an air-cooled top is in line with the outlet port (12 o'clock position) as standard. The possible vent positions are shown below.

On horizontal pumps, the vent is mounted on top. See the figure Vent positions on horizontal CR pumps with an air-cooled top.

Vertical CR pumps with an air-cooled top

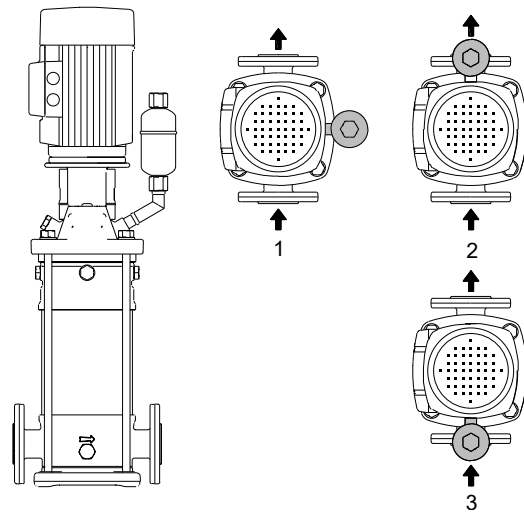

Vent positions on vertical CR 1s-64 pumps

Pos.	Description
1	3 o'clock
2	12 o'clock
3	6 o'clock

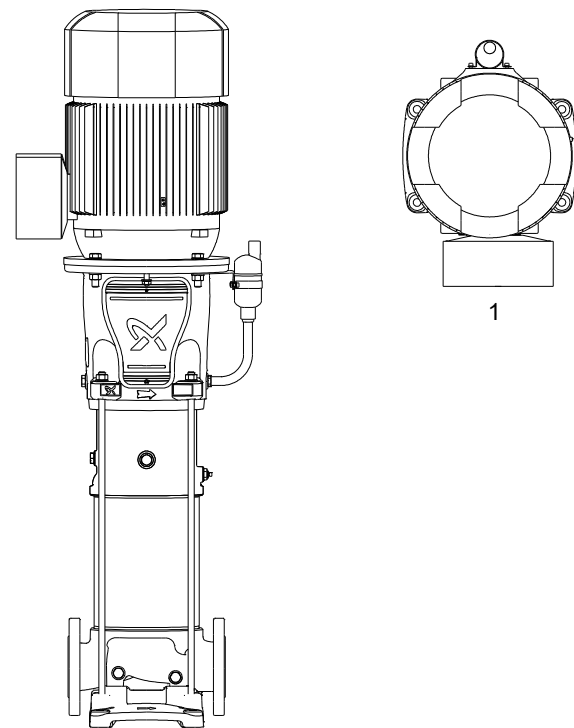

Vent positions on vertical CR 95-155 pumps

Pos.	Description
1	12 o'clock

Dimensions

All dimensions are in millimetres.

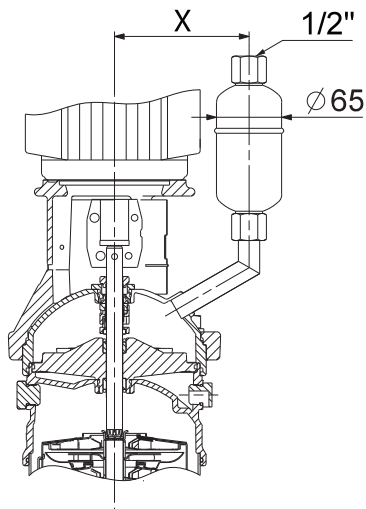

TM034082

Air-cooled top

Pump type	X
CRI, CRN 1s, 1, 3, 5 (< 3 kW)	142
CRI, CRN 1s, 1, 3, 5 (3 - 7.5 kW)	172
CRI, CRN 10, 15, 20 (< 4 kW)	156
CRI, CRN 10, 15, 20 (4 - 7.5 kW)	186
CRI, CRN 10, 15, 20 (11 - 18.5 kW)	217
CR, CRN 32	176
CR, CRN 45, 64	186
CR, CRN 95, 125, 155 (5.5 - 7.5 kW)	220
CR, CRN 95, 125, 155 (11-22 kW)	245
CR, CRN 95, 125, 155 (30-37 kW)	270
CR, CRN 95, 125, 155 (55 kW)	320

Additional pump height

Pump type	Additional pump height
CRI, CRN 1, 3, 5	108
CRI, CRN 10, 15, 20	90
CR, CRN 32	140
CR, CRN 45	160
CR, CRN 64	166
CR, CRN 95	209
CR, CRN 125, 155	244

Horizontal CR pumps with an air-cooled top

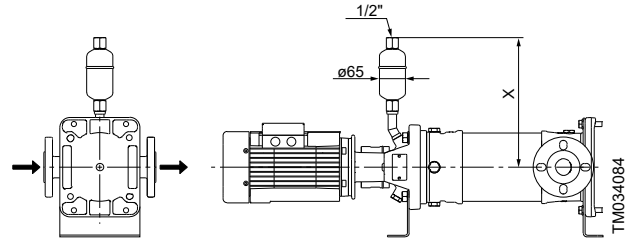

Vent positions on horizontal CR pumps with an air-cooled top

Key to figure Vent positions on horizontal CR pumps with an air-cooled top

Pump type	X
CRI, CRN 1s, 1, 3, 5	308
CRI, CRN 10, 15, 20	324
CR, CRN 32	391
CR, CRN 45, 64	398
CR, CRN 95	356
CR, CRN 125, 155	382

Magnetic-drive pump (MAGdrive)

Grundfos CRN MAGdrive pumps operate according to a patented, magnetic-drive system that eliminates the need for shaft seals. The power from the motor is transmitted to the pump by magnetic force and not by a conventional coupling. Combined with a semi-hermetically sealed liquid end, the pump is essentially leak-free.

As all axial forces are absorbed in the MAGdrive system, the pump incorporates a standard IEC or NEMA motor with keyway and deep-groove ball bearing.



GRA4445

CRN MAGdrive pumps

The MAGdrive solution is available for the following pumps:

Pump type	CRN
1s, 1, 3, 5	•
10, 15, 20	•
32 ¹¹⁾ , 45 ¹¹⁾ , 64 ¹¹⁾	•
95, 125, 155	
185, 215, 255	

¹¹⁾ Available up to 22 kW

- Available

As a minimum, a soft starter is required for the following motors:

- 2-pole motors: 18.5 and 22 kW
- 4-pole motors: 1.1 kW to 11 kW.

Features and benefits

CRN MAGdrive offers the following special features and benefits:

- a semi-hermetically sealed drive system for essentially leak-free pump operation
- a self-regulating heat-tracing cable for eliminating ice formation
- a special choice of materials and design to minimise energy loss
- a simple pump design for ease of service
- a unique pump design for efficient cooling of magnet by the pumped liquid
- an ATEX version available.

Applications

The CRN MAGdrive pump is suitable for a wide selection of industrial applications, such as:

- aggressive or corrosive liquids, for example, concentrated sulphuric acid, nitric acid and phosphoric acid
- toxic liquids, for example, trichloroethylene, chloroform and phenol
- flammable and combustible liquids, for example, petrol, jet fuels, LPG and alcohols
- hardening/curing liquids, for example, paint, glue and resins
- crystallising liquids, for example, glycol additives, naphthalene, sugar products and salts
- refrigerants, for example, ammonia and synthetic chemicals (HCFC, HFC).

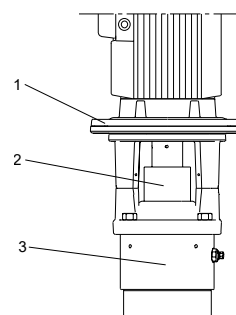

TM039149

MAGdrive system

Pos.	Designation	Materials
1	Motor stool	Cast iron (stainless steel on request)
2	MAGdrive	
3	Pump head	Stainless steel (EN 1.4408)

The configuration of the CRN MAGdrive pump is almost identical to that of the standard CRN pump.

The following rubber parts solutions are available:

- EPDM
- FXM (Fluoraz[®])
- FFKM (Kalrez[®])
- FKM (Viton[®])
- CR (Neoprene)¹²⁾.

¹²⁾ Available for CRN 1-20

The following connections are available for CRN MAGdrive pumps:

Connection type	CRN	
	1s, 1, 3, 5, 10, 15, 20	32, 45, 64
DIN, ANSI, JIS flange	•	•
PJE	•	•
FlexiClamp, union, oval flange, TriClamp	•	

- Available

Construction

The magnetic field is generated by two magnets; the outer magnet is driven by the motor, and the inner magnet is connected to the pump. The two shafts are not connected.

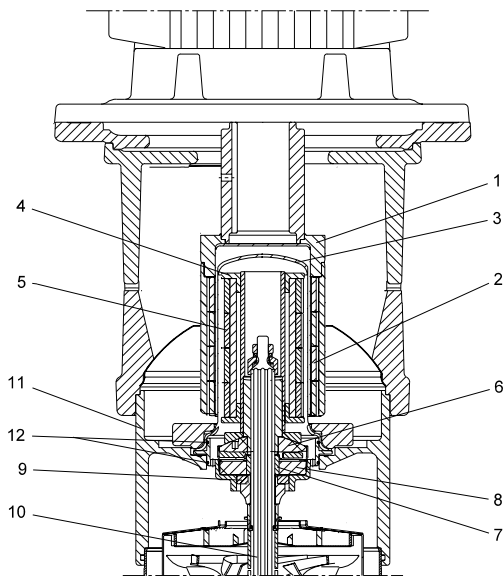

TM039141

Sectional drawing of a MAGdrive system

Pos.	Designation	Material
1	Outer drive	1.4301
2	Outer magnets	NdFeB (neodymium)
3	Can	1.4539
4	Inner drive	1.4401
5	Inner magnets	NdFeB (neodymium)
6	Rotating thrust bearing	SiC Q ₁ ^G (silicon carbide, carbon-filled)
7	Stationary thrust bearing	SiC Q ₁ ^G (silicon carbide, carbon-filled)
8	Radial bearing	SiC (silicon carbide)
9	Upthrust bearing	Graflon (carbon-graphite-filled PTFE)
10	Drive/pump shaft	CRN 1s-5: 1.4401
		CRN 10-20: 1.4460
		CRN 32-64: 1.4462
11	Pump head	1.4408
12	O-ring	EPDM, FKM, FXM, FFKM

Operating conditions

Maximum pressure: 25 bar.
 Temperature range: -40 to +120 °C.
 Viscosity range: 0.15 to 300 mPas.

Technical data

Motor range: 0.37 kW to 22 kW.

Dimensions

The height of the MAGdrive system typically makes the pump a little higher than a standard CRN pump. Some pump sizes have a larger motor than the standard range. For dimensions and weights for CRN MAGdrive pumps, see the section about dimensions and weights.

When ordering a Grundfos MAGdrive, state the following data:

- liquid temperature [°C]
- liquid viscosity [mPas]
- liquid density [kg/m³]
- frequency [Hz].

The above information is required for selecting the correct MAGdrive/motor combination.

Self-regulating heat-tracing cable

In sub-zero ambient temperatures, humidity in the surrounding air may lead to ice formation on the MAGdrive unit. Over time, the ice can block the outer part of the MAGdrive when the pump is stopped. A self-regulating heat-tracing cable mounted in a holder that fits the outer part of the MAGdrive solves this problem by preventing ice formation, reducing the need for time-consuming maintenance and contributing to an improved uptime.

The heat-tracing cable automatically adjusts the heat output in response to increasing or decreasing ambient temperatures, keeping the MAGdrive ice-free and the pump running at all times. It is suitable for use in safe, as well as hazardous or corrosive areas.

The heat-tracing cable is quick and easy to install. Connect the cable to 1 x 220-240 V, 50/60 Hz power supply.

The heat-tracing cable is available for the following CRN MAGdrive pumps:

Pump type	CRN
1s, 1, 3, 5	
10, 15, 20 ¹³⁾	•
32, 45, 64	
95, 125, 155	
185, 215, 255	

¹³⁾ Available up to and including 5.5 kW

- Available

Related information

[Dimensions and weights](#)

8. Pump

PN 25 and PN 40 pumps

We offer customized pump solutions for the following maximum operating pressures:

Pump type	CR [bar]	CRI [bar]	CRN [bar]
1s, 1, 3, 5	25	25	25
10, 15, 20	25	25	25
32, 45, 64	40	-	40
5, 125, 155	30	-	40
185, 215, 255	40	-	40

In applications with high inlet pressures, a bearing flange must be fitted or a high-pressure pump (CR SF) must be used.

For further information, see the high pressure data booklet available at the Grundfos Product Center.

Related information

[Further documentation](#)

Measurement of inlet pressure

As CR 1s to CR 20 pumps are not equipped with a connection for the measurement of pump inlet pressure, we offer customized pumps with a tapping for a pressure gauge or pressure sensor.



CR pump with a pressure gauge

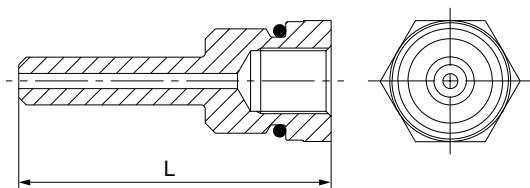

Insert for measurement of inlet pressure

The material of the insert is stainless steel (AISI 316).

Designation	Rubber material	Connection	L [mm]	Product number
CR 1s, 1, 3, 5				
	EPDM			96488082
	FKM	ISO 228-G	57	96562250
	FFKM	1/4"		96562251
	FXM			96562252
CRI, CRN 1s, 1, 3, 5				
	EPDM			96562253
Insert for measurement of inlet pressure	FKM	ISO 228-G	51.5	96562254
	FFKM	1/4"		96562255
	FXM			96562256
	CR 10, 15, 20			
	EPDM	ISO 228-G	62	96584117
	FKM	1/4"		96584119
CRI, CRN 10, 15, 20				
	EPDM	ISO 228-G	53	96584121
	FKM	1/4"		96584122

We offer the following pump types with tapings:

Pump type	CR	CRI	CRN
1s, 1, 3, 5	•	•	•
10, 15, 20	•	•	•
32, 45, 64			
95, 125, 155			
185, 215, 255			

- Available

CR, CRE, CRN, CRNE 32, 45, 64, 95, 125, 155, 185, 215 and 255 have, as standard, connection ports for measurement of pump inlet and outlet pressure.

Pumping of liquids of temperature as low as -40 °C

We offer customized pumps for the pumping of liquids of temperature as low as -40 °C. The pumps have an oversize neck ring ensuring that impellers do not seize up as a result of thermal expansion.

We offer the above solution for the following pump types:

Pump type	CR	CRI	CRN
1s, 1, 3, 5		•	•
10, 15, 20		•	•
32, 45, 64			•
95, 125, 155			•
185, 215, 255			

- Available

TM034726

TM034091

Carbon-free pumps

Certain processes, such as pumping of pure water in electronics industries, require pumps that do not contain carbon.

To meet such requirements, we offer the following 100 % carbon-free pump types:

Pump type	CR	CRI	CRN
1s, 1, 3, 5	○	○	○
10, 15, 20	○	○	○
32, 45, 64	●		●
95, 125, 155	●		●
185, 215, 255	●		●

● Available

○ Pumps with an HQQx shaft seal are carbon-free as standard

CRN all-stainless steel pumps

We offer customized stainless steel CRN pumps for maritime applications and very humid environments:

- pump with stainless steel motor stool
- pump with stainless steel base
- pump with stainless steel flanges.

The dimensions of customized stainless steel CRN pumps do not differ from those of standard CRN pumps.

We offer the above solutions for the following pump types:

Pump type	CR	CRI	CRN
1s, 1, 3, 5			●
10, 15, 20			●
32, 45, 64			●
95 ¹⁴⁾ , 125 ¹⁴⁾ , 155 ¹⁴⁾			●
185 ¹⁴⁾ , 215 ¹⁴⁾ , 255 ¹⁴⁾			●

¹⁴⁾ For CR, CRN 95 - 255, we do not offer a stainless steel motor stool.

Instead, we offer improved corrosion protection in form of painted coating. See corrosion protection standard and categories in the section on surface treatment.

● Available

Surface treatment

Overview of applications and corresponding surface treatments.

Applications	Surface treatment					
	Cleaned and dried	Cleaned and dried, PWIS free	Vacuum-dried	Electropolished	Alternative colouring	Corrosion protection
Offshore						•
Pharmaceutical industry	•	•		•		
Food and beverage industry						
Automotive industry		•				
Cooling industry			•			

Cleaned and dried pumps

Cleaned and dried pumps are used in applications involving strict demands for cleanliness and surface quality, such as low content of silicone.

To meet these strict demands, we offer the following cleaned and dried pump types:

Pump type	CRI	CRN
1s, 1, 3, 5	•	•
10, 15, 20	•	•
32, 45, 64		•
95, 125, 155		
185, 215, 255		

• Available

Before being assembled, all pump parts are cleaned in 60 to 70 °C water with a cleaning agent. All pump parts are then thoroughly rinsed in de-ionised water and air-dried. The pump is assembled without any use of silicone lubricants. Finally, the pump is packed in silicone-free plastic.

De-oiled shaft seals are available as an option for CRI, CRN 1s to 64 pumps.

CRN 95 to 255 pumps that are ordered as cleaned and dried, and PWIS-free, are fitted with a de-oiled shaft seal as standard.

PWIS means Paint-Wetting Impairment Substances.

The term is used to describe substances that inhibit or destroy the ability of paint to adhere to surfaces.

A PWIS-free environment is mainly required in the automotive industry and in paint shops.

PWIS-free pumps are manufactured according to the specifications below:

- All components of the pump, including shaft seal, motor, rubber materials for shaft seals, do not contain or release PWIS.
- Before being assembled, pump components are washed in pure, hot soap water, rinsed in de-ionised water and dried.
- Consumables like oil, grease and soap water not containing PWIS, are used during assembly.

- Tools for product assembly do not contain any PWIS.
- The product is not performance tested.
- The finished product is wrapped in a special PWIS-free plastic bag before being packed for shipment.

We offer the following PWIS-free pumps:

Pump type	CRI	CRN
1s, 1, 3, 5		•
10, 15, 20		•
32, 45, 64		•
95, 125, 155		•
185, 215, 255		•

• Available

Vacuum-dried pumps

In general, all CR products are tested before leaving the assembly line.

After the test, all pumps are drained. Due to the design of the chamber stack, it is not possible to completely drain the product. Primarily within cooling applications, no residual water from the test is accepted in the pump, and all pumps must be completely dry. After the pump performance test, vacuum-dried pumps are therefore handled as described below:

1. Water is blown out of the pump with compressed air.
2. The pump is ventilated with hot air for a predefined period of time.
3. The pump is exposed to vacuum for a predefined period of time.
4. The humidity inside the pump is measured.

If necessary, steps 2 and 3 are repeated until the humidity level reaches a predefined value ensuring no liquid is present inside the pump.

We offer the following vacuum-dried pumps:

Pump type	CR	CRI	CRN
1s, 1, 3, 5	•	•	•
10, 15, 20, 32	•	•	•
45, 64			
95, 125, 155			
185, 215, 255			

- Available

Electropolished pumps

Electropolished pumps are often used in the pharmaceutical industry and in the food and beverage industry where materials and surface quality must meet strict requirements with respect to hygiene or corrosion resistance.

Electropolishing removes burrs as well as metallic and non-metallic inclusions, providing a smooth, clean and corrosion-resistant stainless steel surface.

First, all components are pickled in a mixture of nitric and hydrofluoric acid. Subsequently, the components are electropolished in a mixture of sulphuric and phosphoric acid. Finally, the components are passivated in nitric acid.

All cast parts of CRN 1s-20 pumps are polished mechanically before being electropolished.

Note that the pump incorporates a standard shaft seal that has not been polished.

To meet the strict hygienic requirements about material and surface quality, we offer electropolished stainless steel CRN pumps with the following surface quality:

Pump type	Cast stainless steel parts	Stainless steel parts	Surface quality (Ra) [µm]
CRN 1s, 1, 3, 5	•	•	≤ 0.8
CRN 10, 15, 20	•	•	≤ 0.8
CRN 32, 45, 64	•		≤ 8.0
		•	≤ 0.8
CRN 95-255 ¹⁵⁾	•		≤ 8.0
		•	≤ 0.8

¹⁵⁾Pumps with 75 kW motor size and up require a bearing flange.

- Available

We offer the following electropolished pumps:

Pump type	CR	CRI	CRN
1s, 1, 3, 5			•
10, 15, 20			•
32, 45, 64			•
95, 125, 155			•
185, 215, 255			•

- Available

Alternative colouring

We offer customized pumps in any NCS- or RAL-specified colour to suit your requirements.

The used paint is water-based. Painted parts comply with corrosion class III.

All pump types and sizes are available with alternative colouring.

Corrosion protection

We offer corrosion protection in form of painting and in several categories according to the specific requirements of the pump installation.

The categories refer to area or environment, layer thickness and lifetime expectancy.

Corrosion protection is according to DS/EN ISO standard 12944.

Corrosion category	Validity	Chemical resistance test	Tropical test	Salt mist test
		[hours]	[hours]	[hours]
C2	Low	-	48	-
	Medium	-	48	-
	High	-	120	-
C3	Low	-	48	120
	Medium	-	120	240
	High	-	240	480
C4	Low	-	120	240
	Medium	-	240	480
	High	-	480	720
C5-I	Low	168	240	480
	Medium	168	480	720
	High	168	720	1440
C5-M	Low	-	240	480
	Medium	-	480	720
	High	-	720	1440

CR low NPSH

Cavitation is often a problem in applications where pumps have to deal with the combination of high liquid temperatures, poor inlet pressure and a high flow rate.

For further information about NPSH and the calculation of the NPSH value, see the relevant data booklets available at the Grundfos Product Center.

Low-NPSH pumps are designed to reduce the risk of cavitation and ensure stable and reliable operation.

The CR low-NPSH pump is a pump with a special first-stage design that reduces the NPSH value of the pump and prevents erosion and destruction of the pump, pipes and valves. Due to the improved inlet design, low-NPSH pumps can handle more stress than conventional pumps, without affecting the stability of operation.

The CR low-NPSH pump reduces the excess pressure itself and does not require an additional tank to provide supplementary pressure. In boiler feed applications where many large tanks are gathered, a compact system is an advantage.

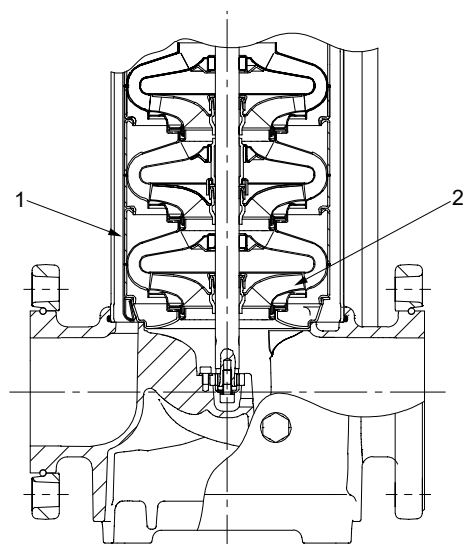

TM034063

Sectional drawing of a CR low-NPSH pump

Key

Pos.	Designation
1	Special inlet part
2	Special inlet impeller

Pump range

The following pump types are available as low-NPSH pumps:

Pump type	CR	CRI	CRN
1s, 1			
3, 5	•	•	•
10, 15, 20	•	•	•
32, 45, 64	•		•
95, 125, 155			
185, 215, 255			

• Available

Maximum pressure	25 bar
Maximum liquid temperature	120 °C ¹⁶⁾

¹⁶⁾ With an air-cooled top, the maximum liquid temperature is +180 °C.

Related information

[Further documentation](#)

[Low-NPSH pumps, 50 Hz](#)

[Low-NPSH pumps, 60 Hz](#)

[Dimensions and weights](#)

Horizontal in-line pumps



GR5379_HORIZONTAL

Horizontal CR pump

Horizontal pumps are used in applications for safety or space-saving reasons.

In areas prone to earthquakes, horizontal pumps are more reliable than vertical pumps. In case of earthquake, the design and mounting of the pump dampens the oscillations of the pump.

In installations with limited access or space, we recommend horizontal pumps to improve installation and service.

Pump range

The following Grundfos pumps are available for horizontal mounting:

Pump type	CR	CRI	CRN
1s, 1, 3, 5	•	•	•
10, 15, 20	•	•	•
32, 45, 64	•		•
95, 125, 155	•		•
185, 215, 255	•		•

- Available

Dimensions of horizontal in-line pumps

All dimensions are in millimetres.

CR, CRE, CRI, CRIE, CRN, CRNE 1s, 1, 3, 5 (≤ 4 kW)

CR, CRE, CRI, CRIE, CRN, CRNE 10, 15, 20 (≤ 4 kW)

CR, CRE, CRI, CRIE, CRN, CRNE 5 (5.5 - 7.5 kW)

CR, CRE, CRI, CRIE, CRN, CRNE 10, 15, 20 (≥ 5.5 kW)

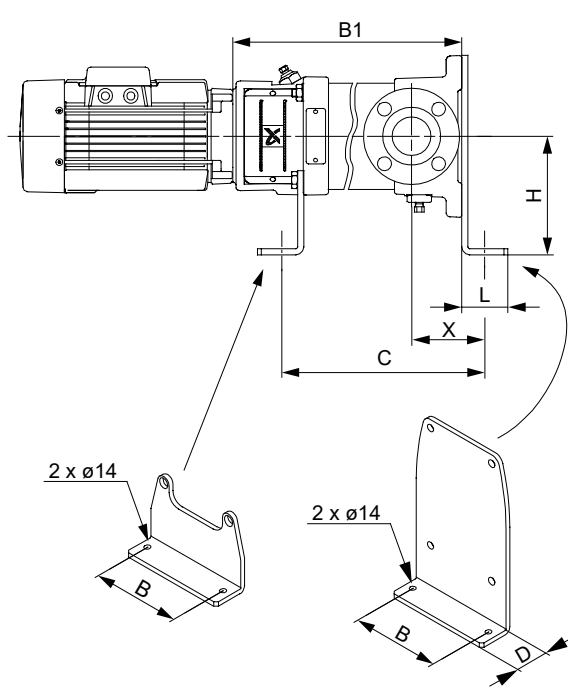

TM034641

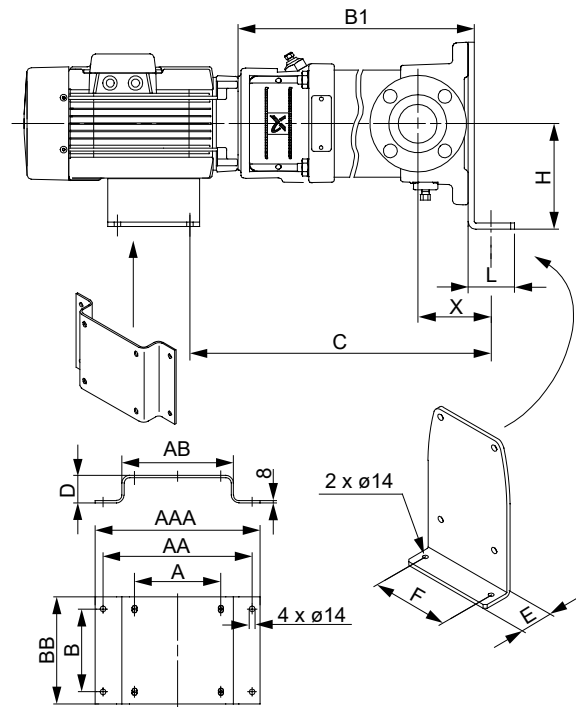

TM034642

CR, CRE, CRI, CRIE, CRN, CRNE 1s, 1, 3, 5 (≤ 4 kW), support for base plate and pump head

Motor [kW]	B	C	D	H	L	DIN	Oval, PJE, FlexiClamp
						X	X
0.37 - 0.55	138	B1-58	45	140	50	105	80
0.75 - 1.1		B1-64	45				
1.5 - 2.2		B1-80	45				
3-4		B1-84	45				

For pump height (B1) and for combined pump and motor height (B1+B2), see the CR, CRI, CRN or the CRE, CRIE, CRNE data booklet.

CR, CRE, CRI, CRIE, CRN, CRNE 5 (5.5 - 7.5 kW)

Motor [kW]	A	AA	AAA	AB	B	BB	C	D	E	F	H	L	DIN	Oval
													X	X
5.5	216	326	366	276	140	180	B1+119	68	45	138	200	50	105	80
7.5	216	326	366	276	140	180	B1+119	68	45	138	200	50		

For pump height (B1) and for combined pump and motor height (B1+B2), see the CR, CRI, CRN or the CRE, CRIE, CRNE data booklet.

CR, CRE, CRI, CRIE, CRN, CRNE 10, 15, 20 (≤ 4 kW), support for base plate and pump head

CR, CRE, CRI, CRIE, CRN, CRNE												
Motor [kW]	B	C	D	H	L	10		15, 20				
						DIN, oval, PJE, FlexiClamp		DIN, oval, PJE, FlexiClamp				
						X		X				
0.37 - 0.55	170	B1-65	45	174	50							
0.75 - 1.1		B1-69	45			110		120				
1.5 - 2.2		B1-84.5	45									
3-4		B1-89.5	45									

For pump height (B1) and for combined pump and motor height (B1+B2), see the CR, CRI, CRN or the CRE, CRIE, CRNE data booklet.

CR, CRE, CRI, CRIE, CRN, CRNE 10, 15, 20 (≥ 5.5 kW), support for base plate and motor

CR, CRE, CRI, CRIE, CRN, CRNE																
Motor [kW]	A	AA	AAA	AB	B	BB	C	D	E	F	H	L	10		15, 20	
													DIN, oval, PJE, FlexiClamp		DIN, oval, PJE, FlexiClamp	
													X		X	
5.5	216	326	366	276	140	180	B1+119	68	45	170	200	50				
7.5	216	326	366	276	140	180	B1+119	68	45	170	200	50				
11	254	384	424	334	210	260	B1+138	40	45	170	200	50	110			120
15	254	384	424	334	210	260	B1+138	40	45	170	200	50				
18.5	254	384	424	334	254	310	B1+138	40	45	170	200	50				

For pump height (B1) and for combined pump and motor height (B1+B2), see the CR, CRI, CRN or the CRE, CRIE, CRNE data booklet.

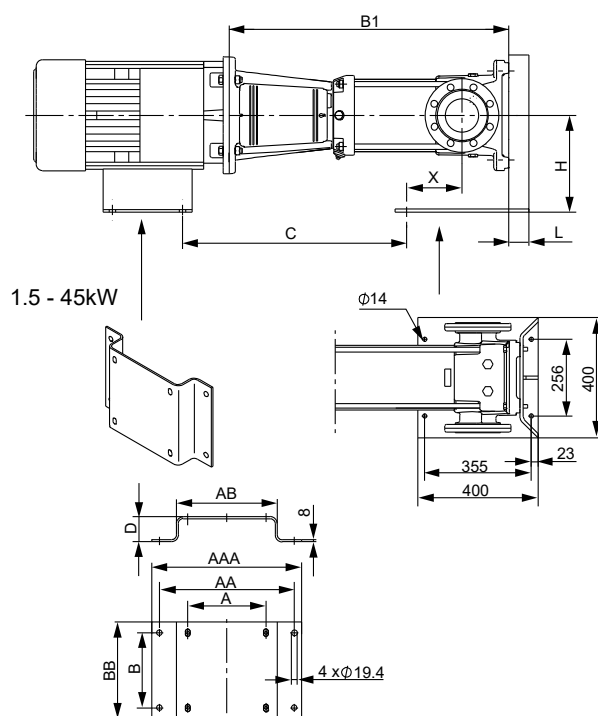
CR, CRE, CRN, CRNE 32, 45, 64 (≤ 45 kW), support for base plate and motor

TM073804

Motor [kW]	A	AA	AAA	AB	B	BB	C	D	E	H	L	CRE, CRNE, CRN, CRNE	
												32	45, 64
												DIN X	DIN X
1.5	140	320	380	220	100	165	B1-261	200	400				
2.2	140	320	380	220	125	165	B1-261	200	400				
3	160	340	400	245	140	180	B1-254	190	400				
4	190	370	430	275	140	180	B1-247	178	400				
5.5	216	395	455	300	140	180	B1-228	158	400				
7.5	216	395	455	300	140	180	B1-228	158	400				
11	254	440	500	340	210	275	B1-209	130	400	290	60	212	177
15	254	455	515	340	210	266	B1-209	130	400				
18.5	254	455	515	340	254	310	B1-209	130	400				
22	279	485	545	365	240	310	B1-196	110	400				
30	318	540	600	410	305	365	B1-184	90	400				
37	318	540	600	410	305	365	B1-184	90	400				
45	356	580	640	450	310	370	B1-168	65	400				

For pump height (B1) and for combined pump and motor height (B1+B2), see the CR, CRI, CRN or the CRE, CRIE, CRNE data booklet.

CR, CRE, CRN, CRNE 95, 125, 155, support for base plate and motor

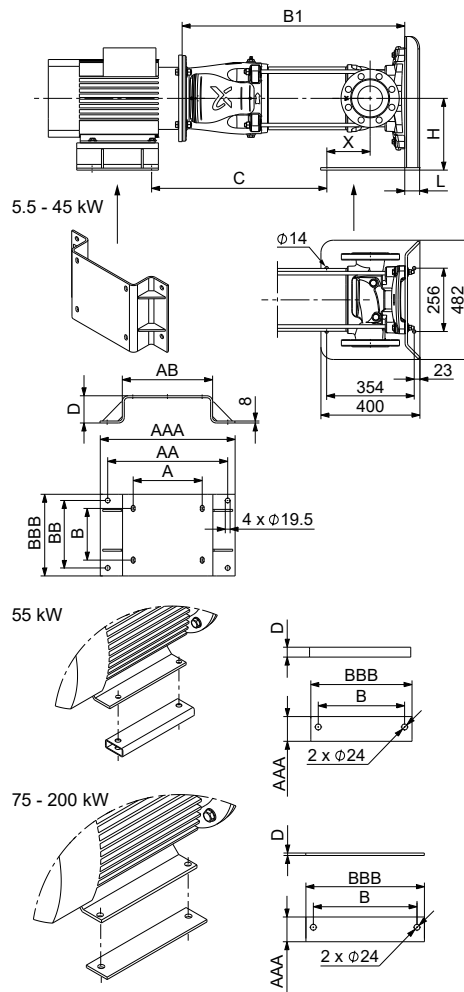

TM072097

													CR, CRE, CRN, CRNE	
													95	125, 155
Motor [kW]	A	AA	AAA	AB	B	BB	BBB	C	D	H	L	DIN	DIN	
												X	X	
5.5	216	395	455	300	140	140	195	B1-234	158	290	60	177	-	
7.5	216	395	455	300	140	140	195	B1-234	159	290	60	177	-	
11	254	440	500	340	210	210	270	B1-212.5	130	290	60	177	137	
15	254	455	515	340	210	210	270	B1-212.5	130	290	60	177	137	
18.5	254	455	515	340	254	254	310	B1-214.5	130	290	60	177	137	
22	279	485	545	365	241	241	330	B1-185	110	290	60	177	137	
30	318	540	600	410	305	305	370	B1-185	90	290	60	177	137	
37	318	540	600	410	305	305	370	B1-185	90	290	60	177	137	
45	356	580	640	450	311	311	370	B1-172	65	290	60	177	137	
55	406	-	-	-	349	-	409	B1-182.5	40	290	60	177	137	
75	457	-	-	-	368	-	479	B1-127	10	290	60	177	137	
90	457	-	-	-	419	-	479	B1-127	10	290	60	177	137	
110	508	-	-	-	406	-	535	B1-101	20	335	60	-	137	
132	508	-	-	-	457	-	655	B1-101	20	335	60	-	137	
160	508	-	-	-	457	-	655	B1-101	20	335	60	-	137	
200	508	-	-	-	457	-	655	B1-101	20	335	60	-	137	

For pump height (B1) and for combined pump and motor height (B1+B2), see the CR, CRI, CRN or the CRE, CRIE, CRNE data booklet.

CR, CRE, CRN, CRNE 185, 215, 255, support for base plate and motor

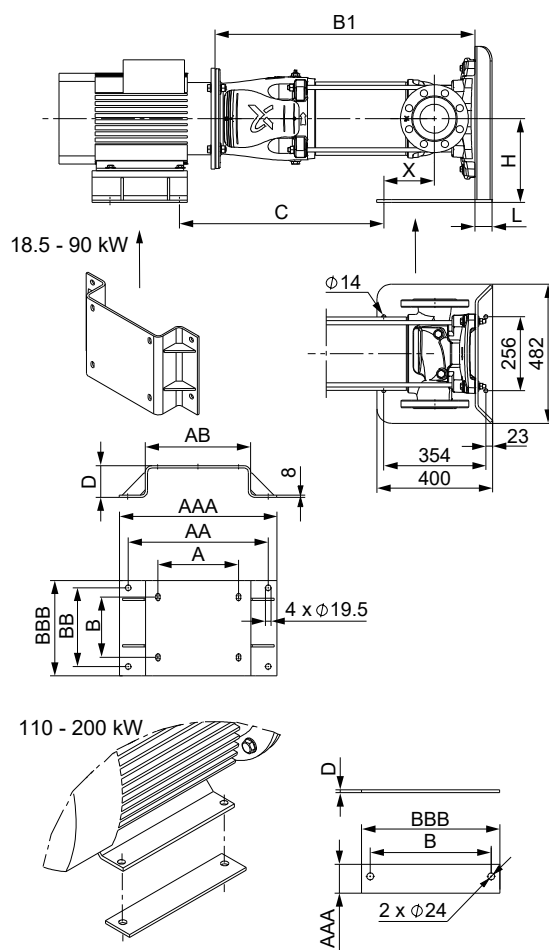

TM077447

Motor [kW]	A	AA	AAA	AB	B	BB	BBB	C	D	H	L	DIN
												X
18.5	254	455	515	340	254	254	310	B1-214.5	175	335	60	117
22	279	485	545	365	241	241	330	B1-185	155	335	60	117
30	318	540	600	410	305	305	370	B1-185	135	335	60	117
37	318	540	600	410	305	305	370	B1-185	135	335	60	117
45	356	580	640	450	311	311	370	B1-172	110	335	60	117
55	406	625	685	530	349	349	420	B1-147	85	335	60	117
75	457	675	735	545	368	368	490	B1-99.5	85	335	60	117
90	457	675	735	545	419	419	490	B1-125	55	335	60	117
110	508	-	-	-	406	-	535	B1-101	20	335	60	117
132	508	-	-	-	457	-	655	B1-101	20	335	60	117
160	508	-	-	-	457	-	655	B1-101	20	335	60	117
200	508	-	-	-	457	-	655	B1-101	20	335	60	117

For pump height (B1) and for combined pump and motor height (B1+B2), see the CR, CRI, CRN or the CRE, CRIE, CRNE data booklet.

Related information

[Further documentation](#)

Multistage horizontal end-suction pumps



TM051717

Multistage horizontal end-suction pumps

CR-H, CRI-H, CRN-H 50/60 Hz

CR-H, CRI-H, CRN-H pumps are horizontal end-suction pumps typically mounted on base plates. The pumps are available in a complete 50 and 60 Hz range with both IEC or NEMA motors.

Interchangeable ANSI solution

The patented loose-flange concept provides easy installation in ANSI, DIN or JIS standard pipes.

Pump connection configurations comply with the ANSI/ASME B73.1 standard, and ensure interchangeability with traditional end-suction pumps with an axial inlet port and radial centre-line outlet port. This makes the CR-H a high-efficiency solution designed for drop-in replacement of ANSI-configured pumps. The back pull-out design enables service of most versions without removing the base from the pipes.

CR-H, CRI-H, CRN-H pumps are suitable for a variety of applications from pumping drinking water to pumping chemicals. The pumps are therefore used in a wide variety of pumping systems where the performance and material of the pump must meet specific demands.

Energy efficiency

To reduce loss and increase pump efficiency, CR-H, CRI-H, CRN-H pumps are available in an energy-optimised version with inlet and outlet ports with a larger diameter than ANSI specifications.

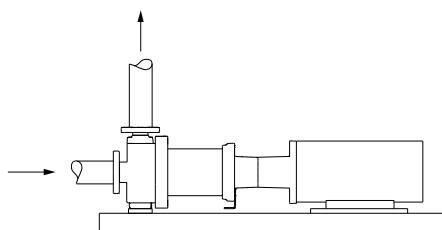

TM051378

CR-H pump with an axial inlet port and radial outlet port

Maximum pressure: 30 bar.

Maximum liquid temperature: 120 °C. Note that CR pumps with an air-cooled top have a maximum liquid temperature of 180 °C (240 °C for oil).

Maximum motor size: 45 kW.

Terminal box positions

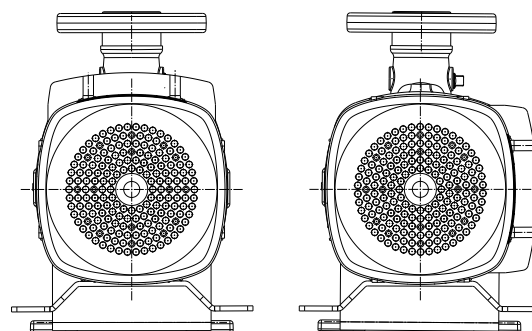

TM051988

IEC motor

Pump type	CR-H	CRI-H	CRN-H
1s, 1, 3, 5	•	•	•
10, 15, 20	•	•	•
32, 45, 64	•		•
95, 125, 155			
185, 215, 255			

For dimensions of CR-H pumps with IEC motors, see the section on CR-H, CRN-H pumps.

NEMA motor

Pump type	CR, CR-H	CRN, CRN-H
1s, 1, 3, 5	•	•
10, 15, 20	•	•
32, 45, 64	•	•
95, 125, 155		
185, 215, 255		

For dimensions of CR-H pumps with NEMA motors, see the Grundfos Product Center.

Related information

[Dimensional drawings for CR-H, CRN-H pumps](#)

Variants

The same variants and accessories are available for the CR-H, CRI-H, CRN-H pump range as for the standard CR pump range. The only difference between the CR horizontal end-suction pump and the CR in-line pump is the base. However, the base for horizontal end-suction pumps is not available in titanium.

Construction

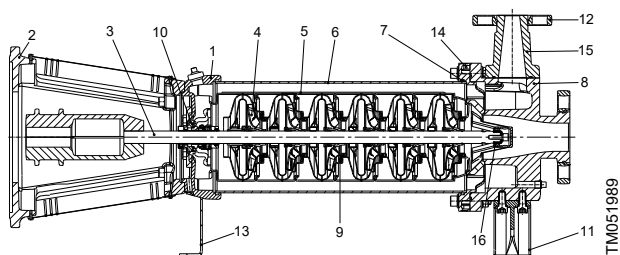

Sectional drawing

Pos.	Designation	Pos.	Designation
1	Pump head	9	Neck ring
2	Motor stool	10	Shaft seal
3	Shaft	11	Foot
4	Impeller	12	Flange ring
5	Chamber	13	Support bracket
6	Sleeve	14	Sleeve flange
7	O-ring for sleeve	15	Outlet port
8	Base	16	Bottom bearing ring

Belt-driven pumps

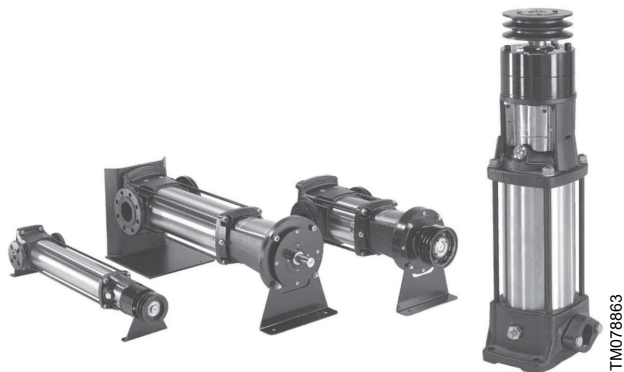

TM078863

Belt-driven CR pump

Belt-driven pumps are used in applications for space-saving reasons, or where no electrical power is available. The belt-driven pump has a pulley for connection to an internal combustion engine. The belt-driven CR pumps are of the same construction as, electrically driven CR pumps.

Pump range

The following Grundfos pumps are available as belt-driven pumps:

Pump type	CR	CRI	CRN
1s, 1, 3, 5	•	•	•
10, 15, 20	•	•	•
32, 45, 64	•		•
95, 125, 155			
185, 215, 255			

- Available

An additional bearing has been added on top of an existing bearing flange. The two bearings are fitted back to back. This bearing design makes it possible to withstand the extra radial forces caused by a pulley.

A pulley can be attached to the end of the shaft.

Note that the pulley is not supplied with the pump.

By pulley belts, the pump can be driven by a motor mounted next to it rather than on top of it.

The pump can be mounted horizontally or vertically by the extra support plates.

The pulley head is positioned on the motor stool where the motor would normally be fitted. By the existing holes in the motor stool, the pulley head can be secured to the motor stool with bolts, washers and nuts. The pulley wheel is then attached to the shaft using an appropriate bush and key.

For extended bearing life, we recommend the following pulley wheel sizes:

	Type III	Type IV	Type II	Type I
Pulley head	0.37 - 5.5 [kW]	7.5 - 18.5 [kW]	1.5 - 7.5 [kW]	11 - 45 [kW]
Pump type	CR, CRI, CRN		CR, CRN	
Pulley wheel diameter	1s, 1, 3, 5, 10, 15, 20	10, 15, 20	32, 45, 64	
V-belts	2	Min. 3	Min. 2	Min. 3
Pump speed rpm	Max. 3000			

Dimensional drawings

All dimensions are in mm.

CR, CRI, CRN 1s, 1, 3 and 5 (type III)

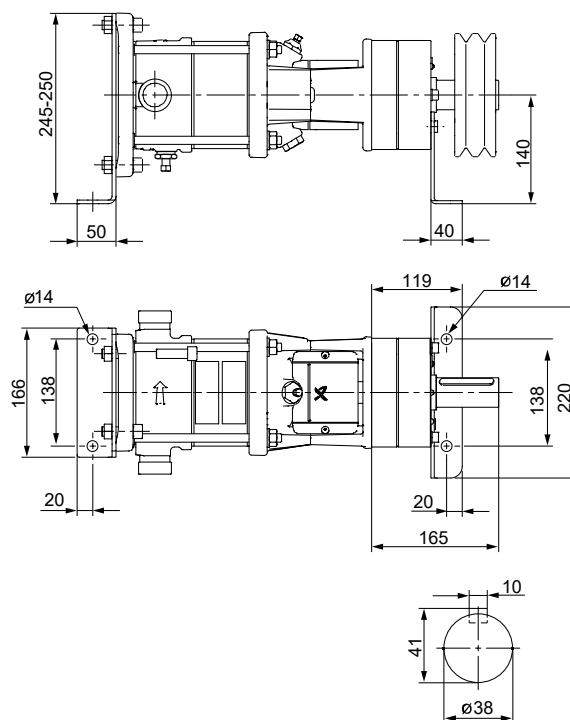

TM034137

CR, CRI, CRN 10, 15 and 20 (type III)

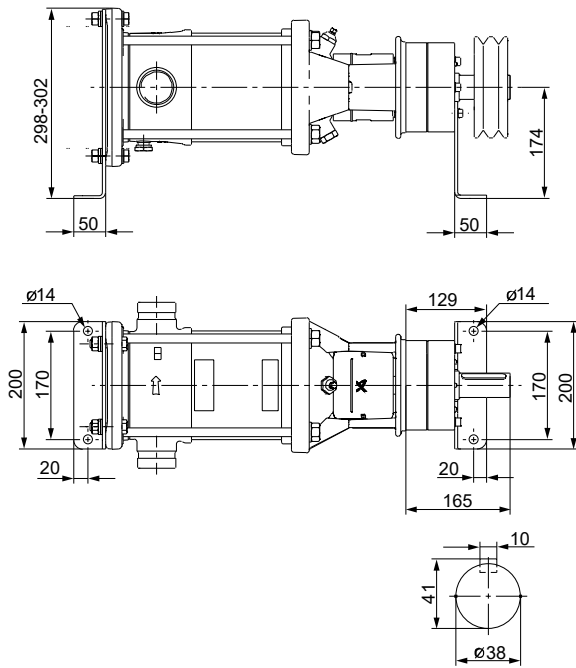

TM034168

CR, CRN 32, 45 and 64 (type II)

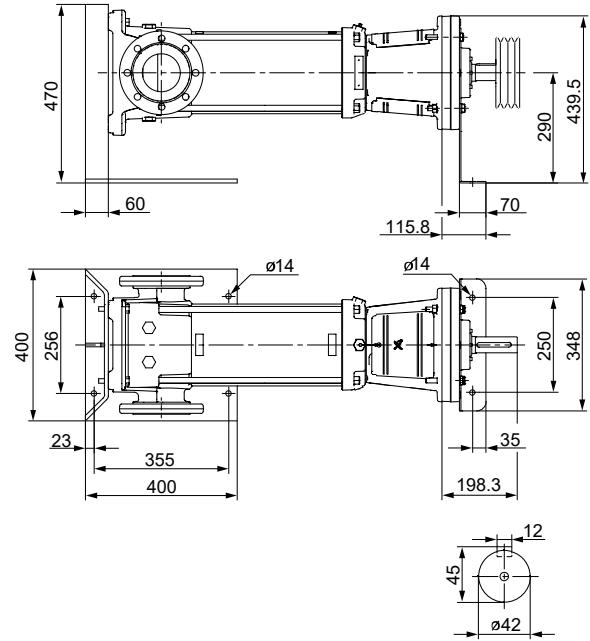

TM034170

CR, CRI, CRN 10, 15 and 20 (type IV)

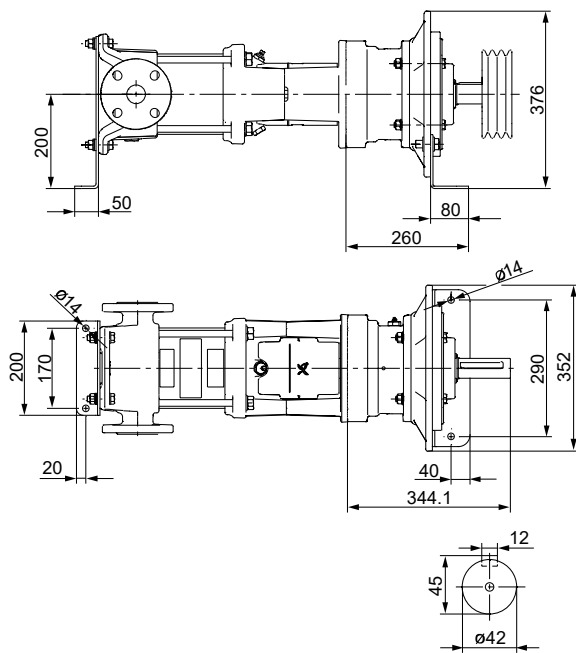

TM034169

CR, CRN 32, 45 and 64 (type I)

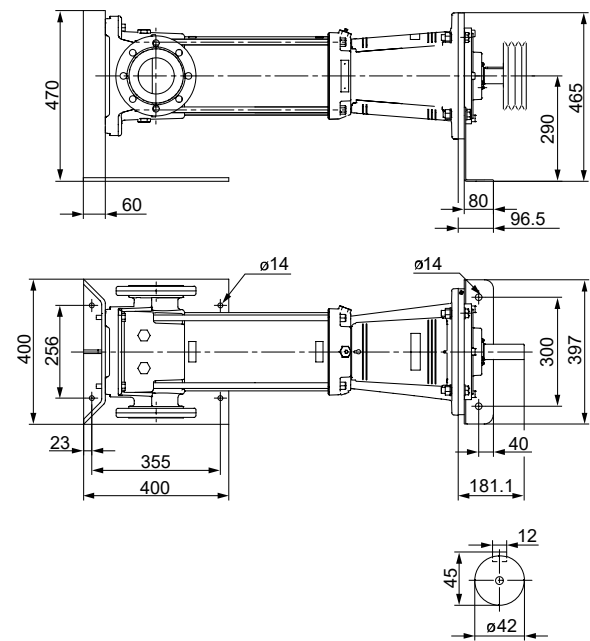

TM034171

CR, CRI deep-well pumps

CR, CRI deep-well pumps are used for deep-well pumping in small water supply systems where water is pumped from depths (H_D) down to 90 metres.

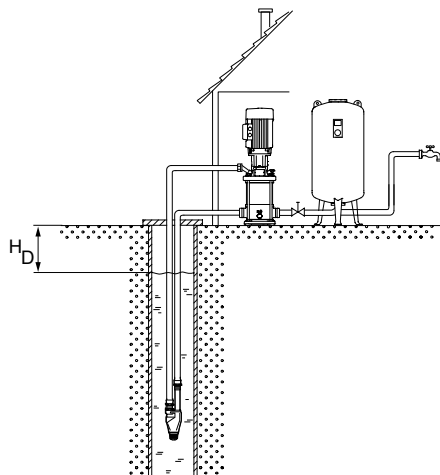

System with a CR, CRI deep-well pump

The pump system consists of a dry-installed CR, CRI multistage centrifugal pump connected to a one-size submerged ejector via two pipes.

We recommend that you connect a pressure tank to the outlet side of the pump to maintain a suitable pressure at the tapping point.

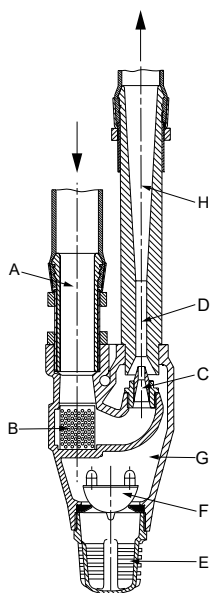

Sectional drawing of an ejector

Water is pumped through the pressure pipe (A) and the strainer (B) to the nozzle (C). The water passes the nozzle at high speed and flows into the diffuser (D). Via the strainer (E) and bottom valve (F), water to be pumped up is in connection with the chamber (G).

From the chamber, it is pressed into the diffuser (D) by the water jet from the nozzle (C). There, the two water flows mix, and the velocity is converted into pressure, driving the water up through the riser pipe (H) to the inlet port of the pump.

Technical data

Maximum system pressure	16 bar
Maximum ambient temperature	40 °C
Maximum liquid temperature	40 °C
Minimum size of borehole	3"

Pump range

The following deep-well pumps are available with an ejector:

Pump type	CR	CRI	CRN
1s, 1, 3			
5	•	•	
10, 15, 20			
32, 45, 64			
95, 125, 155			
185, 215, 255			

- Available

Use of inlet pipe

If the well capacity is lower than the pump capacity, dry running of the pump can be prevented by fitting an inlet pipe below the ejector. To enable this, the ejector strainer (E) is replaced with a special threaded nipple.

Performance curves and technical data

For information about the performance curves and technical data of CR deep-well pumps, see the sections on CR deep-well and CR deep-well pumps.

Ejectors

Based on the performance curves in the section on CR deep-well, we offer the following ejectors:

Ejector type	Product number
45B	90230045
44B	90230044
29B	90230029
22B	90230022
20B	90230020
11B	90230011

Contact Grundfos for further information about CR, CRI ejector pumps.

Related information

- [CR deep-well](#)
- [CR deep-well pumps](#)

TM032954

TM032953

Pump rubber parts

We offer pumps with a wide range of customized rubber materials such as EPDM, FKM, FFKM, FXM and CR to suit your requirements.

Pump type	Rubber material				
	EPDM	FKM	FFKM	FXM	CR ¹⁷⁾
CR, CRI, CRN 1s, 1, 3, 5	•	•	•	•	•
CR, CRI, CRN 10, 15, 20	•	•	•	•	•
CR, CRN 32, 45, 64	•	•	• ¹⁸⁾	•	-
CR, CRN 95, 125, 155	•	•	• ¹⁸⁾	•	-
CR, CRN 185, 215, 255	•	•			

¹⁷⁾ Only available for CRN MAGDrive pumps

¹⁸⁾ These pumps are fitted with FXM sleeve gaskets. All other rubber parts are of FFKM.

- Available

We offer customized rubber materials for the following pump types:

Pump type	CR	CRI	CRN
1s, 1, 3, 5	•	•	•
10, 15, 20	•	•	•
32, 45, 64	•		•
95, 125, 155	•		•
185, 215, 255			

- Available

Bearing flange

To ensure a long pump life and reliable operation, fit a bearing flange between the motor and the pump head.

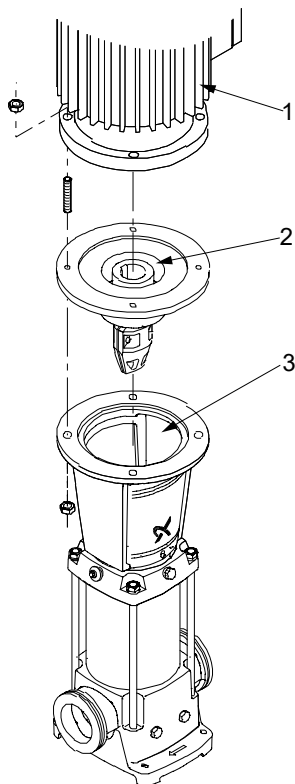

TM034062

Bearing flange

Key

Pos.	Designation
1	Motor
2	Bearing flange
3	Pump head

A bearing flange is an additional flange with an oversize ball bearing to absorb axial forces in both directions. The coupling is part of the bearing flange fitted to obtain optimum alignment.

Note that the bearing flange requires a motor with keyway and ball bearings according to IEC 34 and NEMA.

A bearing flange is used in two situations:

1. A standard motor with standard ball bearing is required. The bearing flange absorbs the hydraulic load from the pump, ensuring an acceptable motor bearing life.
2. The pump is to run at a higher inlet pressure than the maximum pressure recommended.

Bearing lubrication

Pump type with bearing flange	Bearing type	
	Life-time greased	Re-greasable ¹⁹⁾
Motor power [kW]		
CR, CRI, CRN 1s-5	≤ 7.5	-
CR, CRI, CRN 10-20	≤ 4	≥ 5.5
CR, CRN 32-64	≤ 4	≥ 5.5
CR, CRN 95-255	-	≥ 5.5

¹⁹⁾ Re-greasable bearing flanges are equipped with grease nipples and must be lubricated regularly. Follow the instructions on the bearing flange.

Bearing flanges with re-greasable bearings cannot be ATEX-approved.

Pump range

The following pump types are available with bearing flange:

Pump type	CR	CRI	CRN
1s, 1, 3, 5	•	•	•
10, 15, 20	•	•	•
32, 45, 64	•		•
95, 125, 155	•		•
185, 215, 255	•		•

• Available

Bearing flange for CR pumps

CR, CRI, CRN 1s, 1, 3, 5 (≤ 7.5 kW) CR, CRI, CRN 10, 15, 20 (≤ 4 kW)

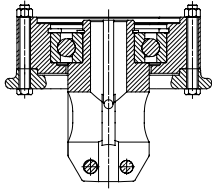

TM027436

CR, CRI, CRN 10, 15, 20 (≥ 5.5 kW)

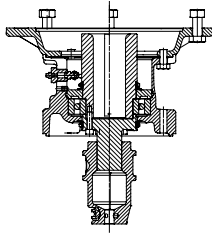

TM027437

CR, CRN 32, 45, 64 (≤ 4 kW)

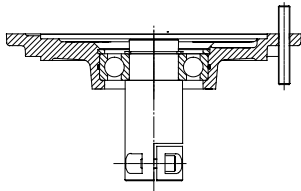

TM014352

CR, CRN 32, 45, 64 (≥ 5.5 kW)

CR, CRN 95, 125, 155, 185, 215, 255

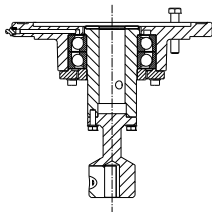

TM073754

Additional height of bearing flange

The following additional heights in millimetres must be added to the total height of the pump.

CR, CRI, CRN 1s, 1, 3, 5, 10, 15, 20

Motor power	Additional height
IEC [kW]	
0.37 - 0.55	31
0.75 - 1.1	32
1.5 - 4.0	40
5.5 - 7.5	23 ²⁰⁾ /150 ²¹⁾
11.0 - 18.5	180
NEMA [HP]	
0.33 - 2.0	40
3-10	45
15-40	135

²⁰⁾ CR, CRI, CRN 1s, 1, 3, 5

²¹⁾ CR, CRI, CRN 10, 15, 20

CR, CRN 32, 45, 64 (≤ 4 kW)

Motor power	Additional height
IEC [kW]	
3 - 4	23
NEMA [HP]	
3-10	22

CR, CRN 32, 45, 64 (≥ 5.5 kW)

CR, CRN 95, 125, 155, 185, 215, 255

Motor power	Additional height
IEC [kW]	
5.5 - 45	21
55-200	25
NEMA [HP]	
15-75	21
100-300	25

For information about the total height of a given CR pump, see the relevant data booklets available at the Grundfos Product Center.

Related information

[Further documentation](#)

Support bearings

We offer customized pumps with support bearings of bronze for corrosive applications for the following pump types:

• Available.

Pump type	CR	CRI	CRN
1s, 1, 3, 5			
10, 15, 20			
32, 45, 64	•		•
95, 125, 155	•		•
185, 215, 255			

• Available

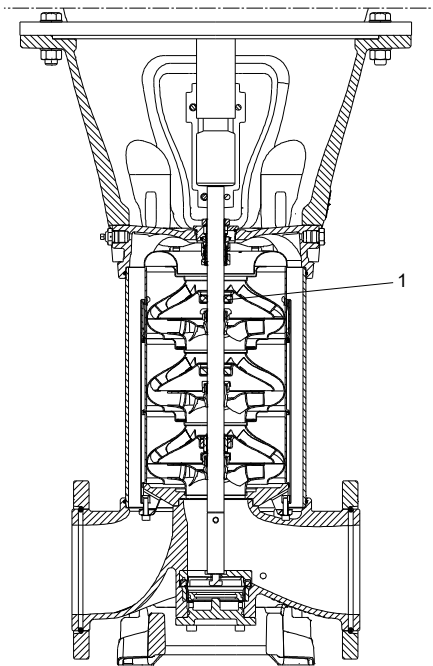

Placement of the support bearings on a CR pump

Pos.	Description
1	Support bearing

Bearing material

We offer pumps with a wide range of customized bearing materials such as bronze, tungsten carbide and carbon-filled PTFE to suit your requirements.

Pump size	Bearing material
CR, CRN 1, 3, 5, 10, 15, 20	Bronze/tungsten carbide Graflon/tungsten carbide
CR, CRN 32, 45, 64	Tungsten carbide/tungsten carbide
CR, CRN 95, 125, 155	Silicon carbide/silicon carbide

We offer customized bearing materials for the following pump types:

Pump type	CR	CRI	CRN
1s, 1, 3, 5	•	•	•
10, 15, 20	•	•	•
32, 45, 64	•		•
95, 125, 155	•		•
185, 215, 255			

Pump head positions

As standard, the pump head is mounted so that the vent screw is in line with the outlet port.

The pump head can be mounted in three other positions in steps of 90°.

Note that the vent of horizontal pumps must always point upwards.

Customized nameplate

We offer additional customized nameplates attached to the pump:

- a nameplate supplied by you
- a Grundfos nameplate customized in terms of a specific duty point
- a Grundfos nameplate with a tag number.

A Grundfos standard nameplate is always fitted on the pump.

Dry-running protection

LiqTec



LiqTec dry-running protection device

Grundfos LiqTec immediately cuts off the pilot current to the motor protection relay in the following cases:

- There is no liquid in the pump.
- The liquid temperature exceeds $130 \pm 5 \text{ }^\circ\text{C}$.
- The sensor, sensor cable, electronic unit or power supply fails.

When connected to the PTC sensors in the motor, LiqTec also protects the motor against overheating.

The sensor is easily inserted through the 1/2-inch connection in the pump head close to the shaft seal. It can, however, also be used externally.

LiqTec sends a heat impulse through the sensor, measuring the temperature of the sensor. Liquid in the pump cools the sensor as well as the shaft seal and other pump parts.

If there is no liquid present, LiqTec detects a high temperature in the sensor and turns off the pump motor immediately to prevent damage. LiqTec also prevents excessive liquid temperatures from damaging the pump. If LiqTec senses a liquid temperature above $130 \text{ }^\circ\text{C}$, it turns off the pump motor immediately. LiqTec is a fail-safe device, meaning that the pump stops as soon as the sensor detects an error in the sensor cable or the electronics, or if the power supply of the control unit is switched off.

Restarting the pump can be automatic or manual when the sensor detects liquid in the pump again.

Remote restarting is possible via digital input.

The electronic control unit can also be connected to the PTC sensor measuring the motor temperature. In case of overheating of the motor, the system turns off the pump motor.

For installation examples, see sections about connection to standard and MGE motors.

Related information

[Connection to standard motors](#)

[Connection to MGE motors \(0.37 - 2.2 kW\)](#)

[Connection to MGE motors \(3-26 kW\)](#)

Connection to standard motors

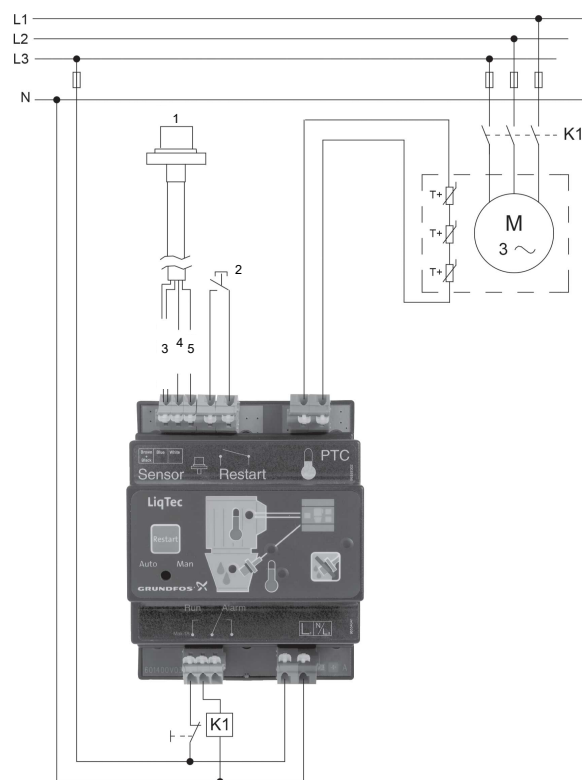

LiqTec connected to a standard motor

GR9415

TM030112

Connection to MGE motors (0.37 - 2.2 kW)

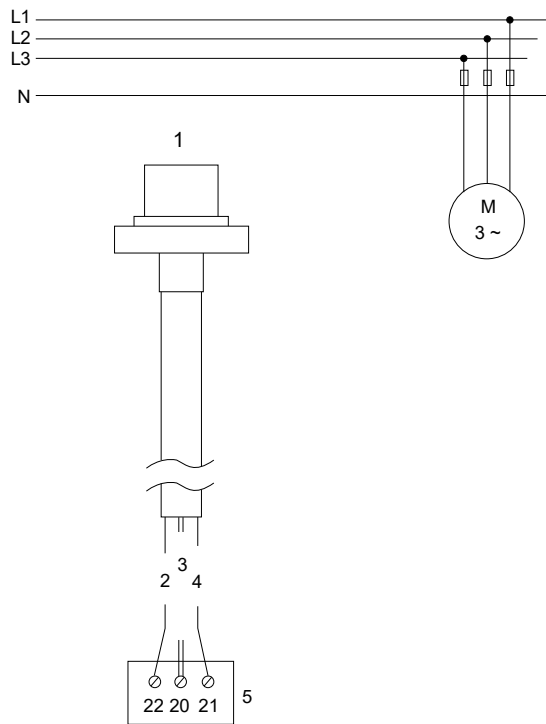

LiqTec connected to an MGE motor (0.37 - 2.2 kW)

Pos.	Description
1	Sensor
2	Blue
3	Brown/black
4	White
5	Terminals in MGE motor

TM060807

Connection to MGE motors (3-26 kW)

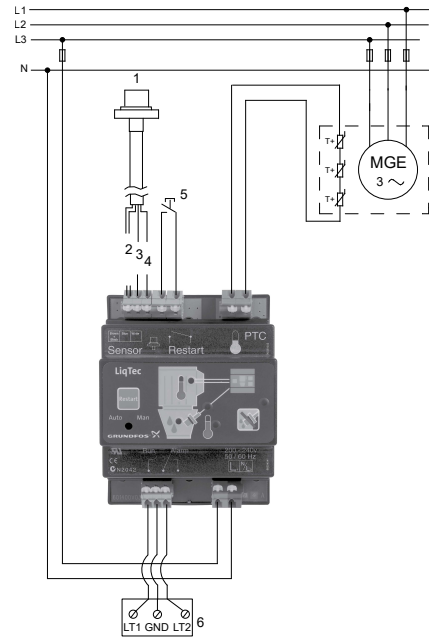

LiqTec connected to an MGE motor (3-26 kW)

Pos.	Description
1	Sensor
2	Brown/black
3	Blue
4	White
5	External restart
6	Terminals in MGE motor

Dimensions

116 x 90 mm.

LiqTec can be mounted on a DIN rail in a control cabinet.

Technical data

Supply voltage	1 x 80-130 V or 1 x 200-240 V
Power consumption	5 W
Max. pressure	40 bar
Min./max. liquid temperature	-20 °C / +120 °C
Max. ambient temperature	50 °C
Humidity	99 %
Enclosure class	IPX0
Pumped liquid	Any water-based liquid handled by Grundfos pumps
Cable length	5 m ²²⁾

22) 15-metre cable is available on request.

TM044472

Pipe connections

TriClamp connection

A base with TriClamp connection is of hygienic design with a sanitary coupling for use in the pharmaceutical, food and beverage industry. The connection is in accordance with EN/DIN 32676.

Dimensions

All dimensions are in millimetres.

A set consists of one clamping ring, one gasket and one pipe stub. The clamping ring is made of stainless steel EN/DIN 1.4301/AISI 304. The port is made of stainless steel EN/DIN 1.4401/AISI 316. The gasket is made of PTFE or EPDM.

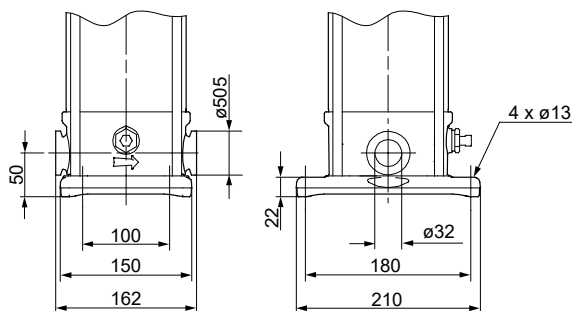

TM034648

TriClamp connection for CRI, CRN 1s, 1, 3 and 5

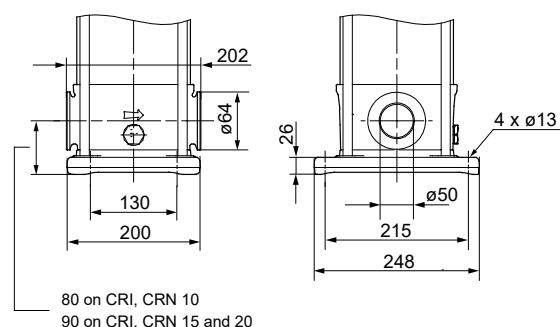

TM034649

TriClamp connection for CRI, CRN 10, 15 and 20

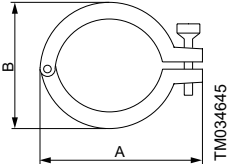
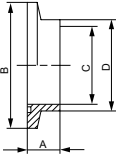
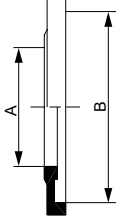
Connection	Clamping ring	Port	Gasket						
 GR5840	 TM034645		 TM034647						
Pump type	PN	A	B	A	B	C	D	A	B
CRI, CRIE, CRN, CRNE 1s, 1, 3, 5	16	92.0	59.5	21.5	50.5	35.6	38.6	35.3	50.5
	50	102.0	60.0		32.0	36.0	32.2		
CRI, CRIE, CRN, CRNE 10, 15, 20	16	104.4	74.0	21.5	64.0	48.6	51.6	48.0	64.0
	50	123.0	75.0		65.0	50.0	54.0	50.2	

Pump type	Pipe connection	Connection material	Gaskets	Pressure [bar]	Coupling sets required	Product number
CRI, CRIE, CRN, CRNE 1, 3, 5	DN 32	Stainless steel	PTFE	16	2	96515375
			EPDM		2	96515374
CRI, CRIE, CRN, CRNE 10, 15, 20	DN 50		PTFE	16	2	96515377
			EPDM		2	96515376
				50	2	97549397

We offer TriClamp connections for the following pump types:

Pump type	CR	CRI	CRN
1s, 1, 3, 5		•	•
10, 15, 20		•	•
32, 45, 64			
95, 125, 155			
185, 215, 255			

- Available

Related information

[Further documentation](#)

FlexiClamp according to EN/DIN 11851

A base with connections according to EN/DIN 11851 is of hygienic design for use in the dairy, food and beverage industries.

A set consists of one pipe stub with external thread designed for a FlexiClamp base with union connection.

Dimensions

All dimensions are in millimetres.

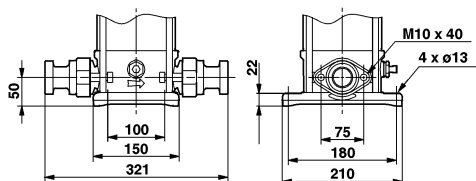

TM034682

Connection to EN/DIN 11851 for CRI, CRN 1s, 1, 3 and 5

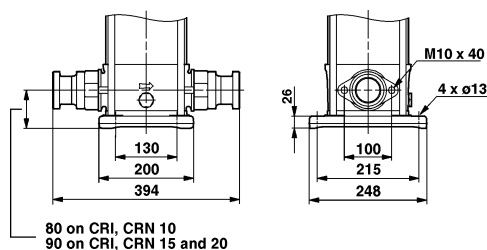

TM034683

Connection to EN/DIN 11851 for CRI, CRN 10, 15 and 20

Pump type	Pipe connection	Connection material	Gaskets	Pressure [bar]	Coupling sets required	Product number
CRI, CRIE, CRN, CRNE 1, 3, 5	DN 32	Stainless steel	EPDM	16	2	96551545
			FKM		2	96551547
CRI, CRIE, CRN, CRNE 10, 15, 20	DN 50		EPDM		2	96551549
			FKM		2	96551570

We offer the above connections for the following pump types:

Pump type	CR	CRI	CRN
1s, 1, 3, 5			•
10, 15, 20			•
32, 45, 64			
95, 125, 155			
185, 215, 255			

- Available

Collar connection (aseptic)

A base with connections according to EN/DIN 11853-2 is of non-sanitary design but is often used in the dairy, food, beverage and pharmaceutical industries. The collar connection is not approved for process use. Instead, it is used in secondary systems such as washing and cleaning, CIP cleaning and steam applications.

Dimensions

All dimensions are in millimetres.

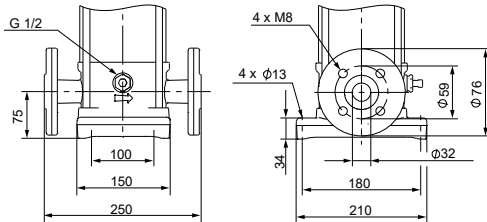

Collar connection for CRI, CRN 1s, 1, 3 and 5

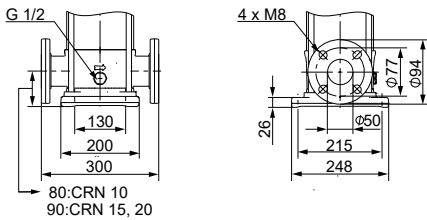

Collar connection for CRI, CRN 10, 15 and 20

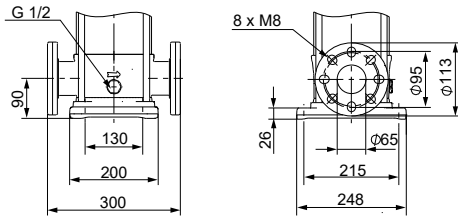

Collar connection for CRI, CRN 15 and 20

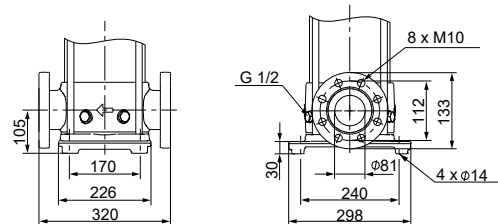

Collar connection for CRI, CRN 32

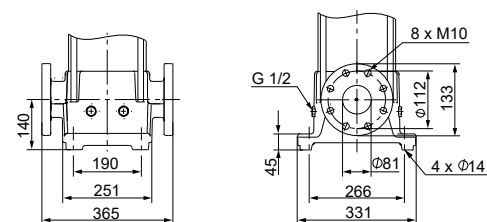

Collar connection for CRI, CRN 45

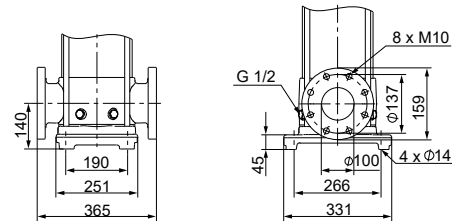

Collar connection for CRI, CRN 64

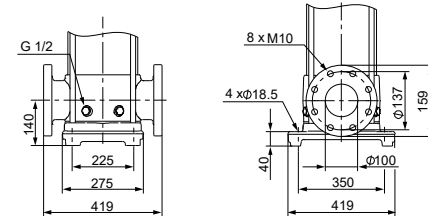

Collar connection for CRN 95

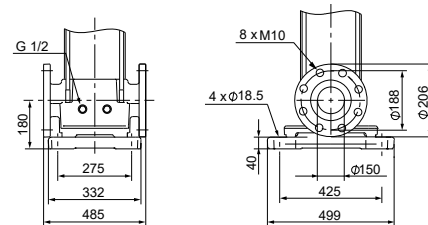

Collar connection for CRN 125 and 155

Pump type	Pipe connection ²³⁾	Pressure rating
CRN, CRNE 1s, 1, 3, 5	DN 32	PN 25
CRN, CRNE 10, 15, 20	DN 50	PN 16
CRN, CRNE 15, 20	DN 65	PN 16
CRN, CRNE 32, 45	DN 80	PN 16
CRN, CRNE 64, 95	DN 100	PN 16
CRN, CRNE 125, 155	DN 15	PN 10

²³⁾ Connection material: Stainless steel

We offer the above connections for the following pump types:

Pump type	CR	CRI	CRN
1s, 1, 3, 5			•
10, 15, 20			•
32, 45, 64			•
95, 125, 155			•
185, 215, 255			•

• Available

TM056274

TM056269

TM073761

TM056270

TM073760

TM056271

TM056272

TM056273

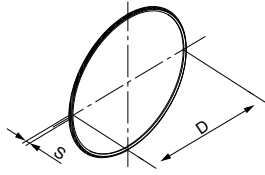
Dimensions of an O-ring

TM056242

DN	Inner diameter (D) [mm]	Thickness (S) [mm]
32	34	5
50	52	5
65	68	5
80	83	5
100	102	5
150	158	7

PJE coupling

A base with PJE couplings is designed for use in a wide range of industrial applications.

A set consists of two coupling halves, one gasket, one coupling liner for welding and bolts and nuts.

Dimensions

All dimensions are in millimetres.

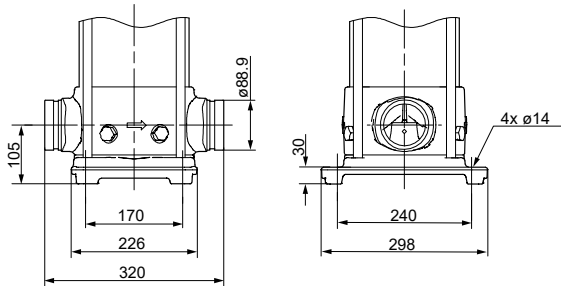

PJE coupling for CRN 32

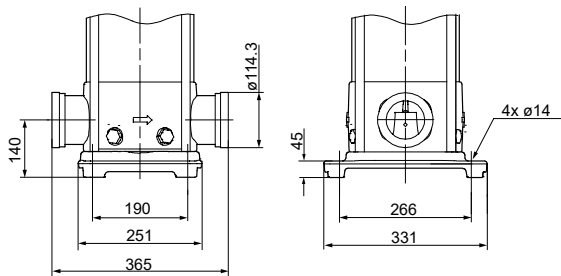

PJE coupling for CRN 45

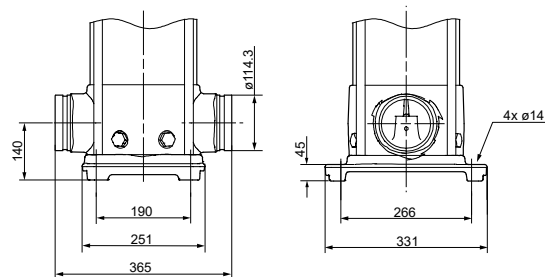

PJE coupling for CRN 64

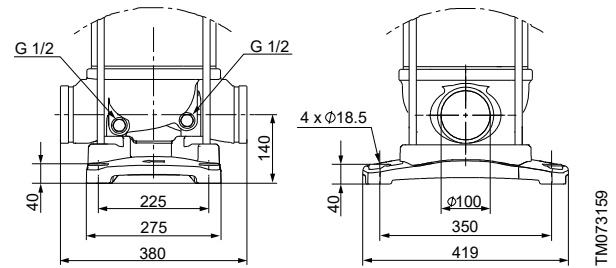

PJE coupling for CRN 95

TM034719

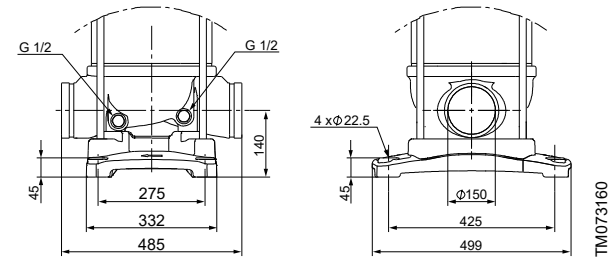

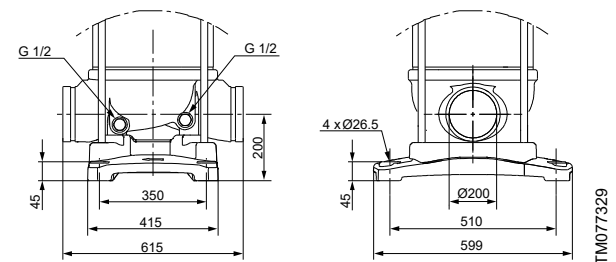

PJE coupling for CRN 125 and 155

TM034720



PJE coupling for CRN 185, 215, 255

TM034721

Part	Designation	Designed for pump type	Rubber parts	Product number
 TM003712	Victaulic type 77 coupling 3": Ø89 4": Ø114	CRN 32	NBR seal 3"	00ID7664
		CRN 45, 64, 95	NBR seal 4"	96415463
 TM003709	Victaulic coupling liner for welding	CRN 32	N version 3"	00150574
		CRN 45, 64, 95	N version 4"	96416743

We offer PJE couplings with NBR rubber parts for the following pump types:

Pump type	CR, CRE	CRI, CRIE	CRN, CRNE
1s, 1, 3, 5			
10, 15, 20			
32, 45, 64, 95			•
125, 155			
185, 215, 255			

- Available

As standard, PJE connections are available with EPDM and FKM rubber parts on CRI, CRN, 1s to 255 pumps.

ANSI or JIS connection

CR pumps with ANSI or JIS connection

We offer pumps with ANSI or JIS flanges for the following pump types:

Pump type	CR	CRI	CRN
1s, 1, 3, 5 ²⁴⁾			
10 ²⁴⁾			
15, 20	•	•	•
32, 45, 64	•		•
95, 125, 155	•		•
185, 215, 255	•		•

²⁴⁾As standard, CR, CRE, CRI, CRIE, CRN, CRNE 1s, 1, 3, 5 and 10 pumps are available with connections that meet the requirements of ANSI, DIN and JIS.

- Available

Technical data

Connection	Max. rated pressure
ANSI	Class 300
JIS	30 K

The dimensions of pumps with DIN, ANSI or JIS flanges are the same, apart from the flange bolt holes.

Customized connections

We offer a wide range of customized connections for the following pump types:

Pump type	CR	CRI	CRN
1s, 1, 3, 5	•	•	•
10, 15, 20	•	•	•
32, 45, 64, 95	•		•
125, 155			
185, 215, 255			

Contact Grundfos for further information about customized connections.

We also offer the following connections:

- oval flanges (BSP)
- DIN flanges
- PJE couplings (Victaulic®) for CRN(E)
- clamp couplings (L-couplings)
- unions (+GF+).

For further information about connections, see the relevant data booklets available at the Grundfos Product Center.

Base plate for CR 95 with CR 90 footprint

It is possible to use a CR 95 pump to replace a CR 90 pump and still have the same footprint.

A special base plate with the same small footprint as the CR 90 pump is available for CR 95 pumps up to and including 55 kW. The material is ductile cast iron EN-GJS-500-7.

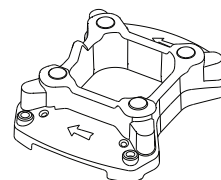

TM072495

Base plate for CR 95 with a small CR 90 footprint

9. Certificates

CR pumps with certificates

We offer certificates for a number of applications requiring documentation on the pump quality. Examples are:

- pharmaceutical industry
- maritime and offshore applications
- potentially explosive environments
- energy and power suppliers.

Note that the certificates must be ordered with the pump.

The following pumps are available with certificates:

Pump type	CR	CRI	CRN
1s, 1, 3, 5	•	•	•
10, 15, 20	•	•	•
32, 45, 64	•		•
95, 125, 155	•		•
185, 215, 255	•		•

- Available

Certificates

Certificate	Description
Certificate of compliance with the order	According to EN 10204, 2.1, this Grundfos document certifies that the pump supplied is in compliance with the order specifications.
Test certificate, non-specific inspection and testing	According to EN 10204, 2.2, it is a certificate with inspection and test results of a non-specific pump.
Inspection certificate 3.1	It is a Grundfos document certifying that the pump supplied is in compliance with the order specifications. Inspection and test results are mentioned in the certificate.
Inspection certificate	Grundfos document certifying that the pump supplied is in compliance with the order specifications. Inspection and test results are mentioned in the certificate. Certificate from the surveyor is included. We offer the following inspection certificates: <ul style="list-style-type: none"> • Lloyds Register of Shipping (LRS) • Det Norske Veritas and Germanischer Lloyd (DNV-GL) • Bureau Veritas (BV) • American Bureau of Shipping (ABS) • Registro Italiano Navale Agenture (RINA) • China Classification Society (CCS) • Biro Klassifikasio Indonesia (BKl) • United States Coast Guard (USCG) • Nippon Kaiji Koykai (NKK) • Korea Register of Shipping (KR) • Polski Rejestr Statkow (PRS) • Vietnam Register (VR) • Indian Register of Shipping (ERS) • China corporation registre of shipping (CR).
Standard test report	It certifies that the main components of the specific pump are manufactured by Grundfos, and that the pump has been QH-tested, inspected and conforms to the full requirements of the appropriate catalogues, drawings and specifications.
Material specification report	It certifies the material used for the main components of the specific pump.
Material specification report with certificate from raw material supplier	It certifies the material used for the main components of the specific pump. A material specification report with EN 10204 material certificate from the raw material supplier will be supplied for each main component.
Duty-point verification report	It certifies a test point specified by the customer. Issued according to ISO 9906 concerning Duty point verification grades 3B, 2B and 1B.
Surface-roughness	It shows the measured roughness of the cast pump base of the specific pump. The report indicates the values measured at the base inlet and outlet according to ISO 1302.
Vibration report	The vibration report indicates the values measured during the performance test of the specific pump according to ISO 10816.
Motor test report	It shows the performance test of the specific motor, including power output, current, temperature, stator windings resistance and insulation test.
Cleaned and dried pump	It confirms that the specific pump has been cleaned and dried, and how it was done.
PWIS-free pump	PWIS means Paint-Wetting Impairment Substances. The term is used to describe substances that inhibit or destroy the ability of paint to adhere to surfaces.
Statement Regulation EC 1935/2004	It complies with the Food Contact Materials Regulation.
Positive Material identification (PMI report EN 10204 3.2)	It confirms that the material types of the listed pump components have been verified by testing.
Vacuum-dried pump	It confirms that the specific pump has been vacuum-dried, and how it was done.

Certificate	Description
Electropolished pump	It confirms that the specific pump has been electropolished. The maximum surface roughness is specified in the report.
ATEX-approved pump	It confirms that the specific pump is ATEX-approved according to the EU directive 94/9/EC, the ATEX directive.
Motor routine test	It certifies that the materials and parts for MG, MGE motors are manufactured by Grundfos, and that the motor has been tested, inspected and it conforms to the full requirements of the appropriate catalogues, drawings and specifications.

See examples of the certificates below.

Note that other certificates are available on request.

Examples of certificates

Certificate of compliance with the order

be think innovate **GRUNDFOS**

Certificate of compliance with the order

EN 10204 2.1

General info	
Customer name	
Customer order no.	
Customer TAG no.	GRUNDFOS order no.
GRUNDFOS order no.	
Product type	

We the undersigned hereby guarantee and certify that the materials and/or parts for the above mentioned product were manufactured, tested, inspected, and conform to the full requirements of the appropriate catalogues, drawings and/or specifications relative thereto.

GRUNDFOS
Date: _____
Signature: _____
Name: _____
Dept.: _____

Part no. 96507895/PMU/000/1223711

TM034165

Test certificate

be think innovate **GRUNDFOS**

Test Certificate

Non-specific inspection and testing

EN 10204 2.2

Customer name	
Customer name	
Customer order no.	
Customer TAG no.	
GRUNDFOS order no.	

Pump		Part Number
Pump type		Part Number
Motor Make		
Flow	m ³ /h	
Head	m	
Max. operating pressure	bar	
Max. operating temperature	°C	
Power P2	kW	
Voltage	V	
Frequency	Hz	
Full load current	A	
Motor speed	min ⁻¹	

We the undersigned hereby guarantee and certify that the materials and/or parts for the above mentioned product were manufactured, tested, inspected, and conform to the full requirements of the appropriate catalogues, drawings and/or specifications relative thereto.

GRUNDFOS
Date: _____
Signature: _____
Name: _____
Dept.: _____

*1) Cleaned and dried pumps and PWIS free pumps are not performance tested

Part no. 96507896/PMU/000/1223711

TM034163

Inspection certificate 3.1

Inspection Certificate

Type EN 10204 3.1

General info	
Customer name	
Customer order no.	GRUNDFOS order no.
Customer TAG no.	
Ship / new building	
Shipyard / factory	

Pump		Motor	
Pump type	Make	Part No.	Part No.
Part No.	Serial No.	Part No.	Serial No.
Model	P2 [kW]	Voltage [V]	Current [A]
Flow rate [m ³ /h]	Head [m]	Motor speed [min ⁻¹]	Frequency [Hz]
Max. liquid temp [°C]	Max. opr. Press. [bar]	IP code	Max. temp. amb. [°C]

Required duty point	
Flow rate [m ³ /h]	Head [m]

Result of tests are attached. See test point

GRUNDFOS
Date: _____
Signature: _____
Name: _____
Dept.: _____

be think innovate **GRUNDFOS**

Part no. 96507897/PMU/000/1252874

TM060200

Inspection certificate

Inspection Certificate

Russian Maritime Register of Shipping

General info	
Customer name	
Customer order no.	GRUNDFOS order no.
Customer TAG no.	Certificate No.
Ship / new building	
Shipyard / factory	

Pump		Motor	
Pump type	Make	Part No.	Part No.
Part No.	Serial No.	Part No.	Serial No.
Model	P2 [kW]	Voltage [V]	Current [A]
Flow rate [m ³ /h]	Head [m]	Motor speed [min ⁻¹]	Frequency [Hz]
Max. liquid temp [°C]	Max. opr. Press. [bar]	IP code	Max. temp. amb. [°C]
Stamping ID			

Part according to EN 10204 - 3.1				
Part	Raw material Grundfos PN	Raw material grade and standard	Vendor	Heat / Charge No.
Pump head				
Pump head cover*				
Base				
Sleeve				
Pump head**				
Seal chamber**				
THD flange***				
Blind cover (THD)****				

* Only for CRI(N) Back to Back, Tandem, Air cooled top
** Only for CRI(N) Magliner "Pump head cover" removed and "Pump head" included
*** Only for CRI(N) 85, 125, 155, 185, 215, 255 with base prepared for THD
**** Only for CRI(N) 85, 125, 155, 185, 215, 255 with base prepared for THD

Part according to EN 10204 - 2.2		
Part	Material type	Raw material grade acc. to standard
Shaft		
Impeller		
Chamber		

Operational function	
Media	Application

Required duty point	
Flow rate [m ³ /h]	Head [m]

Result of tests are attached. See test point

Declaration of compliance for the Class Society Rules
Rules for technical supervision during construction of ships and manufacture of materials and products for ships, Part IV

GRUNDFOS
Date: _____
Signature: _____
Name: _____
Dept.: _____

be think innovate **GRUNDFOS**

Part no. 96507925/PMU/000/1249889

TM034156

Standard test report

Test Report - Performance curve
ISO 9906:2012 Grade 3B

General Info			
Customer name			
Customer order no.			
Customer TAG no.			
GRUNDFOS order no.			
Pump type	Part number		
Serial number	Model		

We the undersigned hereby guarantee and certify that the materials and/or parts for the above mentioned product were manufactured by GRUNDFOS, tested, inspected, and conform to the full requirements of the appropriate catalogues, drawings and/or specifications relative thereto.

The attached test result is from the above mentioned pump.

GRUNDFOS
Date: _____
Signature:
Name: _____
Dept.: _____

GRUNDFOS
Date: _____
Signature:
Name: _____
Dept.: _____

be think innovate **GRUNDFOS**
Part no. 96507930/PMI/000/125007

TM034143

Material specification report

Material specification report
Type EN 10204 - 2.2

General Info			
Customer name			
Customer order no.			
Customer TAG no.			
GRUNDFOS order no.			
Pump type	Part number		
Serial number	Model		

Part	Material	Standard

We the undersigned hereby guarantee and certify that the materials and/or parts for the above mentioned product were manufactured, tested, inspected, and conform to the full requirements of the appropriate catalogues, drawings and/or specifications relative thereto.

GRUNDFOS
Date: _____
Signature:
Name: _____
Dept.: _____

GRUNDFOS
Date: _____
Signature:
Name: _____
Dept.: _____

be think innovate **GRUNDFOS**
Part no. 96507928/PMI/000/1253903

TM034150

Material specification report with certificate from raw material supplier

Material specification report
Type EN 10204 - 3.1/2.2

General Info			
Customer name			
Customer order no.			
Customer TAG no.			
GRUNDFOS order no.			
Pump type	Part number		
Serial number	Model		

Part according to EN 10204 - 3.1				
Part	Raw material Grundfos PN	Raw material grade and standard	Vendor	Heat / Charge No.
Pump head				
Pump head cover*				
Base				
Sleeve				
Pump head**				
Seal chamber**				
THD flange***				
Blind cover (THD)***				

*] Only for CR(I/N) MagDrive ("Pump head cover" removed and "Pump head" included)
**] Only for CR(I/N) Back to Back, Tandem, Air cooled top
***] Only for CR(N) 95, 125, 155, 185, 215, 255 with base prepared for THD

Part according to EN 10204 - 2.2		
Part	Material type	Raw material grade acc. to standard
Shaft		
Impeller		
Chamber		

We the undersigned hereby guarantee and certify that the materials and/or parts for the above mentioned product were manufactured, tested, inspected, and conform to the full requirements of the appropriate catalogues, drawings and/or specifications relative thereto.

GRUNDFOS
Date: _____
Signature:
Name: _____
Dept.: _____

GRUNDFOS
Date: _____
Signature:
Name: _____
Dept.: _____

be think innovate **GRUNDFOS**
Part no. 96507929/PMI/000/1249525

TM060753

Duty point verification report

Test Report - Duty point verification
ISO 9906:2012 Grade 3B, Q&H

General Info			
Customer name			
Customer order no.			
Customer TAG no.			
GRUNDFOS order no.			
Pump type	Part number		
Serial number	Model		

We the undersigned hereby guarantee and certify that the materials and/or parts for the above mentioned product were manufactured by GRUNDFOS, tested, inspected, and conform to the full requirements of the appropriate catalogues, drawings and/or specifications relative thereto.

The attached test result is from the above mentioned pump.

GRUNDFOS
Date: _____
Signature:
Name: _____
Dept.: _____

GRUNDFOS
Date: _____
Signature:
Name: _____
Dept.: _____

be think innovate **GRUNDFOS**
Part no. 96539699/PMI/000/125007

TM034148

PWIS free pump

Certificate

Pump with no paint wetting impairment substances (PWIS)

General info			
Customer name			
Customer order no.			
Customer TAG no.			
GRUNDFOS order no.			
Pump type	Part number		
Serial number	Model		

We the undersigned hereby confirm that the above-mentioned product is manufactured according to specifications mentioned below:

- All components of the pump including shaft seal, motor, rubber materials for shaft seals, do not contain PWIS, or release PWIS.
- Consumables, like oil, grease, soap water etc, without containing PWIS are used for assembly.
- Tools for assembling of the products are not containing any paint wetting impairment substances.
- The product is not performance tested.
- Finished product is wrapped in special PWIS free plastic bag before being packed for shipment

GRUNDFOS
Date: _____
Signature:
Name:
Dept.:

be think innovate **GRUNDFOS**
Part no. 98598005/PMI/000/1251303

TM073998

Statement regulation EC 1935/2004

Statement

Regulation (EC) 1935/2004

General info			
Customer name			
Customer order no.			
Customer TAG no.			
GRUNDFOS order no.			
Pump type	Part number		
Serial number	Model		

Statement

For pumps with EPDM
The pumps have been successfully tested for contact at a maximum of 120°C for a maximum of 5 minutes with:

- aqueous foodstuffs with a pH above 4.5
- alcohol containing foodstuffs with an alcohol content of a maximum 50%
- milk-related foodstuffs, with NO free fats on the surface (e.g. milk and milk based drinks whole, partly dried and skimmed or partly skimmed)

Please be aware that the above mentioned pump is not a sanitary pump, and that remains from machining may be present inside the pump, why appropriate precautions should be taken.

The above mentioned pump manufactured by Grundfos contain various materials that have all been evaluated in relation to contact with foodstuffs.

Plastic parts are manufactured according to Regulation (EU) No. 10/2011 as amended by up to and including Regulation (EU) No. 2016/1416/EC. All substances used for the plastic parts are listed in Annex I. The plastic parts do not contain any dual use additives. Overall migration tests have been conducted on the plastic parts. The results of the overall migration tests comply with the limit of 10 mg/dm².

Rubber parts are manufactured according to ResAP (2004) 4 on Rubber Products Intended to come into Contact with Foodstuffs or the German BfR recommendation XXI on Commodities based on Natural and Synthetic Rubber.

Silicone parts are manufactured according to ResAP (2004) 5 on Silicones to be used for Food Contact or the German BfR recommendation XV on Silicones.

The chemical composition of the metal parts is known and recognised by Grundfos. The metal parts do not release metals or heavy metals in quantities that may endanger human health when tested as described in CM/Res(2013)9 from EDQM.

Substances restricted by specific migration limits are present in the polymer parts. These limits are all compiled with. Substances listed in Annex XIV on Substances of Very High Concern of Regulation (EC) No. 1907/2006 are not present in the products.

The products are manufactured according to Regulation (EC) No. 2023/2006 on Good Manufacturing Practice.

be think innovate **GRUNDFOS**
Part no. 98981818/PMI/000/1251003

TM073999

**Positive Material Identification
(PMI report EN 10204 3.2)**

Report

Positive Material Identification
Type EN 10204- 3.2

General info			
Customer name			
Customer order no.			
Customer TAG no.			
GRUNDFOS order no.			
Pump type	Part number		
Serial number	Model		

Type	Company Name	PMI Report ID

We the undersigned hereby certify that listed parts and materials used for above mentioned product has been tested and inspected according to conditions described in appendix together with PMI test results.
Note: For sheeted components consisting of several sub-components only the main sub-component is measured and included in this report.

GRUNDFOS
Date: _____
Signature:
Name:
Dept.:

be think innovate **GRUNDFOS**
Part no. 99277139/PMI/000/1251303

TM074004

Surface-roughness

Report – Surface roughness

According to ISO 1302

General info			
Customer name			
Customer order no.			
Customer TAG no.			
GRUNDFOS order no.			
Pump type	Part number		
Serial number	Model		
Base part number			

The surface roughness is measured as the maximum roughness of the inlet and outlet surface of the base.

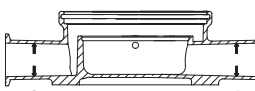

Surface Treatment	Roughness value RA (µm)	Roughness degree
None	50	N 12
Electro-polished	25	N 11
	12.5	N 10
	6.3	N 9
	3.2	N 8
	1.6	N 7
	0.8	N 6
	0.4	N 5
	0.2	N 4
	0.1	N 3
	0.05	N 2
	0.025	N 1

Measured values A		
R _{max}	(µm)	
R _A	(µm)	
R _Z	(µm)	

Measured values B		
R _{max}	(µm)	
R _A	(µm)	
R _Z	(µm)	

GRUNDFOS
Date: _____
Signature:
Name:
Dept.:

be think innovate **GRUNDFOS**
Part no. 96507931/PMI/000/1252874

TM034147

Vibration report

Vibration report

According to ISO 20816-1 / ISO 10816-7

General info	
Customer name	
Customer order no.	
Customer TAG no.	
GRUNDFOS order no.	
Pump type	Part number
Serial number	Model

Test Conditions: The pump is floor mounted on a steel plate supported by Sylomer foam. For vibration measurement positions see Figure.

P2 [kW]	Voltage [V]
Frequency [Hz]	Number of Poles
Flow rate [m ³ /h]	Head [m]
Remarks:	

Result of Measurement:

Position	RMS vibration Velocity (mm/s)
1	
2	
3	
4	
5	
6	
7	
8	
9	

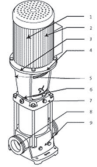

Typical Zone boundary - ISO 20816-1:

Vel. (mm/s)	Range of typical zone boundary values for non-rotating parts.
0,28	
0,45	
0,71	
1,12	Zone boundary
1,80	
2,80	Zone boundary
4,50	A/B boundary
7,10	0,71 to 4,5 boundary
9,30	B/C boundary
11,2	1,8 to 9,3 boundary
14,7	Zone boundary
18,0	C/D boundary
28,0	
45,0	4,5 to 14,7 boundary

GRUNDFOS
Date: _____
Signature: _____
Name: _____
Dept.: _____

be think innovate **GRUNDFOS**
Part no. 96507932/PMI/000/1249870

TM034167

Motor test report

be think innovate **GRUNDFOS**

Motor test report

Customer name	
Customer order no.	
Customer TAG no.	
GRUNDFOS order no.	
GRUNDFOS DUT id.	
Part number	
Motor no.	
Motor serie no.	

We the undersigned hereby guarantee and certify that the above motor has been tested. The performance of the motor can be seen in the motor test report on the next page.

GRUNDFOS
Date: _____
Signature: _____
Name: _____
Dept.: _____

be think innovate **GRUNDFOS**
Part no. 96507933P01/PMI/000/1135258

TM034146

Cleaned and dried pump

Report

Cleaned and dried pump

General info	
Customer name	
Customer order no.	
Customer TAG no.	
GRUNDFOS order no.	
Pump type	Part number
Serial number	Model

We the undersigned hereby confirm that the above-mentioned product is manufactured according to specifications mentioned in data booklet for the relevant product type. This means that prior to assembly, pump components are washed in pure, hot soapy water, rinsed in de-ionized water and dried.

The pump is wrapped in a plastic bag before being packed.

The pump has not been performance-tested.

GRUNDFOS
Date: _____
Signature: _____
Name: _____
Dept.: _____

be think innovate **GRUNDFOS**
Part no. 96507934/PMI/000/1252874

TM034145

Vacuum-dried pump

be think innovate **GRUNDFOS**

Vacuum Dried Pump

Customer name	
Customer order no.	
Customer TAG no.	
GRUNDFOS order no.	
GRUNDFOS DUT id.	
Part number	

GRUNDFOS hereby confirms that the pump mentioned above is manufactured according to the specifications mentioned in the "CR, CRI, CRN Custom-built pumps" data booklet. This means that after the performance test of the pump, a heat and vacuum drying process will ensure that no liquid water is present inside the pump.

The in-and outlet of the pump is sealed by means of a sticker after the drying process.

GRUNDFOS
Date: _____
Signature: _____
Name: _____
Dept.: _____

be think innovate **GRUNDFOS**
Part no. 98606312/PMI/000/1221711

TM060335

Electropolished pump

Report
Electro-polished pump

General Info			
Customer name			
Customer order no.			
Customer TAG no.			
GRUNDFOS order no.			
Pump type	Part number		
Serial number	Model		

Grundfos hereby confirms that the pump mentioned above is manufactured according to below specifications prior to assembly.

All components are treated according listed steps:

- 1) Degreased in a mechanical washing tunnel with soap.
- 2) Pickled in a mixture of nitric- or hydrofluoric acid (HF)
- 3) Electropolished in Sulfuric acid (H₂SO₄) and Phosphoric acid (H₃PO₄)
- 4) Passivated in 10-12% Nitric acid (HNO₃)
- 5) Washed in a mechanical washing tunnel without soap

The casted parts for a CRN 1s to a CRN 20, are all mechanically polished before being electropolished.

The pump will then obtain following surface roughness

Pump type	Stainless steel casted parts	Stainless steel plate and other non-casted parts	Surface roughness Ra [µm]
CRN1s, 1, 3, 5	X	X	Equal to or below 0,8
CRN10, 15, 20	X	X	Equal to or below 0,8

GRUNDFOS
Date: _____

Signature: _____
Name:
Dept.:

GRUNDFOS
Date: _____

Signature: _____
Name:
Dept.:

be think innovate **GRUNDFOS**
Part no. 96507935/PPM/000/1250017

TM034144

ATEX-approved pump

Report
ATEX approved pump

General Info			
Customer name			
Customer order no.			
Customer TAG no.			
GRUNDFOS order no.			
Pump type	Part number		
Serial number	Model	Serial No.	
Pump part No.	Model	Serial No.	
Motor part No.	Model	Serial No.	
ATEX Approval of pump	Technical File No.		

GRUNDFOS hereby confirms that the pump mentioned above is manufactured according to the ATEX directive. This means the pump is conformity with the ATEX 2014/34/EU ANNEX VIII directive as mentioned in the "ATEX Supplement to installation and operating instructions" supplied with the pump.

GRUNDFOS
Date: _____

Signature: _____
Name:
Dept.:

GRUNDFOS
Date: _____

Signature: _____
Name:
Dept.:

be think innovate **GRUNDFOS**
Part no. 96512240/PPM/000/1281066

TM034166

Motor routine test

Motor Routine Test
Model: MG, MGE
According to 60034-1:2010*

General Info			
Customer name			
Customer order			
Customer TAG no.			
GRUNDFOS order no.			
Pump type	Part number		
Serial number	Model	Serial No.	
Motor part No.	Model	Serial No.	

We the underdesigned hereby guarantee and certify that the materials and/or parts for the above mentioned product were manufactured by GRUNDFOS, tested, inspected, and conform to the full requirements of the appropriate catalogues, drawings and/or specifications relative thereto.
The attached test result is from the above mentioned motor.

*Exception to the standard EN60034-1 is that the no load losses are not measured, whereas the no load current is measured.

GRUNDFOS
Date: _____

Signature: _____
Name:
Dept.:

GRUNDFOS
Date: _____

Signature: _____
Name:
Dept.:

be think innovate **GRUNDFOS**
Part no. 9985062/PPM/000/1357944

TM08509

Pump performance testing

CR testers are all capable of performing hydraulic performance tests according to ISO 9906:2012 requirements.

The standard ISO 9906:2012 sets standards for rotodynamic pumps, Hydraulic performance acceptance tests, Grades 1, 2 and 3.

Performance acceptance grades

Six pump-performance-test acceptance grades, 3B, 2B, 2U, 1B, 1E and 1U are defined in ISO 9906:2012.

Acceptance grade	Mandatory measurements		Optional measurements	
	Q	H	P1	Eta-tot
3B	± 9 %	± 7 %	+ 9 %	- 7 %
2B	± 8 %	± 5 %	+ 8 %	- 5 %
1B	± 5 %	± 3 %	+ 4 %	- 3 %

Q: Flow rate

H: Head

P1: Total consumed power

Eta-tot: Total efficiency

These tolerance grades can be used in the contract between the pump manufacturer and the purchaser, or they can be used in a default tolerance factor that applies if no specific tolerance grade has been agreed between the manufacturer and the customer.

The guarantee point

According to ISO 9906:2012, the acceptance-grade tolerance applies to one guarantee point.

A guarantee point is defined by a guaranteed flow rate and a guaranteed head.

In addition, either minimum total efficiency or maximum total input power may be guaranteed at the specified conditions.

This means that the standard sets guidelines for a duty point guaranteed for one of the following:

- Q and H
- Q, H and total efficiency (Eta-total)
- Q, H and total consumed power (P1).

The guarantee point is defined by a minimum of five measured test points.

Example on a duty point test living up to ISO 9906:2012 requirements:

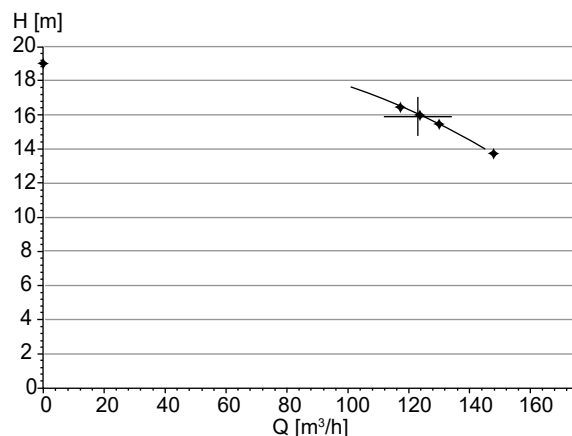

TM070448

Five measured test points are used to verify one guarantee point

Evaluation of performance

The test must show that the measured pump curve touches or passes through a tolerance surrounding the guarantee point as defined by the selected acceptance grade.

Guarantee-point evaluation must be made at the rated speed, that is, 50 Hz or 60 Hz for CR pumps.

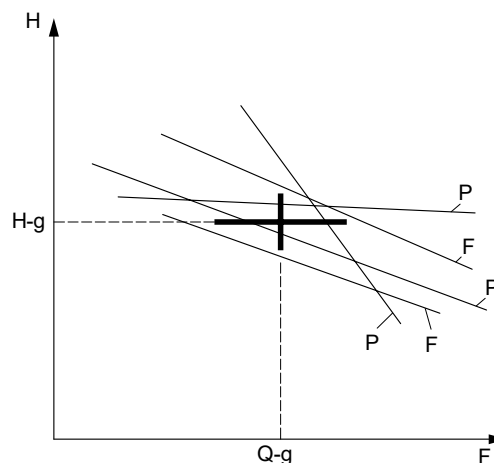

TM071544

Pump curves that either pass or fail to cross the tolerance cross of the guarantee point

Pos.	Description
1	Head
2	H-guaranteed
3	Q-guaranteed
4	Flow
5	Pass
6	Fail

Performance-test types for pumps

Two types of performance tests are available for CR pumps:

- duty-point-verification test
- curve test.

Tests carried out on pumps

Tests are saved for at least five years and can be traced using the unique serial number of the pump.

It is not possible to change the acceptance grade on an already tested and supplied pump. If this is required, a re-test of the pump is needed.

Witness testing can be arranged.

Duty-point-verification test, Grades 3B, 2B and 1B

This test method offers the possibility to perform a duty-point verification of one of the following:

- Q and H
- Q, H and total efficiency (Eta-tot)
- Q, H and total consumed power (P1).

Acceptance grade	Mandatory measurements		Optional measurements	
	Q	H	P1	Eta-tot
3B	Standard		On request	
2B	On request		On request	
1B	On request		On request	

What Grundfos is able to guarantee for the different acceptance grades is evaluated case by case. Contact your local sales company for further information.

Grundfos makes duty-point verification according to ISO 9906:2012 for one guarantee point at full speed, 50 or 60 Hz. The customer must tell Grundfos which duty point to verify.

The requested duty point is verified by five measured points.

Curve test, Grade 3B

This test method is developed by Grundfos and is based on ISO 9906:2012 performance acceptance grade 3B tolerances: $Q = \pm 9\%$, $H = \pm 7\%$.

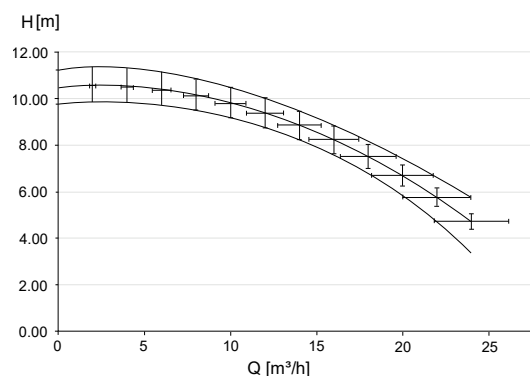

Q-H curve with tolerance crosses on the complete performance range

On the figure above, tolerance crosses according to Grade 3B have been distributed across the complete performance range of a pump. We generate the upper and lower limit of the performance curve by drawing two curves at the outlines of these crosses.

When the pump is tested and the measured point is located within the range between upper and lower limit, it is qualified to ISO 9906:2012 Grade 3B tolerances. This way of qualifying the pump performance is stricter than a duty-point-verification test for Grade 3B.

TM073766

How does Grundfos make curve testing for CR pumps

Grundfos makes the curve test in one of the following two ways:

- a reference-curve test
- a performance-curve test.

Reference-curve test, Grade 3B

A reference test is made when no curve-test report is specified with the order. Two test points are measured and no curve-test report is supplied with the pump. Measurements are made to maintain and observe continuous quality and to ensure that the supplied pump is within test-grade tolerances. Test-grade tolerances are set as for Grade 3B but without certification.

Example of a reference-curve test

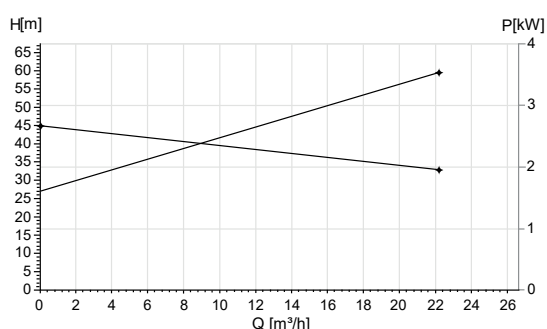

Measured values for a tested pump

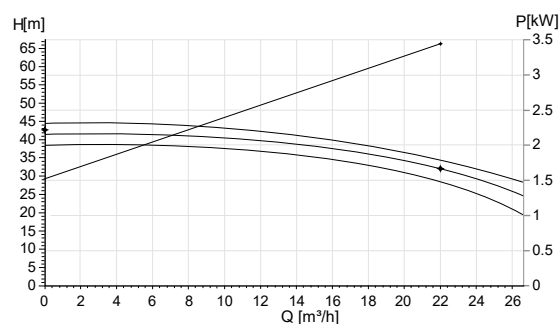

Measured values for a tested pump calculated to a reference speed for comparison to a reference performance curve

If a pump-performance report is requested at a later stage, only reference-test data are available.

Performance-curve test, Grade 3B

A performance-curve test is made when a curve-test report is specified with the order.

The pump is tested at minimum five pre-specified flow rates distributed over the full pump curve. Test grade tolerances are set as for Grade 3B but without certification.

Example of a performance-curve test

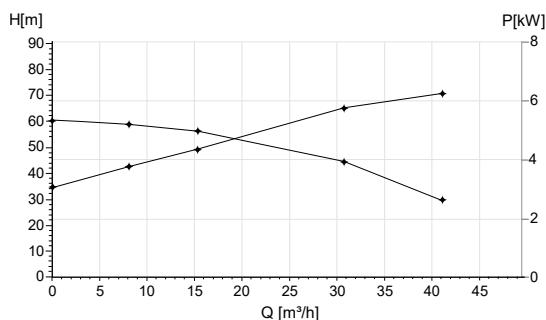

Measured values for a tested pump

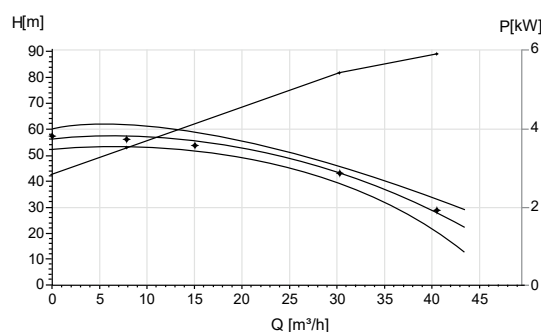

Measured values for a tested pump calculated to a reference speed for comparison to a reference performance curve

If the customer requires more points on the curve to be checked, individual measurements must be made that are not part of the performance-curve test.

Static high-pressure test

All pumps are static-pressure tested at 150 % of the maximum pressure stamped on the nameplate or at a maximum of 45 bar.

10. CRE pump solutions



TM056774

Motors for CRE, CRIE, CRNE pumps

Besides continuous variable performance, CRE, CRIE and CRNE pumps offer a number of advantages, depending on the hardware and software combinations of the motor.

CRE pumps are not dependent on the frequency of the supply voltage and are designed for operation at frequencies between 750 rpm and 6000 rpm. This offers a number of advantages:

- compact pump
- higher performance in relation to physical size
- larger dynamic range
- less noise at reduced speed
- more gentle handling of the pumped liquid at reduced speed.

The speed may be chosen freely, taking into consideration the maximum motor load and the hydraulic properties of the pump. Pumps can be delivered with oversize or undersize motors, depending on load profile. The configuration of the ball bearing can also be altered to fit load and demands.

Customized CRE pump solutions

As an alternative to the standard CRE pump solutions, we offer CRE pumps customized for your requirements.

You can configure CRE pumps as follows:

- Select an operating panel on the front of the terminal box of the motor.
- Select a communication module for bus standards such as GENIbus, LONWorks, PROFIBUS.
- Select a customized functionality by special configuration files (gsc-files).

Related information

[Communication with CRE pumps](#)

Control options

It is possible to communicate with E-pumps via the following platforms:

- operating panel on the pump
- Grundfos GO
- Grundfos GO Link
- central management system.

The purpose of controlling an E-pump is to monitor and control the pressure, temperature, flow rate and liquid level of the system.

Related information

[Grundfos GO](#)

[Operating panels](#)

[Grundfos GO Link](#)

[Central management system](#)

Operating panels

The operating panel on the E-pump terminal box makes it possible to change the setpoint settings manually.

All settings are saved if the power supply is switched off. The operating panel can be delivered with or without a radio module for communication between the pump and Grundfos GO, or communication to other pumps in a multipump system. All operating panels enable communication via infrared (IR) connection that can be used in connection with Grundfos GO. Communication via Bluetooth (BLE) connection is available for MGE 3 to 26 kW motors.

CRE pumps can be delivered with different operating panels. See the table below:

	Operating panel type					
	Basic		Standard		Advanced	
MGE motor	HMI 100	HMI 101	HMI 200	HMI 201	HMI 300	HMI 301
0,37 - 26 kW	○	○	●	○	●	○

- Mounted as standard
- Optional

The following operating panels include an integrated radio module:

- HMI 100
- HMI 200
- HMI 300.

The following operating panels do not include an integrated radio module:

- HMI 101
- HMI 201
- HMI 301.

Note that all panels include an advanced functional module.

Basic operating panel, HMI 100 and HMI 101

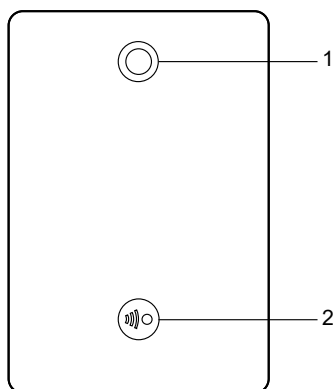

TM054847

Pos.	Symbol	Description
1		Grundfos Eye: Indicator light showing the operating status of the product
2		Radio communication: Button enabling radio communication with Grundfos GO

Standard operating panel, HMI 200 and HMI 201

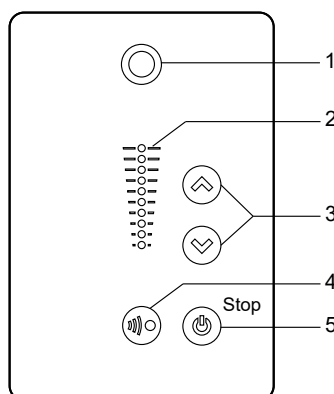

TM054848

Pos.	Symbol	Description
1		Grundfos Eye: Indicator light showing the operating status of the product
2	-	Light fields for indication of the setpoint
3		Up/Down: Buttons to change the setpoint
4		Radio communication: Button enabling radio communication with Grundfos GO
5		Start/Stop: Button for starting and stopping the product

Advanced operating panel, HMI 300 and HMI 301

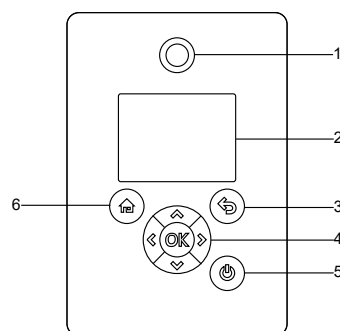

TM054849

Pos.	Symbol	Description
1		Grundfos Eye: Indicator light showing the operating status of the product
2	-	Graphical colour display.
3		Back: Button for going one step back
		Left/Right: Button navigating between main menus, displays and digits
4		Up/Down: Buttons navigating between submenus or change the value settings
		OK: Button for saving changed values, resetting alarms, expanding the value field and enabling radio connection with Grundfos GO
5		Start/Stop: Button for starting and stopping the product
6		Home: Button for going to the Home menu

Remote control

Grundfos GO

Use Grundfos GO for the following types of wireless communication with the pump:

- infrared
- radio
- Bluetooth.

MGE 0.37 to 2.2 kW

These motors connect to the pump through wireless infrared or radio communication.

MI 301

MI 301 is a module with built-in infrared and radio communication. It is required for Grundfos GO communication. MI 301 can be used together with Android or iOS-based smart devices with a Bluetooth connection. MI 301 has a rechargeable Li-ion battery that must be charged separately.



MI 301

The following are supplied with the product:

- Grundfos MI 301
- sleeve
- battery charger
- quick guide.

Product numbers

Grundfos GO variant	Product number
Grundfos MI 301	98046408

MGE 3 to 26 kW

These motors connect to the pump via Bluetooth (BLE).

Bluetooth

For MGE motors from 3 to 26 kW, the product incorporates a Bluetooth (BLE) module for remote control. For MGE motors from 0.37 to 2.2 kW, see the detailed description about Grundfos GO.

Via the built-in Bluetooth module, the product can communicate with the Grundfos GO. Bluetooth communication can take place at distances up to 10 metres.

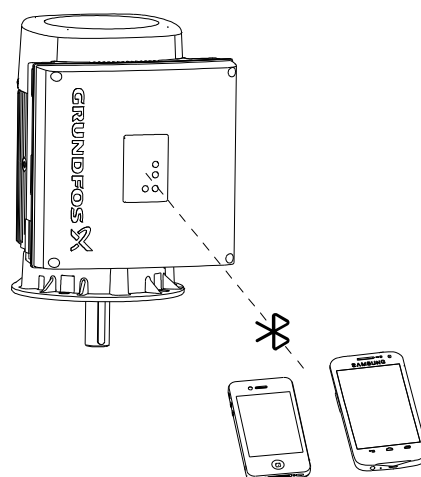

TM062930

Bluetooth information

Frequency of operation	2400 - 2483.5 MHz
Modulation type	GFSK
Data rate	2 Mbps
Transmit power	5 dBm EIRP with internal antenna

GLoWpan information

Frequency of operation	2405-2480 MHz
Modulation type	GP O-QPSK
Data rate	1 Mbps
Transmit power	5 dBm EIRP with internal antenna

TM053890

Communication with CRE pumps

Communication with CRE pumps is possible via a central building management system, remote control or operating panel.

Central management system

Communication with the E-pump is possible even if the operator is not present near the E-pump. Communication is enabled by connecting the E-pump to a central building management system. This allows the operator to monitor the pump and change control modes and setpoint settings.

Communication between E-pumps and a central building management system is enabled via a Grundfos Communication Interface Module (CIM).

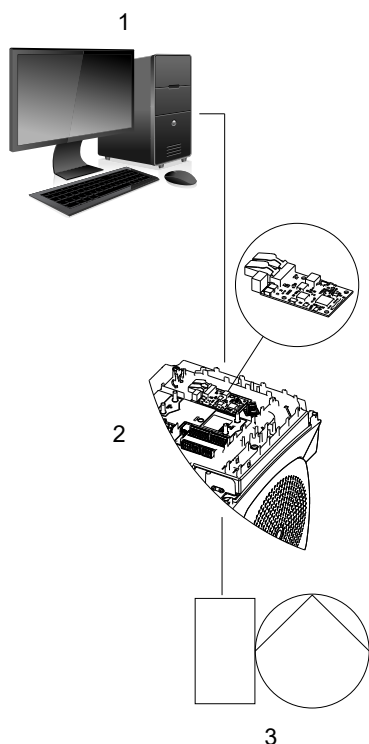

TM084691

Structure of a central management system

Pos.	Description
1	Central management system
2	CIM ²⁵⁾
3	E-pump

²⁵⁾ See the section on Communication Interface Modules.

Grundfos GO Link

The product is designed for wired or wireless communication with the Grundfos GO Link.

The Grundfos GO Link enables you to set functions and gives you access to status overviews, configuration and current operating parameters.

Use the Grundfos GO Link together with the following interfaces:

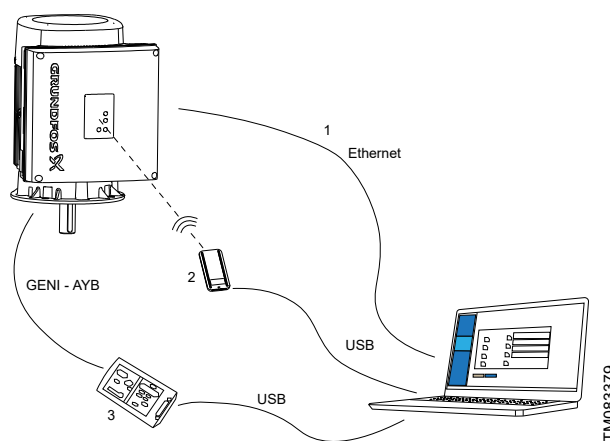

TM083379

Grundfos GO Link setup

Pos.	Description
1	Ethernet cable: Standard Ethernet cable CAT5/CAT6
2	Grundfos MI 301: Separate module enabling radio communication. Use the module together with a USB cable to connect to a laptop
3	Grundfos PC Tool Link: Separate module enabling wired connection to the pump. Use the module together with a USB cable to connect to a laptop

Grundfos PC Tool E-products

Connection of Grundfos PC Tool E-products²⁶⁾ offers a number of advantages during commissioning, operation and service of E-pumps.

PC tool E-products enables the following functions:

- monitoring of operational status of your E-product
- standard configuration of E-products
- custom configuration of E-products
- saving of logged data from E-products.

Via the PC Tool, it is possible to download special predefined configuration files (gsc files) to the pump. The configuration files may contain application-optimised operating parameters based on your specifications.

When configuration files are read, it is still possible to adjust parameters.

Description

Grundfos PC Tool E-products is a common user platform or user interface used throughout the entire production process of an E-pump. Furthermore, PC Tool E-products can be used by the customer to set, commission and service the E-pump.

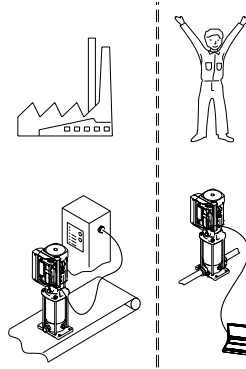

PC Tool E-products used by the customer in production and on site

Grundfos PC Tool E-products enable configuration or reconfiguration of your product to optimise it to your application. Furthermore, it is indispensable for fault finding and service.

The software for Grundfos PC Tool E-products must be ordered with the PC Tool Link package that contains hardware and cables. Contact Grundfos for further information.

TM039290

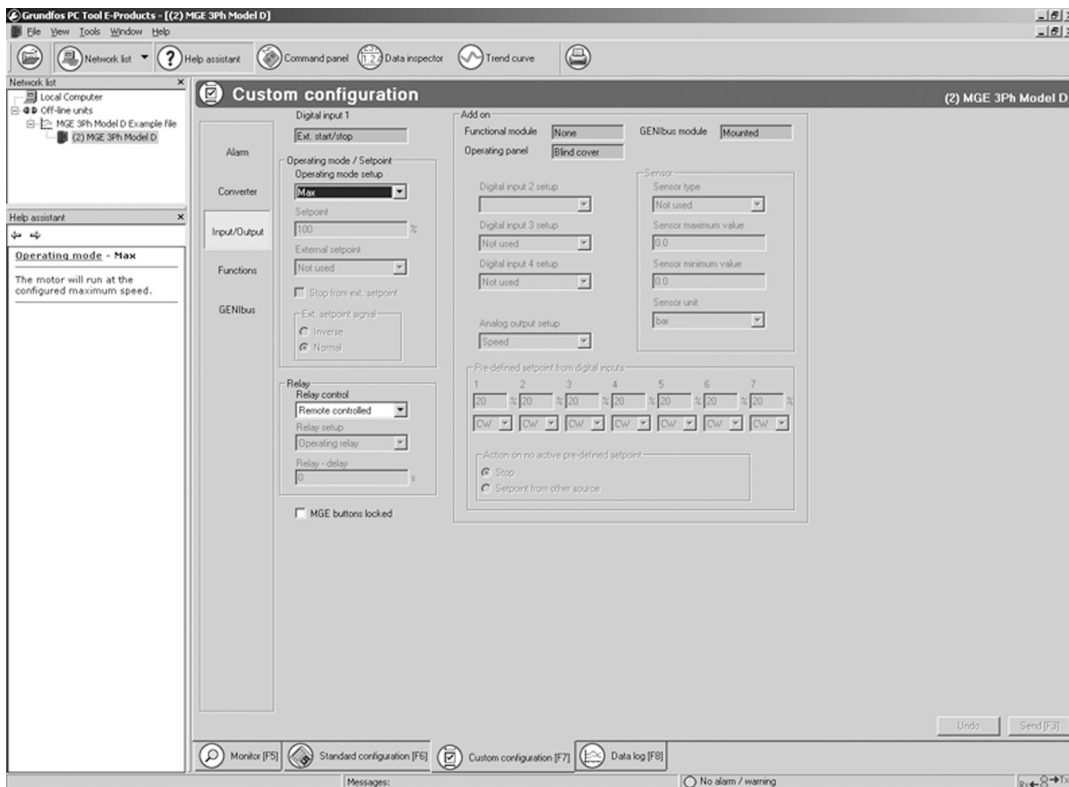

TM033712

PC Tool interface

²⁶⁾ Note that the PC Tool is available for MGE 0.37 - 2.2 kW motors.

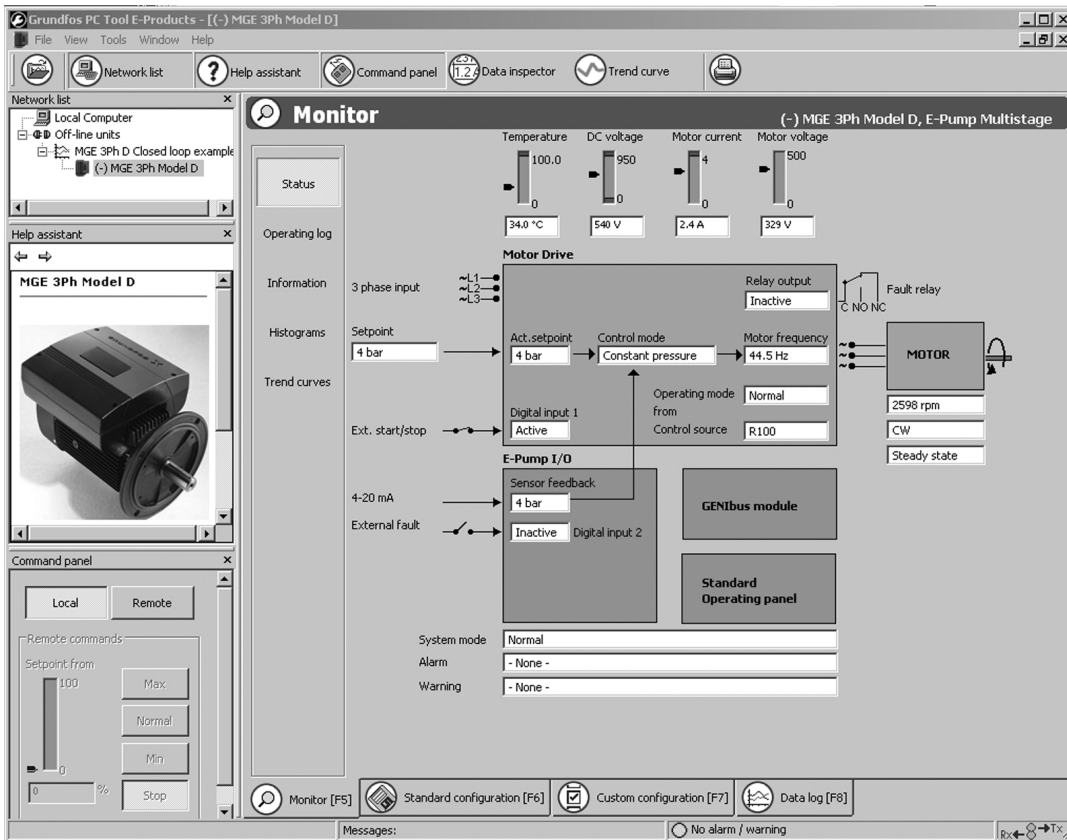

TM044607

Monitoring function

Industrial custom-built E-solutions

Pump running at over-synchronous speed

Pumps running at over-synchronous speed run at speeds exceeding the standard, maximum speed, for example, 50/60 Hz.

By increasing the pump speed, the pump performance increases even more due to the laws of affinity. If you increase the speed of the pump with 20 % from 2,900 rpm to 3,470 rpm, the pump performance increases by more than 70 %.

Affinity equations

Normally, speed-regulated pumps are used in applications characterized by a variable flow rate. Consequently, you cannot select a pump that is constantly operating at its optimum efficiency.

To achieve optimum operating economy, select the pump based on the following criteria:

- The maximum duty point must be as close to the QH curve of the pump as possible.
- The required duty point must be positioned so that P2 is close to the maximum point of the QH curve.

The flow rate of the required duty point must be close to the optimum efficiency (eta) for most operating hours.

Between the minimum and maximum performance curves, speed-regulated pumps have an infinite number of performance curves, each representing a specific speed. You may therefore not be able to select a duty point close to the maximum curve.

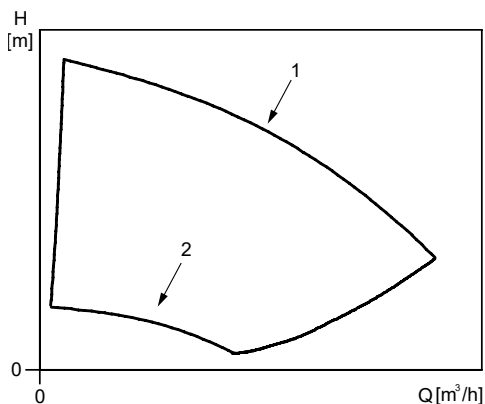
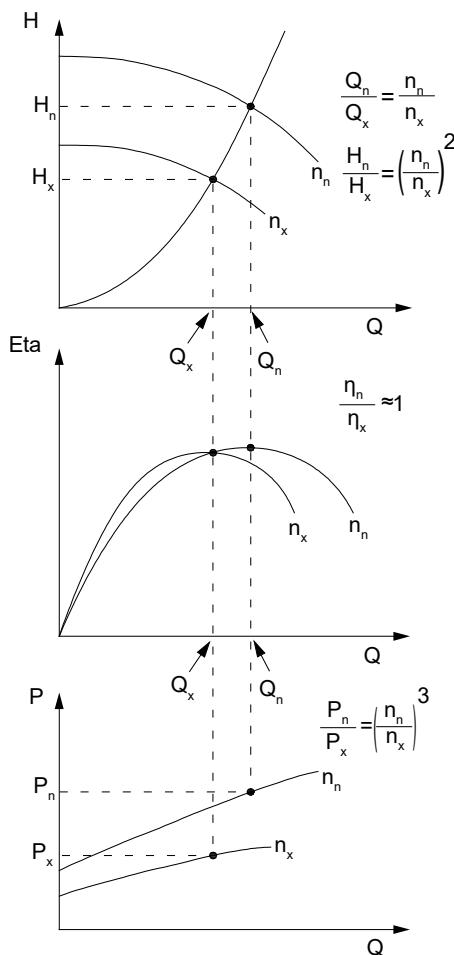

Maximum (1) and minimum (2) performance curves

In situations where you cannot select a duty point close to the maximum curve, use the affinity equations below. The head (H), the flow rate (Q) and the input power (P) are the appropriate variables for calculating the motor speed (n). Note that the approximated formulas apply on condition that the system characteristic remains unchanged for n_n and n_x , and that it is based on the formula $H = k \times Q^2$ where k is a constant.

The power equation implies that the pump efficiency is unchanged at the two speeds. In practice, this is not quite correct.

To obtain a precise calculation of the power savings resulting from a reduction of pump speed, take into account the efficiencies of the frequency converter and the motor.

Affinity equations

Legend

H_n	Rated head [m]
H_x	Current head [m]
Q_n	Rated flow rate [m ³ /h]
Q_x	Current flow rate [m ³ /h]
n_n	Rated motor speed [rpm]
n_x	Current motor speed [rpm]
η_n	Rated efficiency [%]
η_x	Current efficiency [%]
P_n	Rated power [kW]
P_x	Current power [kW]

TM014916

TM008720

Pump hydraulic limitations

Running over synchronous speed or pumping liquids with higher density than water increases the differential pressure over the chambers and the entire chamber stack. This might affect the lifetime of the pump depending on the application. Therefore, do not exceed the pressure limits stated in the table below. Special chambers and software setup might be required.

Chamber type	Max. differential pressure over the chamber [bar]				
	Pump size				
	1s	1-3	5	10-20	32-64
Standard - CR, CRI, CRN	0.9	0.9	0.9	2.2	5.0
Standard - CRE, CRIE, CRNE	1.25	1.25	1.25	2.5	5.0 ²⁷⁾
Reinforced	-	2.2	2.2	-	-
Laser-welded	-	2.2	-	-	-

²⁷⁾ The maximum speed for size 32-64 CRE and CRNE pumps is 3600 rpm.

The durability of the different chamber types depends on the number of starts and stops of the pump. The estimated maximum number of pump starts and stops is stated below:

Chamber type	Maximum number of starts and stops
Standard chamber	1,000,000
Reinforced chamber	300,000
Laser-welded chamber	800,000

Purpose and benefits

The table below states the maximum differential pressure over the entire chamber stack.

Pump type	Maximum differential pressure over the entire chamber stack [bar]
CR, CRI, CRN 1-3	50
CR, CRI, CRN 5	25
CR, CRI, CRN 10-20 ²⁸⁾	30
CR, CRI, CRN 32-64	33

²⁸⁾ Max. 25 bar for CRN S-version (SF pump).

Increasing RPM enables high pressure with few stages, requiring less space.

Traditionally, pumps are sized so that the maximum pressure and flow rate required in the application can be handled with a standard pump. For pumps working in conditions with various pressure and flow requirements, this may result in the most common duty point being where the pumping efficiency is not optimal. By choosing a pumping solution that can reach over-synchronous speeds, the pump can be sized from most common duty point and speed up when a higher flow rate or pressure is required.

In applications where a high flow rate or pressure is needed momentarily, sizing can be done from the most used duty point with the ability to run over-synchronous speed for momentary high flow rate or pressure.

Applications

This solution is ideal in cases where the pump weight and dimensions are to be kept at a minimum, and the pump performance is to be maintained.

The figure below illustrates how a pump can be down-sized and still deliver the same performance.

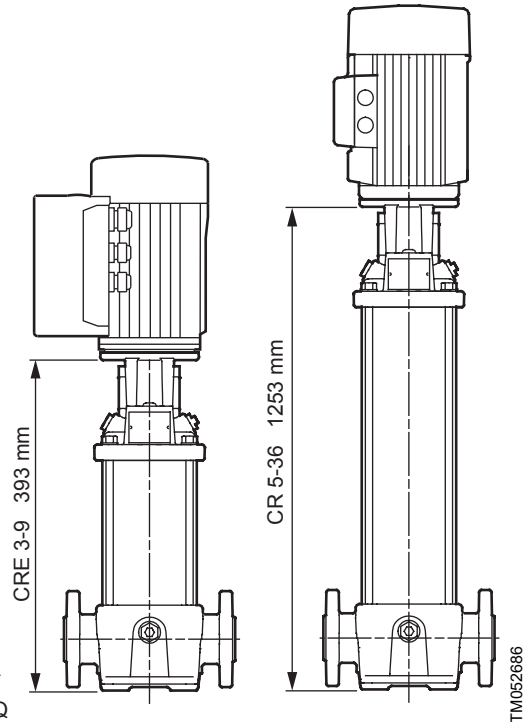
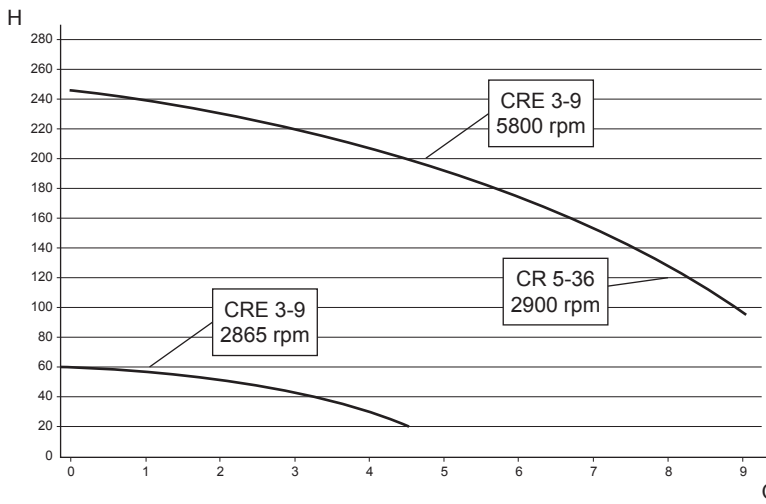

TM052686

Comparison of performance: CRE 3-9 running at over-synchronous speed matching the performance of a CR 5-36 running at rated maximum speed

Availability

This function is available in the following pump sizes:

Single-phase pumps	
2-pole	4-pole
0.37 - 1.5 kW	0.25 - 1.1 kW
Three-phase pumps	
2-pole	4-pole
0.37 - 26 kW	0.55 - 18.5 kW

Setup

This function is available in factory-configured products. Running at over-synchronous speed affects the NPSH value. Sufficient inlet pressure is therefore required. Sound pressure level emitted from the pump and motor increases when increasing the speed.

Pump operating at power limit

When a pump operates at the power limit, the MGE motor delivers an output corresponding to the maximum load stated on the nameplate. The maximum load is never exceeded.

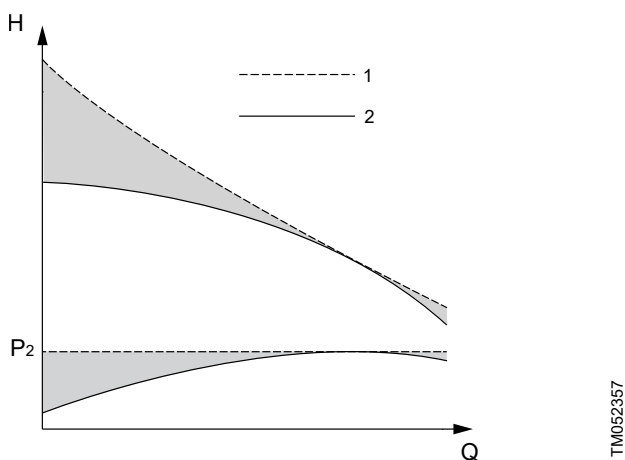

Curves of a standard E-pump and a pump operating at power limit

Pos.	Description
1	Power limit
2	Standard

Purpose and benefits

When using a standard pump at a low flow rate, the power consumption drops, and the motor has excess power available.

By setting the CRE pump to operate at a higher speed, the excess power can be used to provide a higher pressure. The power limit function ensures that the motor load never exceeds its maximum by decreasing the speed until the motor is at its power limit.

In cases where an undersize motor is used with standard speed, the power limit function still reduces the speed and protect the motor against overload at a high flow rate. The solution offers the following benefits:

- reduced motor size
- reduced pump size.

The figure below shows that a pump operating at low flow rates and relatively high pressures (1) can be fitted with an undersize motor with a rated power that matches this operating range. At higher flow rates and relatively lower pressures (2), the motor reduces its speed when the power limit is exceeded and follow a steeper curve corresponding to the power available.

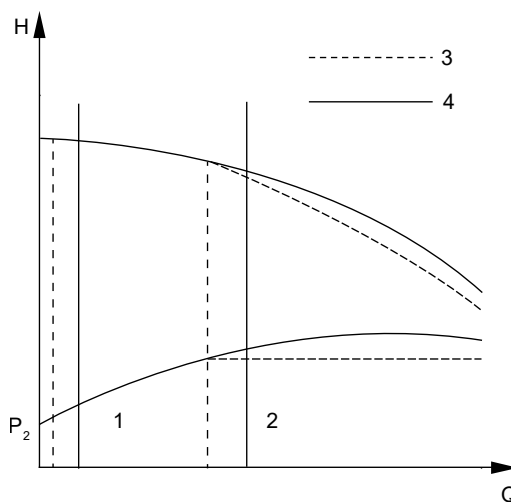

Standard performance curve compared to a curve for a pump fitted with an undersize MGE motor

Pos.	Description
3	Reduced motor
4	Standard motor

The MGE motor can be set to a higher speed than standard, enabling the pump to deliver more pressure. The pump operates at this higher speed until the pump reaches the flow rate where the motor is loaded to its full rated power. If the flow rate is increased further, the motor reduces its speed so as not to exceed its rated power. In some cases, using this function can enable a smaller pump to reach the desired duty point compared to a pump running with standard maximum speed. See the figure below.

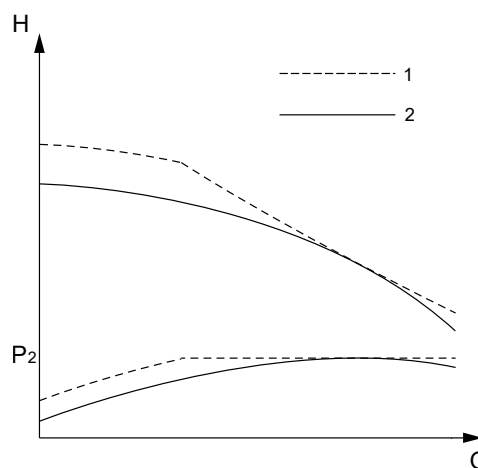

Standard performance curve (60 Hz) compared to a performance curve for a pump running at maximum speed

Pos.	Description
1	Maximum speed
2	Standard

Applications

The power limit function is primarily used in applications where the motor size is to be as small as possible to reduce size or cost. It is also used in applications demanding a high maximum speed to achieve a high pressure at a low flow rate. In both cases, the motor is protected by the power limit function at a higher flow rate where a lower speed is needed to prevent the motor from overloading.

Examples of application:

- Washing and cleaning
- boiler feed.

Availability

This function is available in the following pump sizes:

Single-phase pumps	
2-pole	4-pole
0.37 - 1.5 kW	0.25 - 1.1 kW

Three-phase pumps	
2-pole	4-pole
0.37 - 26 kW	0.55 - 18.5 kW

Setup

The power limit is always active in CRE pumps to protect the motor against overload. Pumps with undersize motor and pumps with higher maximum speed are available as factory-configured products.

Note that running at over-synchronous speed affects the NPSH value. Sufficient inlet pressure is therefore required.

Sound pressure level emitted from the pump and motor may increase at higher speeds.

Furthermore, the differential pressure over the chambers must be taken into consideration.

Related information

[Pump hydraulic limitations](#)

Low-flow stop function

The stop function ensures that the pump stops when low or no flow is detected, for example, if the pump is pumping against a closed valve.

Purpose and benefits

The stop function provides the following benefits:

- It limits energy consumption and increases system efficiency.
- It helps avoid unnecessary heating of pumped liquid.
- It reduces wear of shaft seals.
- It reduces noise from operation.

Applications

The stop function is used in systems with a diaphragm tank and where periodically low or no consumption can occur thus preventing the pump from running against a closed valve.

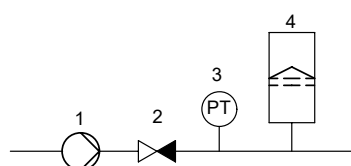

TM038563

Pos.	Description
1	Pump
2	Non-return valve
3	Pressure sensor
4	Diaphragm tank

Availability

This function is available in the following pump sizes:

Single-phase pumps	
2-pole	4-pole
0.37 - 1.5 kW	0.25 - 1.1 kW

Three-phase pumps	
2-pole	4-pole
0.37 - 26 kW	0.55 - 18.5 kW

Setup

This function is available in factory-configured products.

Stabilising unstable pump curves

When the pump curve has a shape where it intersects the system curve at two points (A and B) with identical pressure but at different flow rates, the pump curve is defined as unstable. This is especially problematic in systems with a flat system characteristic as it prevents the pump from being controlled to a flow rate lower than the flow rate at point B.

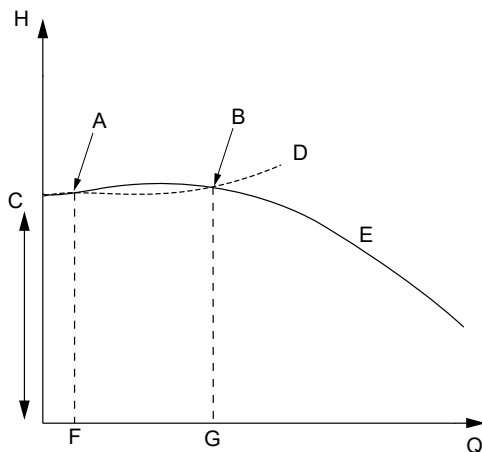

TM052491

Unstable pump curve

Pos.	Description
A	Intersection between pump curve and system curve
B	Intersection between pump curve and system curve
C	Counterpressure
D	Flat system characteristic
E	Unstable curve
F	2 m ³ /h
G	7 m ³ /h

The E-motor can stabilise an unstable pump curve in the low flow area by changing to a higher speed. The figure below illustrates how the pump curve is straightened out in this area. As the flow rate increases, the E-motor gradually reduces the speed to normal speed and the pump performance follows the standard pump curve.

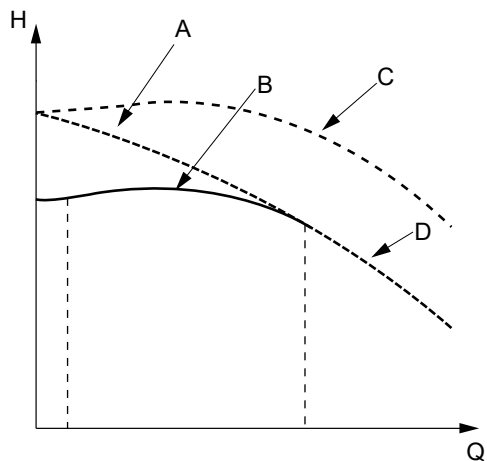

TM052434

Pump curve with a stabilised operating range

Pos.	Description
A	Stabilised pump curve
B	Unstable standard pump curve
C	58 Hz curve
D	50 Hz curve

Purpose and benefits

The purpose of stabilising an unstable pump is to enable normal control throughout the entire operating range, thereby achieving fully stable operation even in the low flow range. This enables the use of modern high-efficiency pumps in applications where this would otherwise not be possible.

Applications

Unstable operation may occur in applications with a high counterpressure and a flat system characteristic.

Examples of application:

- Pumping of water to a water tower
- boiler feed.

Note that the sound pressure level emitted from the pump and motor may increase at higher speeds.

Availability

This function is available in the following pump sizes:

Single-phase pumps	
2-pole	4-pole
0.37 - 1.5 kW	0.25 - 1.1 kW
Three-phase pumps	
2-pole	4-pole
0.37 - 26 kW	0.55 - 18.5 kW

Setup

This function is available in factory-configured products.

11. How to read the curve charts

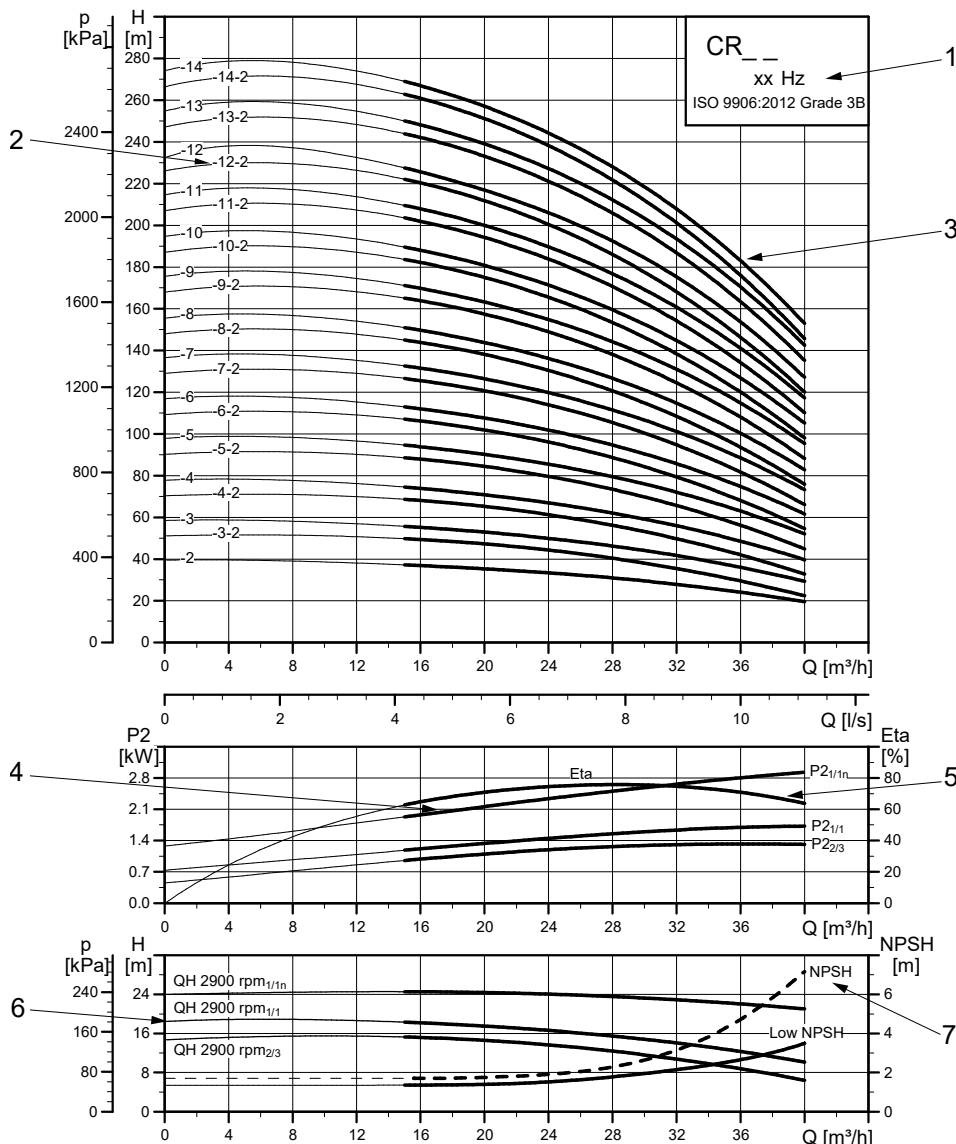

TM078875

Pos.	Description
1	It shows the pump type, frequency, poles or speed as well as the ISO or ANSI standard.
2	Number of stages. First figure: number of stages. Second figure: number of reduced-diameter impellers.
3	It is the QH curve of the individual pump with the bold curves indicating the recommended duty range for best efficiency.
4	The power curves indicate pump input power per stage . Curves are shown for a pump with one stage (1/1), low-NPSH stage (1/1n) and reduced-diameter impellers (2/3).
5	The eta curve shows the efficiency of a pump with an average number of stages. The efficiency of pumps with reduced-diameter impellers is approximately 2 % lower than the eta curve shown in the chart.
6	It is the QH for each individual impeller. Curves are shown for a pump with one stage (1/1), low-NPSH stage (1/1n) and reduced-diameter impellers (2/3).
7	The NPSH curve is a maximum curve for all the variants shown.

Guidelines to curve charts

The guidelines below apply to the performance curves:

- Tolerances apply to ISO 9906:1999, Annex A, if indicated.
- The motors used for the measurements are standard Grundfos motors (MG or MGE).
- Measurements are made with airless water at a temperature of 20 °C.
- Kinematic viscosity of ν equals 1 mm²/s (1 cSt).
- Due to the risk of overheating, do not use the pumps at a flow rate below the minimum flow rate. The QH curves apply to a rated motor speed of 2900 rpm.

The curve below shows the minimum flow rate as a percentage of the nominal flow rate in relation to the liquid temperature. The dotted line shows a CR pump fitted with an air-cooled top assembly.

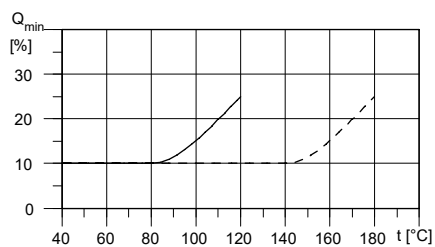

TM012816

Minimum flow rate

Guidelines to CR deep-well curve charts

CR deep-well

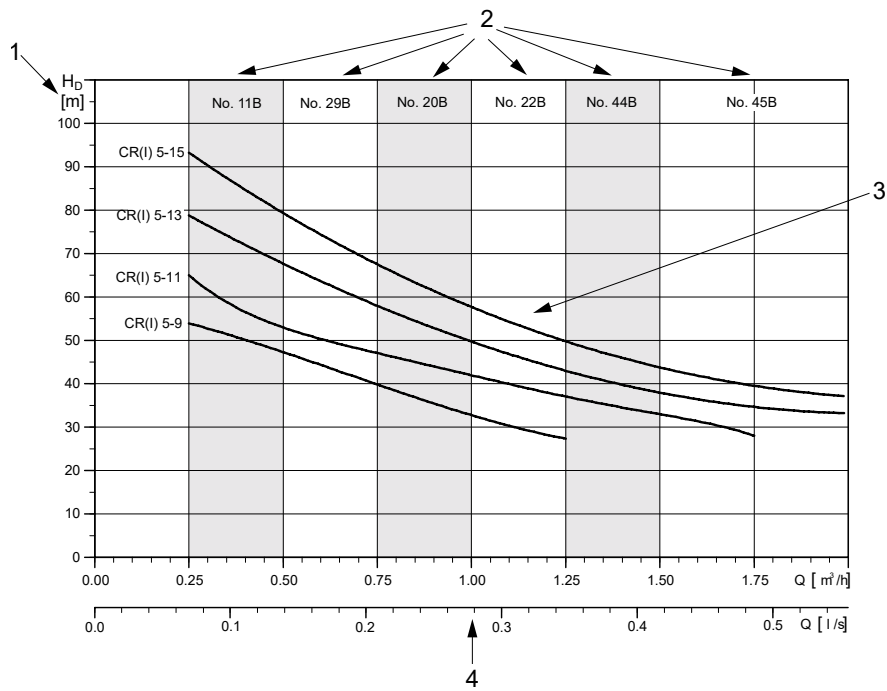

TM076876

Example of a curve chart of CR deep-well

Pos.	Description
1	The y-axis indicates the suction depth, H_D , in metres.
2	These are the ejector numbers.
3	It is the QH curve of the individual pump. The bold curves indicate the recommended performance range for best efficiency.
4	The x-axis indicates the flow rate in m^3/h and l/s .

12. Performance curves

CR deep-well

50 Hz

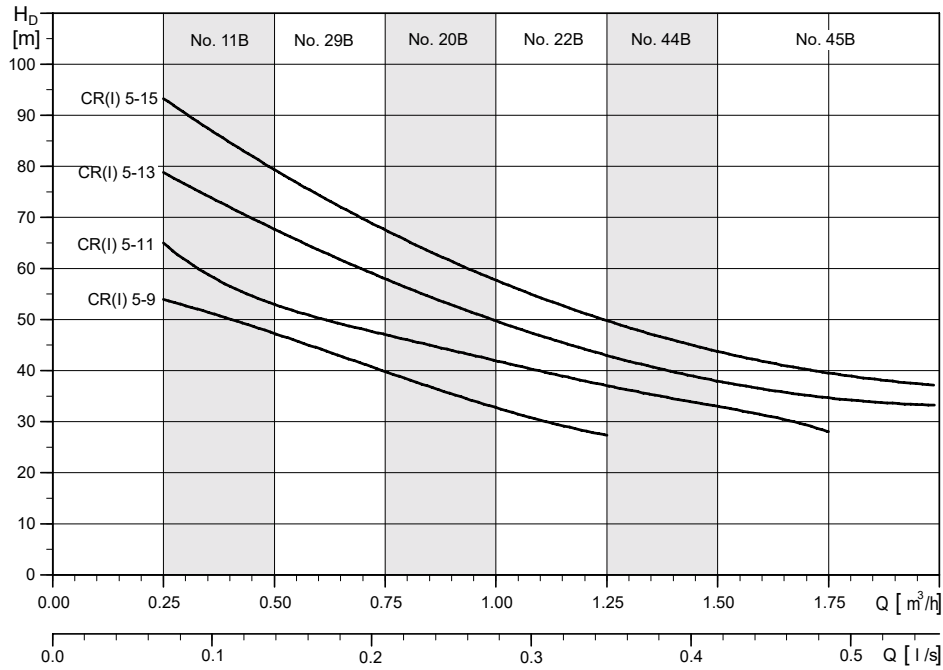

TM033096

60 Hz

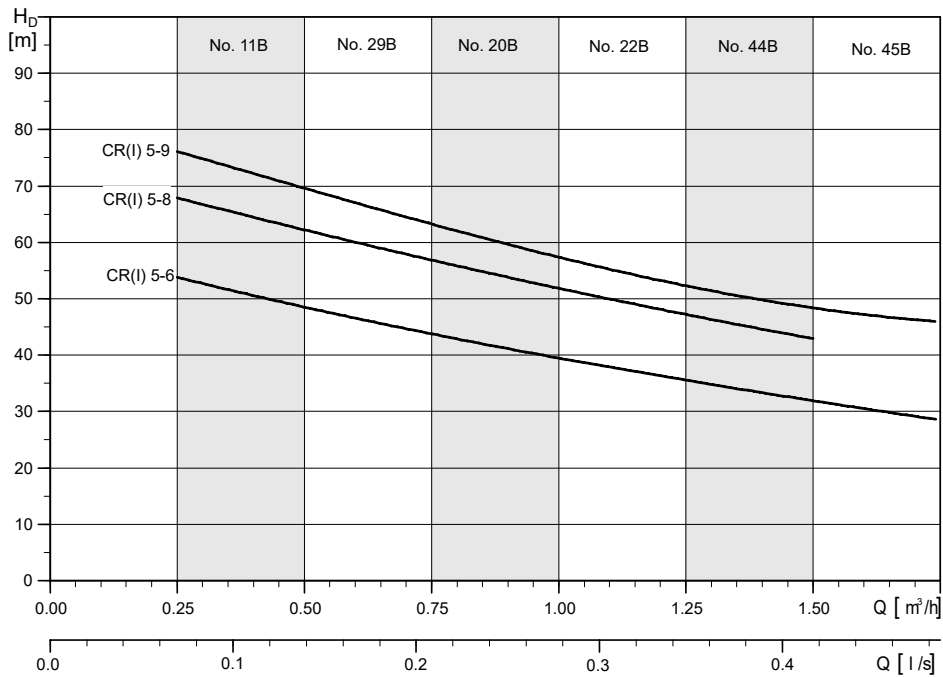

TM033971

Low-NPSH pumps, 50 Hz

Low-NPSH pumps with 2-pole motor, 50 Hz: CR, CRI, CRN 3

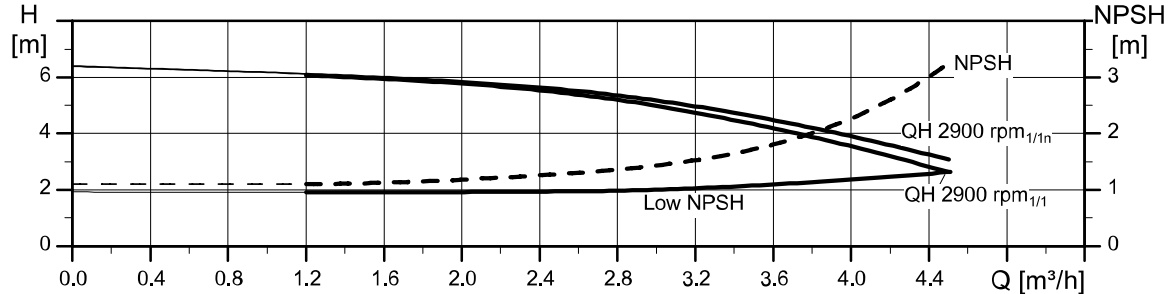
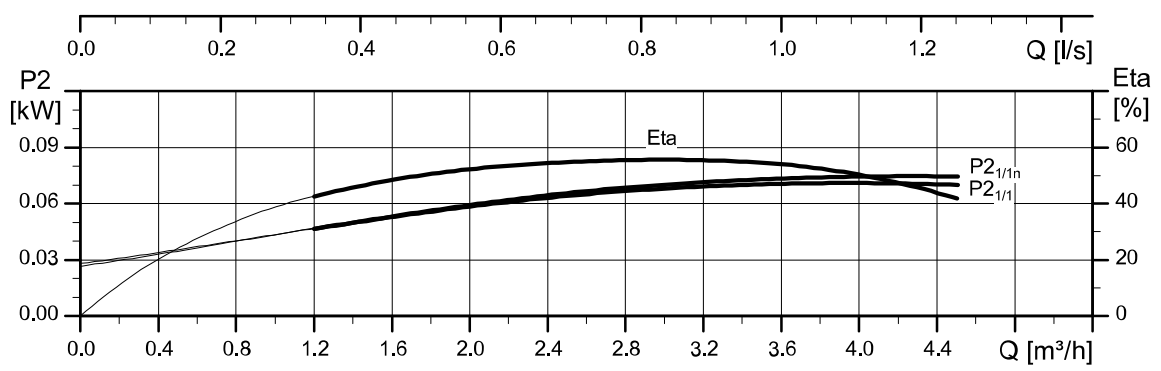
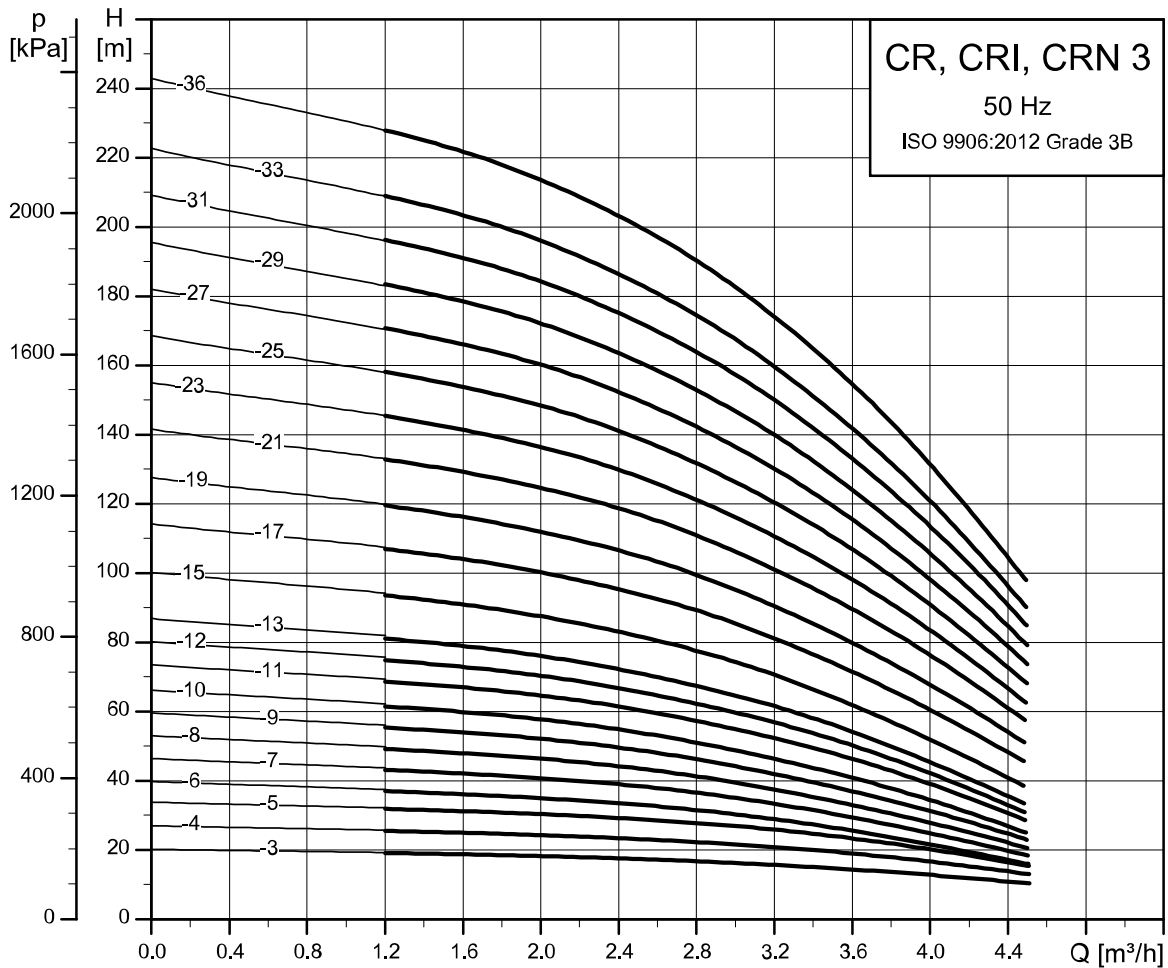

TMX21186

Low-NPSH pumps with 2-pole motor, 50 Hz: CR, CRI, CRN 5

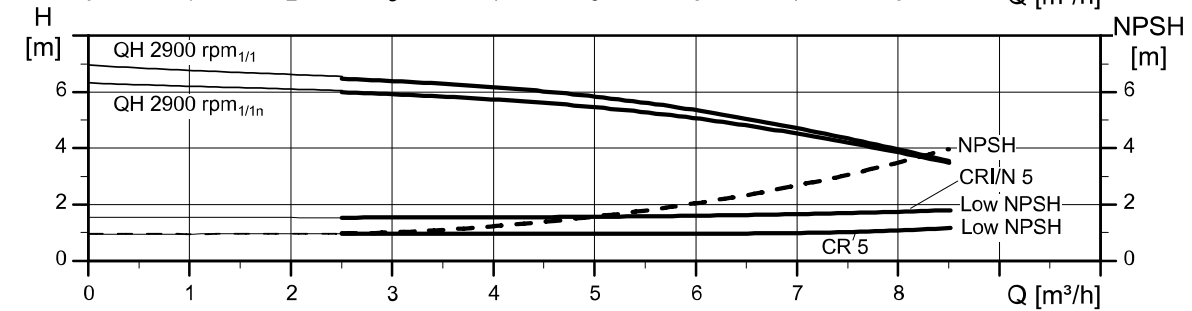
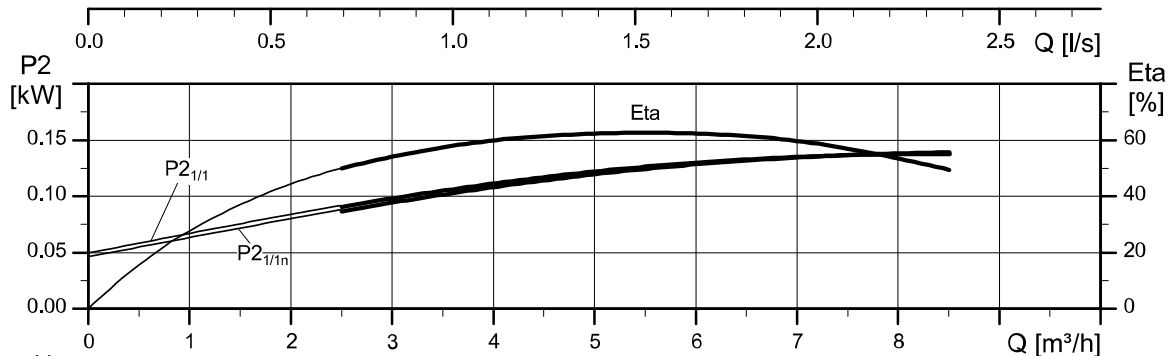
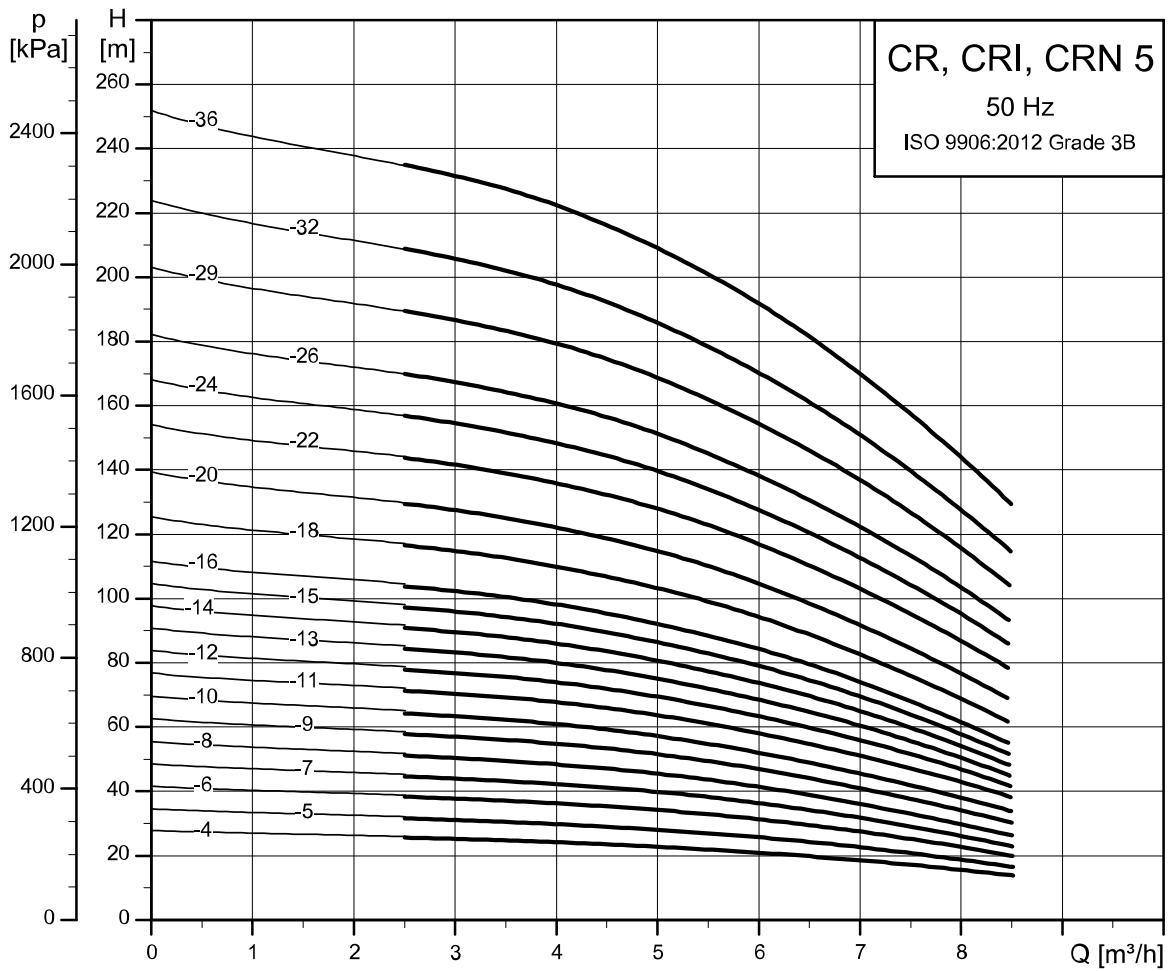

TMX21189

Low-NPSH pumps with 2-pole motor, 50 Hz: CR, CRI, CRN 10

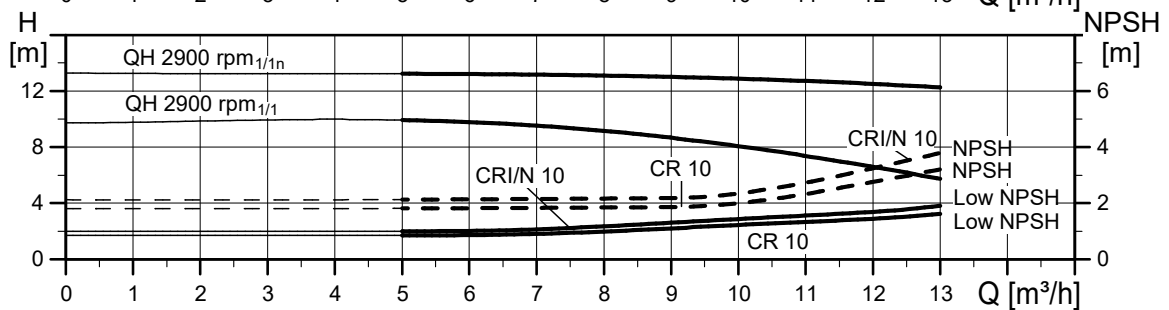
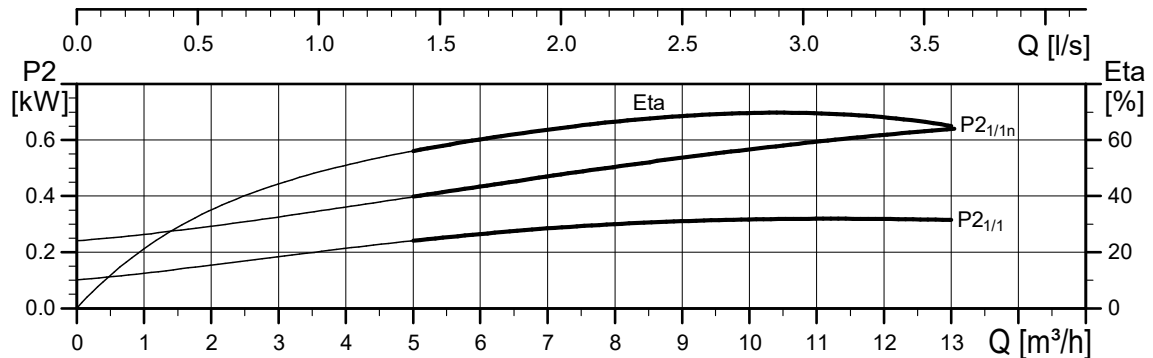
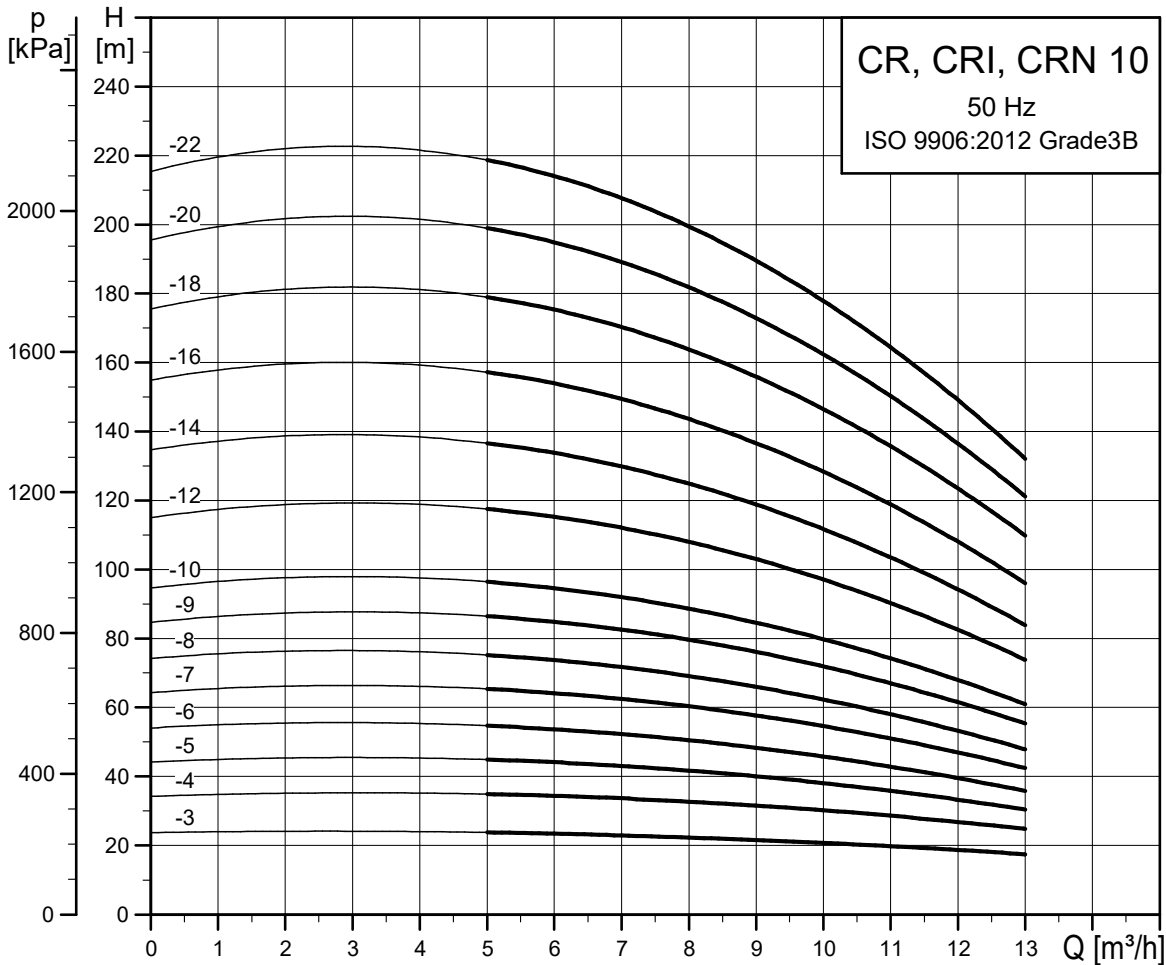

TM027391

Low-NPSH pumps with 2-pole motor, 50 Hz: CR, CRI, CRN 15

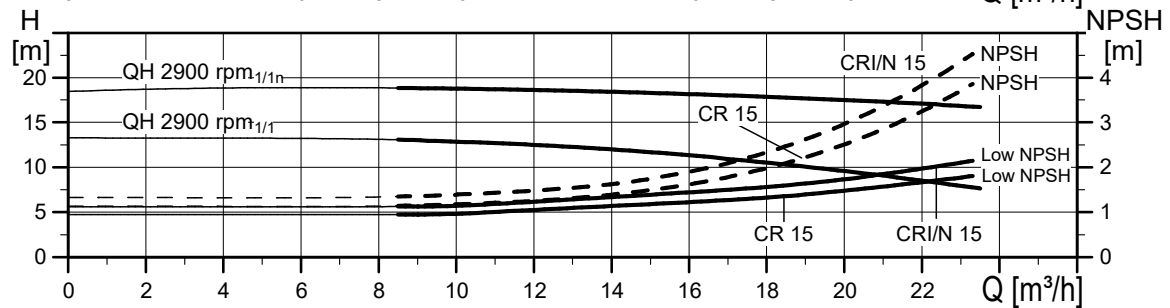
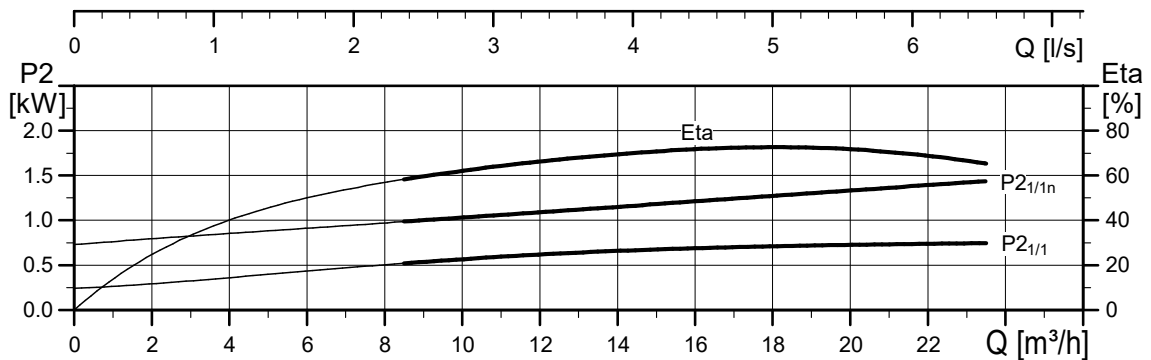
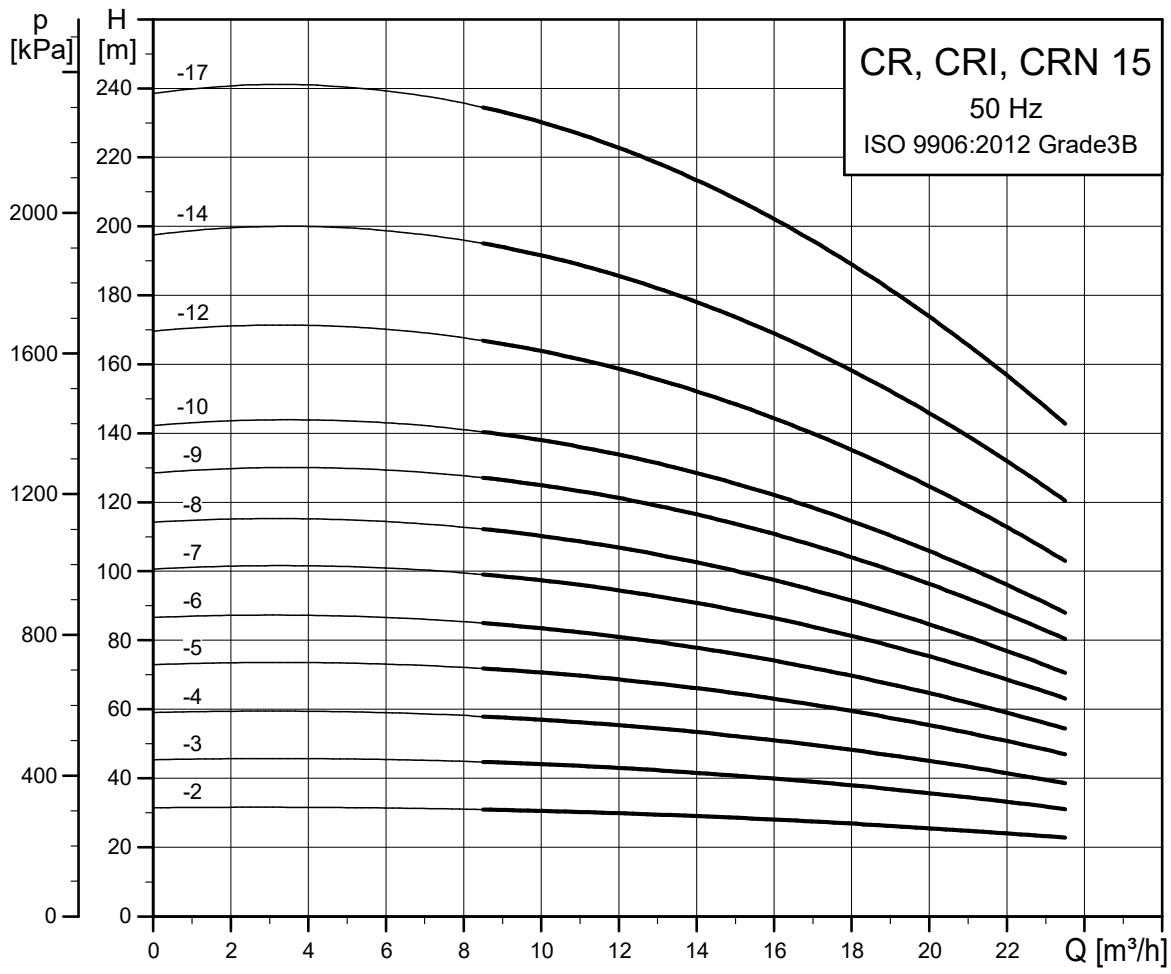

TM027392

Low-NPSH pumps with 2-pole motor, 50 Hz: CR, CRI, CRN 20

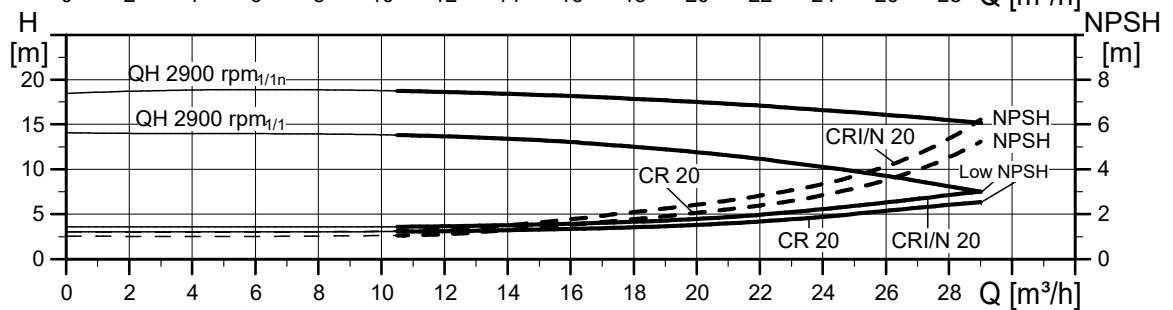
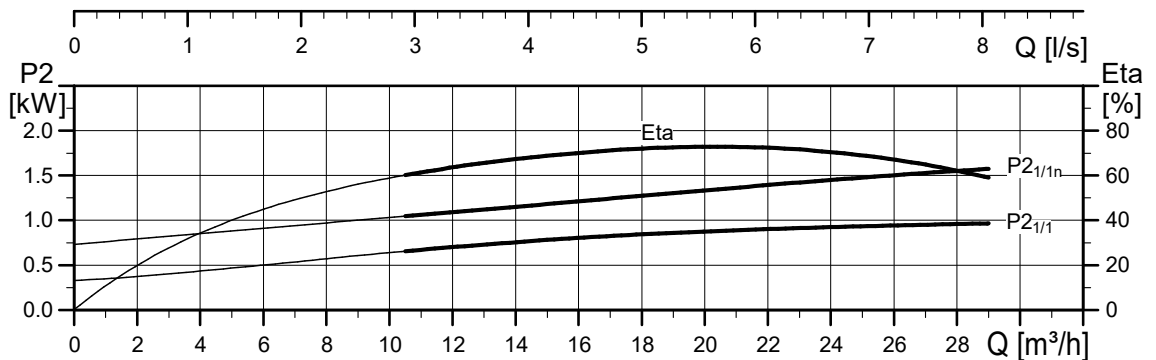
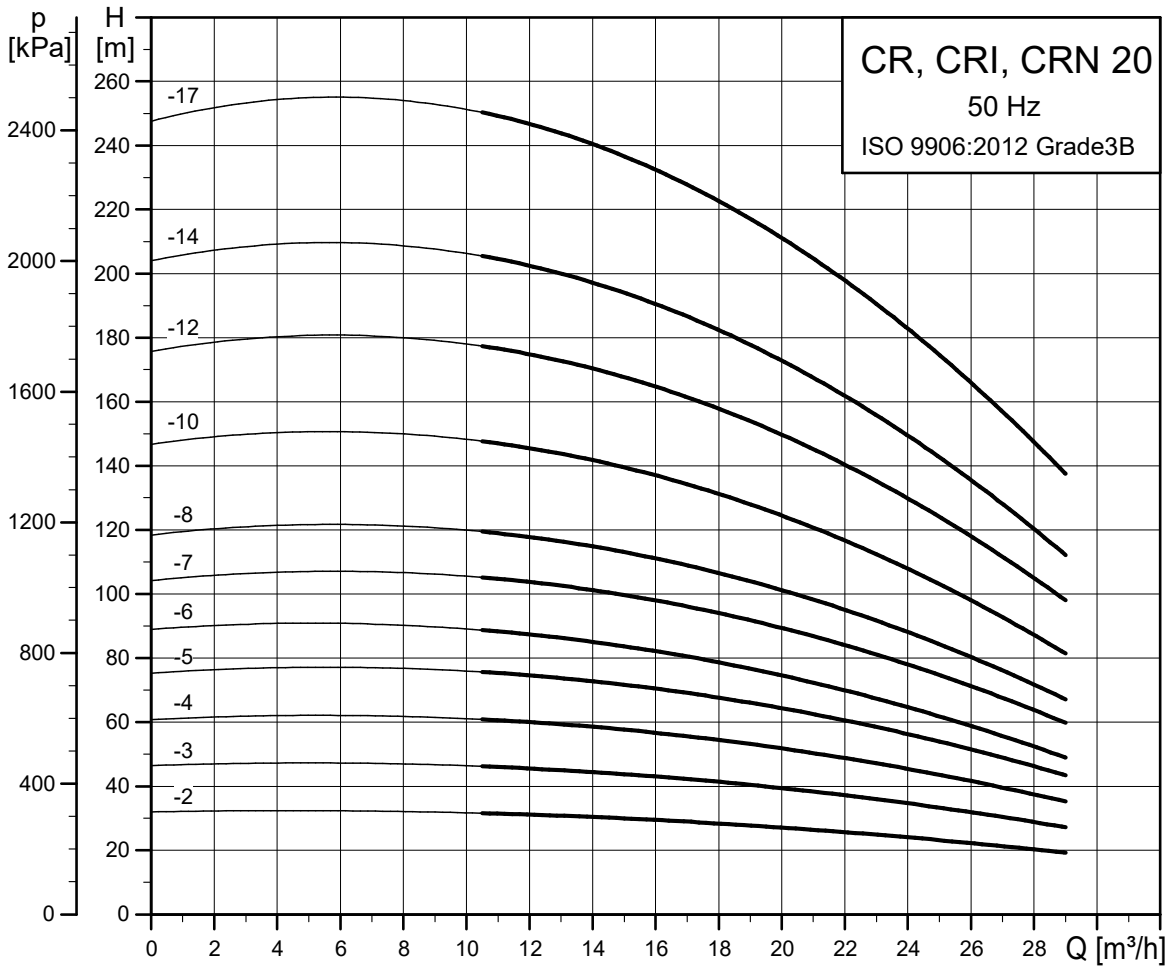

TM027393

Low-NPSH pumps with 2-pole motor, 50 Hz: CR, CRN 32

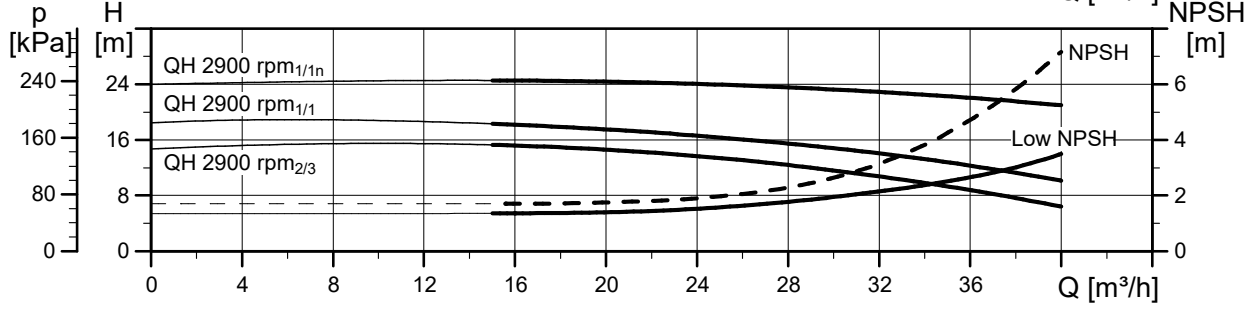
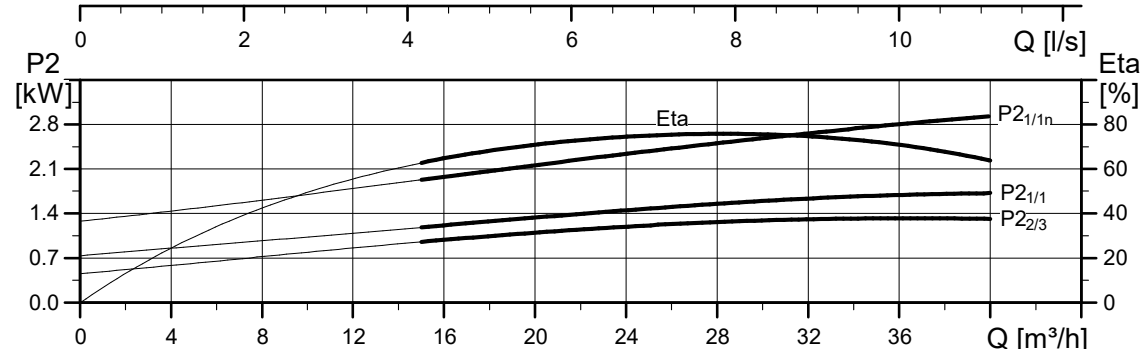
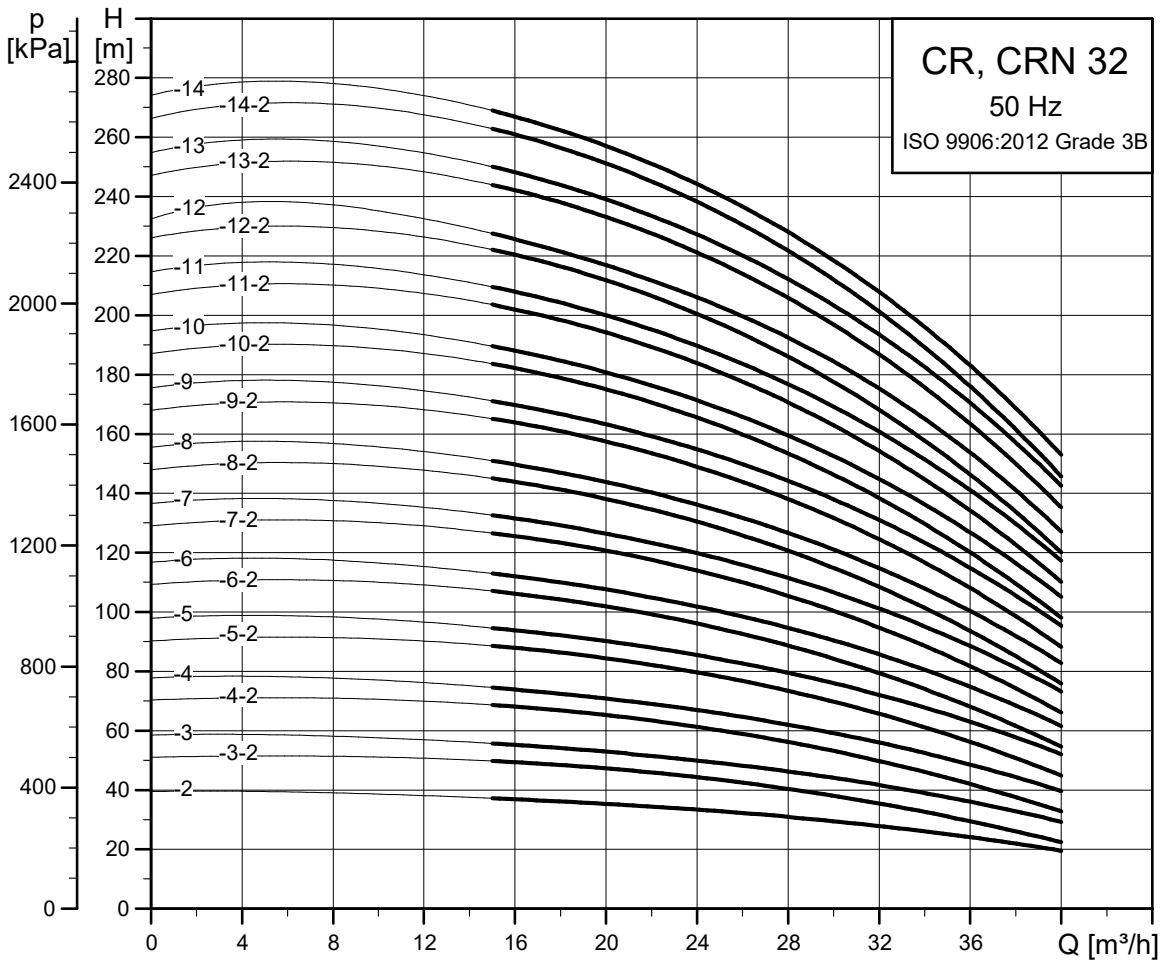

TM019129

Low-NPSH pumps with 2-pole motor, 50 Hz: CR, CRN 45

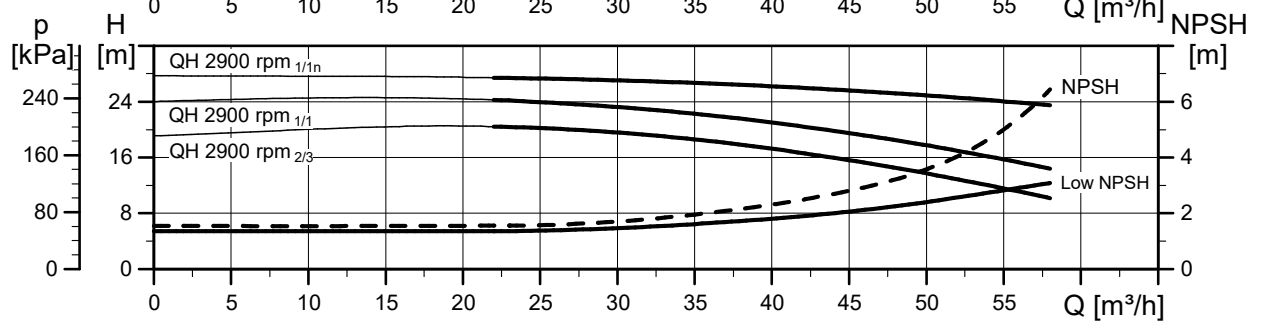
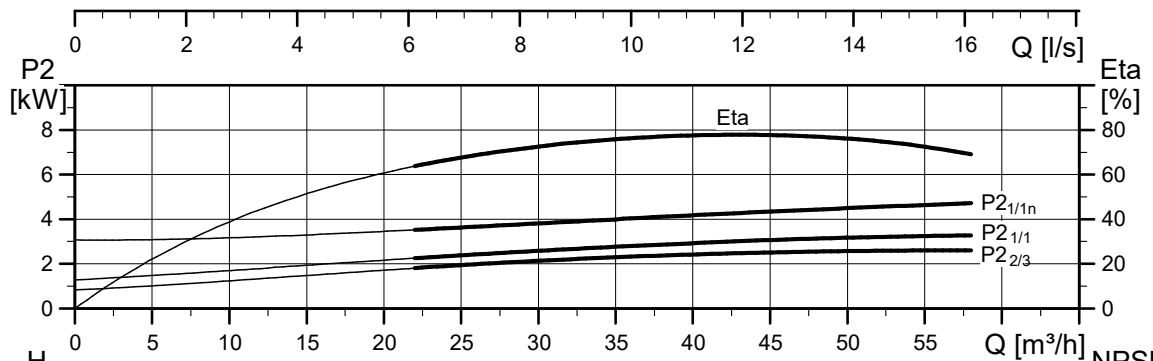
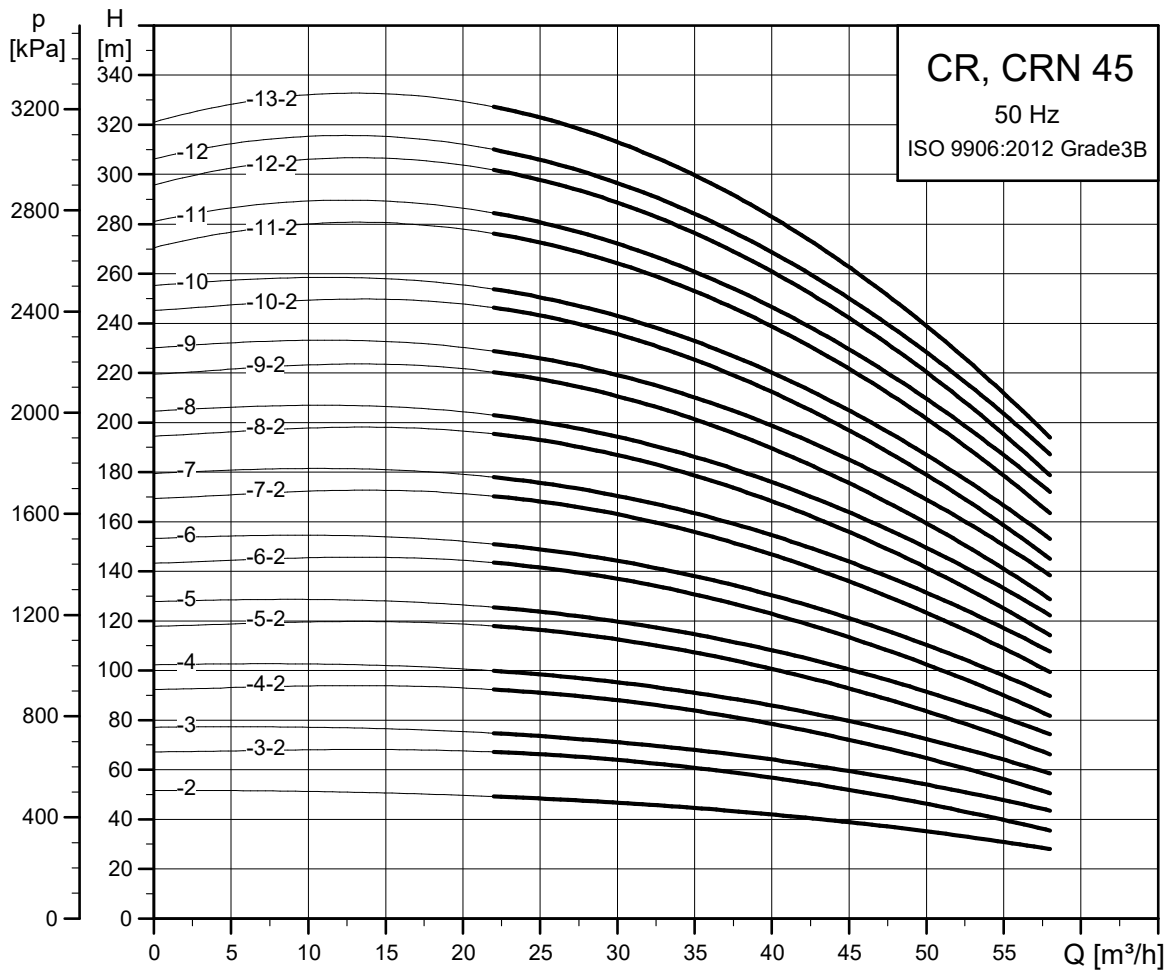

TMX11451

Low-NPSH pumps with 2-pole motor, 50 Hz: CR, CRN 64

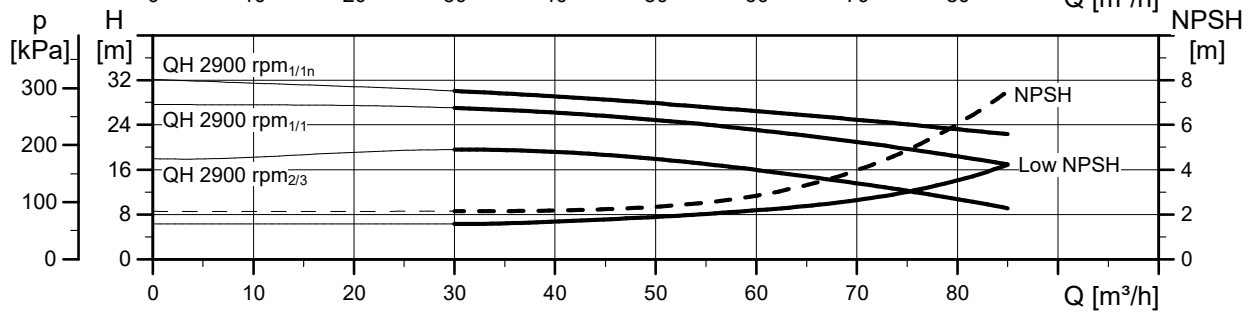
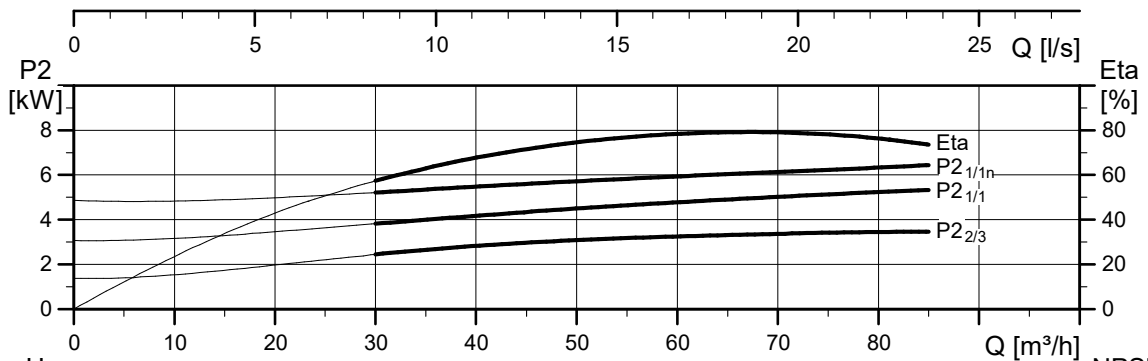
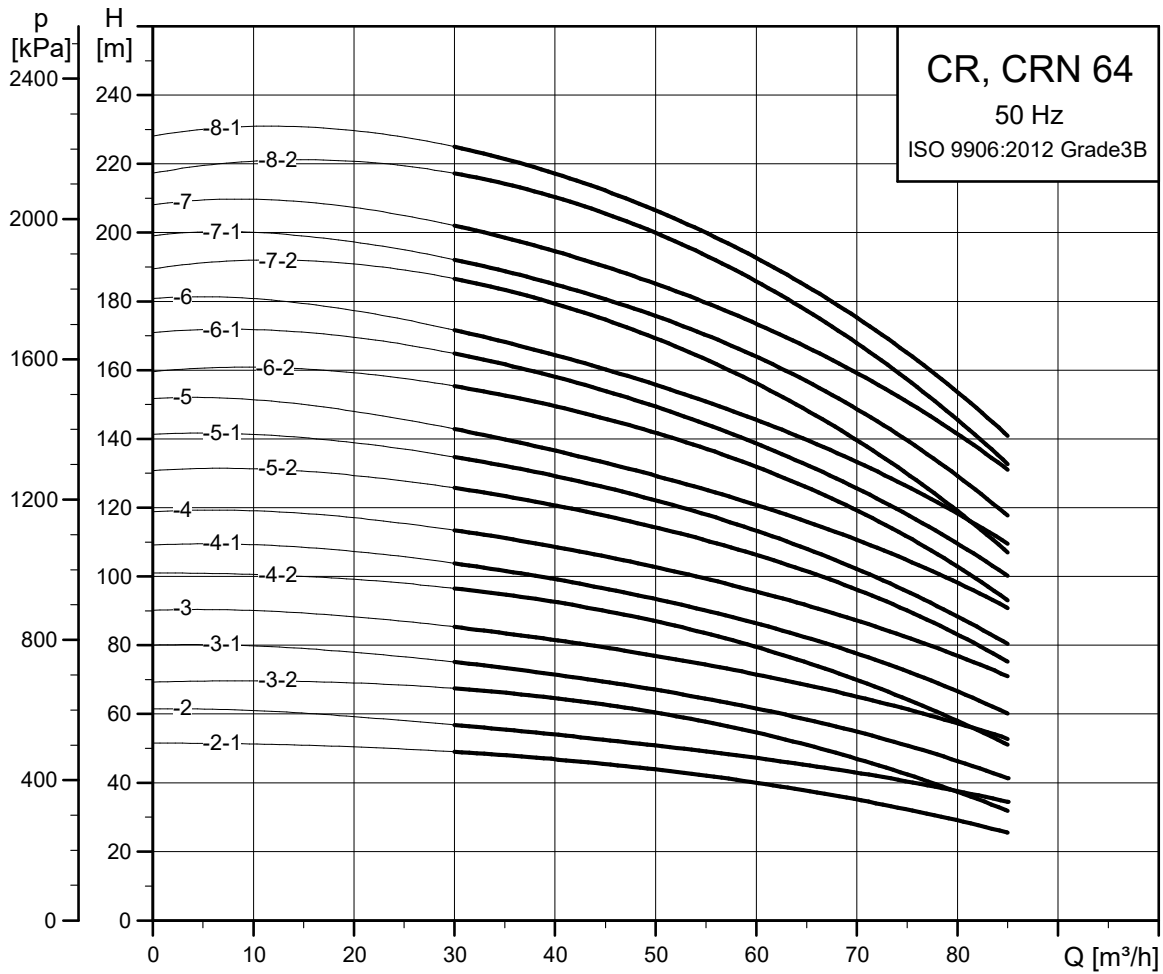

TM020753

Low-NPSH pumps, 60 Hz

Low-NPSH pumps with 2-pole motor, 60 Hz: CR, CRI, CRN 3

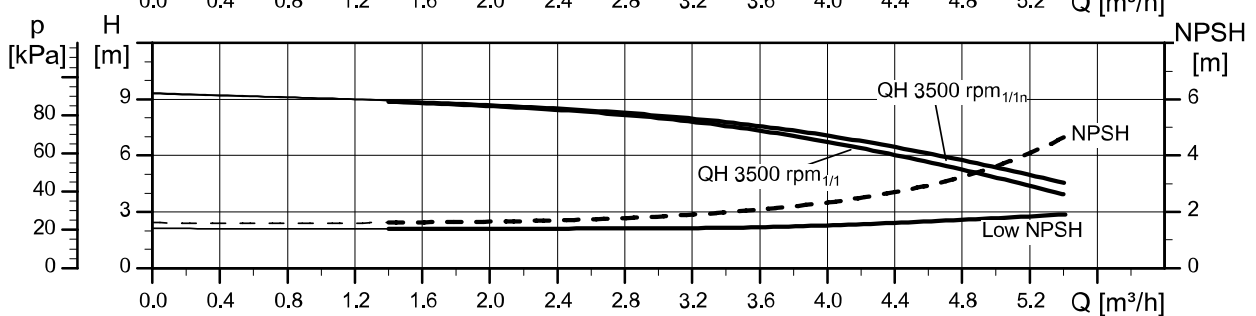
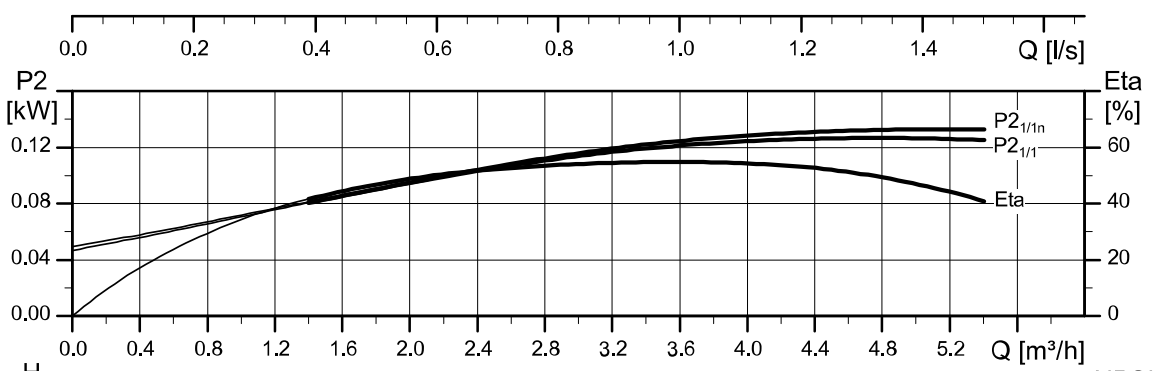
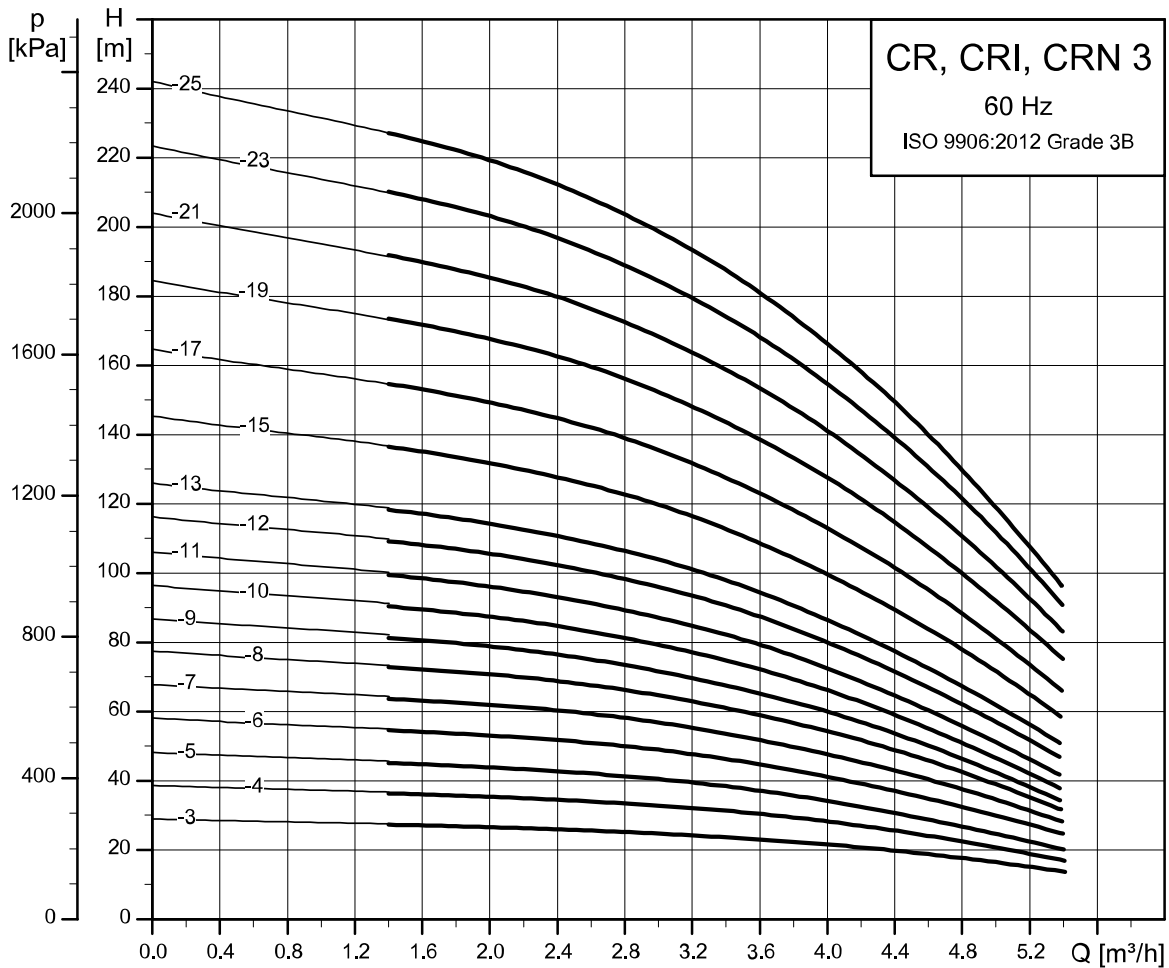

TM022574

Low-NPSH pumps with 2-pole motor, 60 Hz: CR, CRI, CRN 5

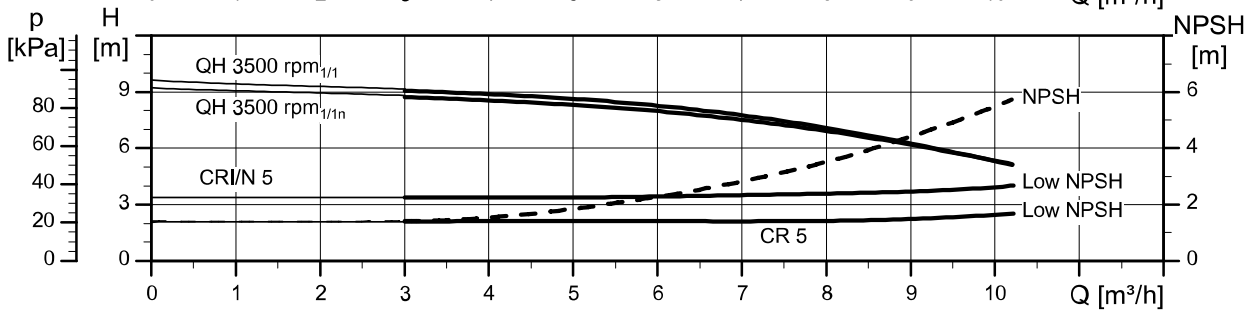
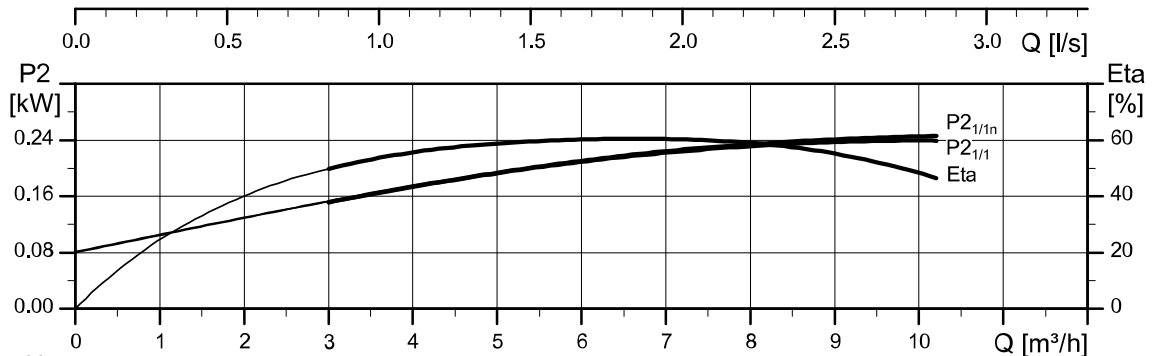
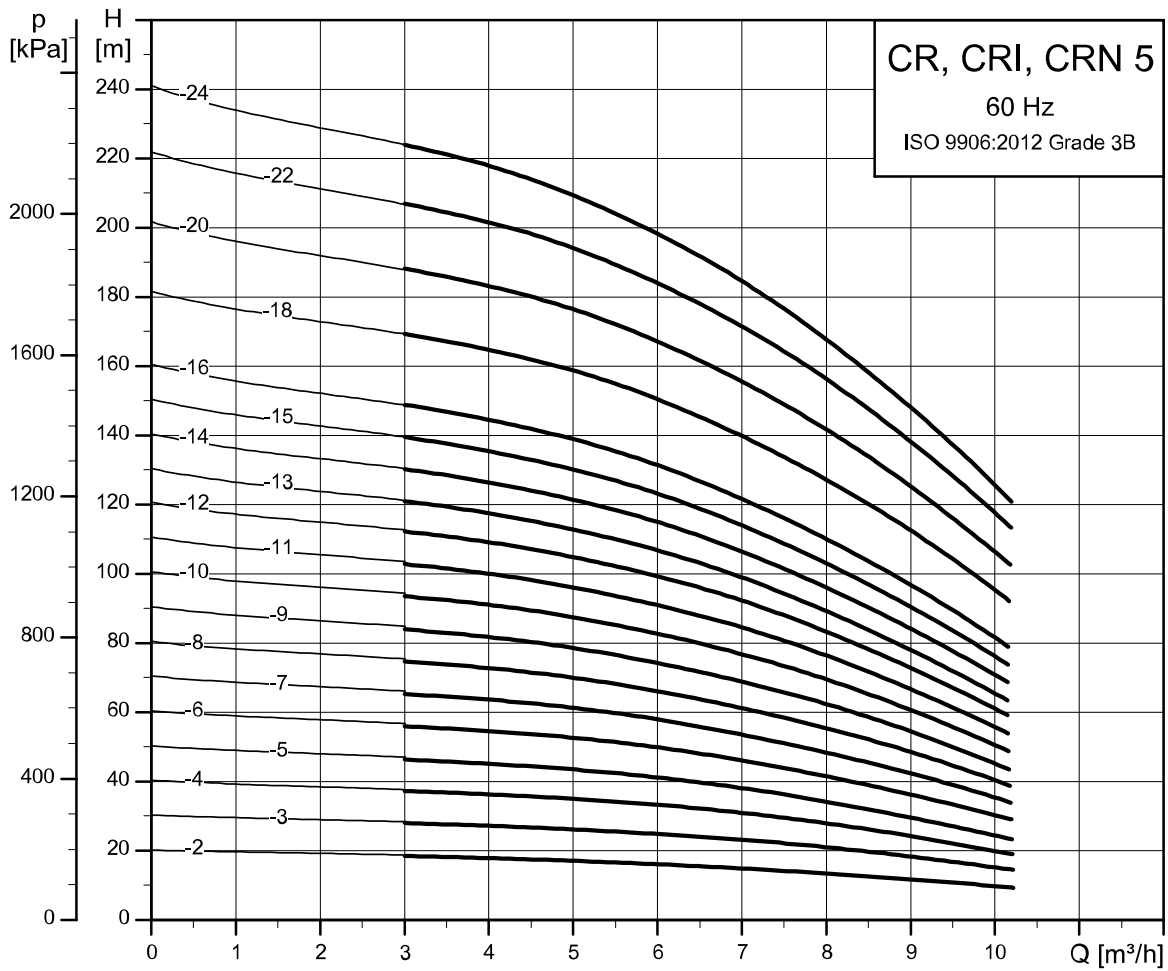

TM022575

Low-NPSH pumps with 2-pole motor, 60 Hz: CR, CRI, CRN 10

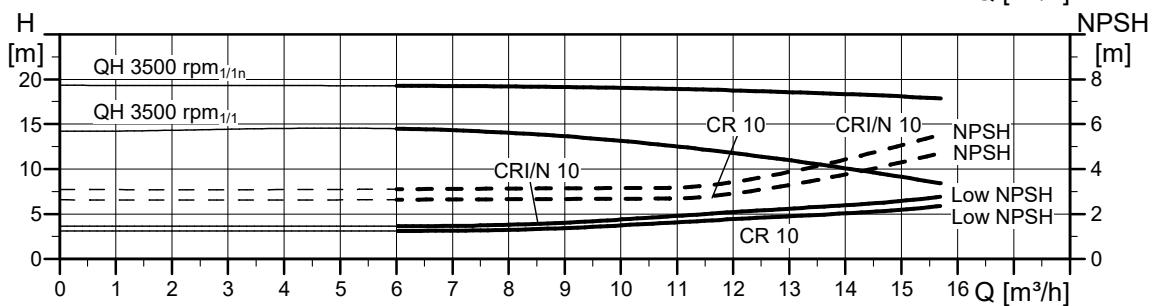
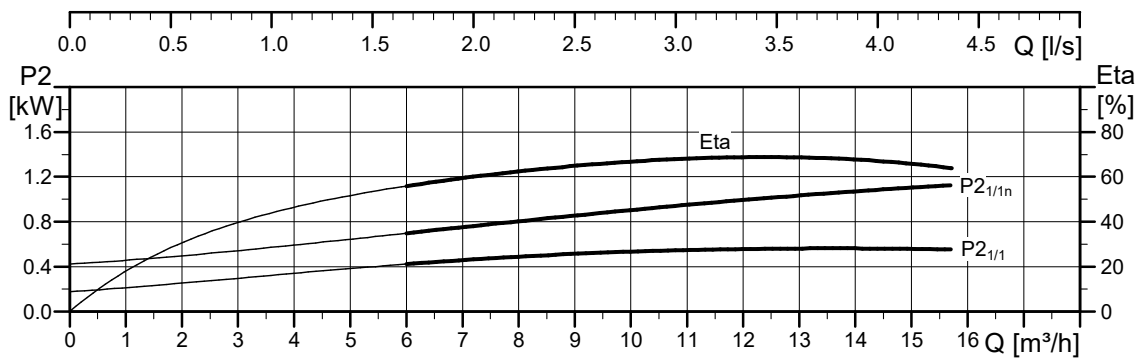
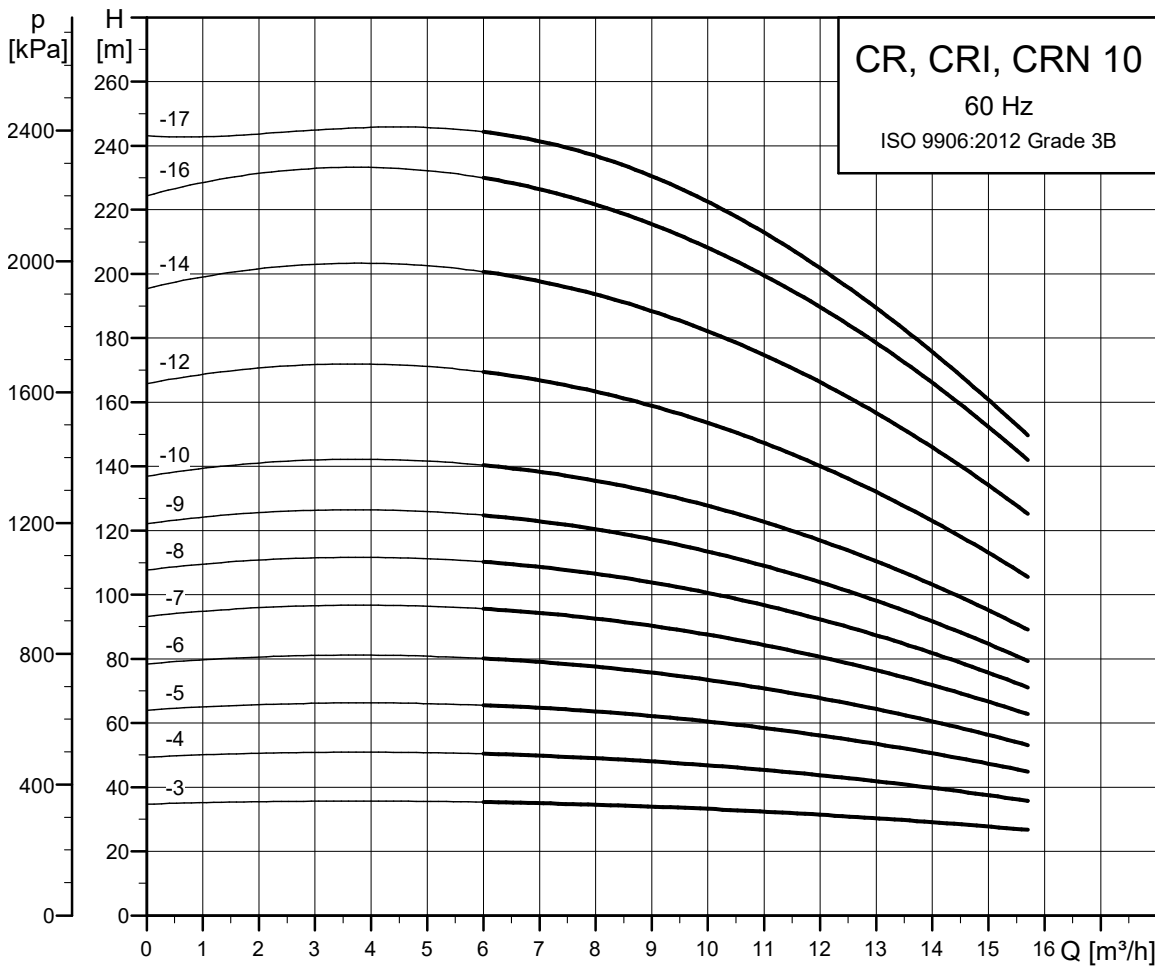

TM027394

Low-NPSH pumps with 2-pole motor, 60 Hz: CR, CRI, CRN 15

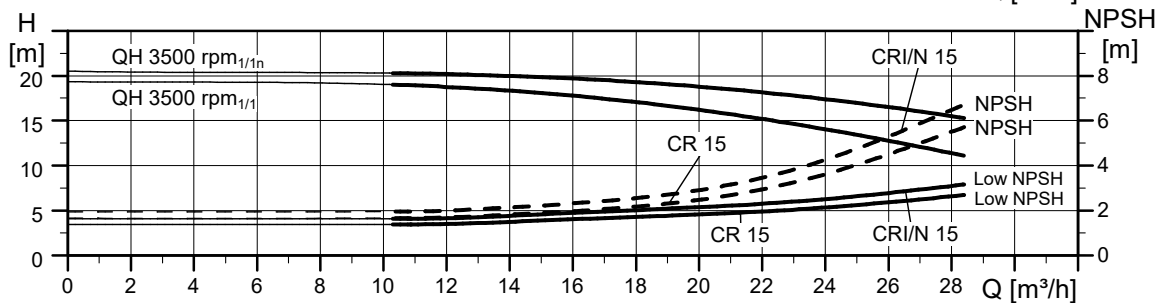
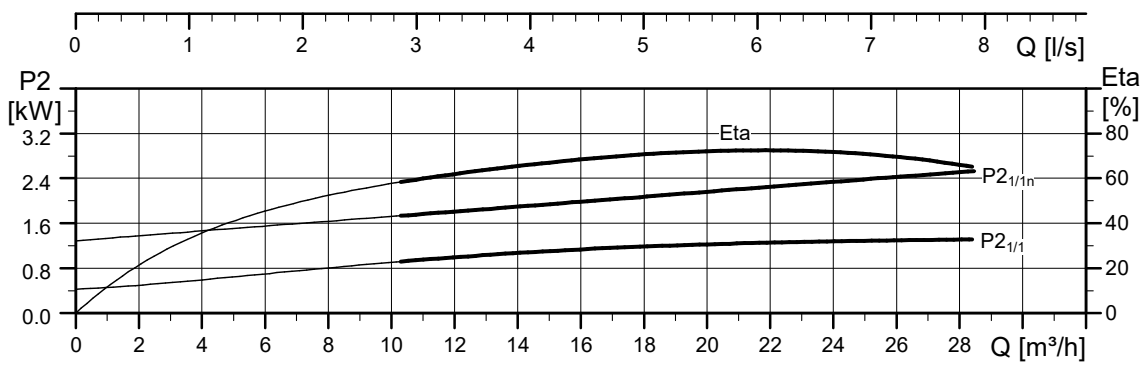
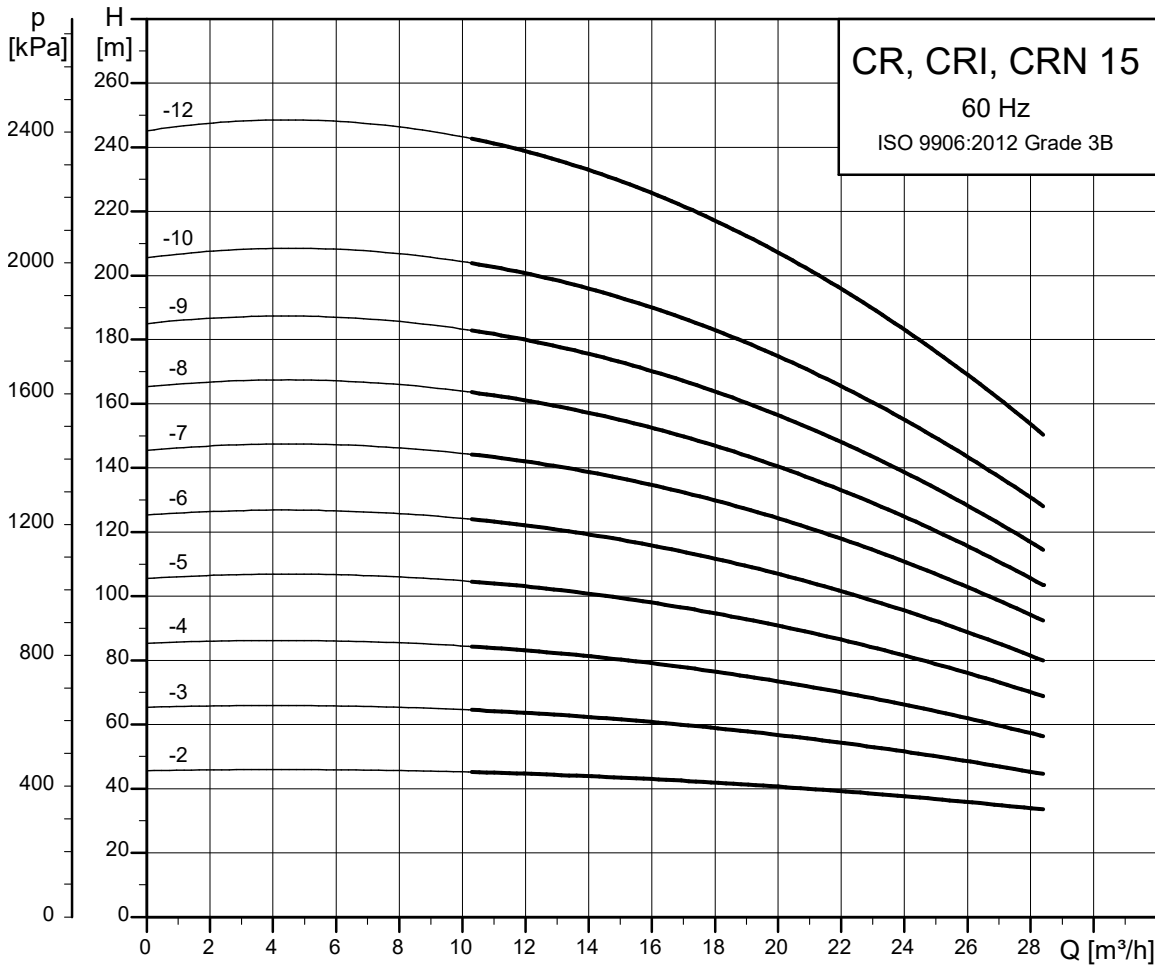

TM027395

Low-NPSH pumps with 2-pole motor, 60 Hz: CR, CRI, CRN 20

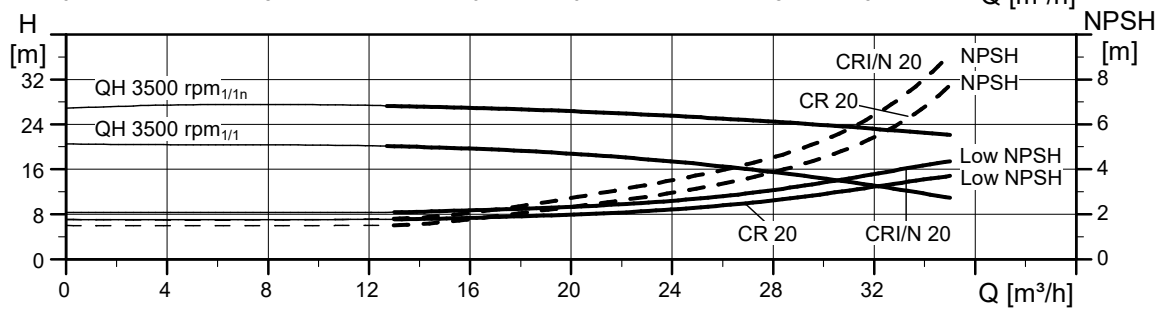
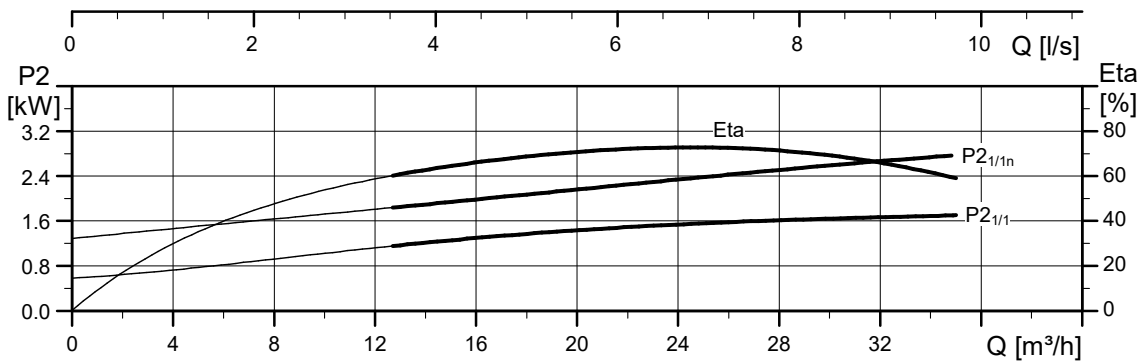
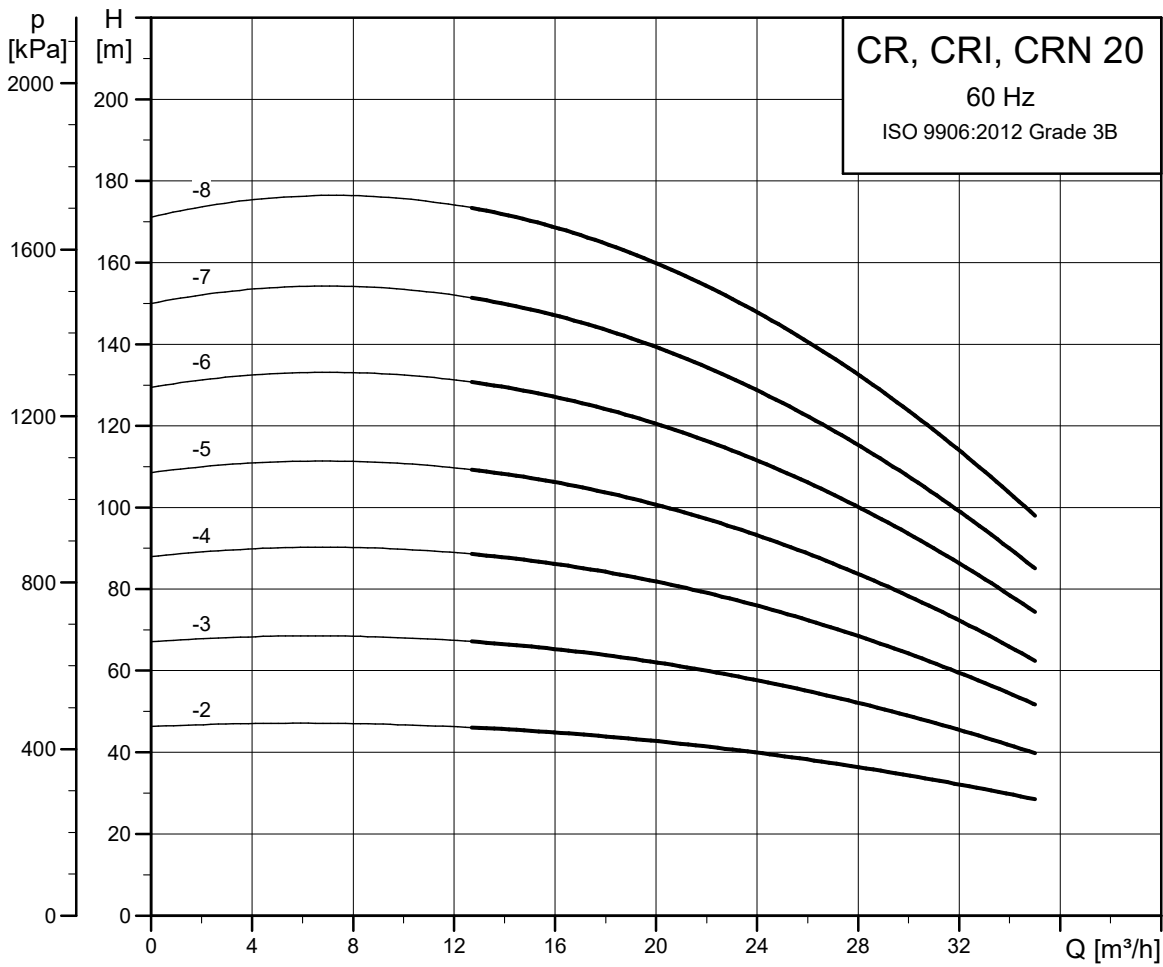

TM027396

Low-NPSH pumps with 2-pole motor, 60 Hz: CR, CRN 32

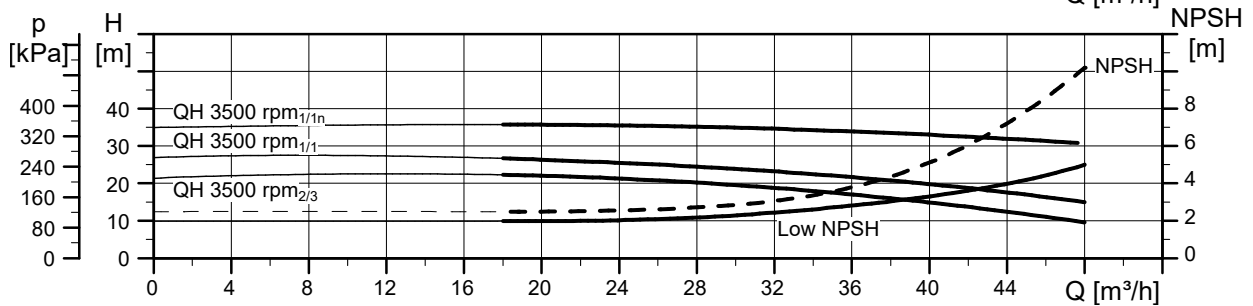
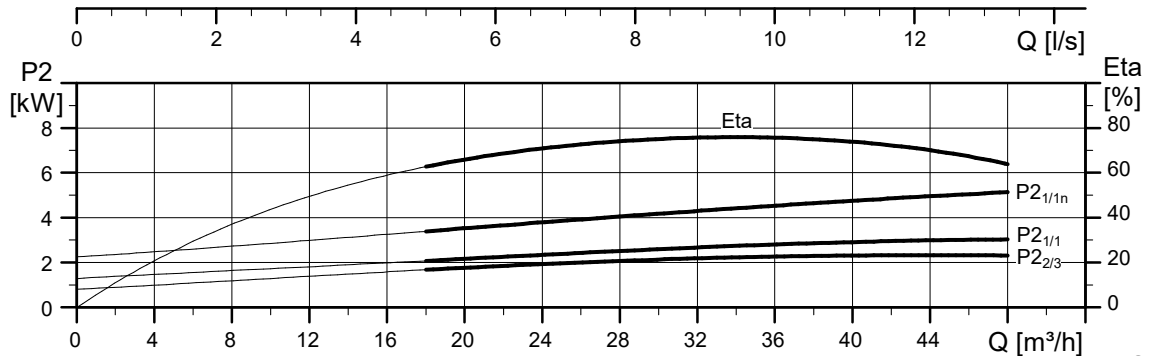
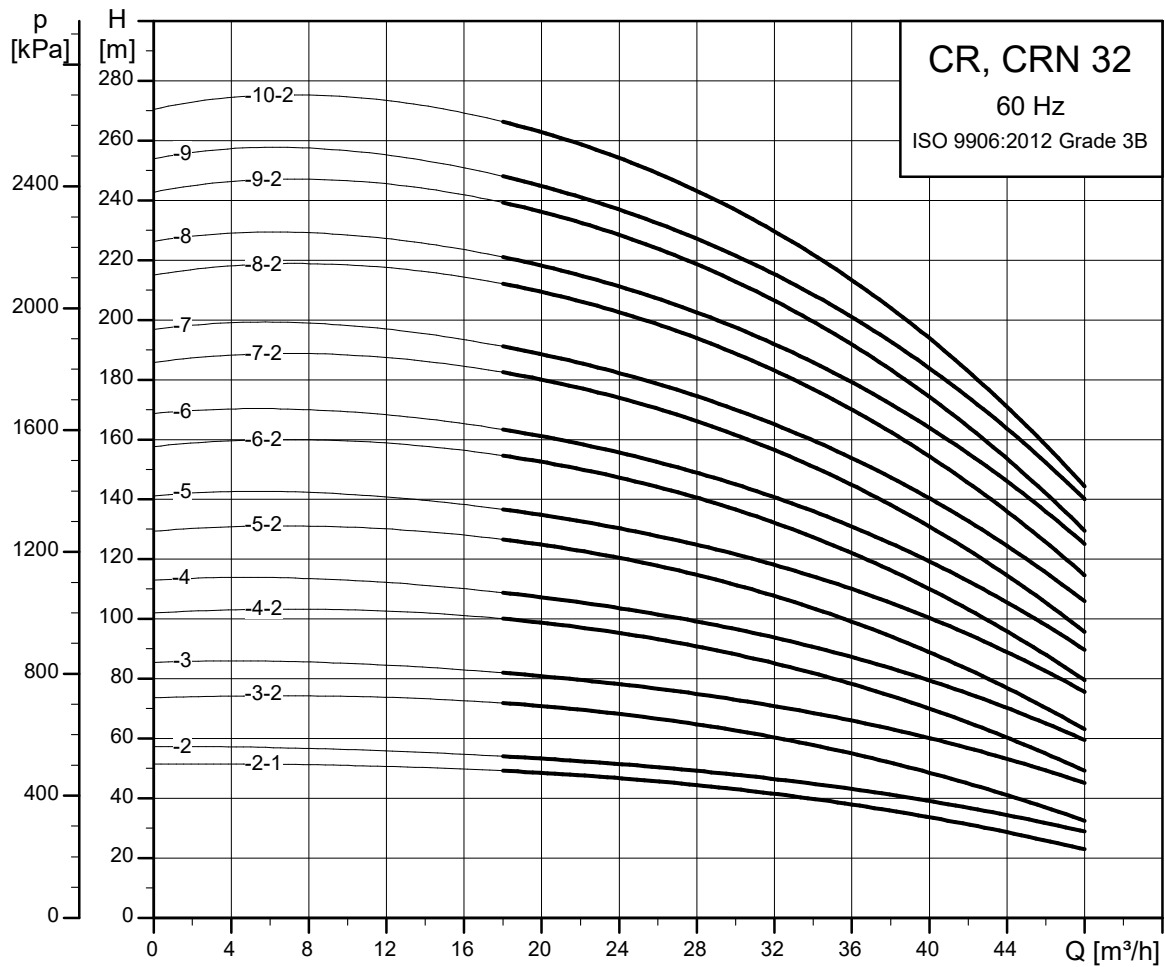

TM022578

Low-NPSH pumps with 2-pole motor, 60 Hz: CR, CRN 45

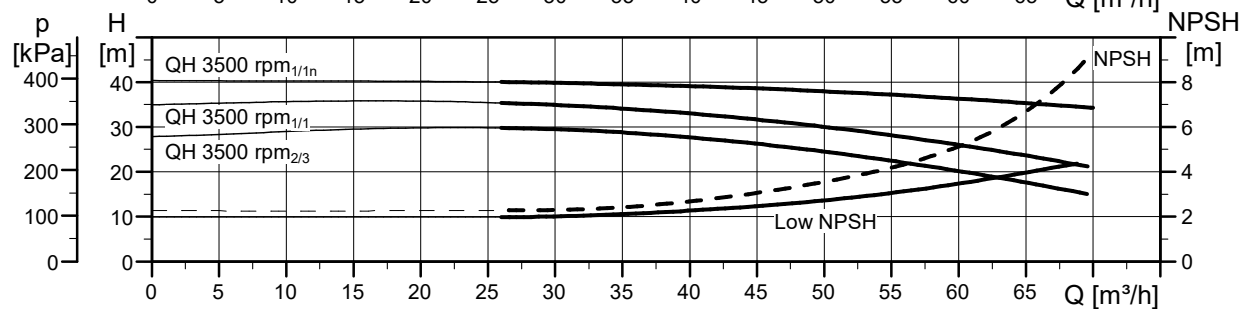
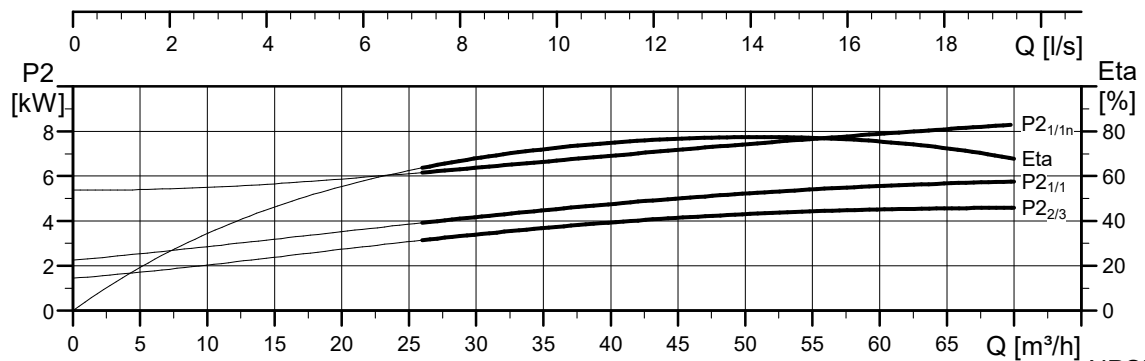
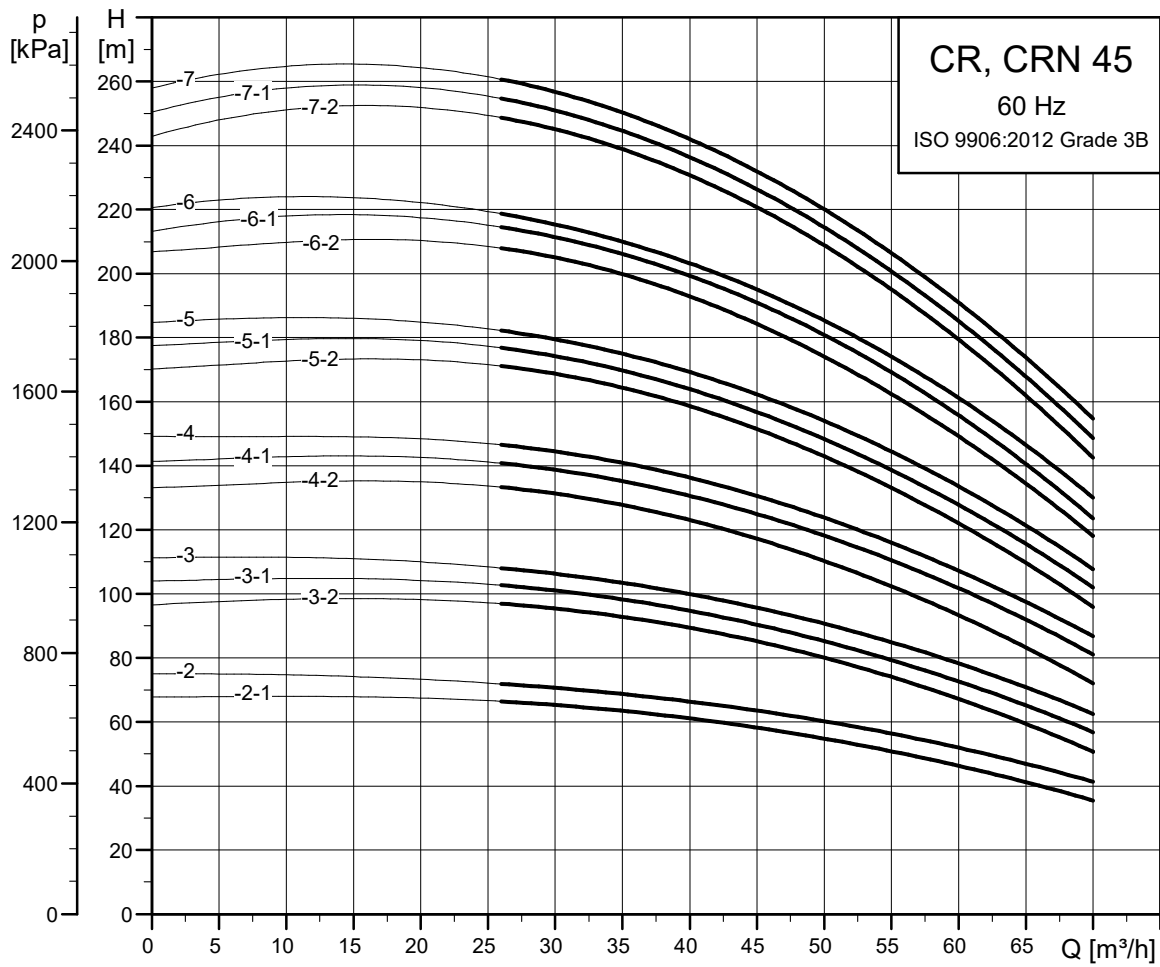

TM022579

Low-NPSH pumps with 2-pole motor, 60 Hz: CR, CRN 64

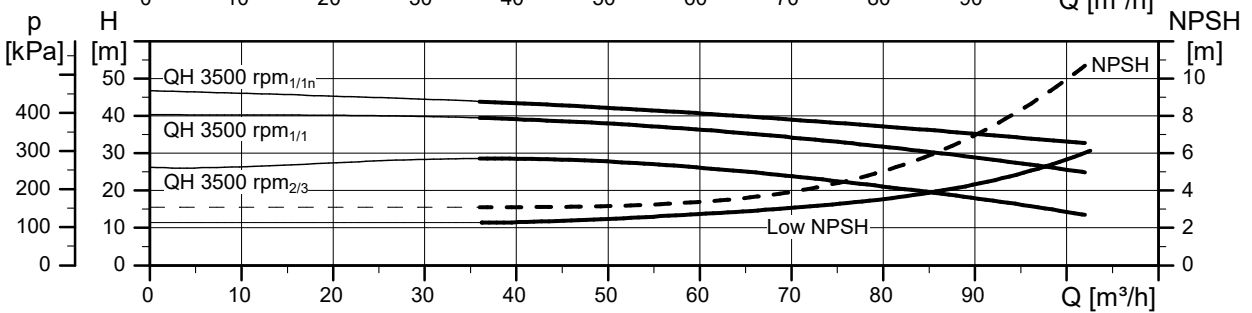
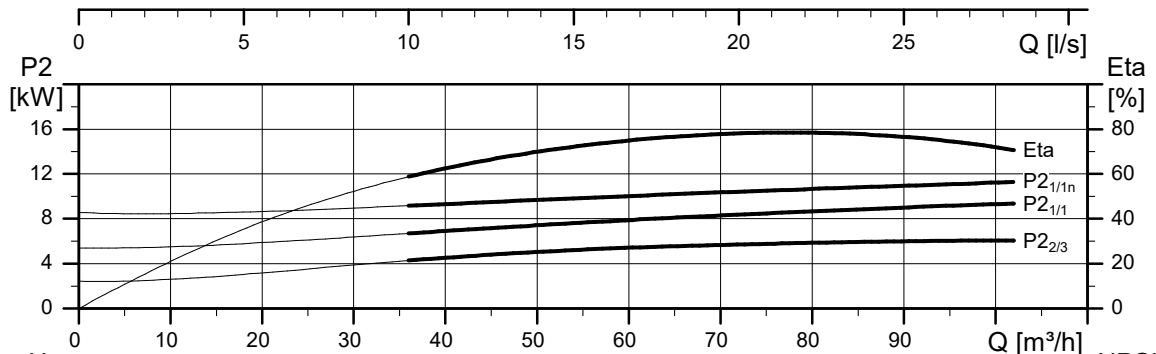
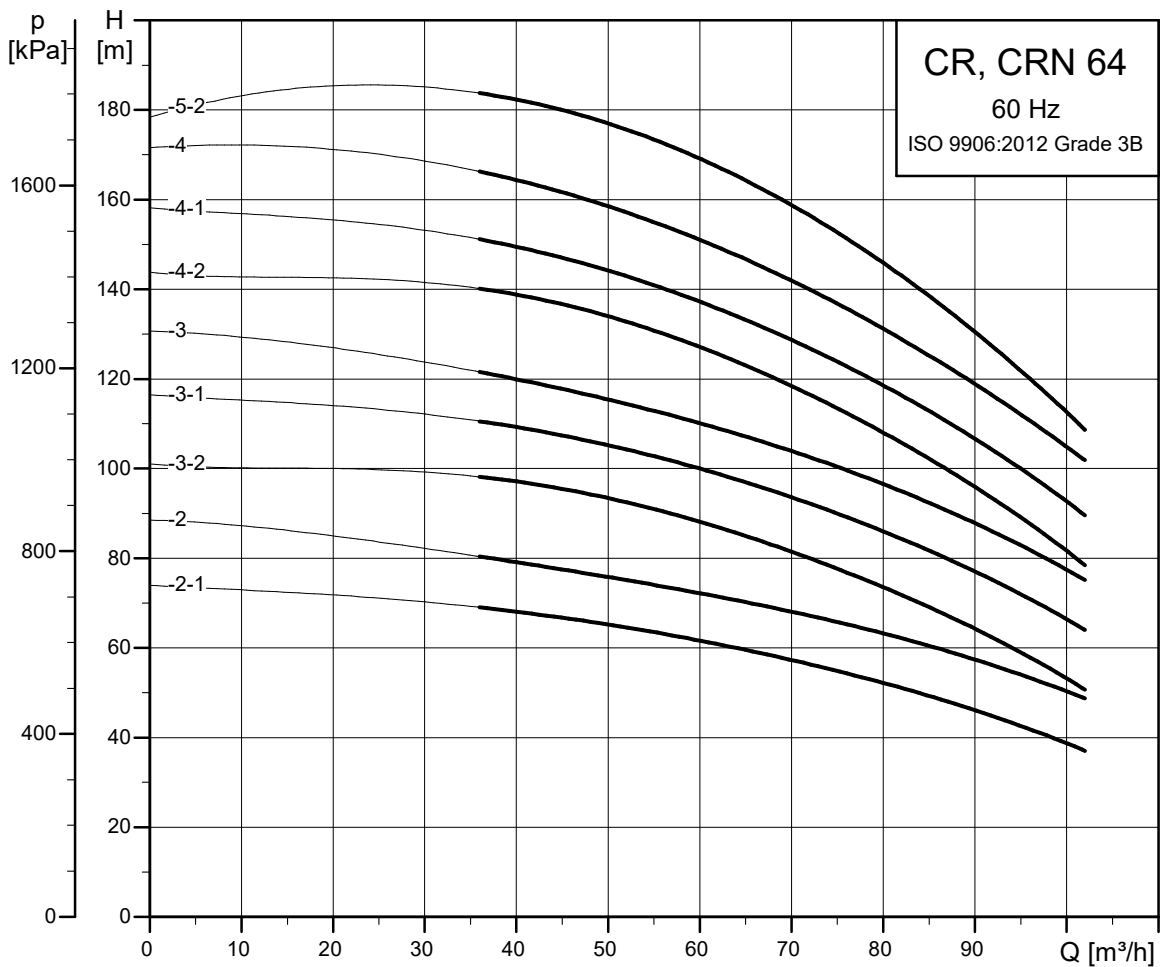

TM022580

CR pumps with 4-pole motor, 50 Hz

CR pumps with 4-pole motor, 50 Hz: CR, CRI, CRN 1

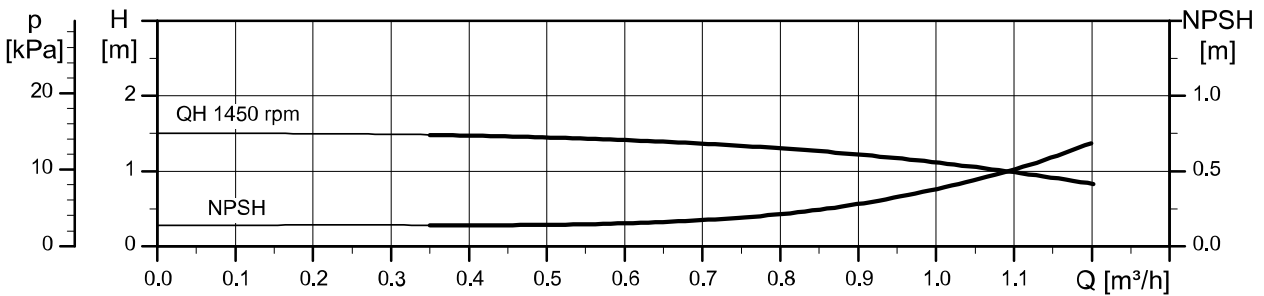
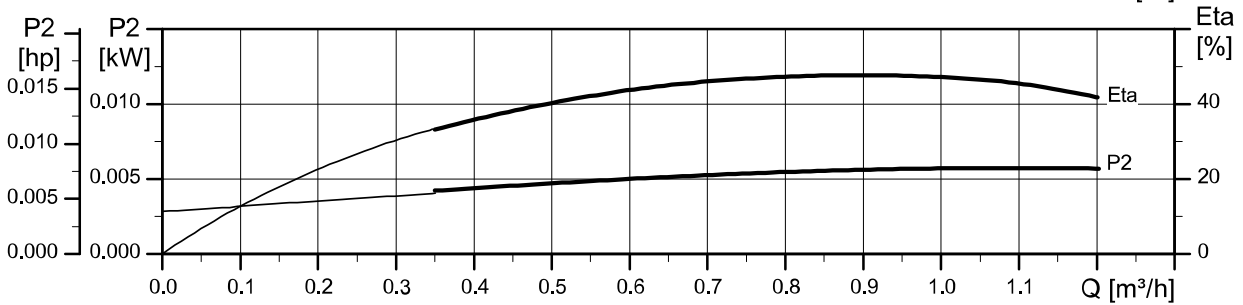
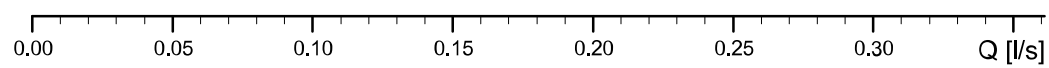
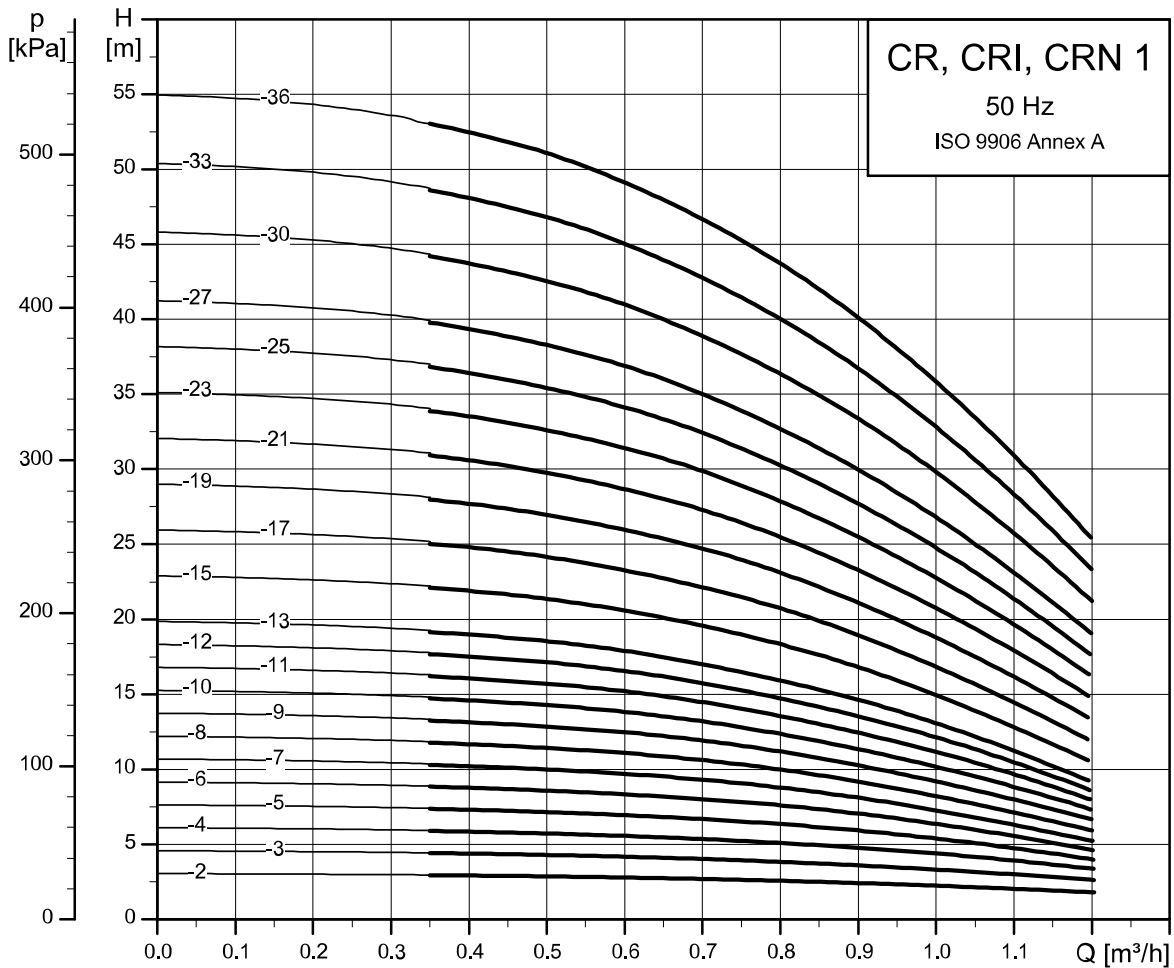

TM022543

CR pumps with 4-pole motor, 50 Hz: CR, CRI, CRN 3

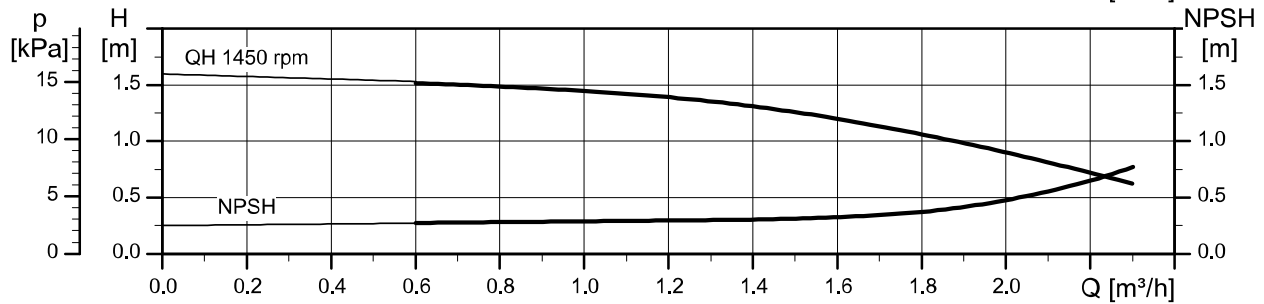
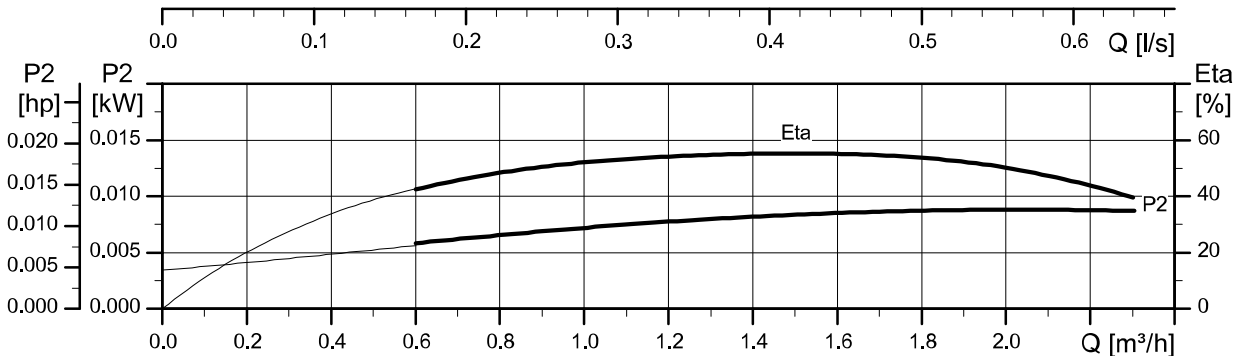
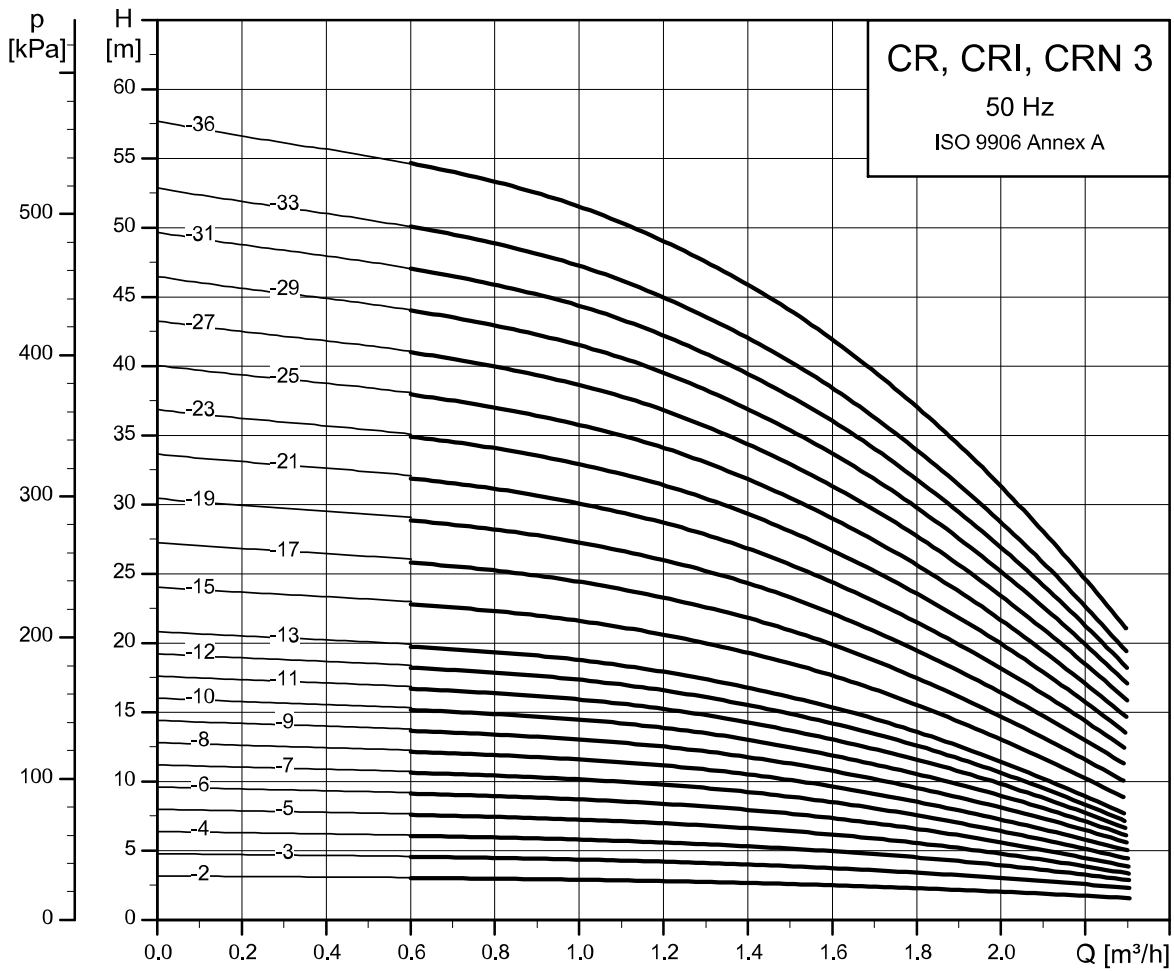

TM022542

CR pumps with 4-pole motor, 50 Hz: CR, CRI, CRN 5

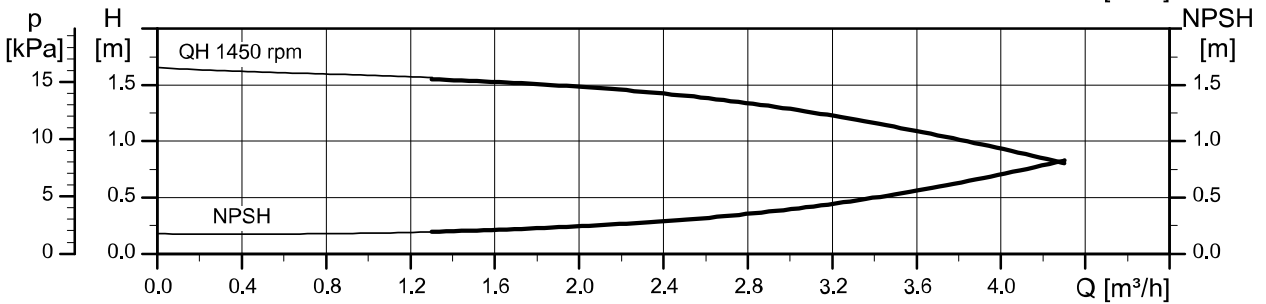
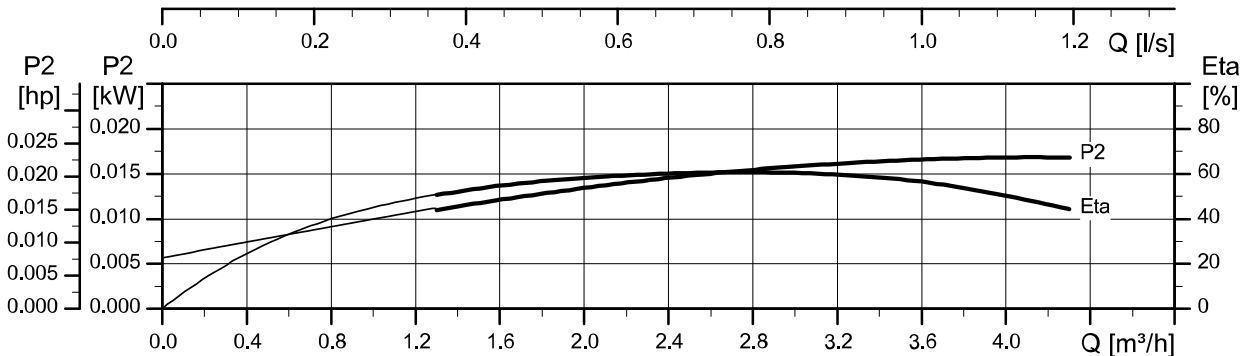
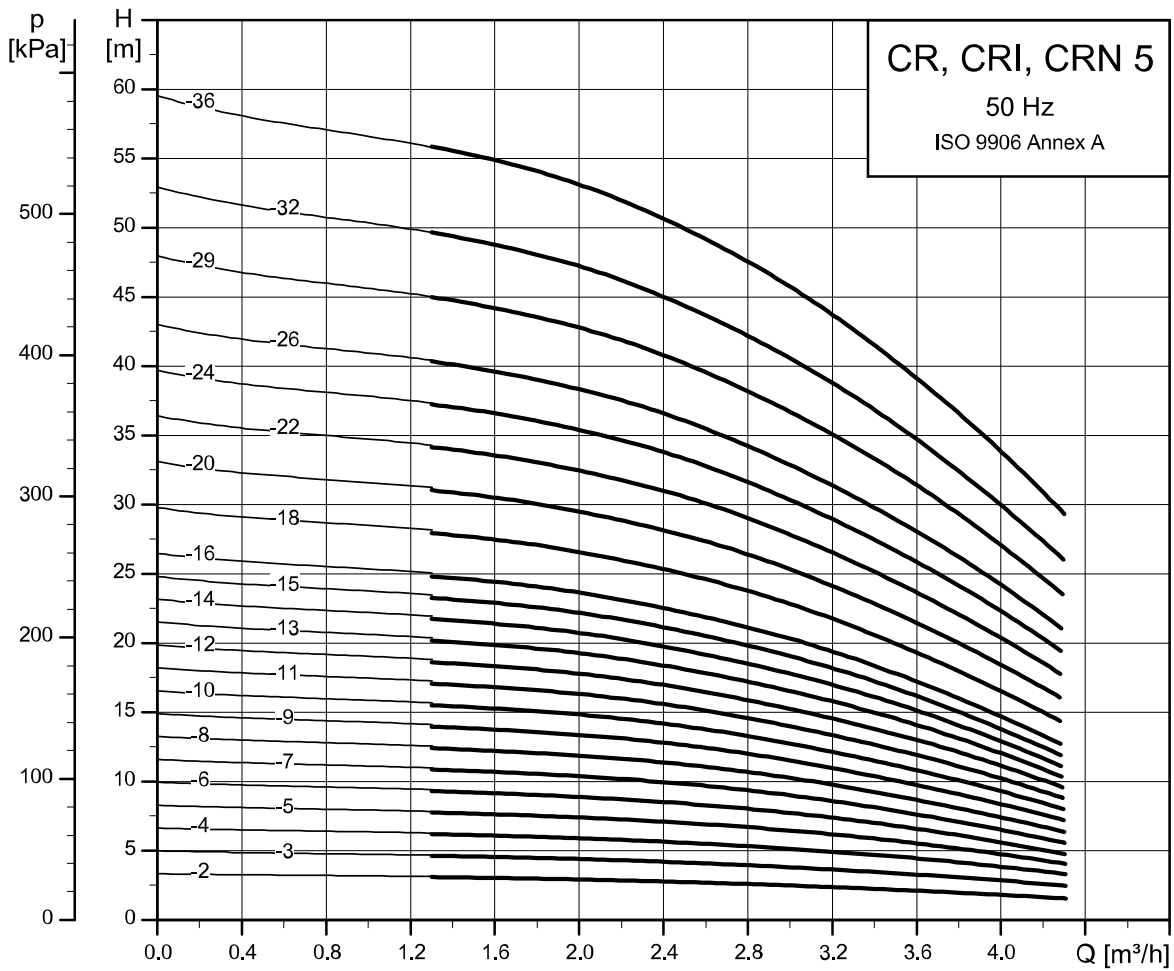

TM022541

CR pumps with 4-pole motor, 50 Hz: CR, CRI, CRN 10

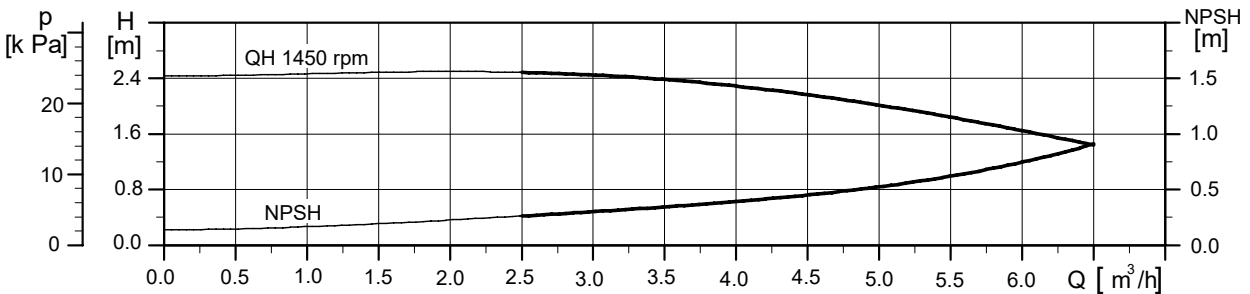
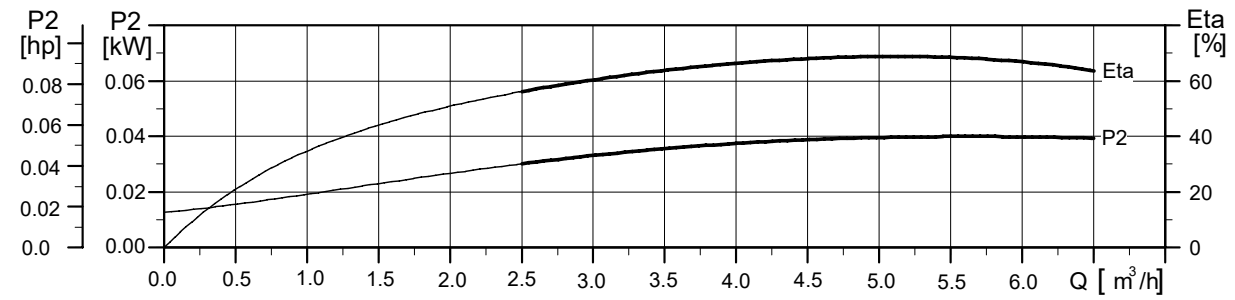
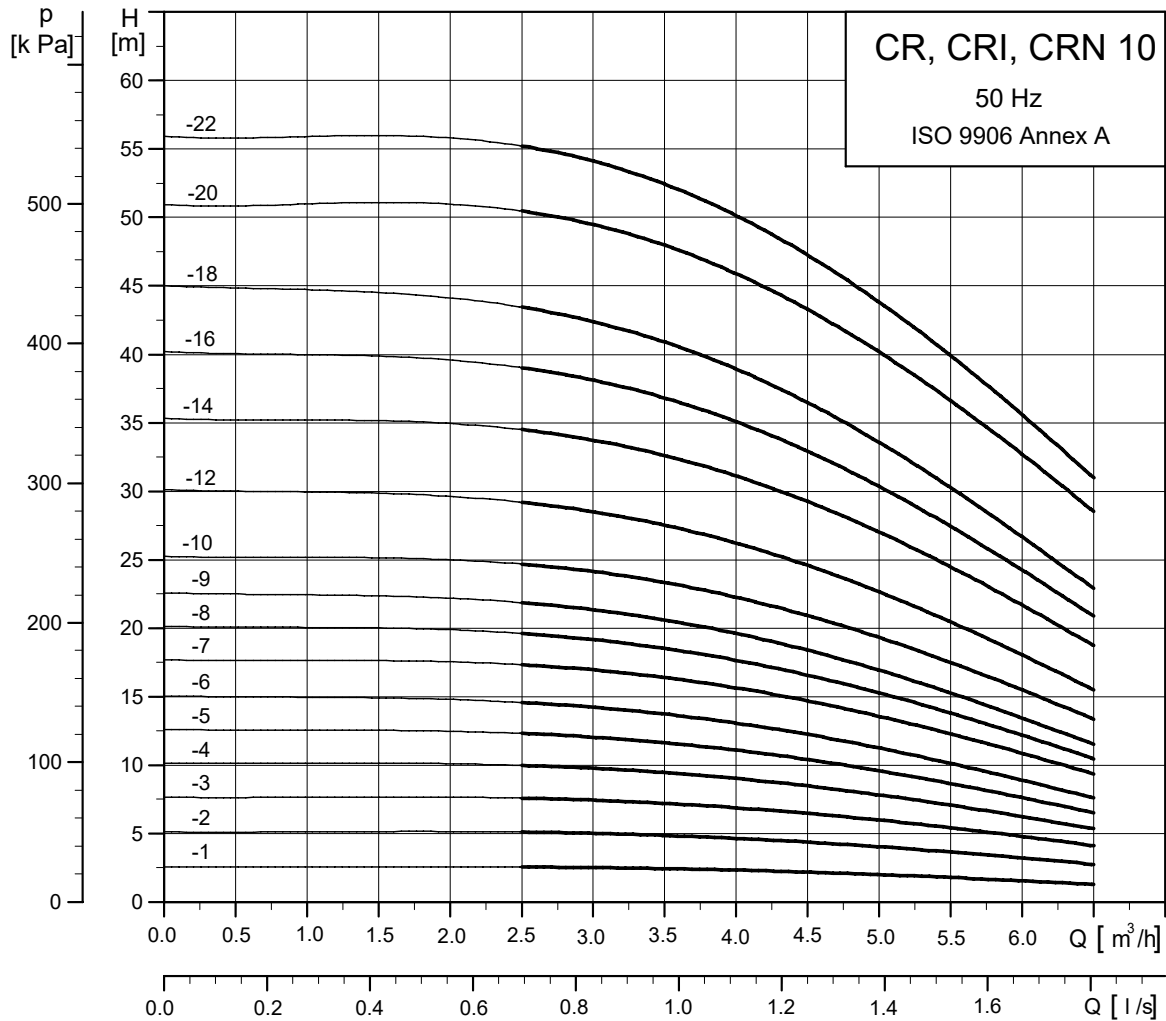

TM027273

CR pumps with 4-pole motor, 50 Hz: CR, CRI, CRN 15

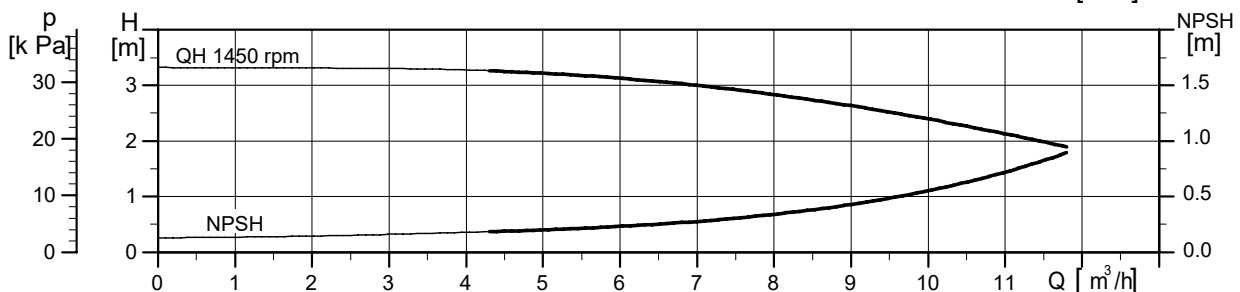
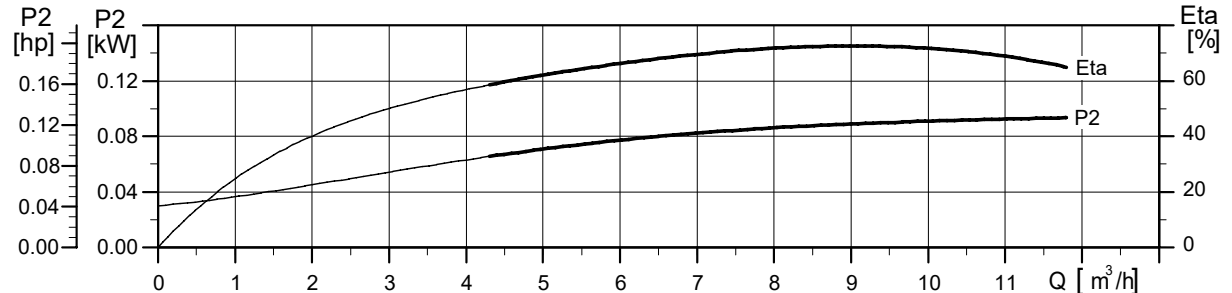
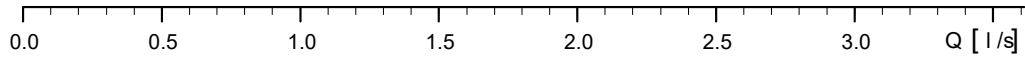
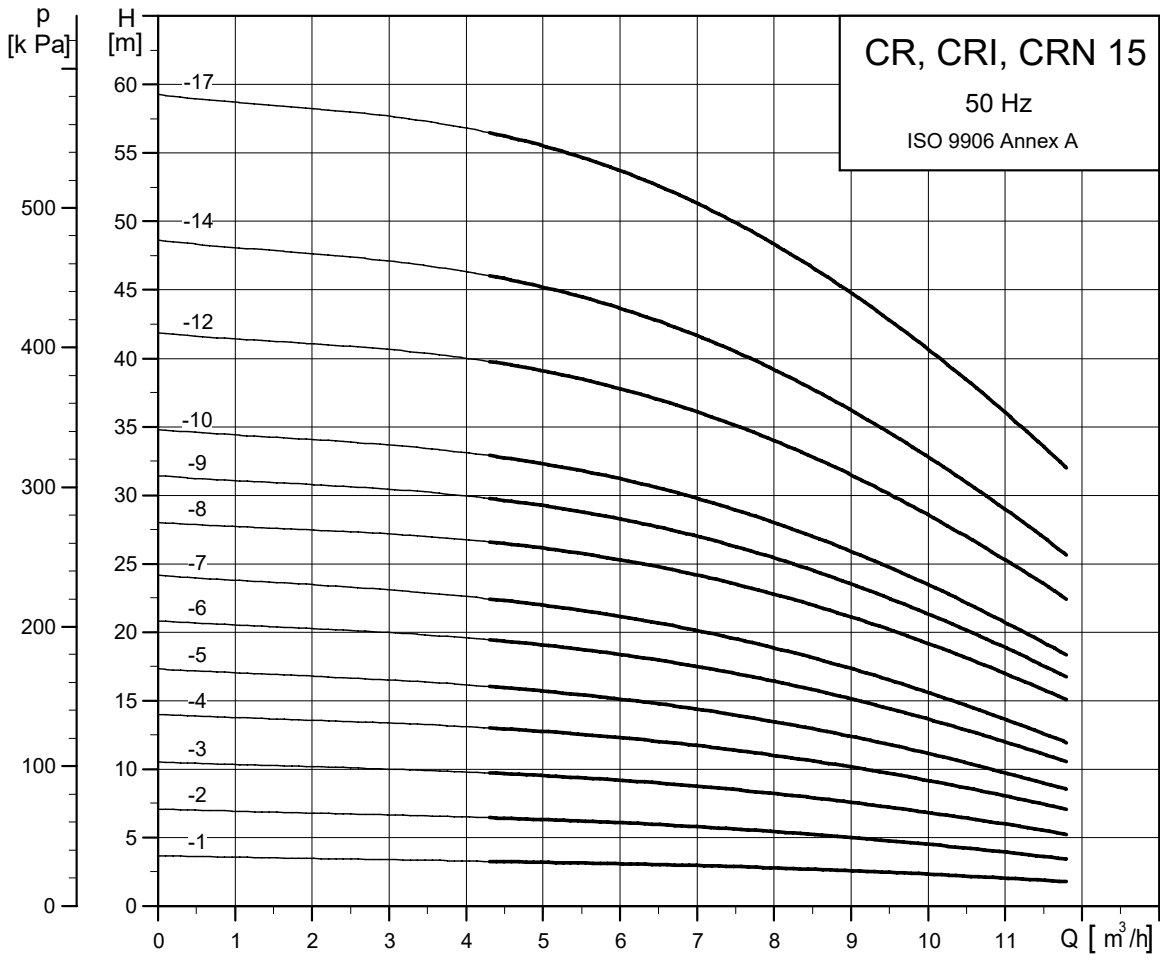

TM027274

CR pumps with 4-pole motor, 50 Hz: CR, CRI, CRN 20

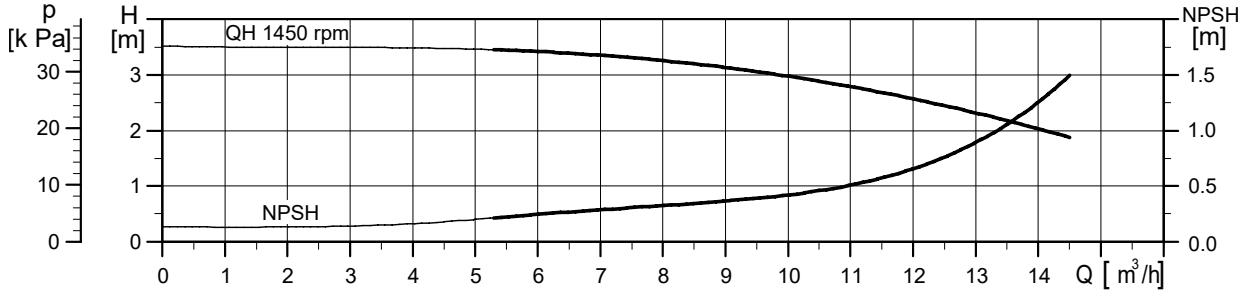
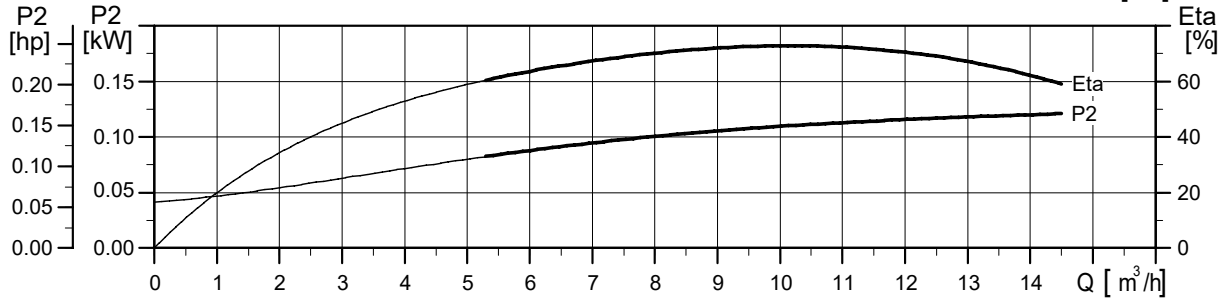
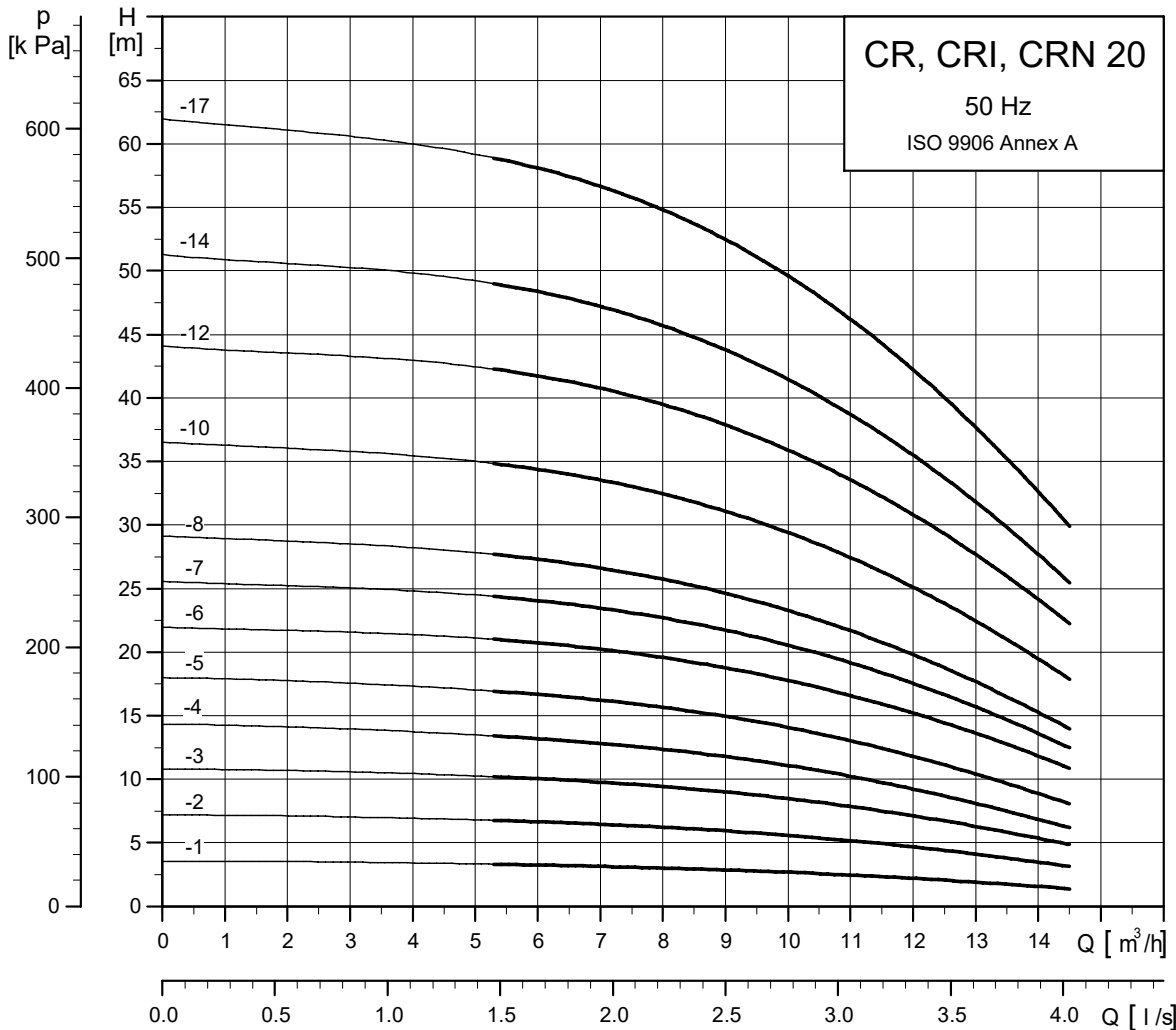

TM027275

CR pumps with 4-pole motor, 50 Hz: CR, CRN 32

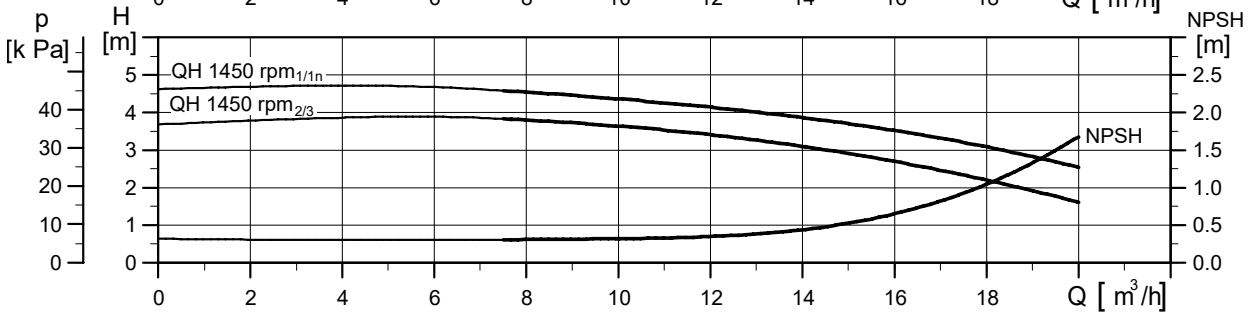
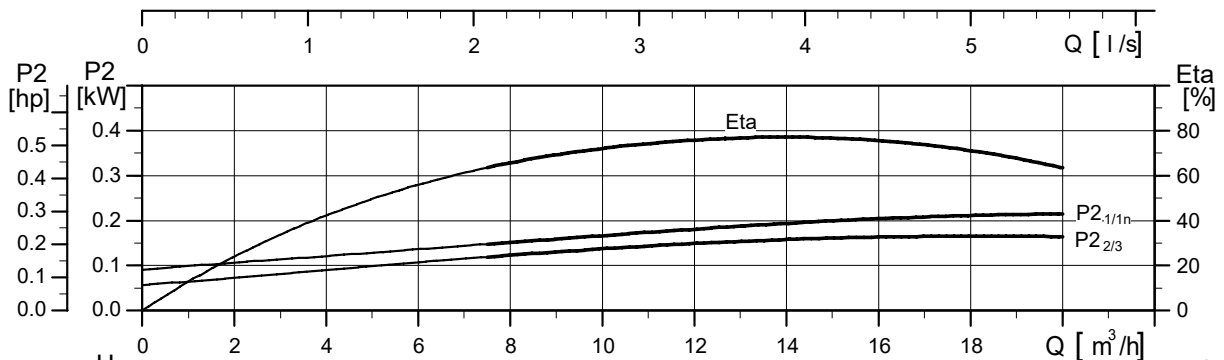
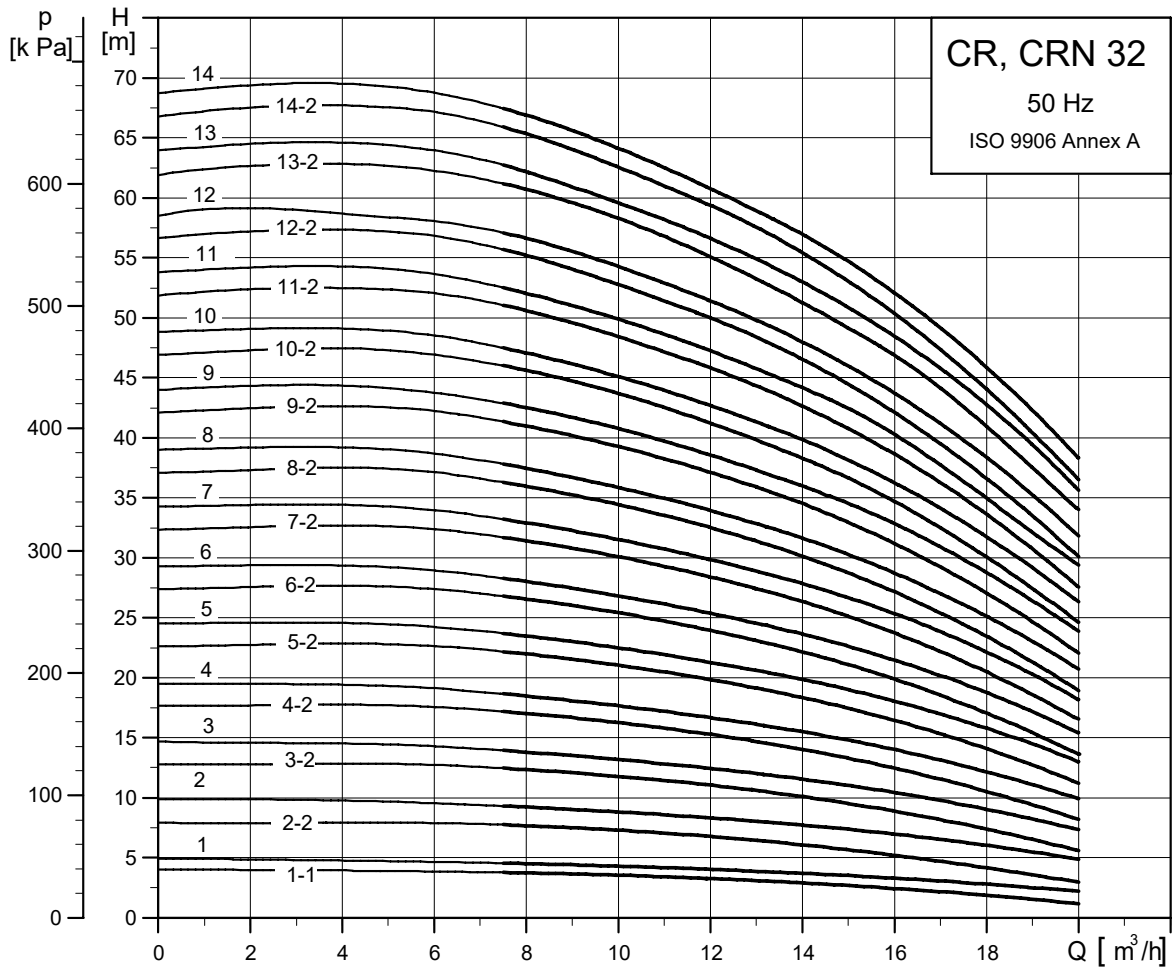

TMO18153

CR pumps with 4-pole motor, 50 Hz: CR, CRN 45

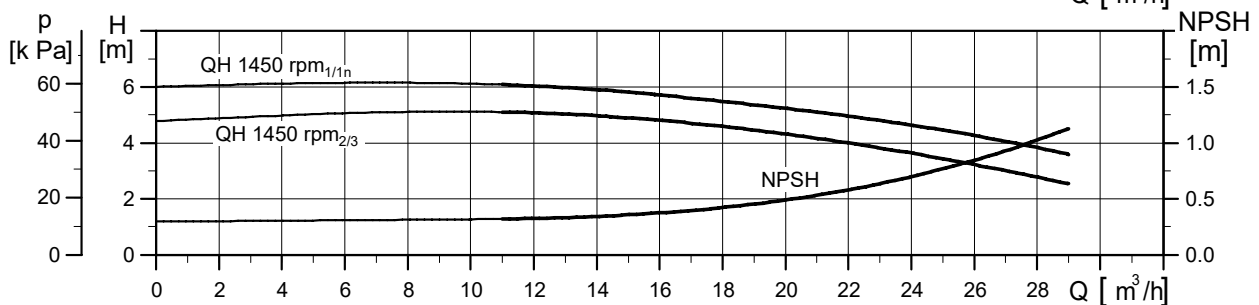
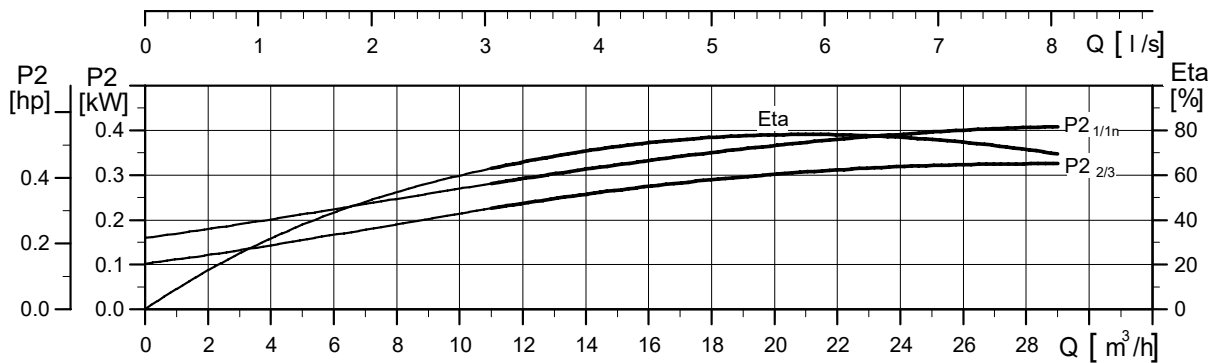
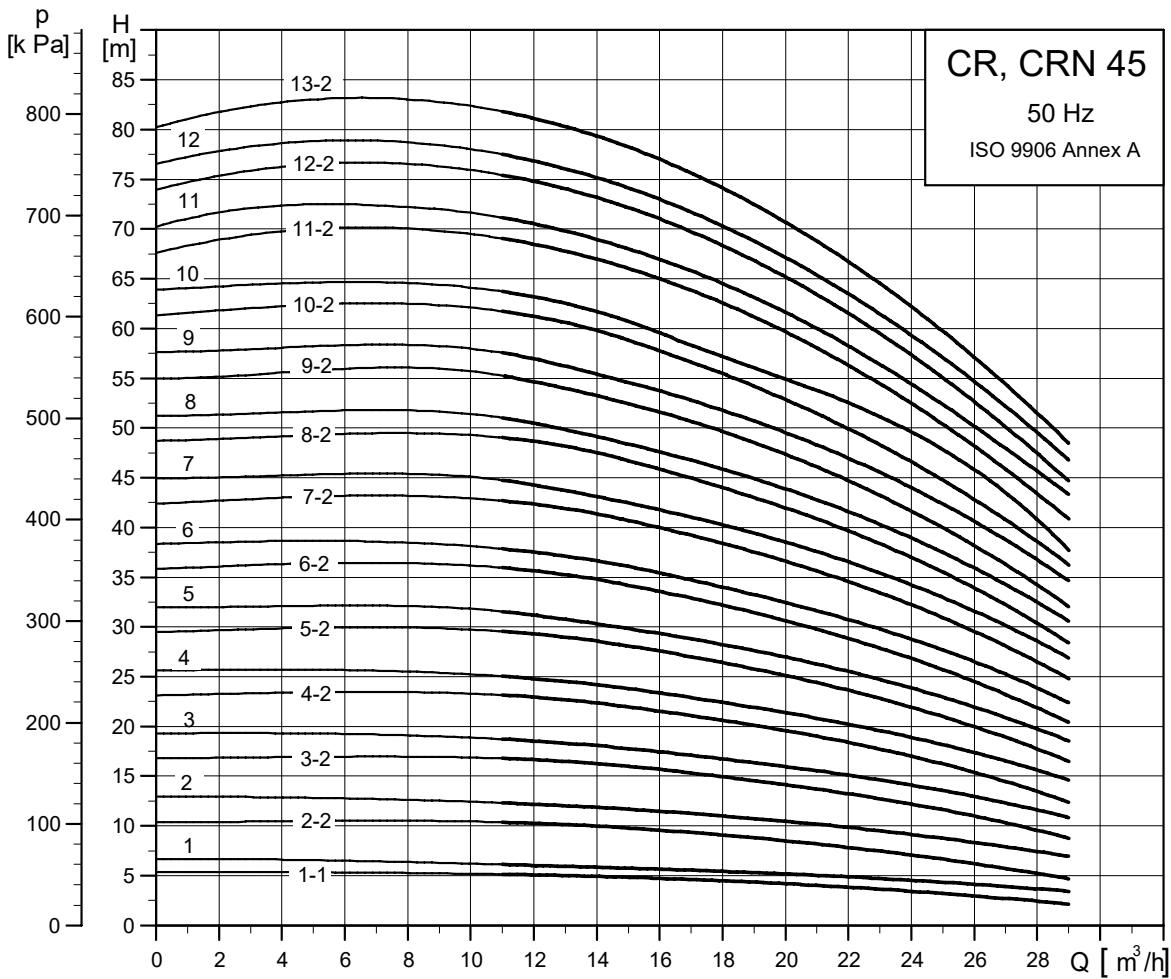

TM018154

CR pumps with 4-pole motor, 50 Hz: CR, CRN 64

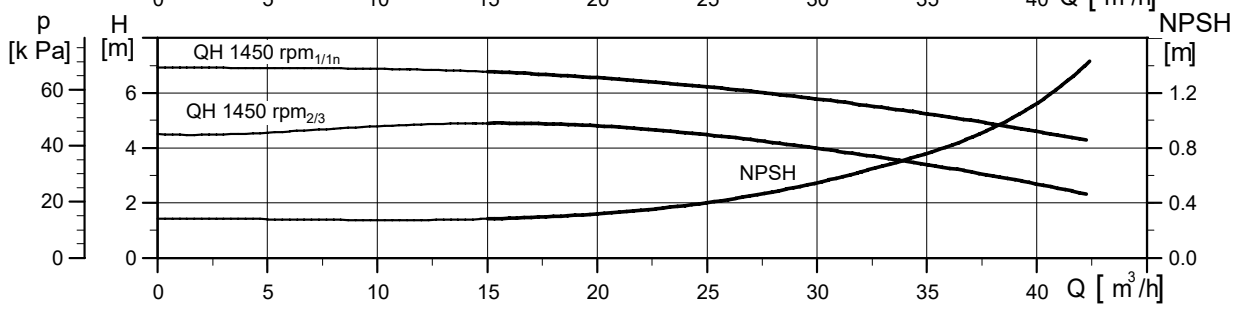
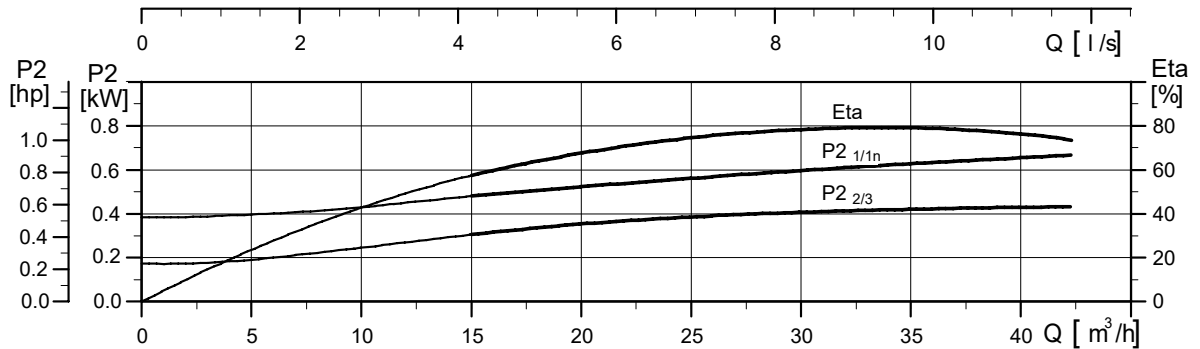
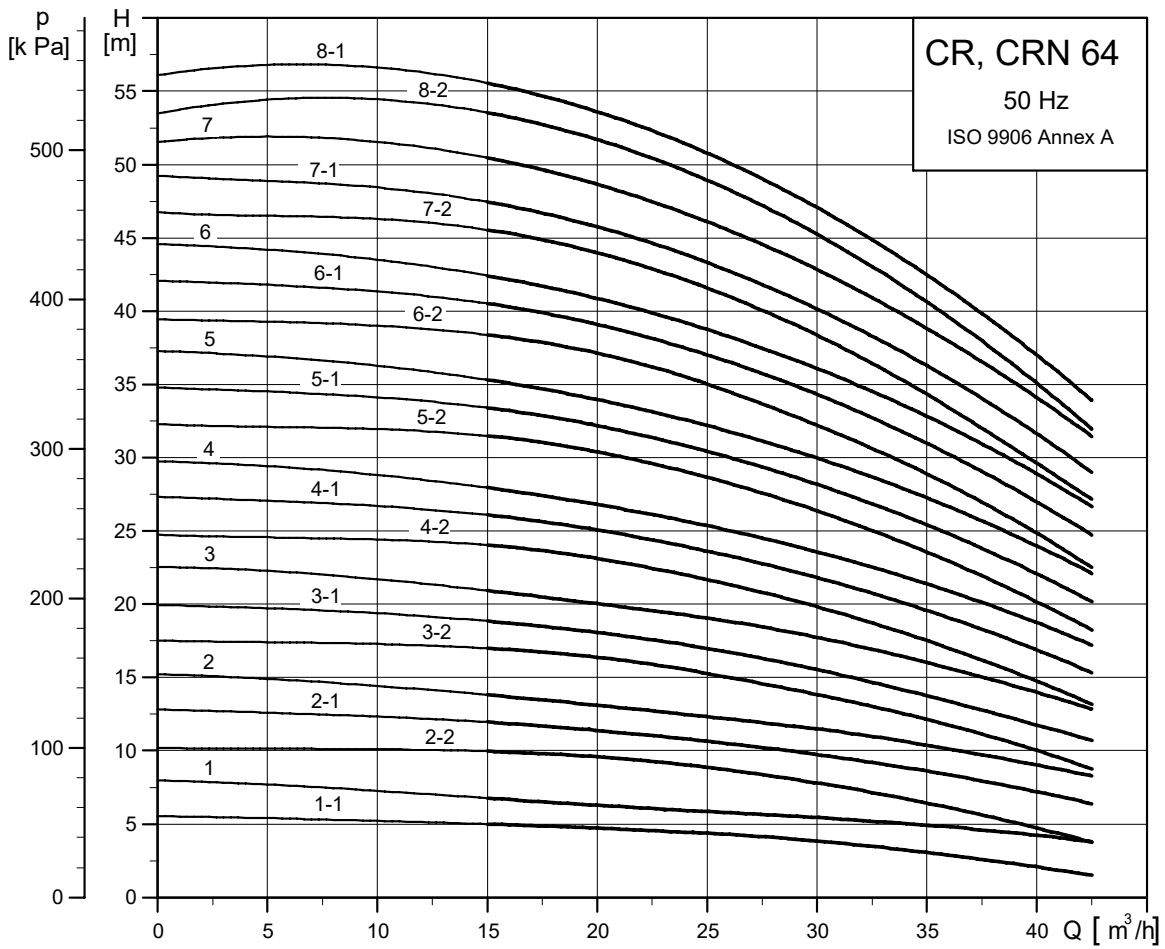

TM018155

CR pumps with 4-pole motor, 50 Hz: CR, CRN 95

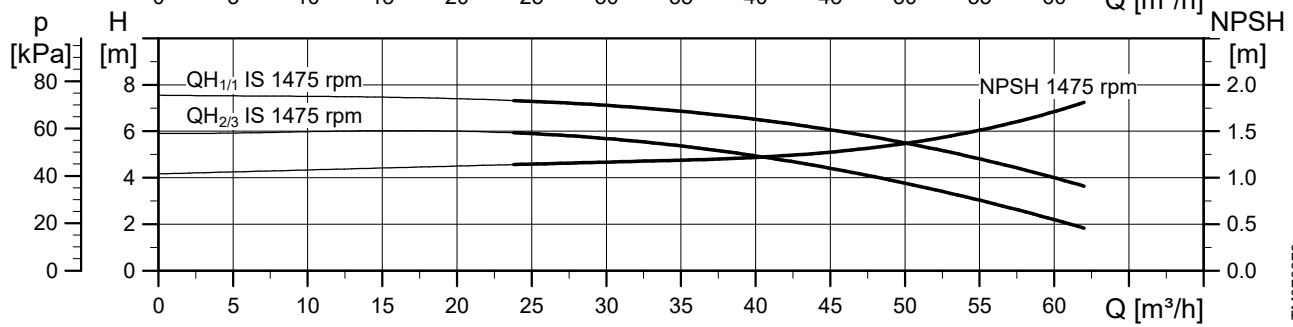
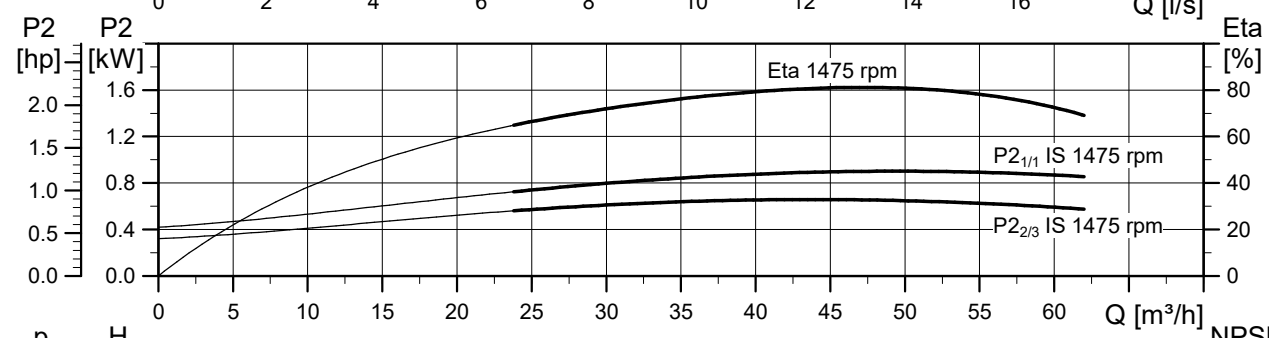
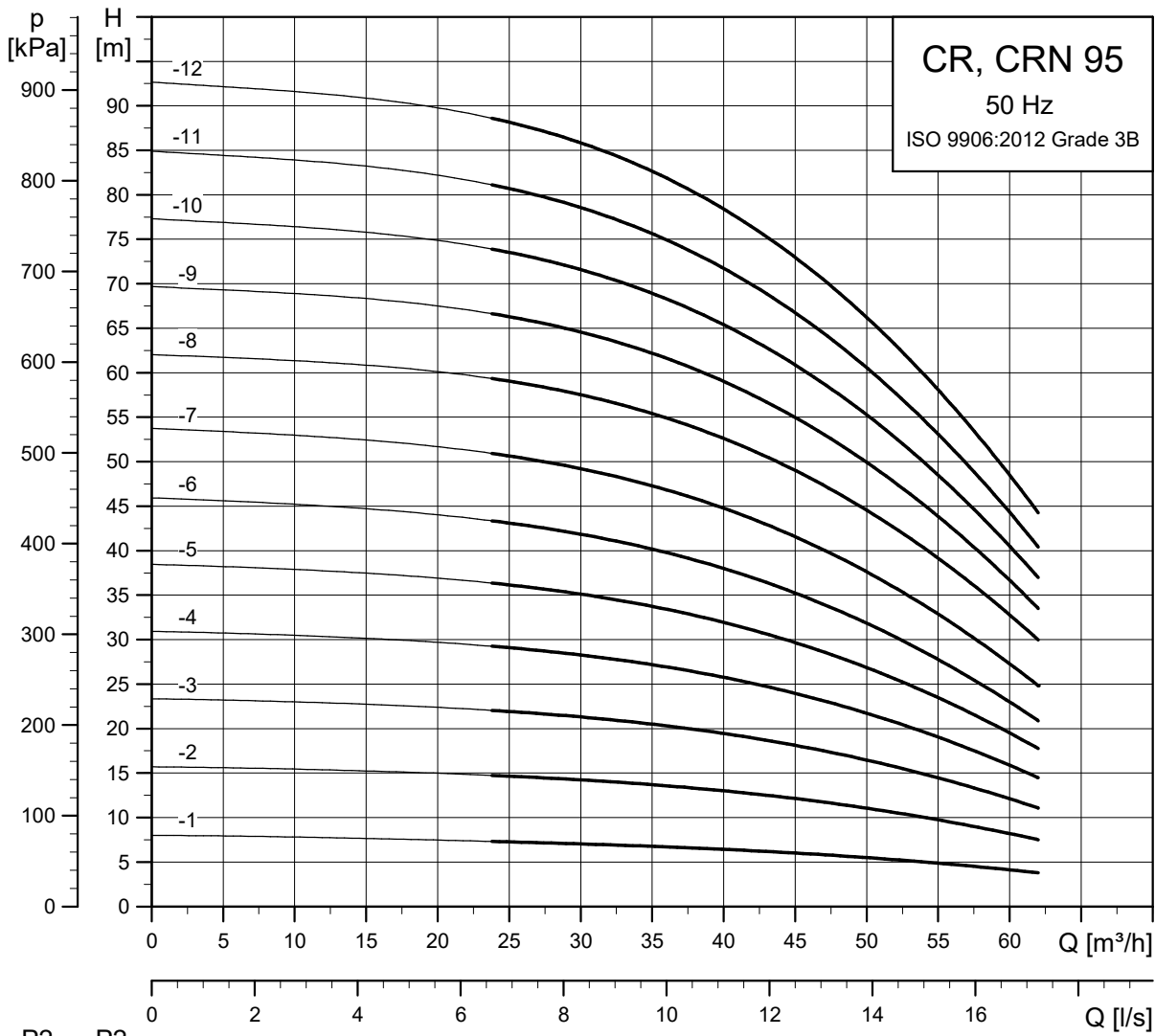

TM076979

CR pumps with 4-pole motor, 50 Hz: CR, CRN 125

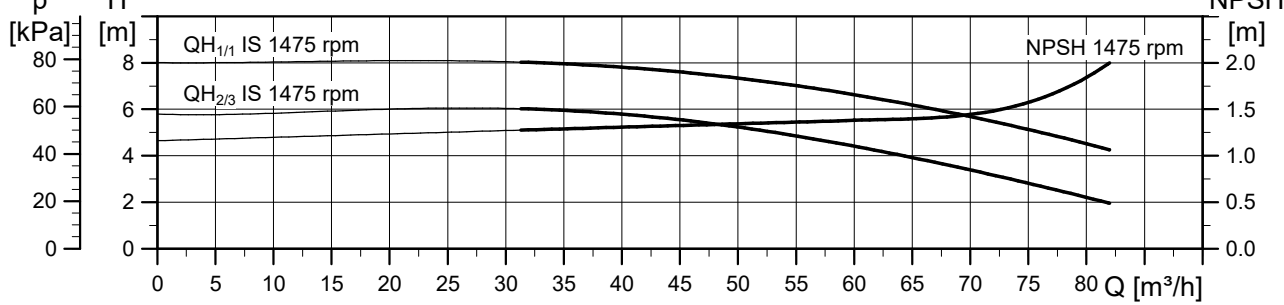
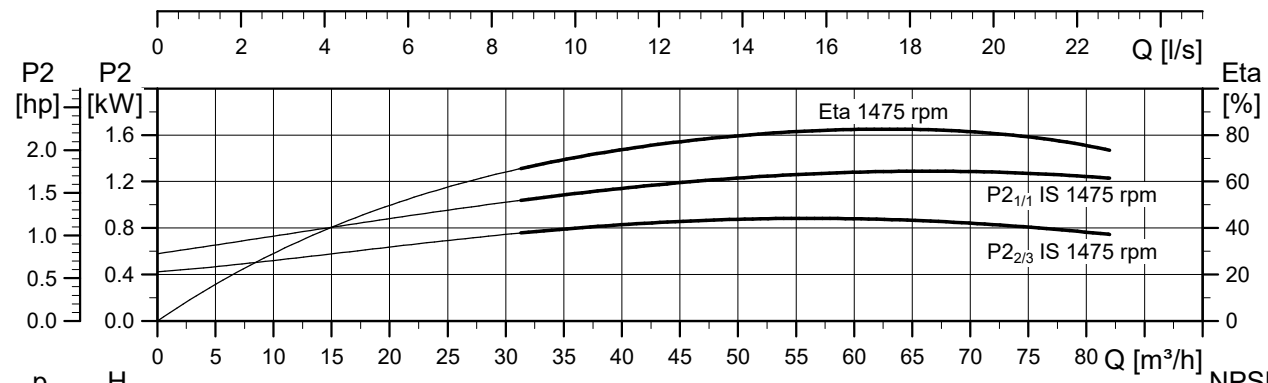
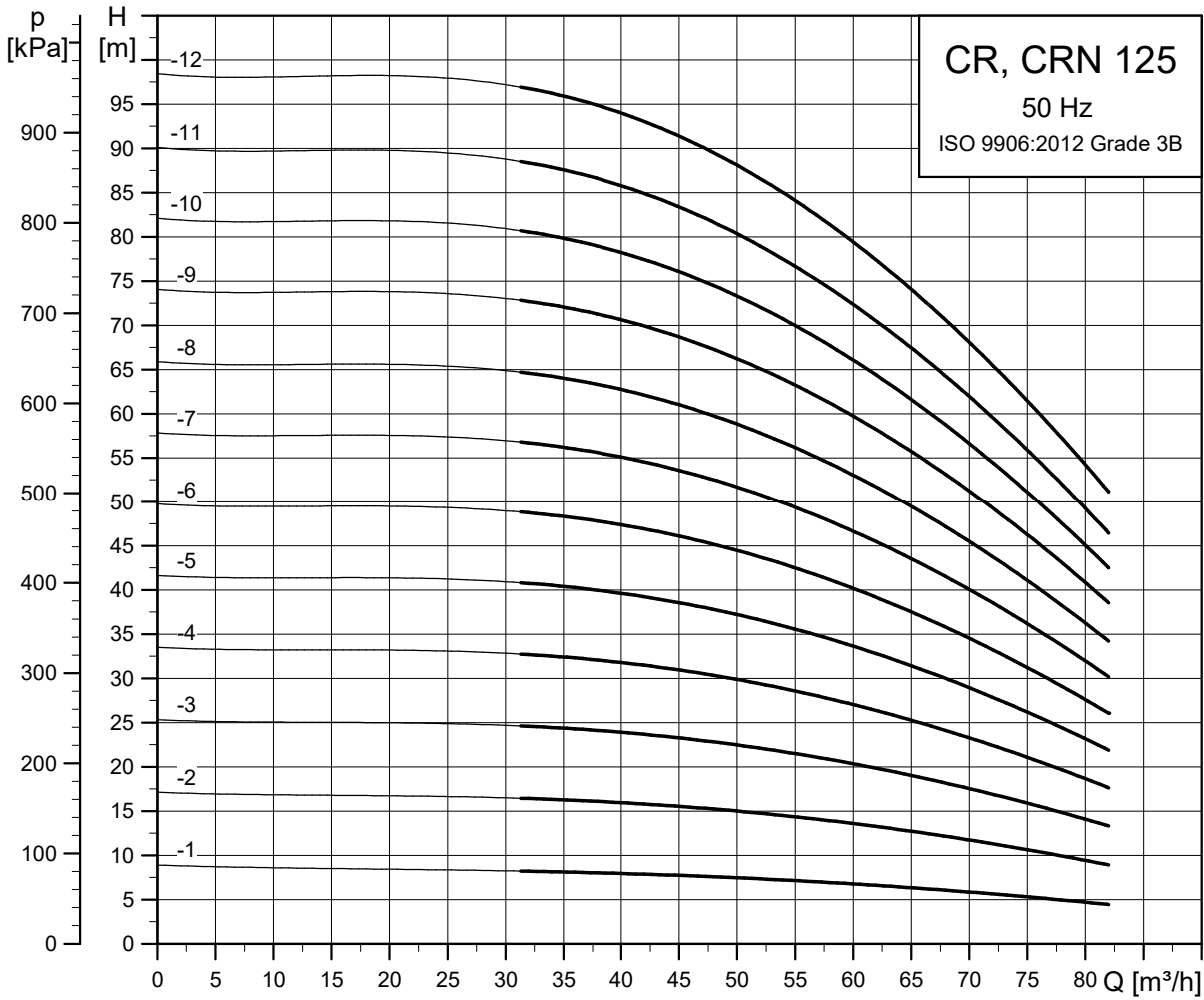

TM076980

CR pumps with 4-pole motor, 50 Hz: CR, CRN 155

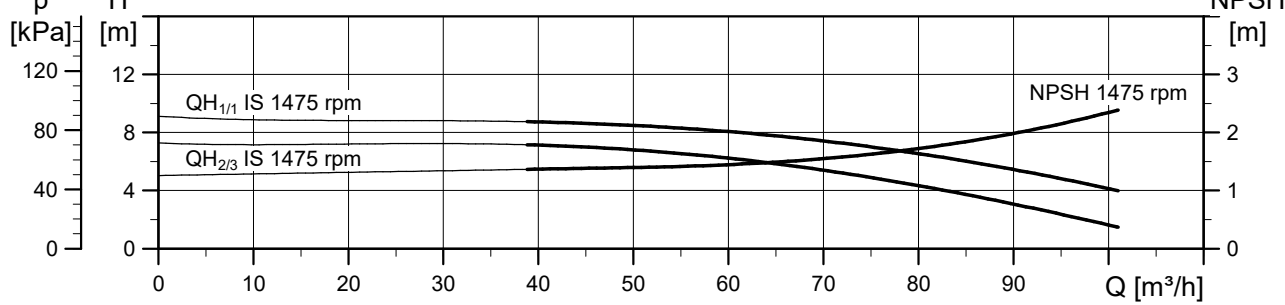
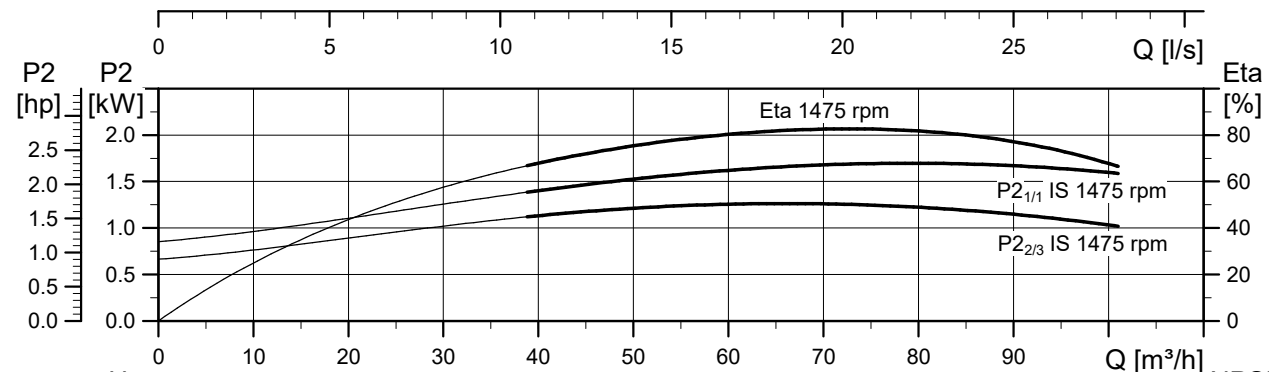
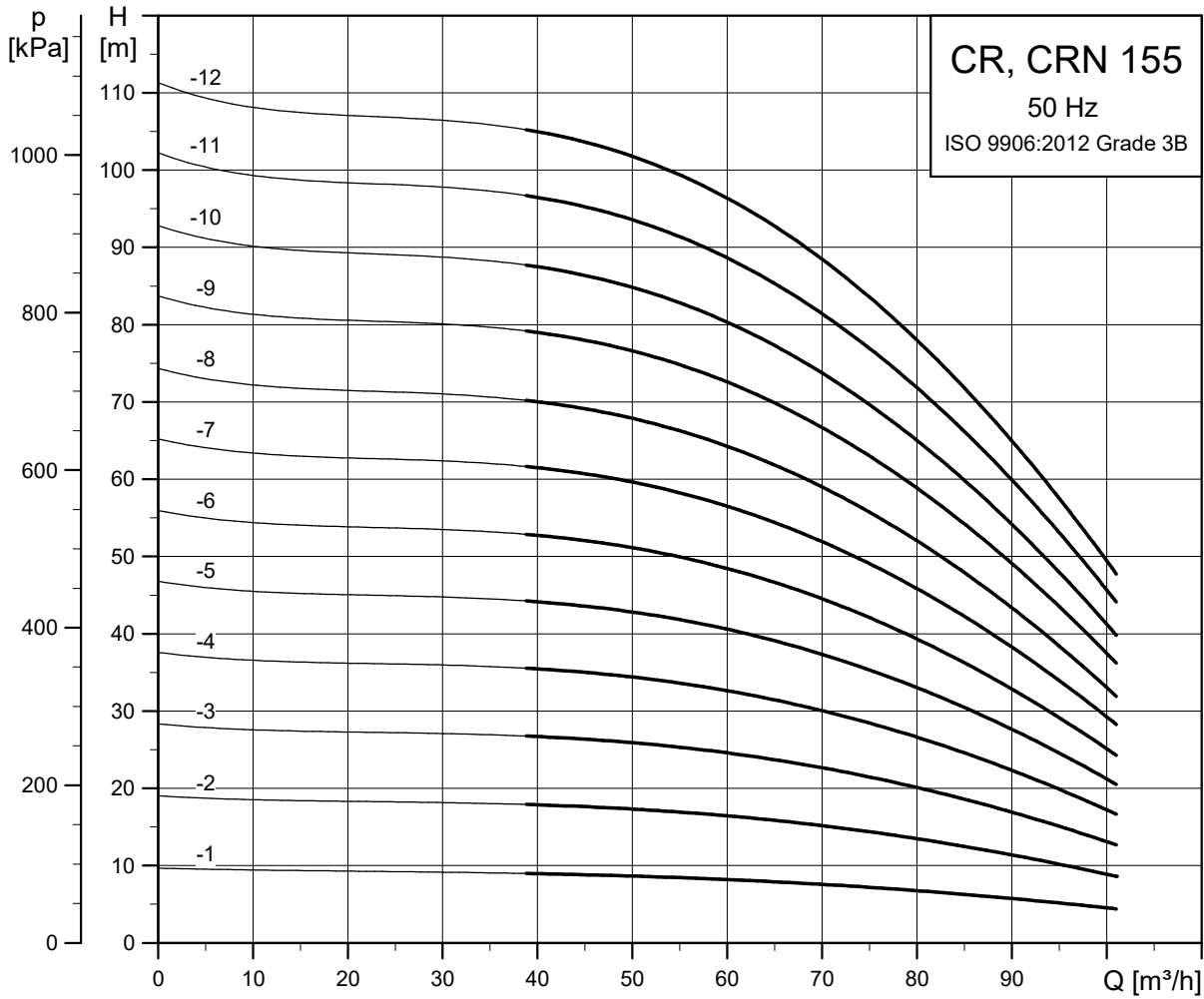

TM076981

CR pumps with 4-pole motor, 50 Hz: CR, CRN 185

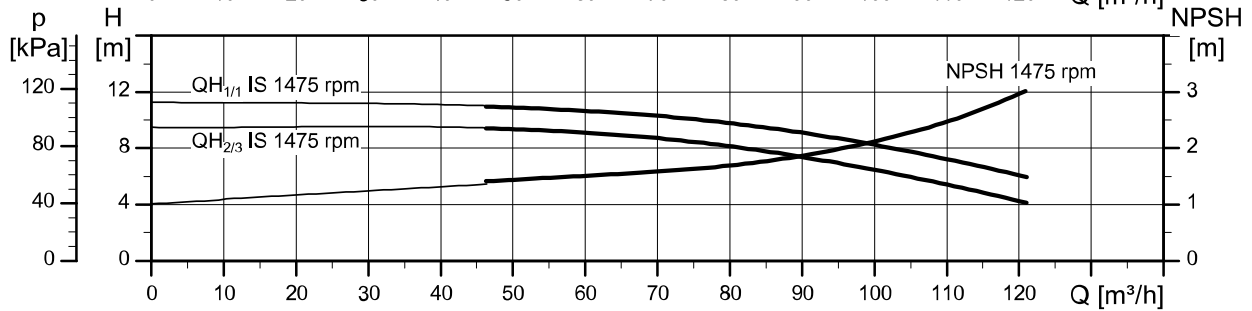
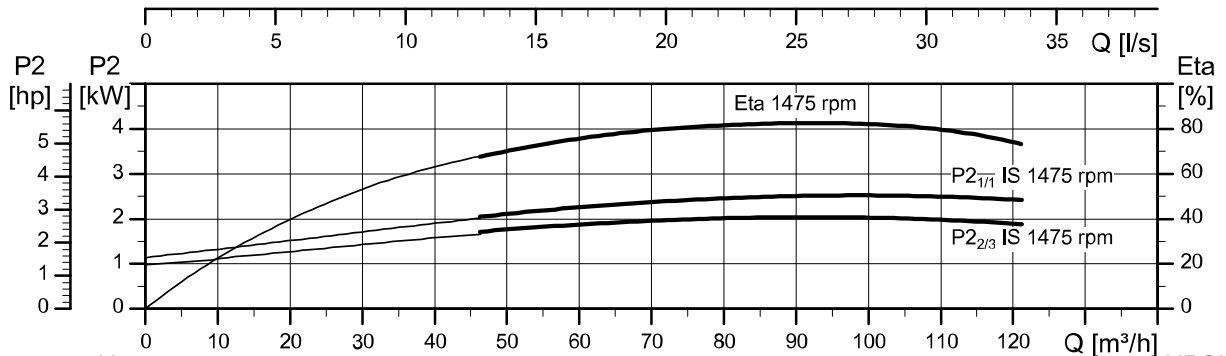
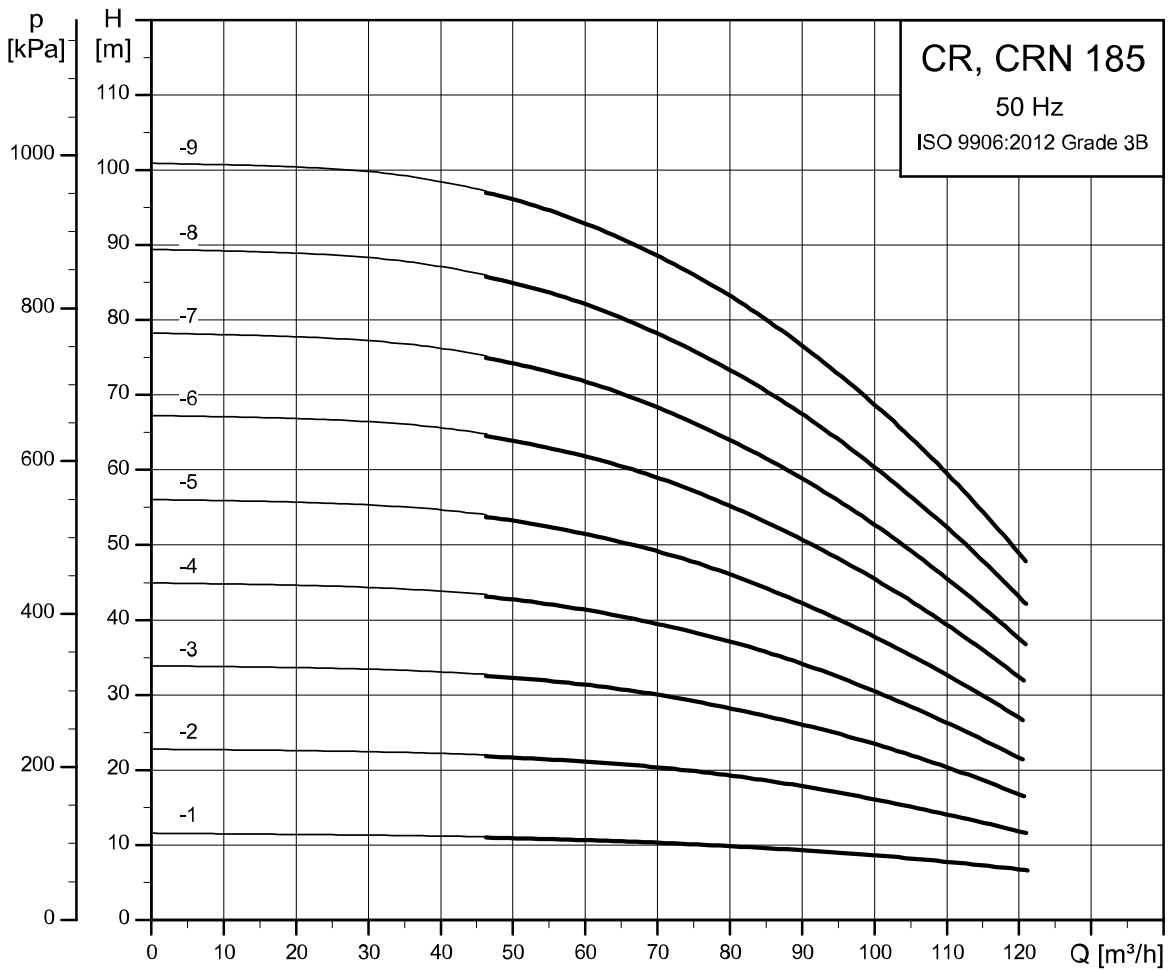

TM076982

CR pumps with 4-pole motor, 50 Hz: CR, CRN 215

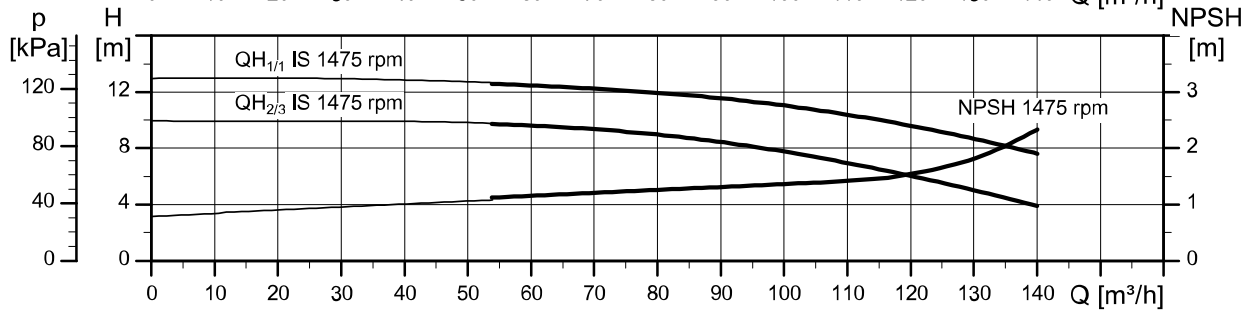
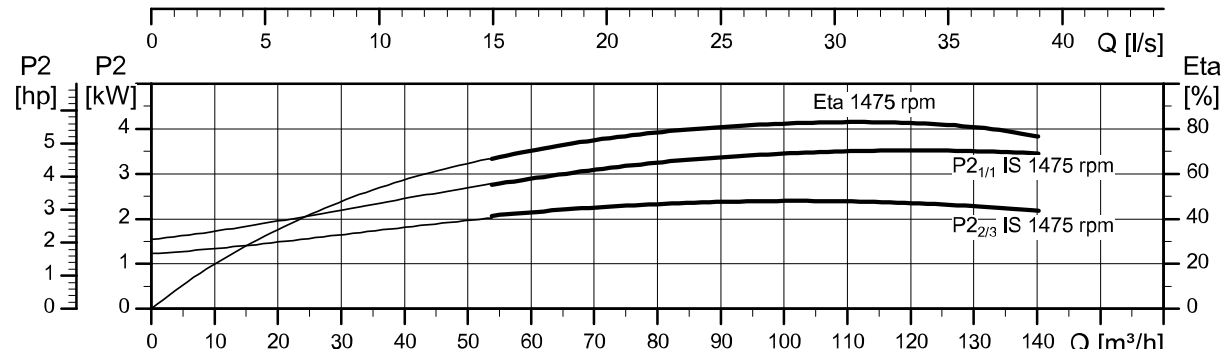
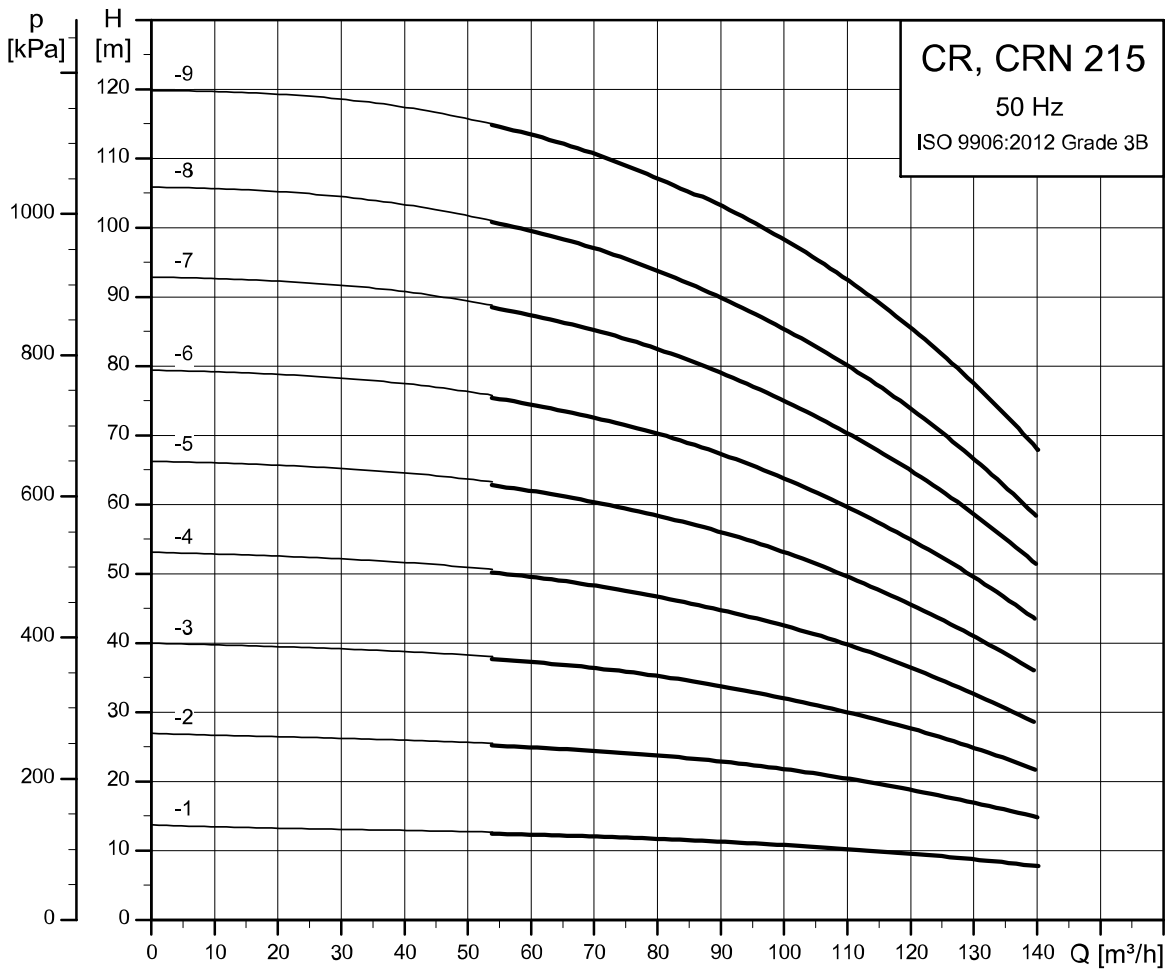

TM078942

CR pumps with 4-pole motor, 50 Hz: CR, CRN 255

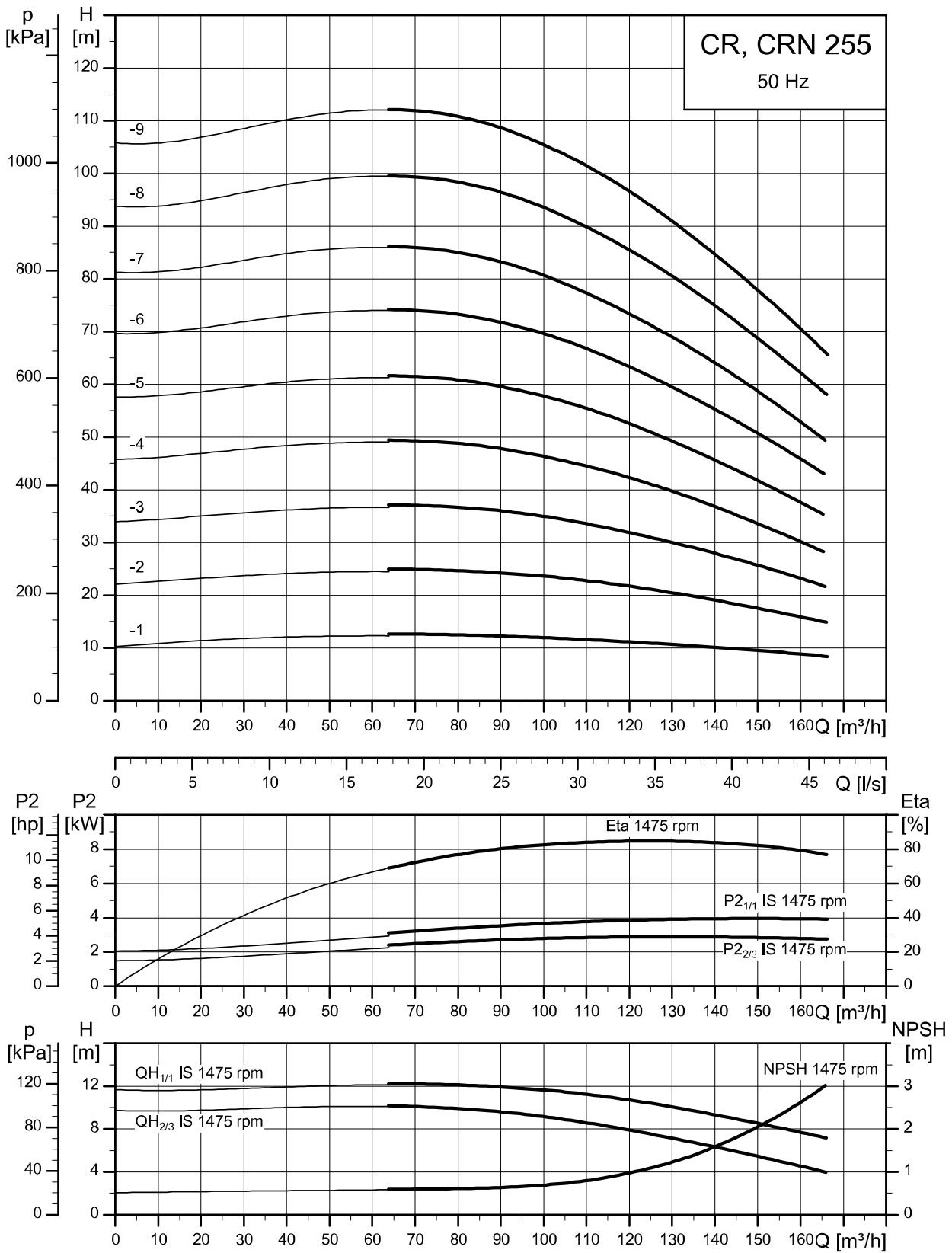

TM090278

Preliminary calculated performance curves.

CR pumps with 4-pole motor, 60 Hz

CR pumps with 4-pole motor, 60 Hz: CR, CRI, CRN 1

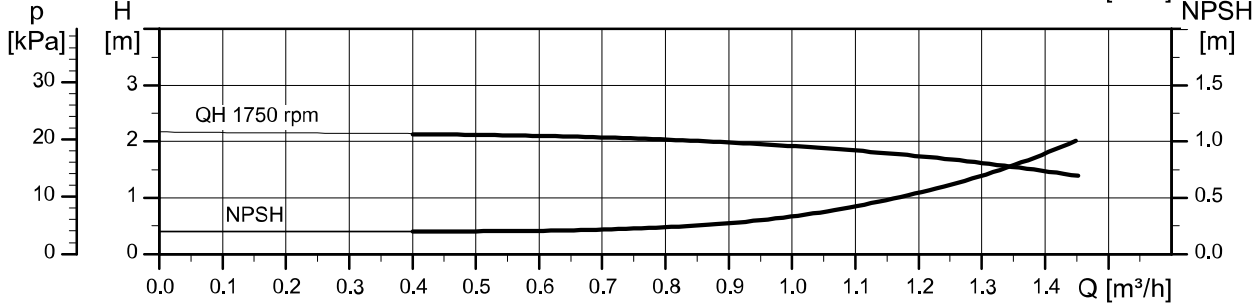
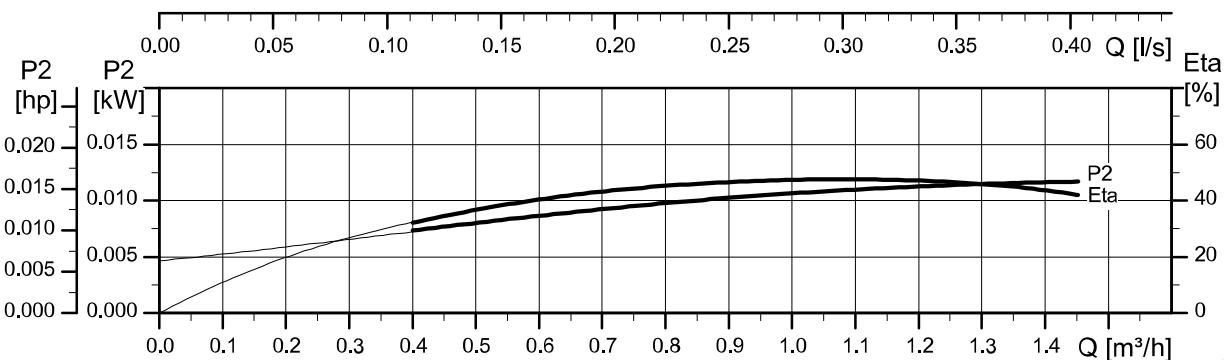
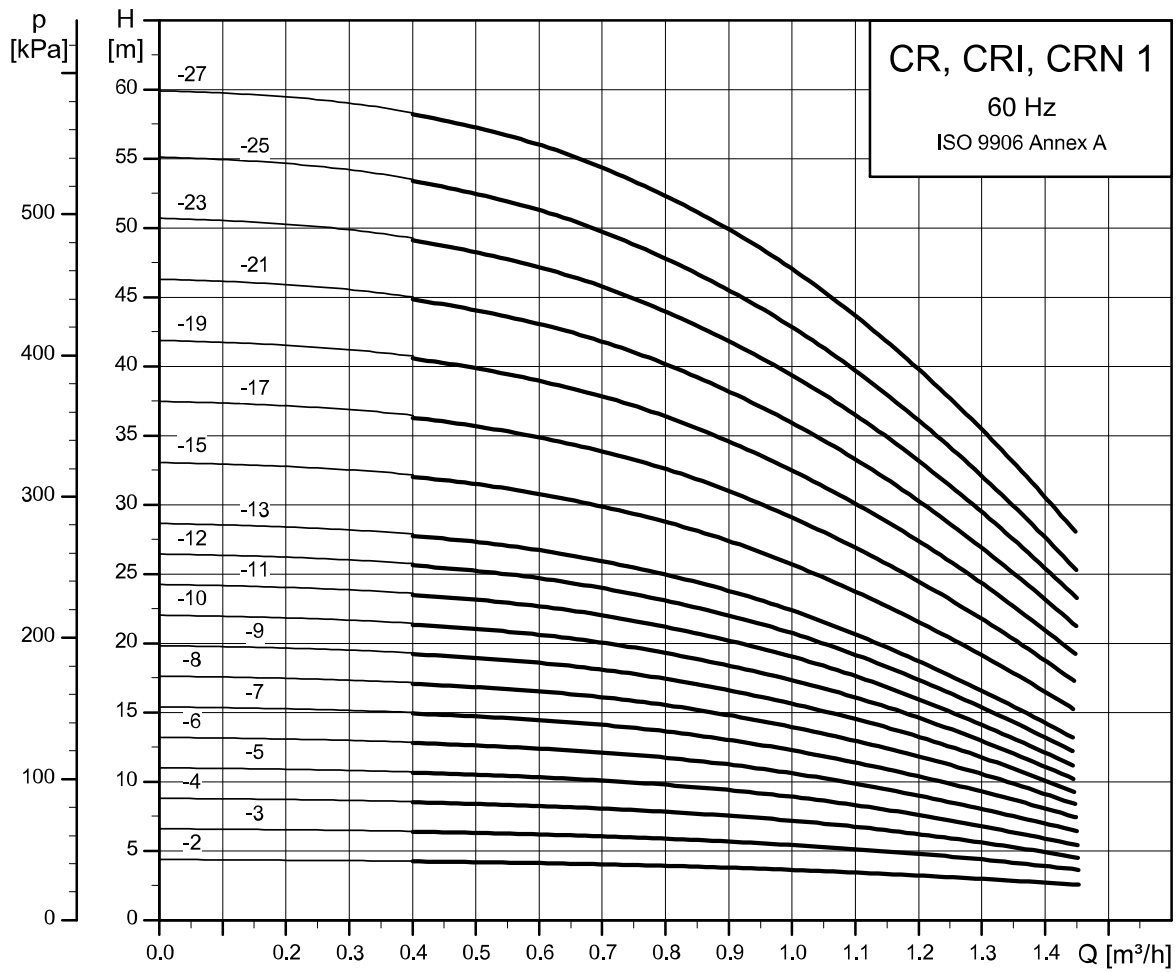

TM022540

CR pumps with 4-pole motor, 60 Hz: CR, CRI, CRN 3

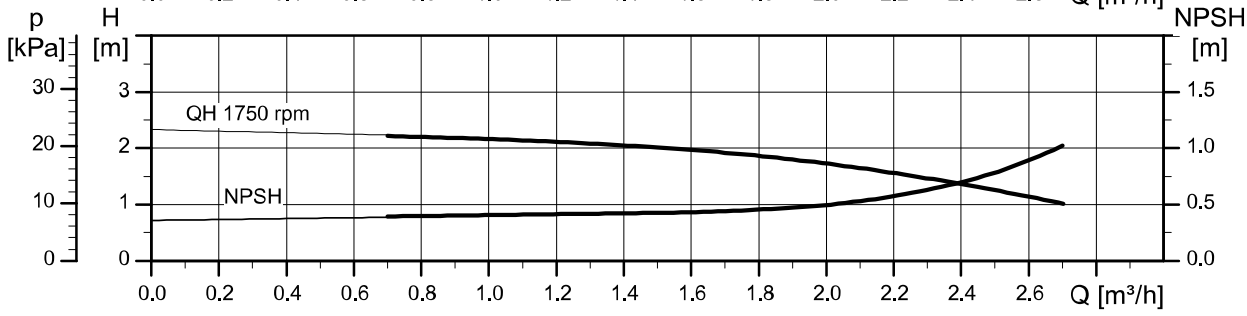
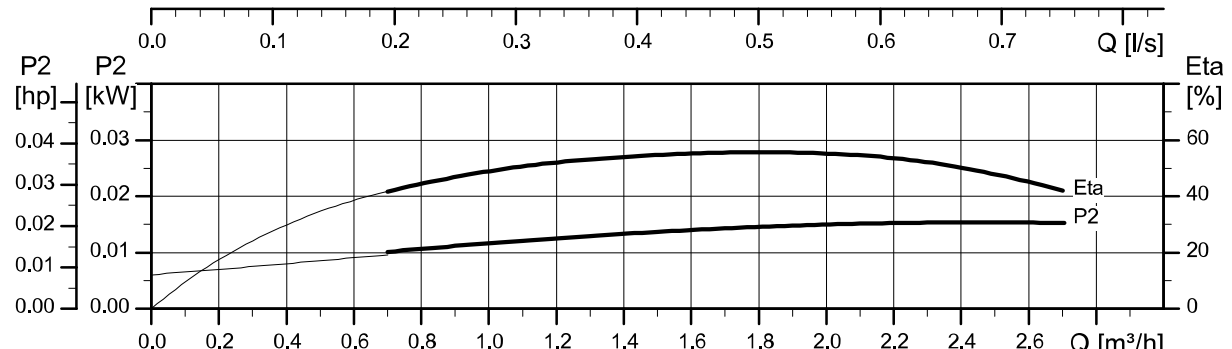
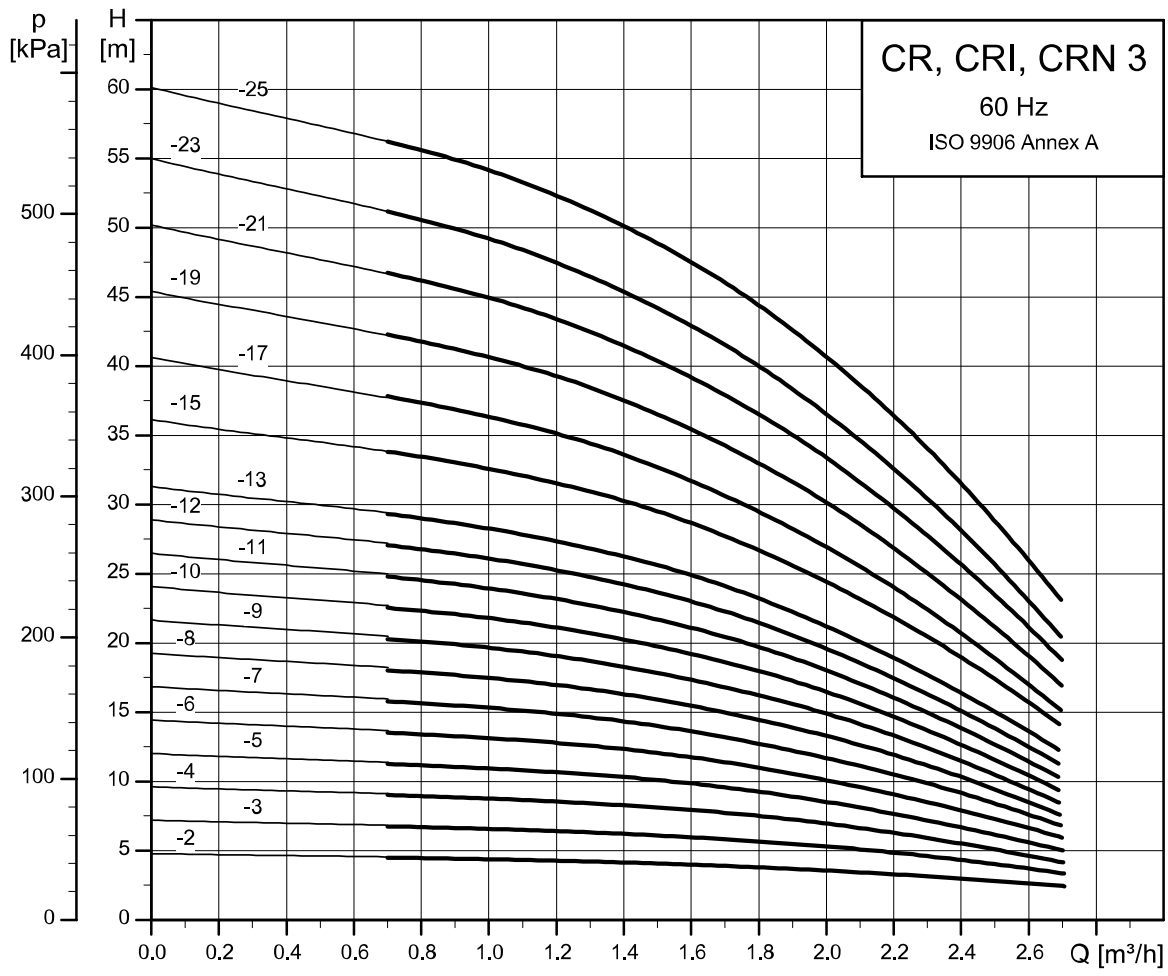

TM022539

CR pumps with 4-pole motor, 60 Hz: CR, CRI, CRN 5

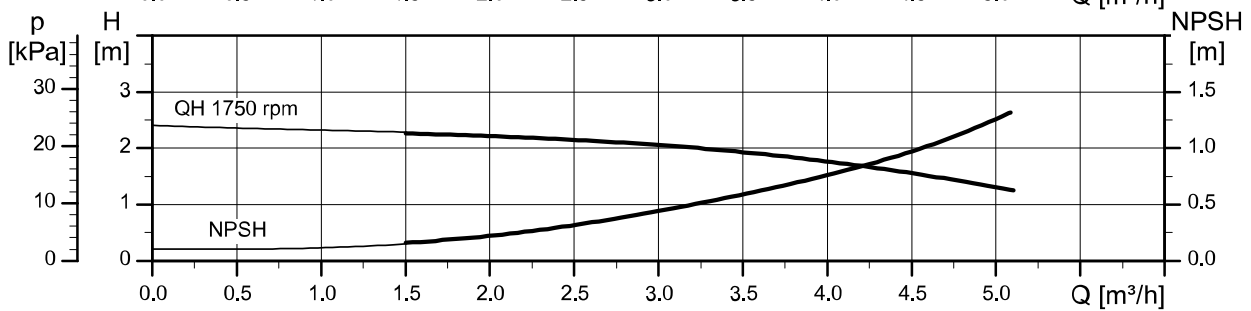
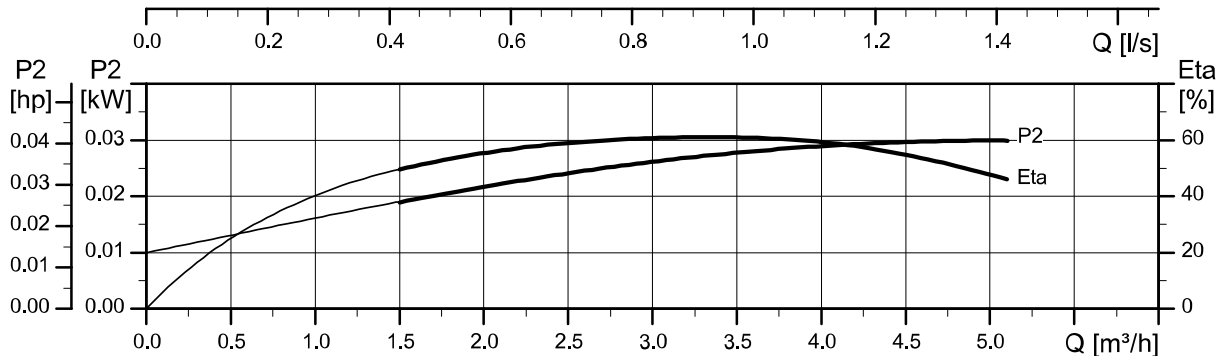
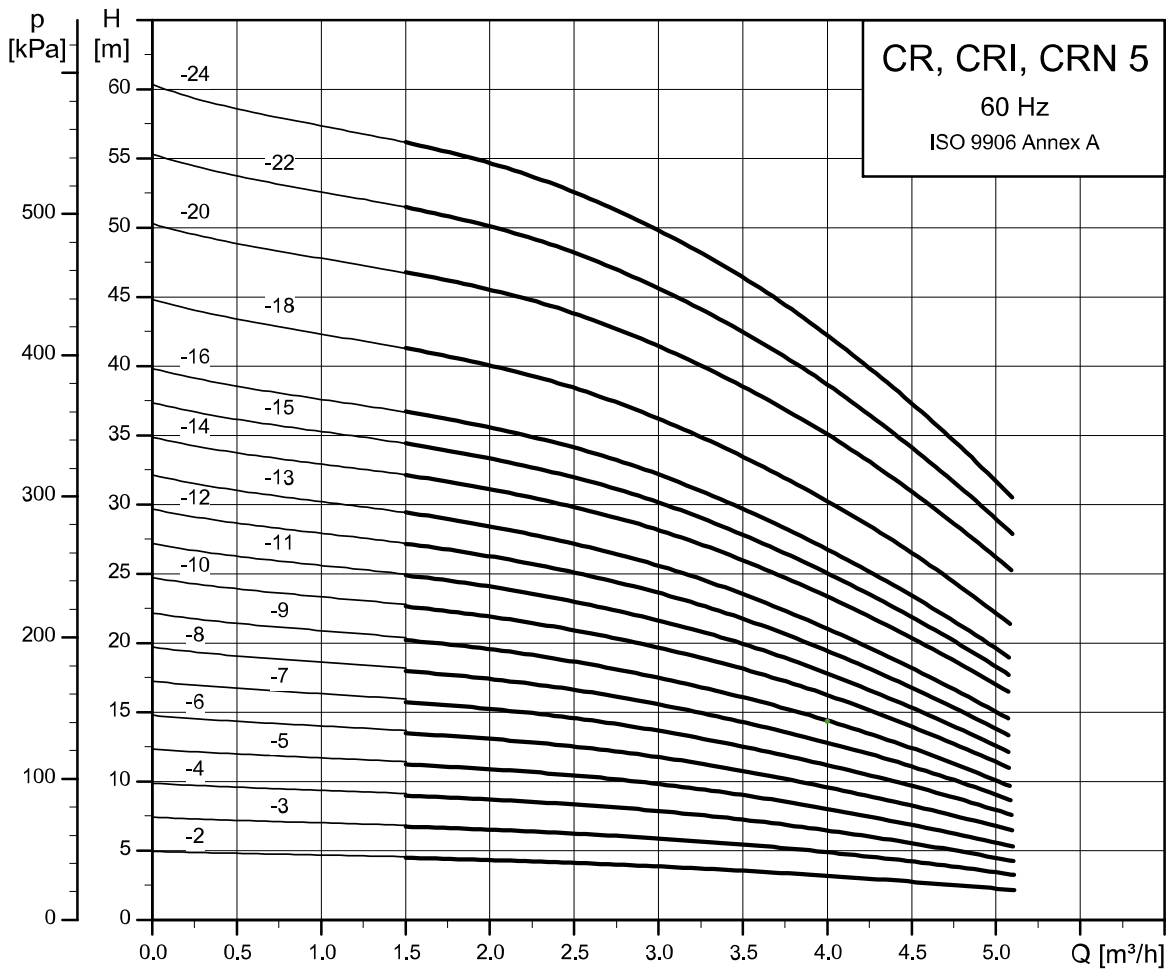

TM022538

CR pumps with 4-pole motor, 60 Hz: CR, CRI, CRN 10

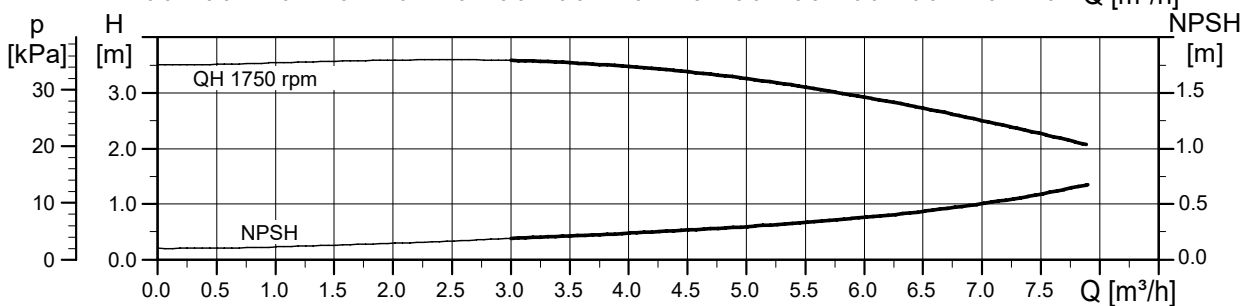
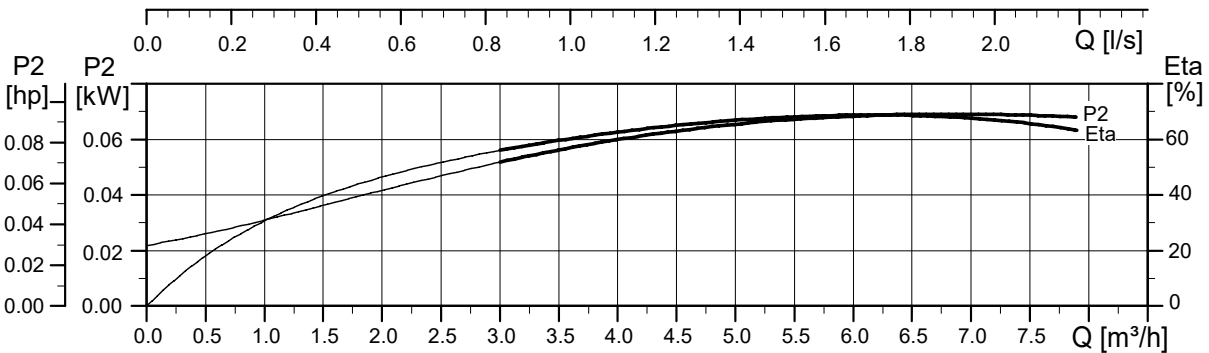
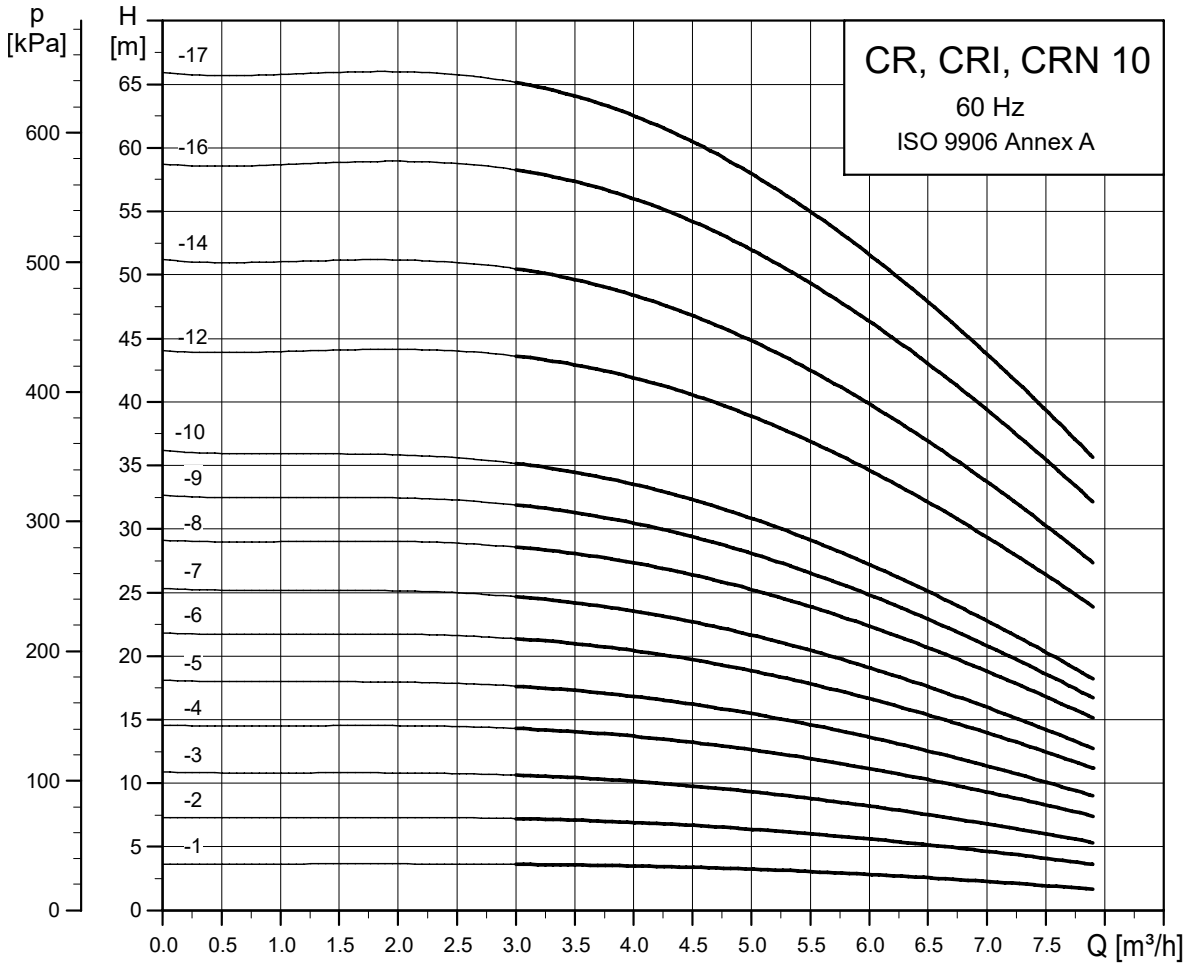

TM027276

CR pumps with 4-pole motor, 60 Hz: CR, CRI, CRN 15

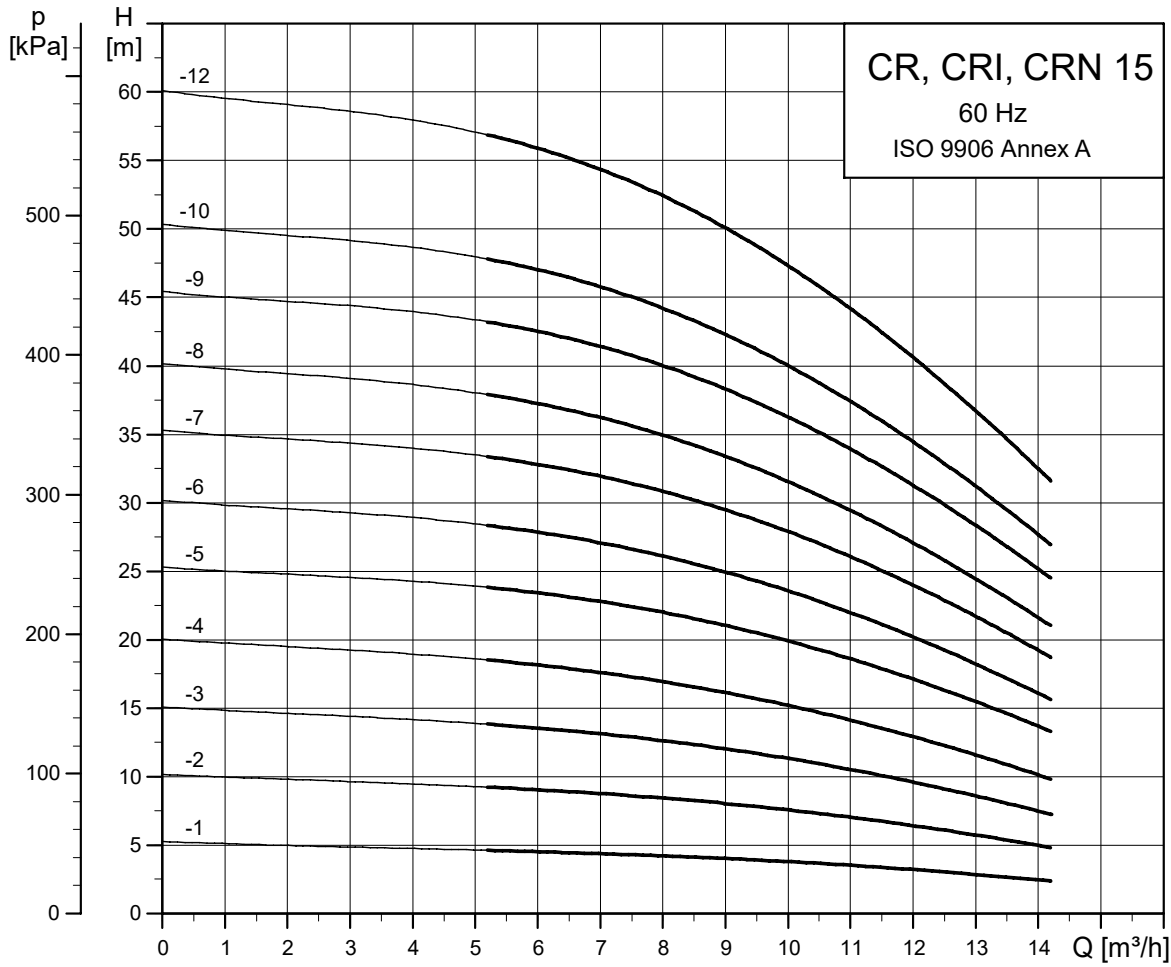

0.0 0.5 1.0 1.5 2.0 2.5 3.0 3.5 4.0 Q [l/s]

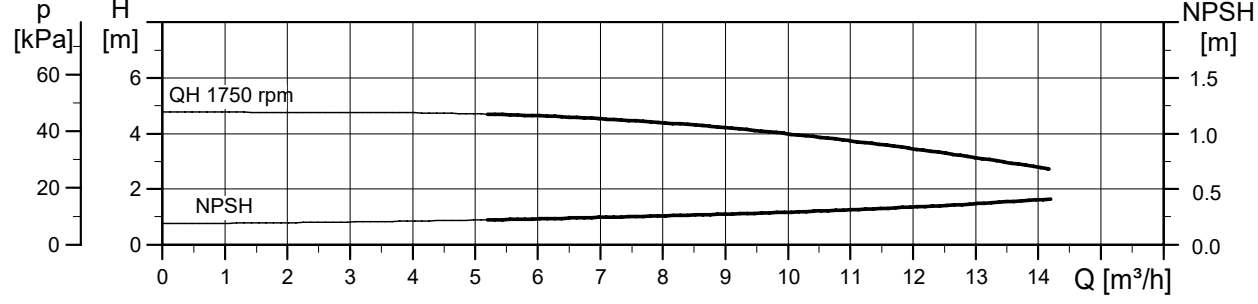
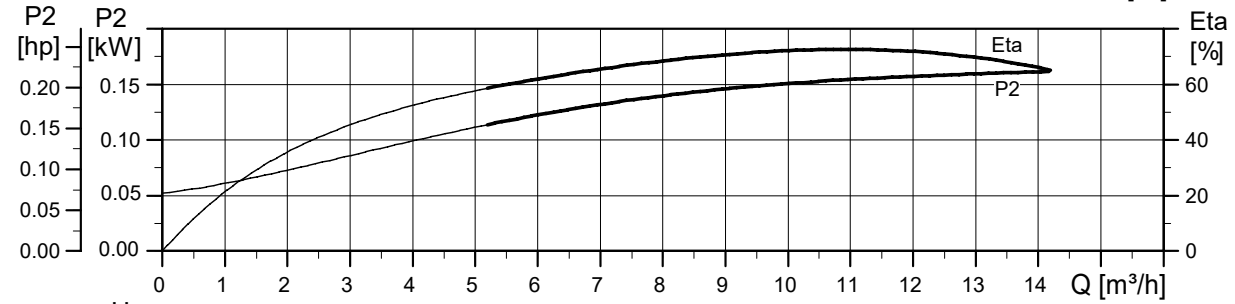

TM027277

CR pumps with 4-pole motor, 60 Hz: CR, CRI, CRN 20

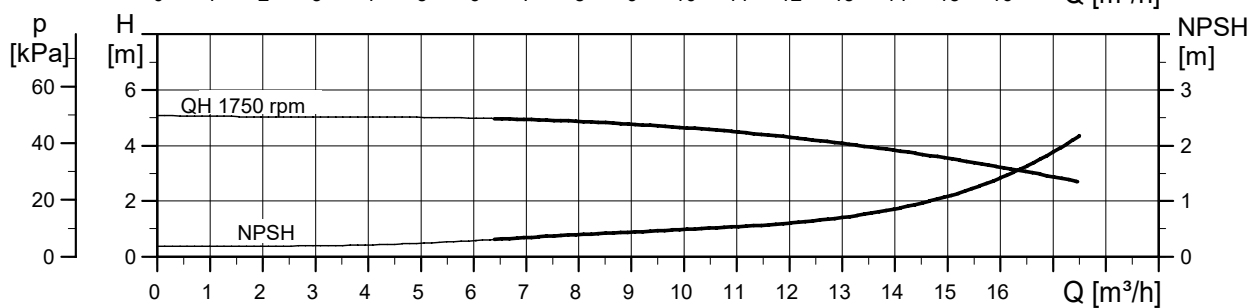
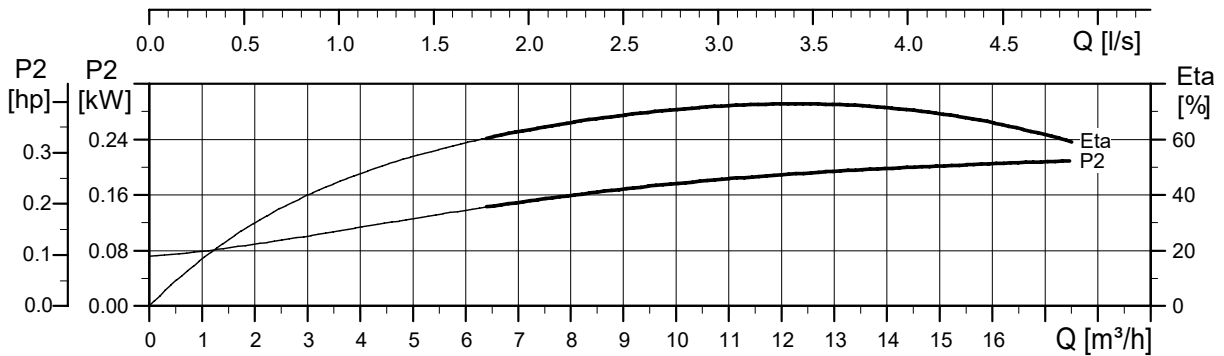
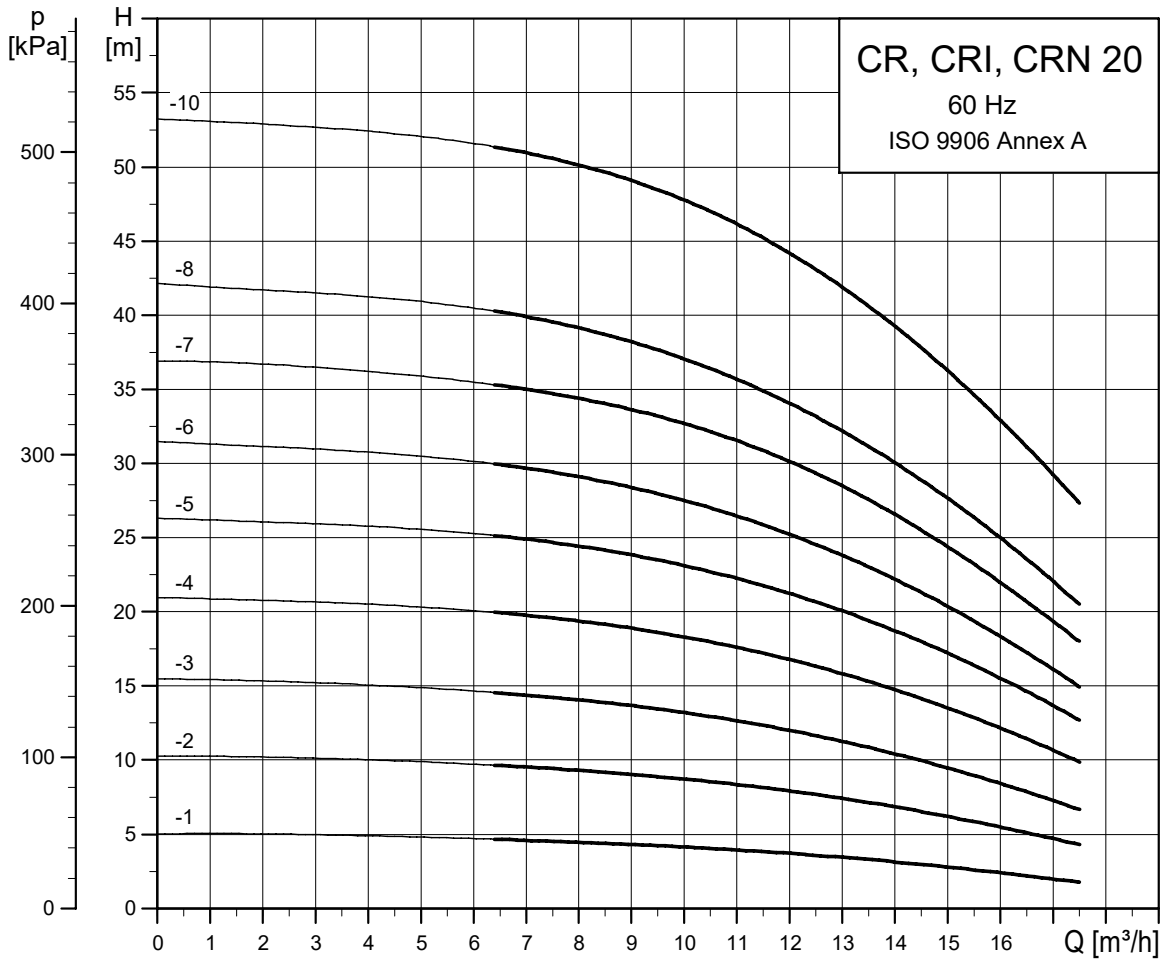

TM027278

CR pumps with 4-pole motor, 60 Hz: CR, CRN 32

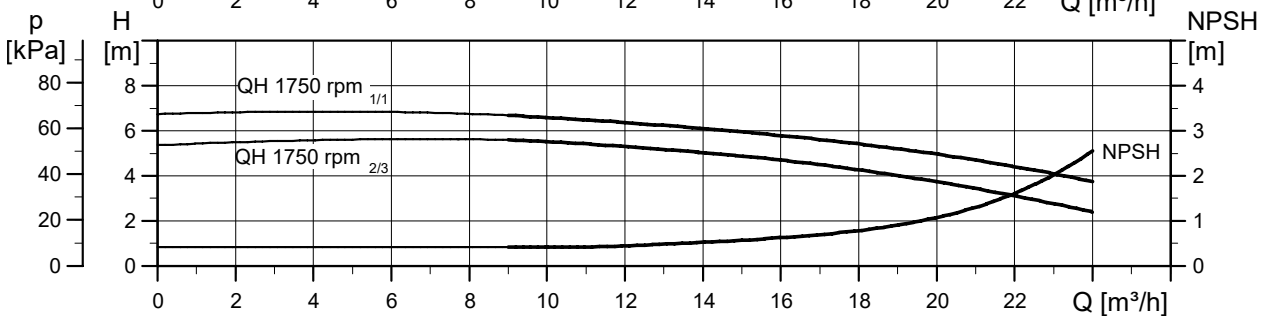
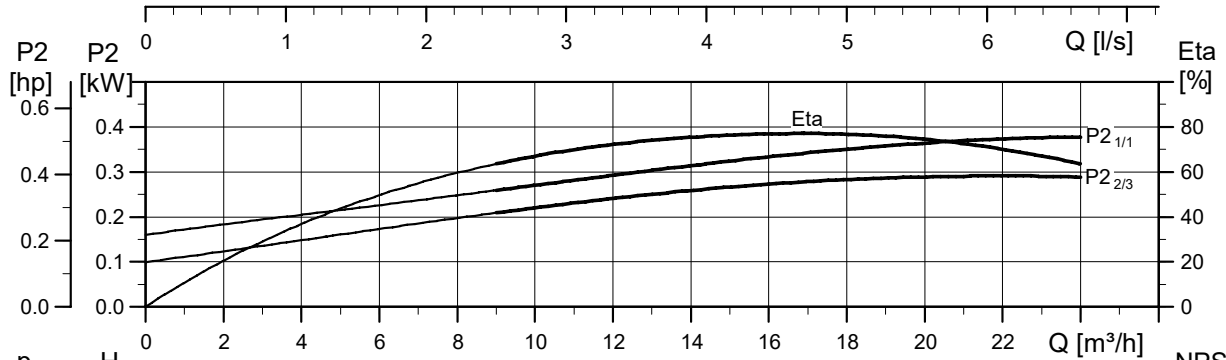
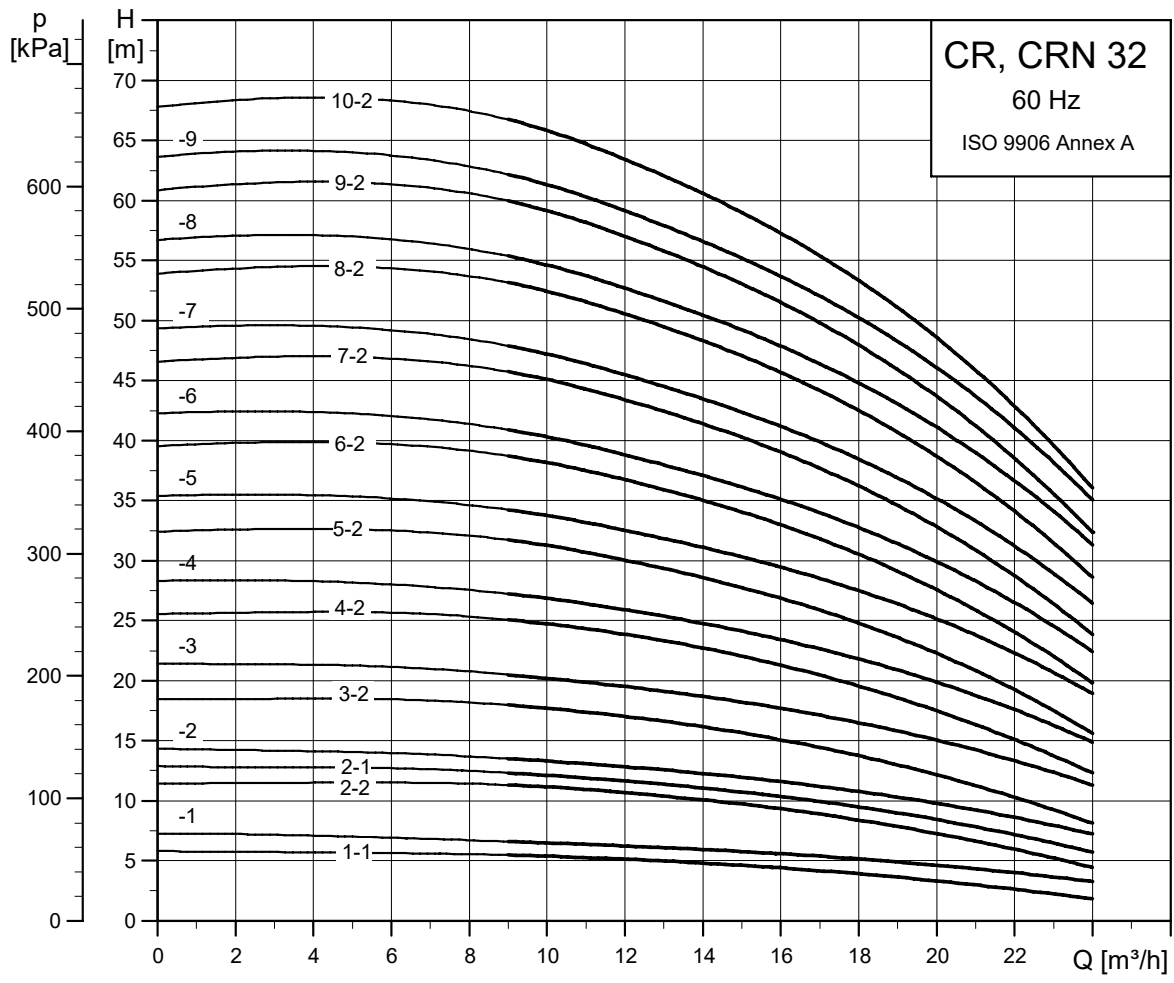

TM018157

CR pumps with 4-pole motor, 60 Hz: CR, CRN 45

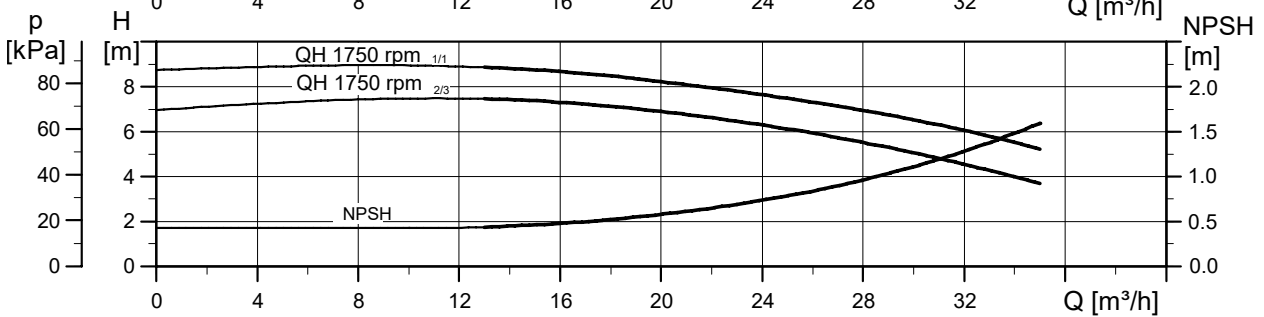
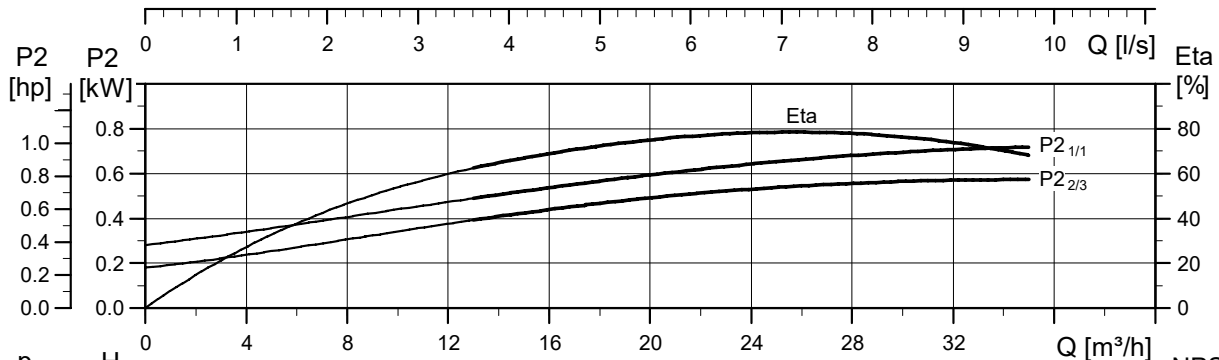
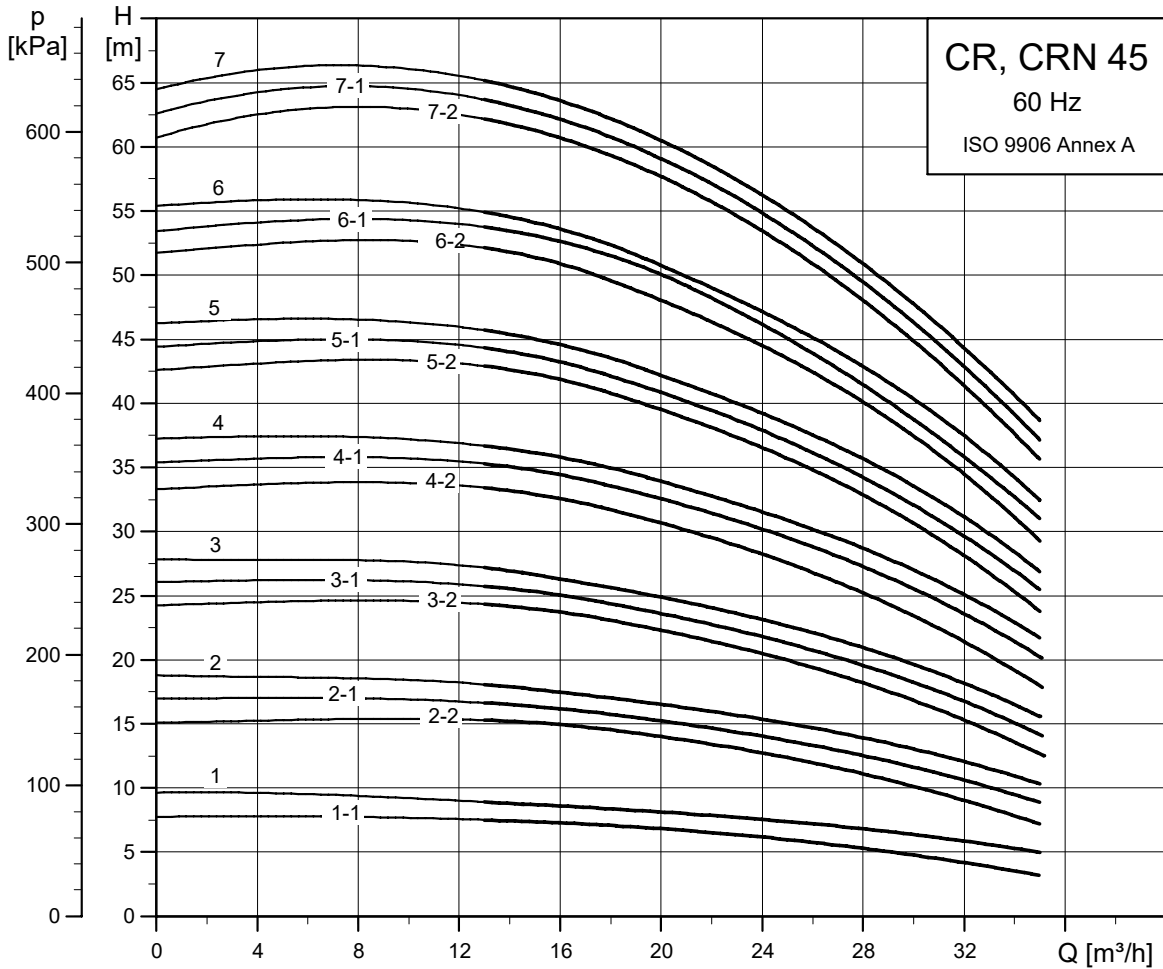

TM018158

CR pumps with 4-pole motor, 60 Hz: CR, CRN 64

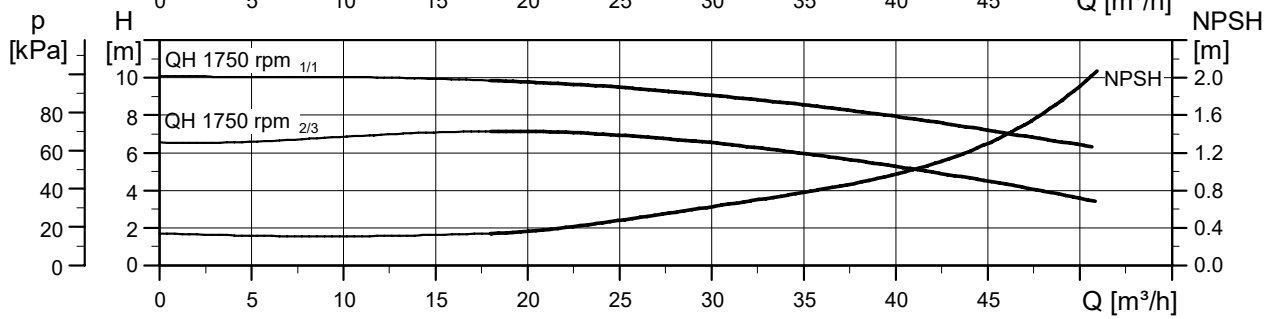
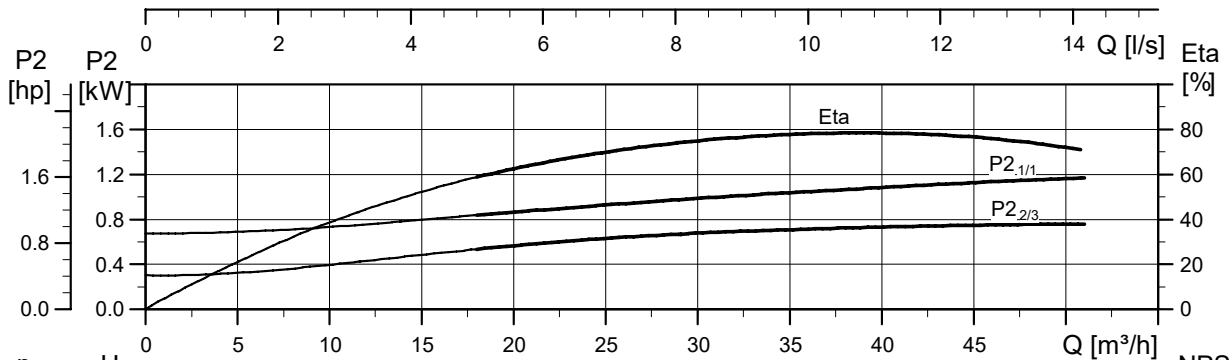
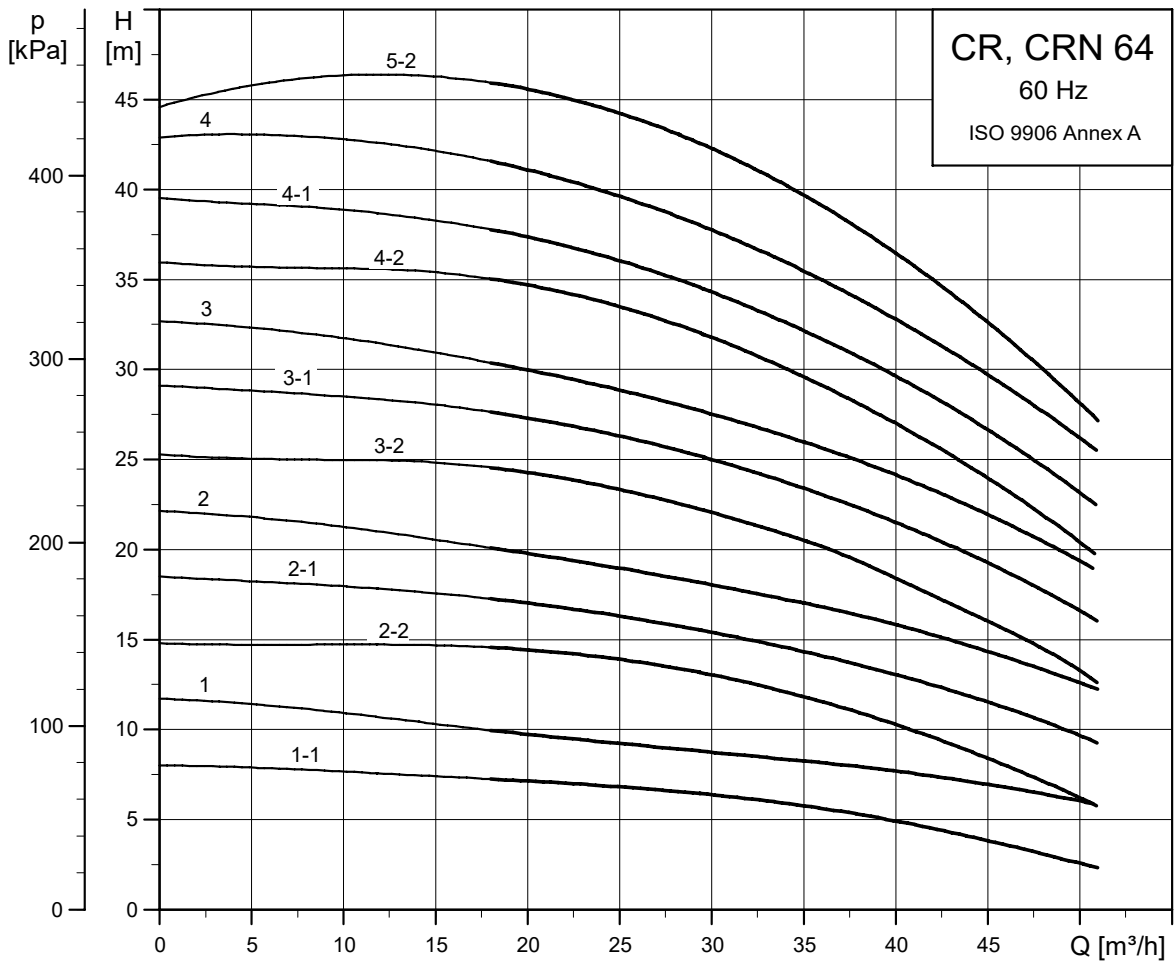

TMO18159

CR pumps with 4-pole motor, 60 Hz: CR, CRN 95

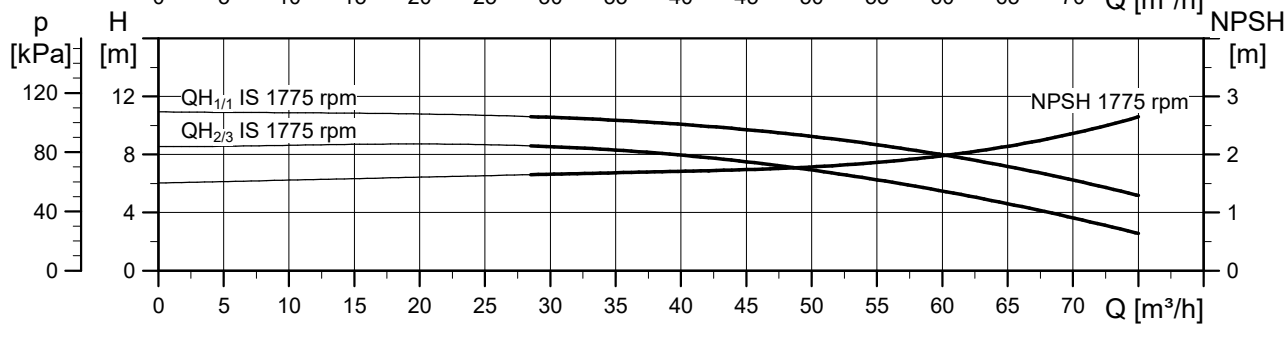
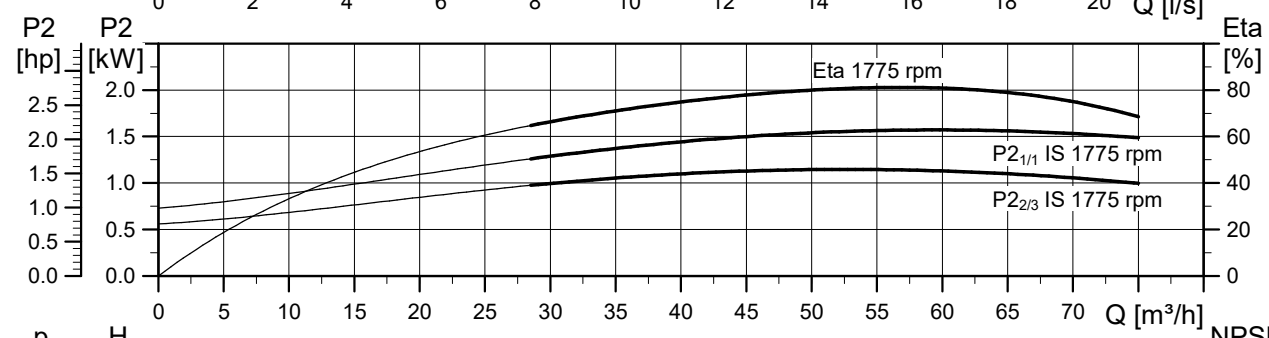
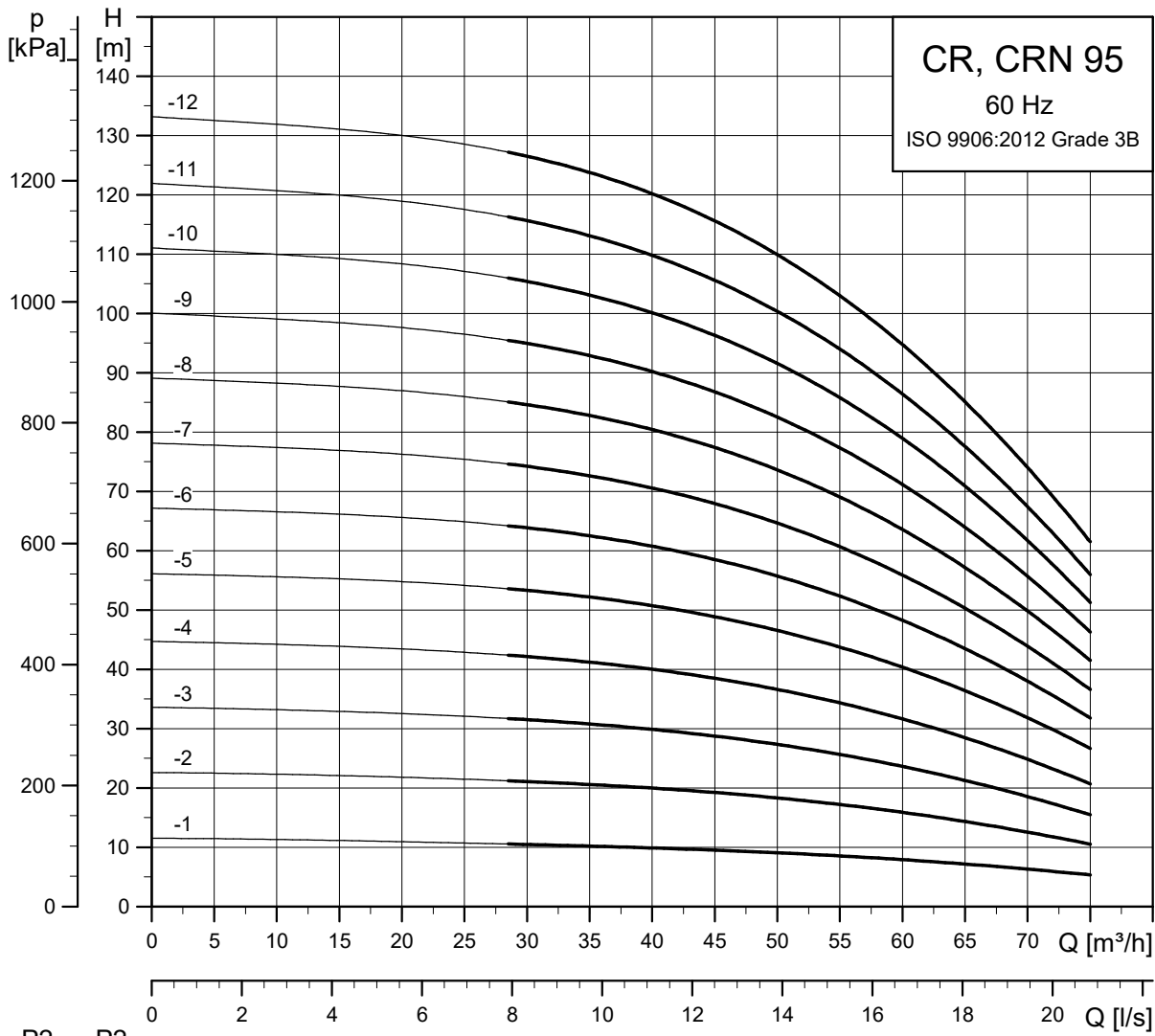

TM076983

CR pumps with 4-pole motor, 60 Hz: CR, CRN 125

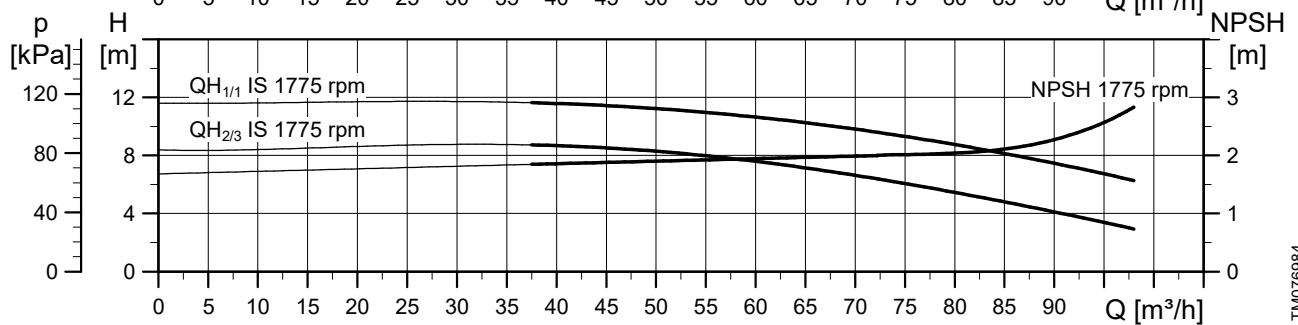
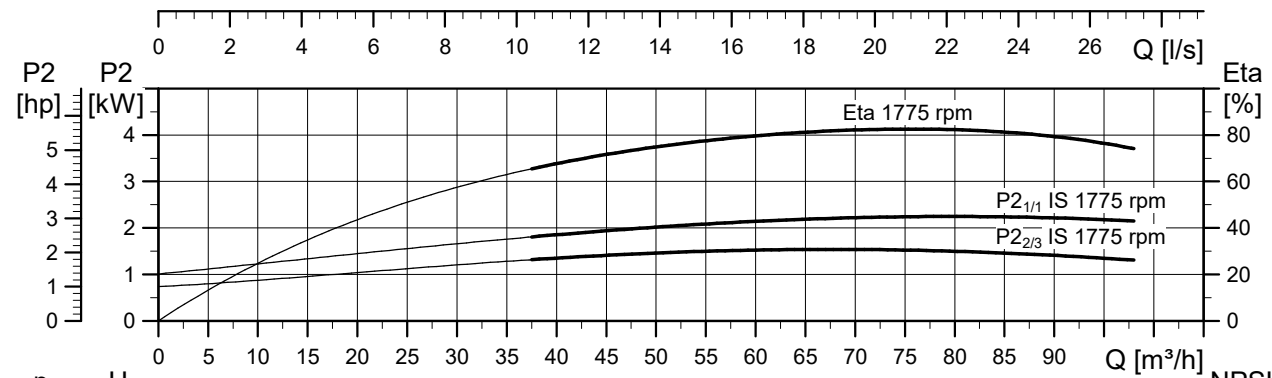
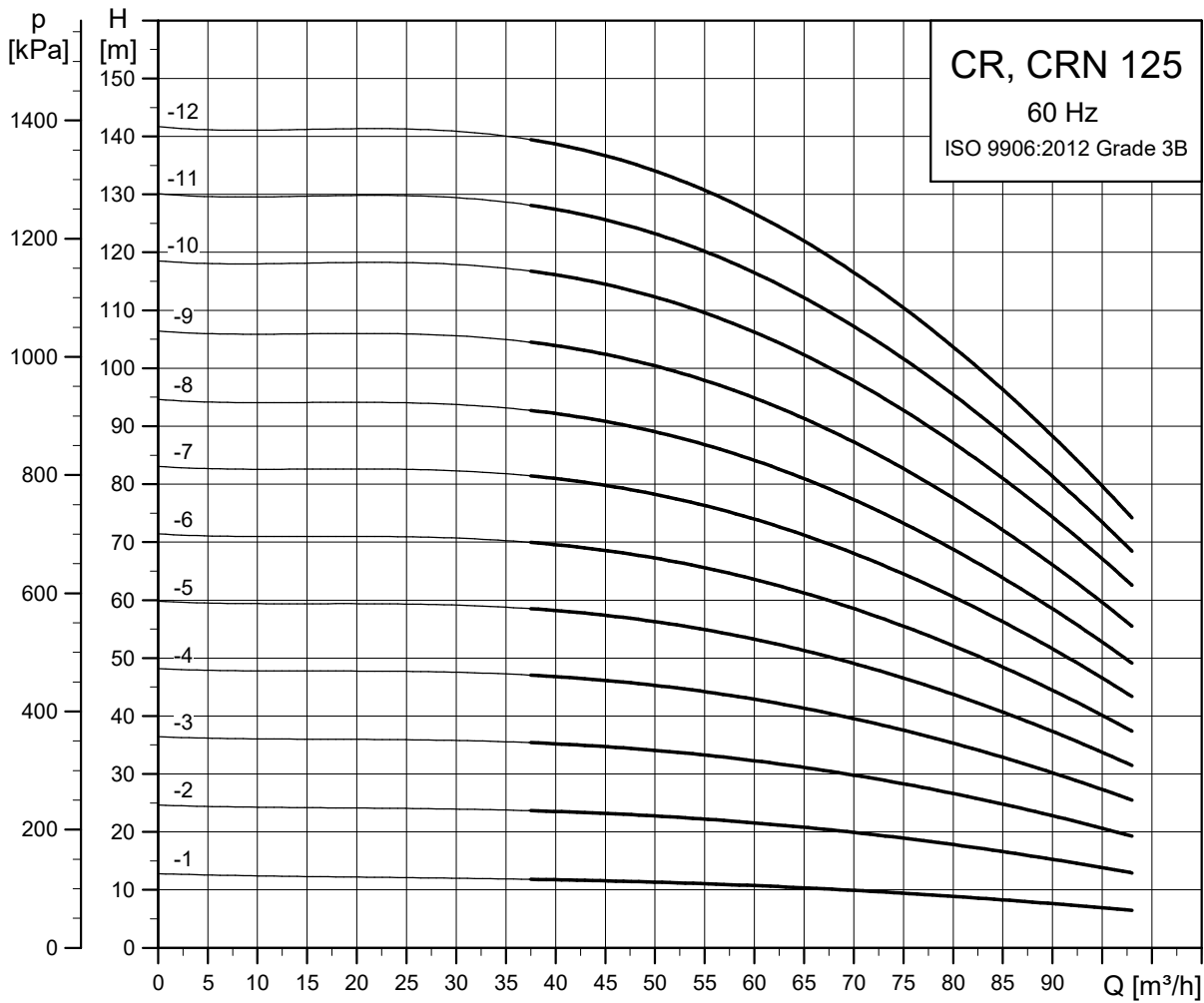

TM076984

CR pumps with 4-pole motor, 60 Hz: CR, CRN 155

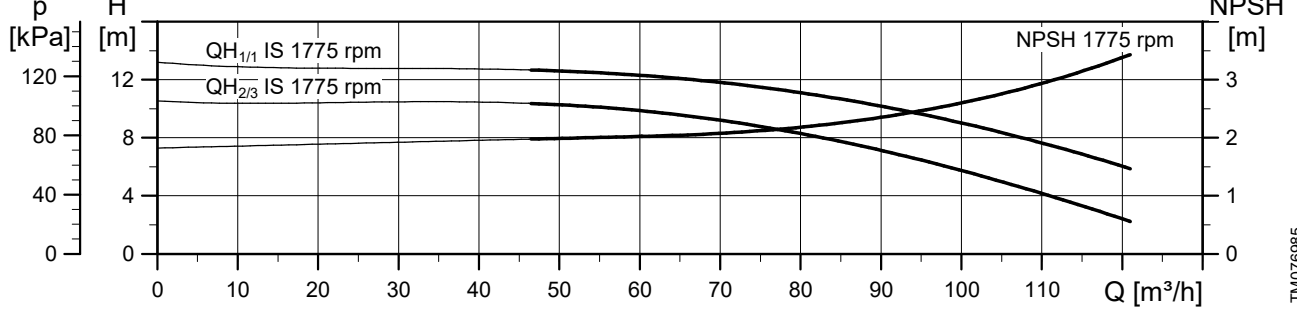
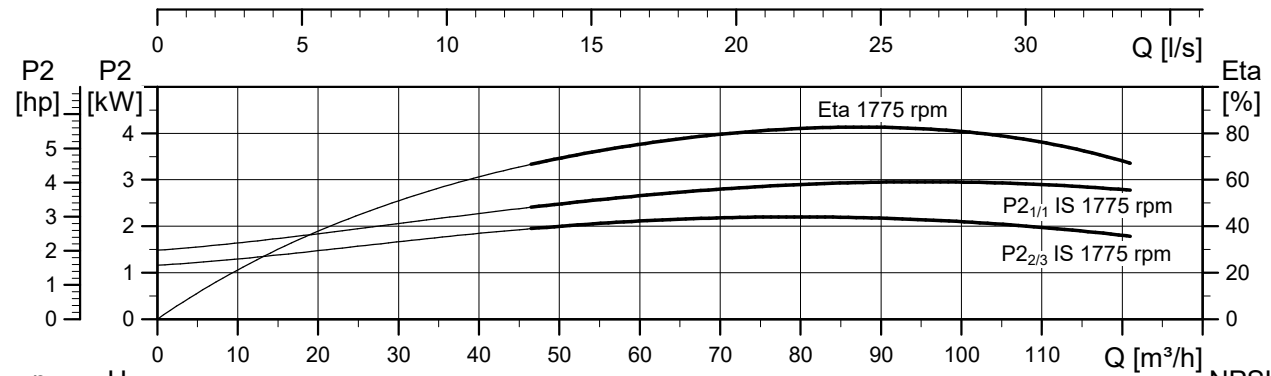
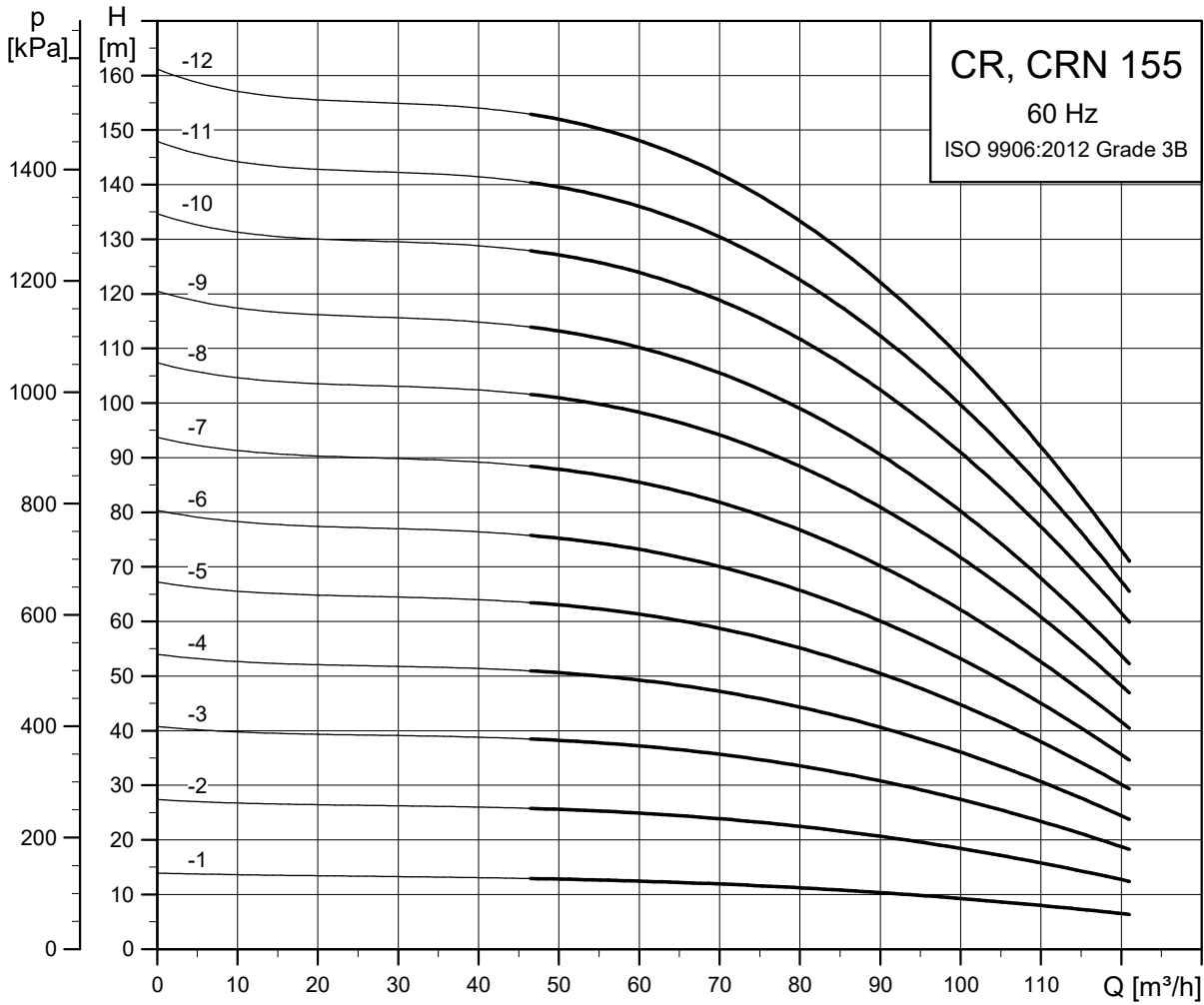

TM076985

CR pumps with 4-pole motor, 60 Hz: CR, CRN 185

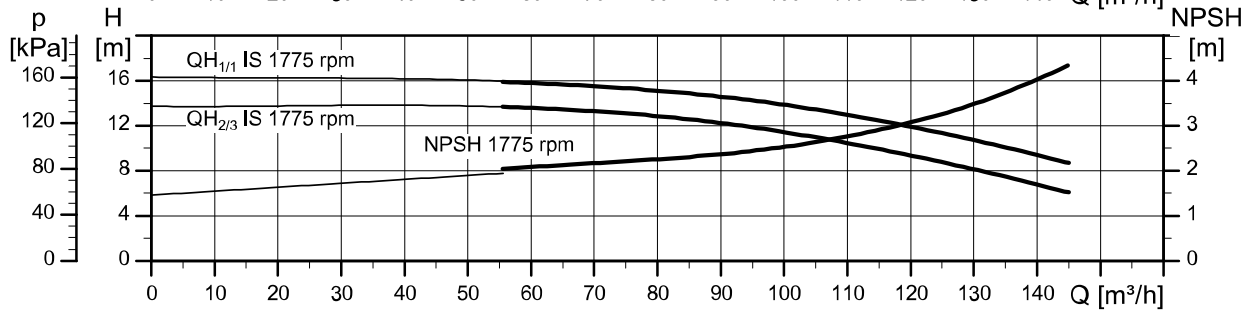
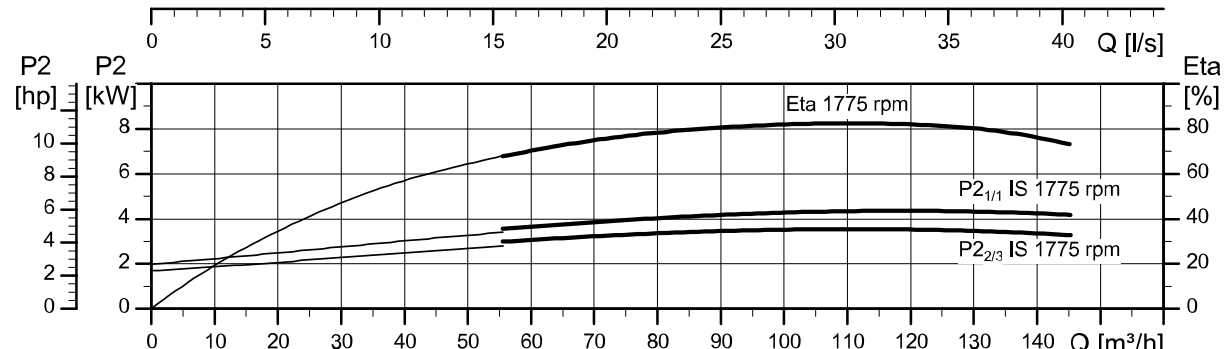
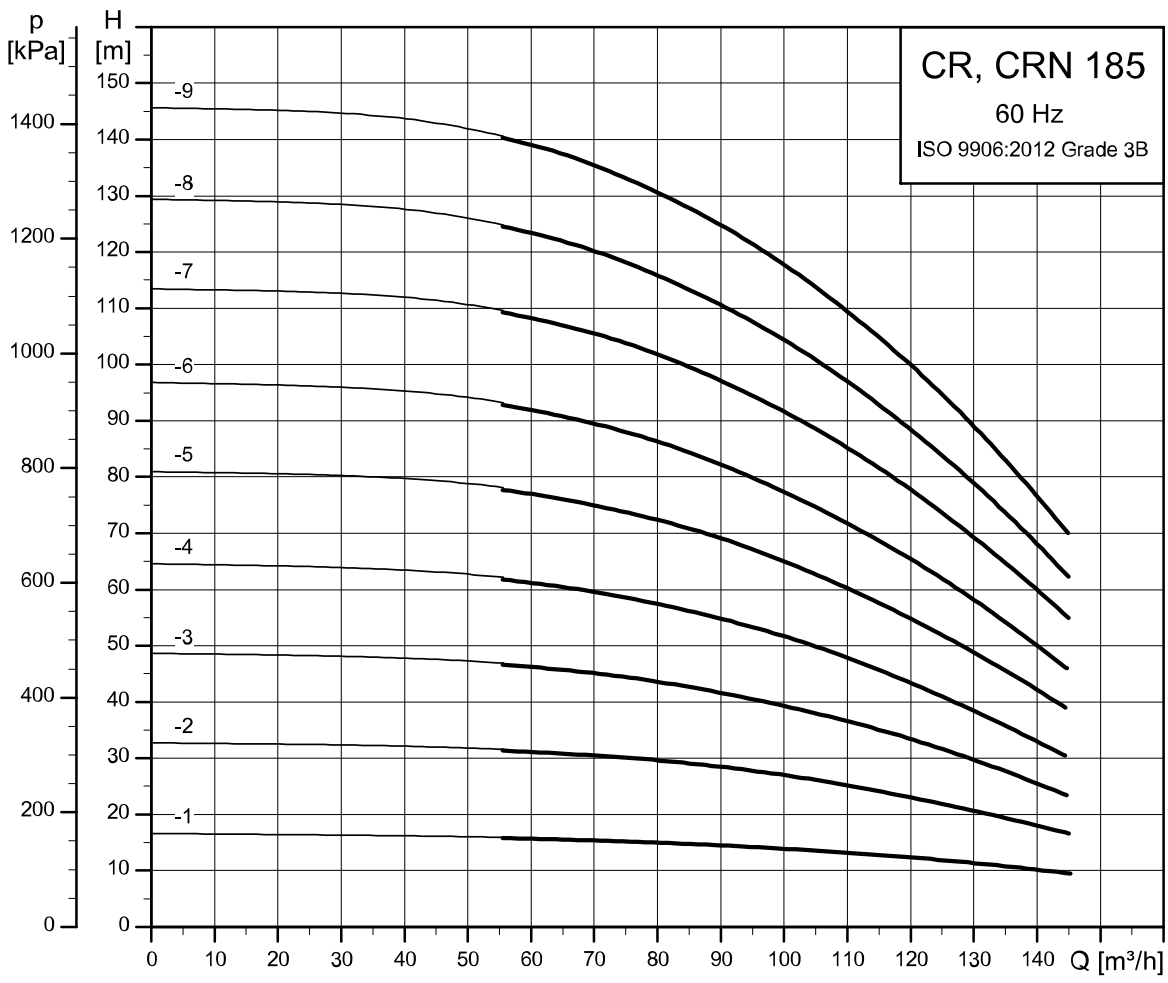

TM076986

CR pumps with 4-pole motor, 60 Hz: CR, CRN 215

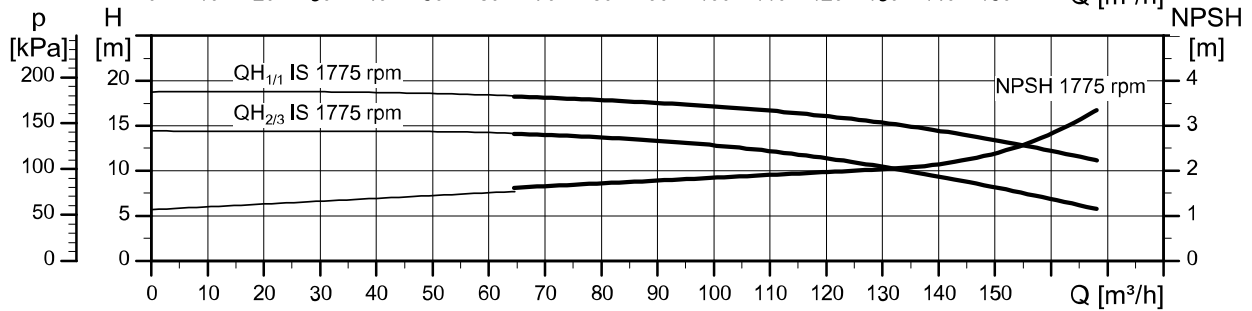
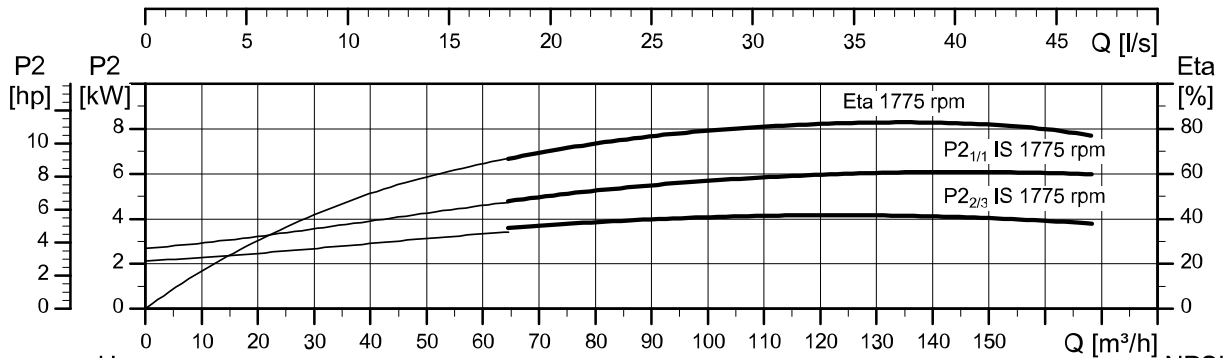
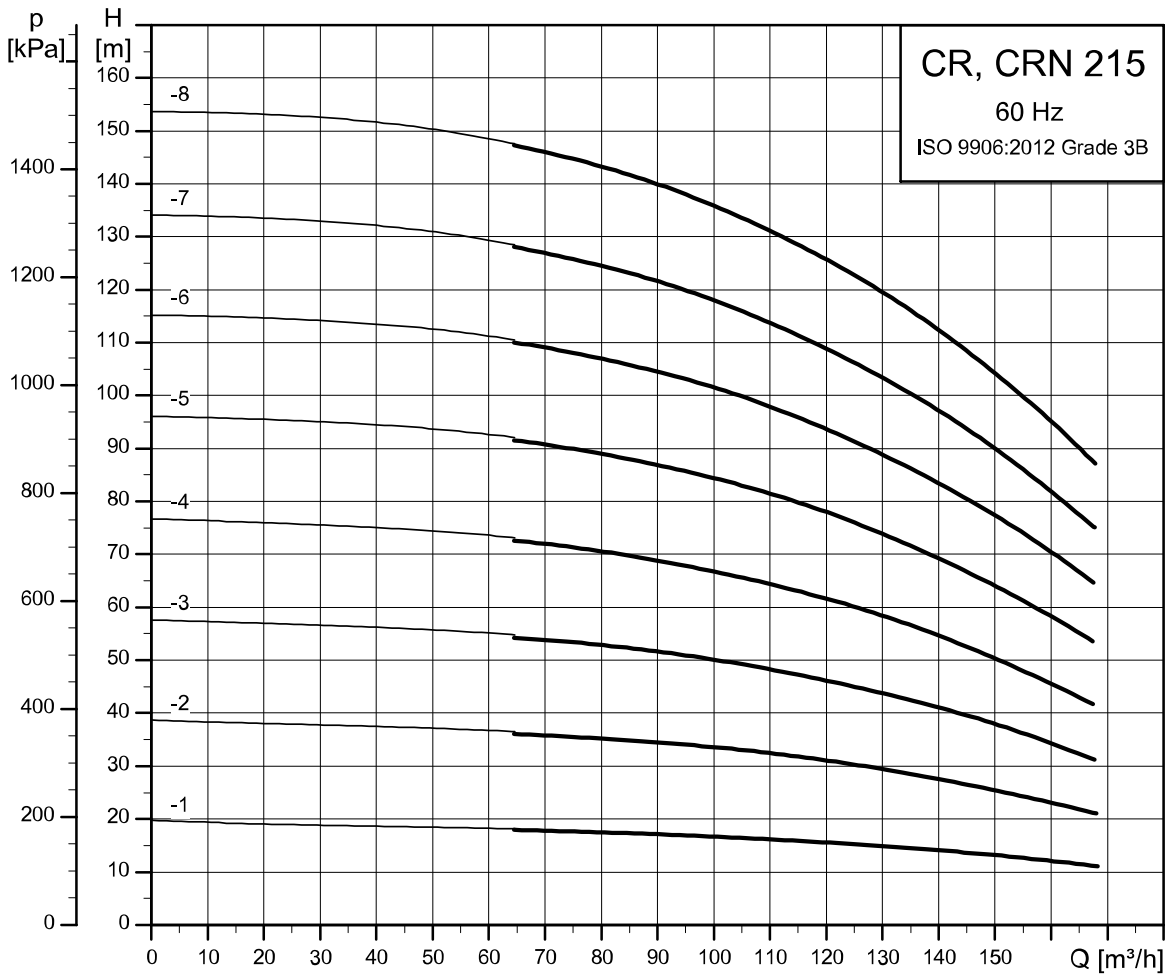

TM078943

CR pumps with 4-pole motor, 60 Hz: CR, CRN 255

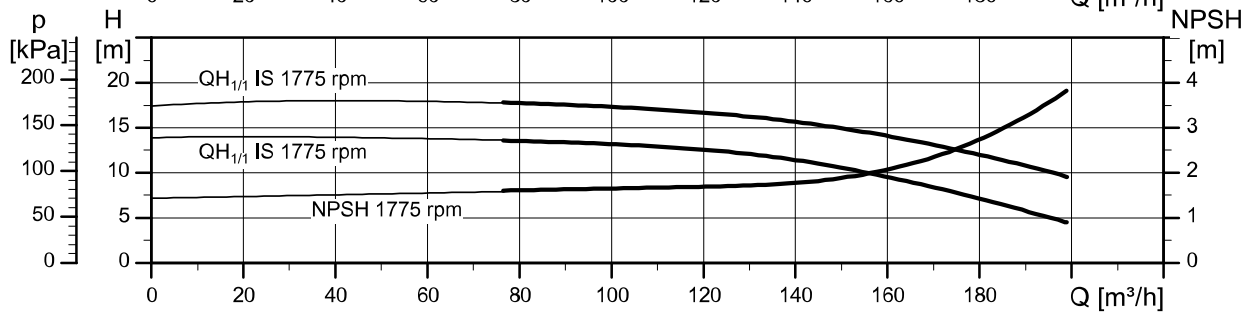
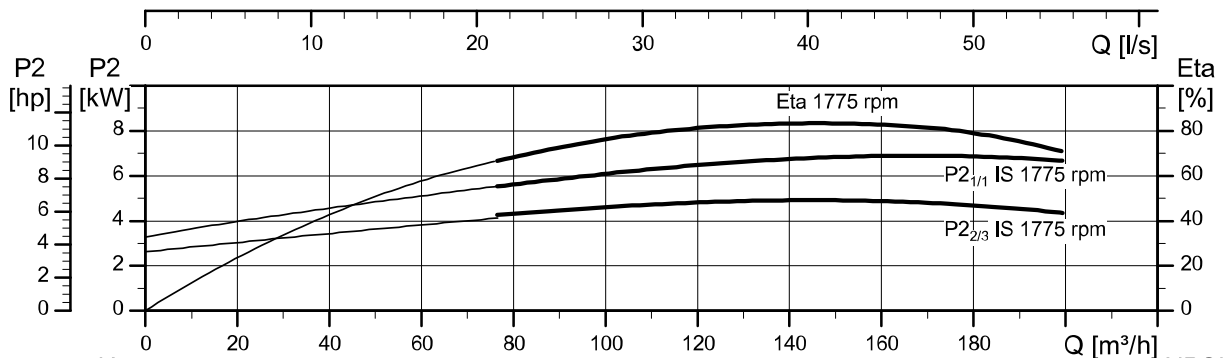
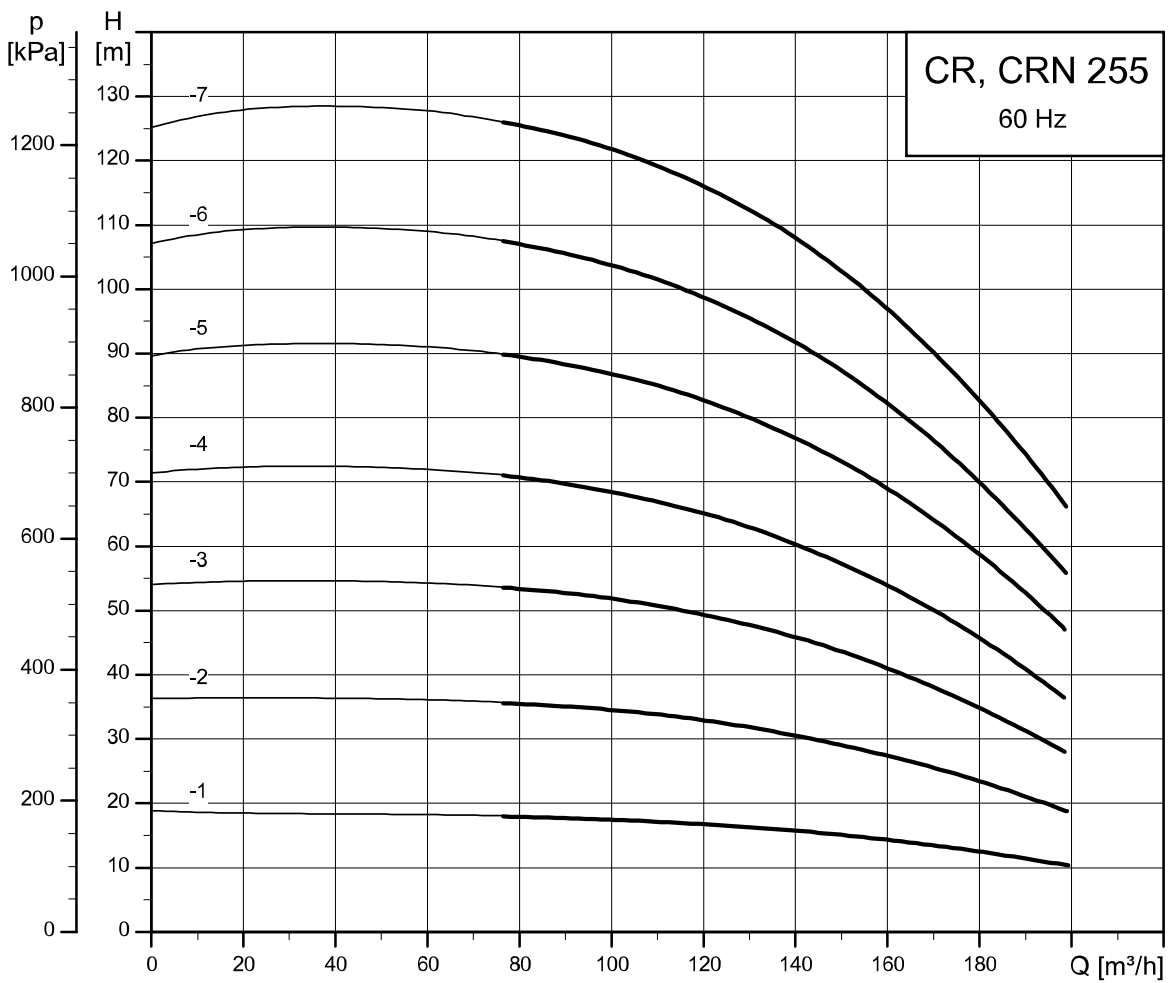

TM080279

Preliminary calculated performance curves.

13. Technical data

Dimensional drawings for CR pumps

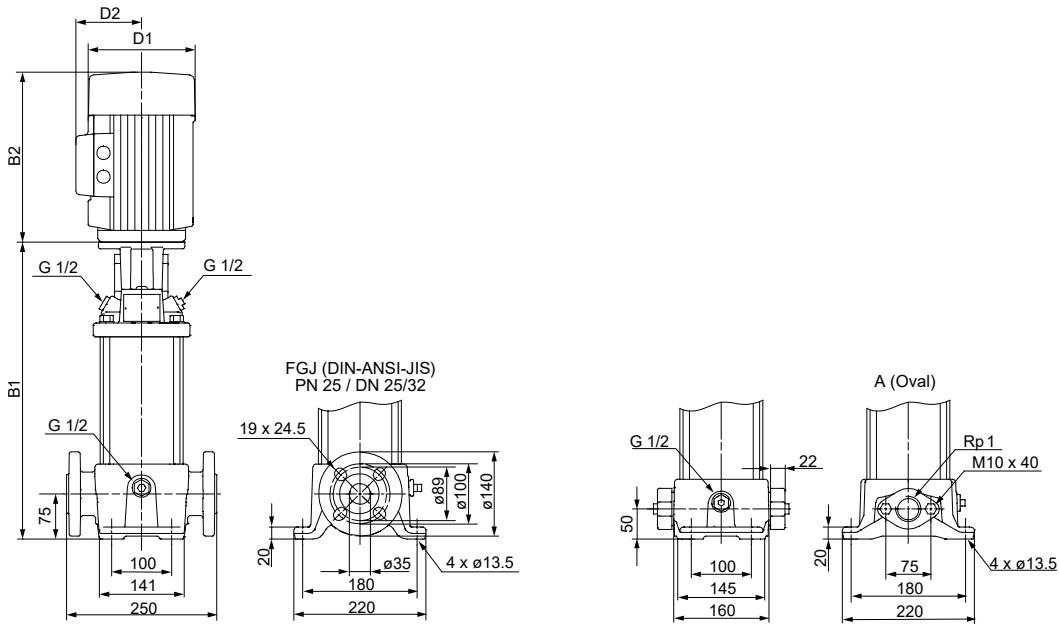

TM031721

CR 1, CR 3

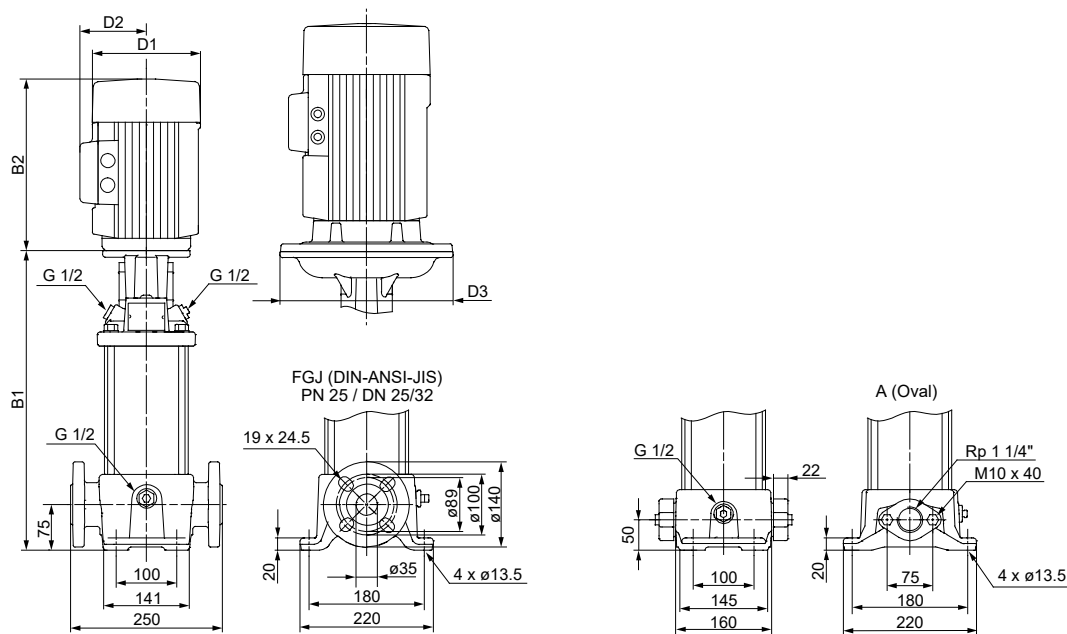

TM031723

CR 5

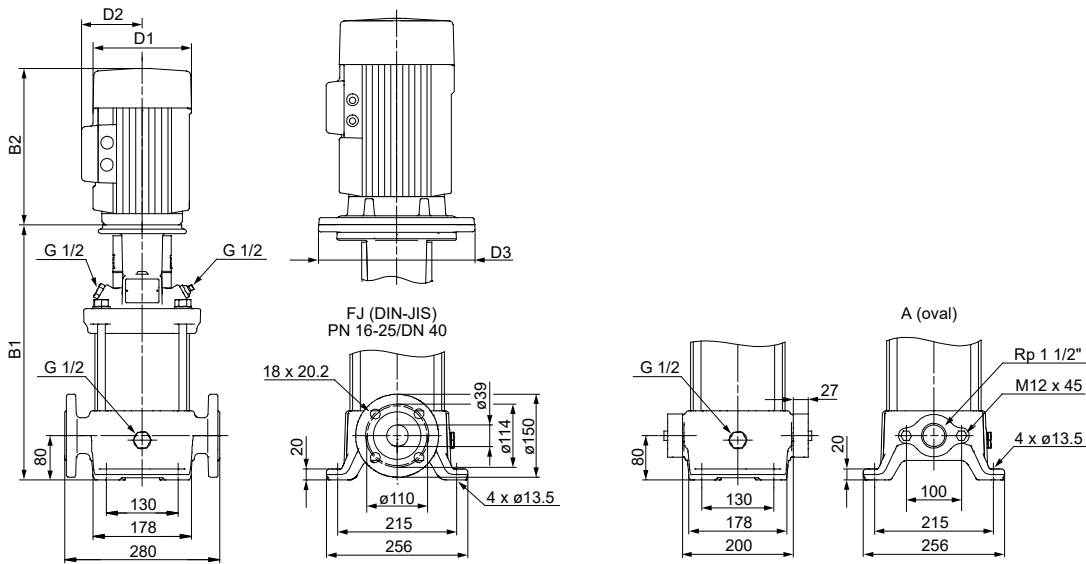

TM031725

CR 10

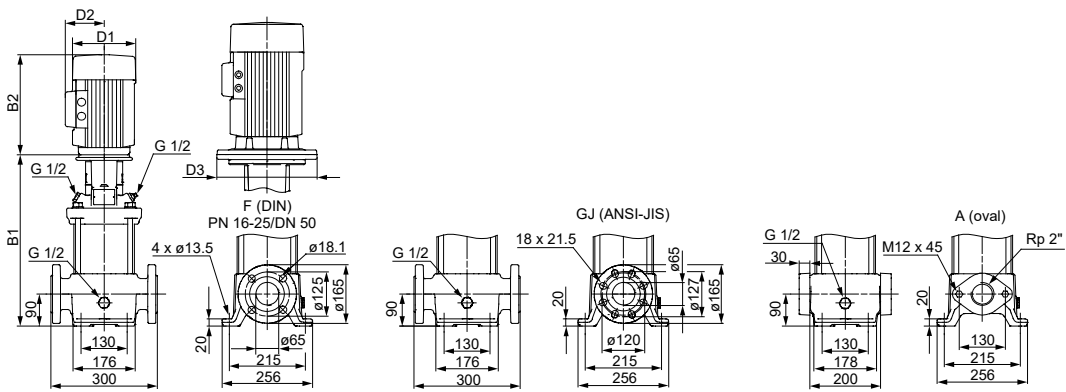

TM031727

CR 15, CR 20

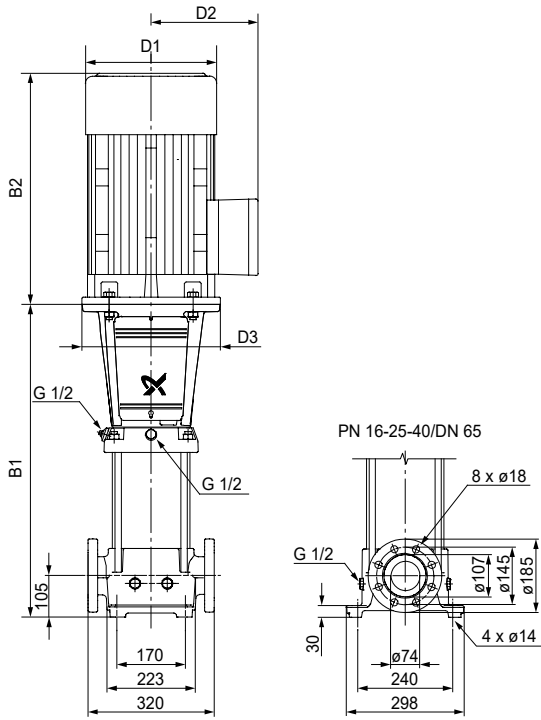

CR 32

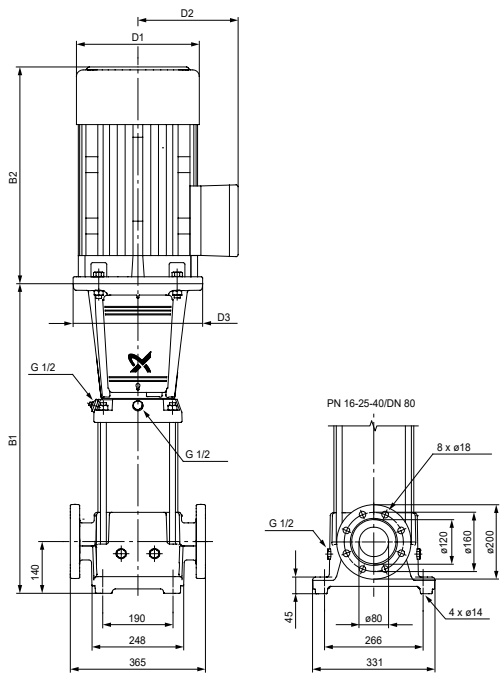

CR 45

TM011749

TM011751

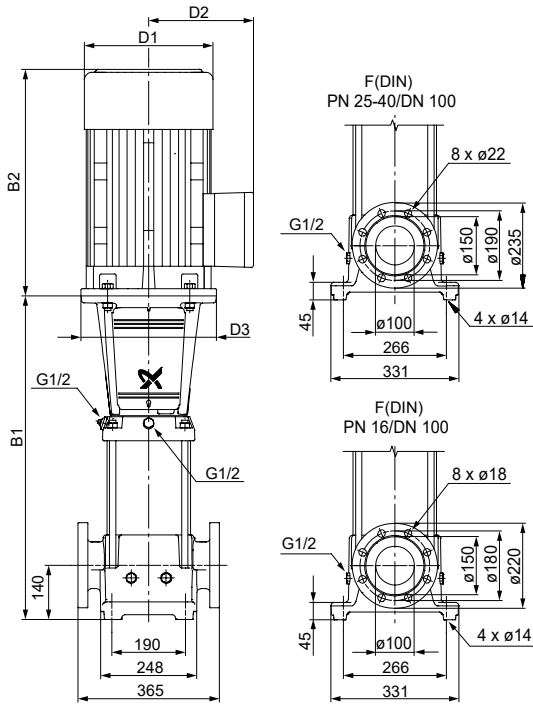

CR 64

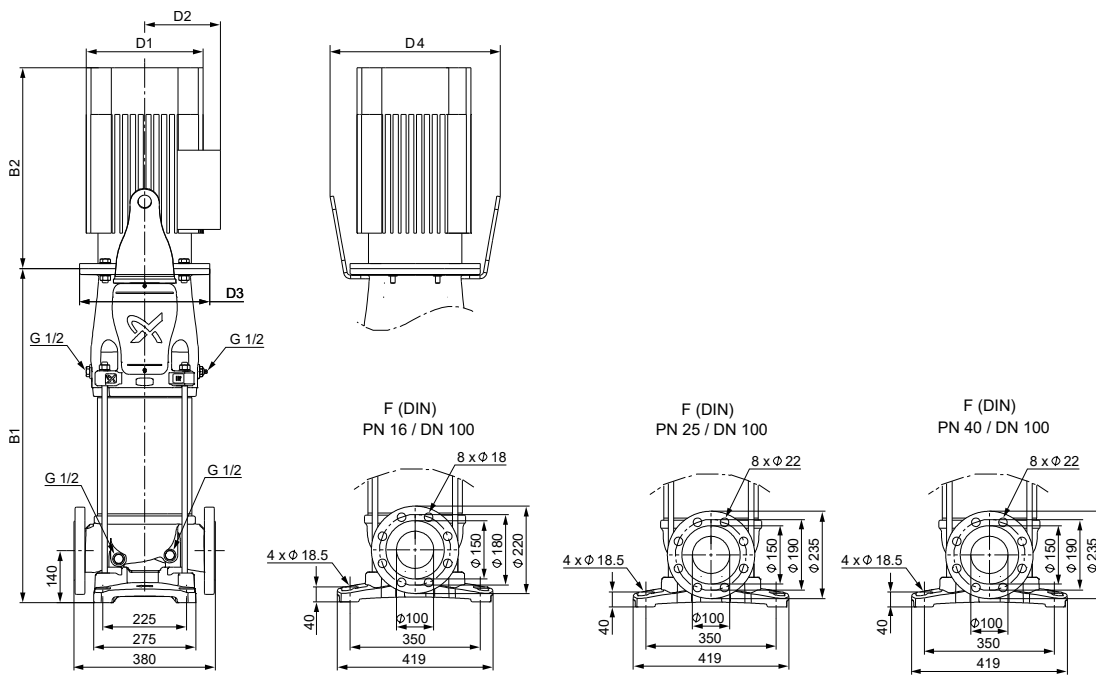

CR 95

TM011753

TM080551

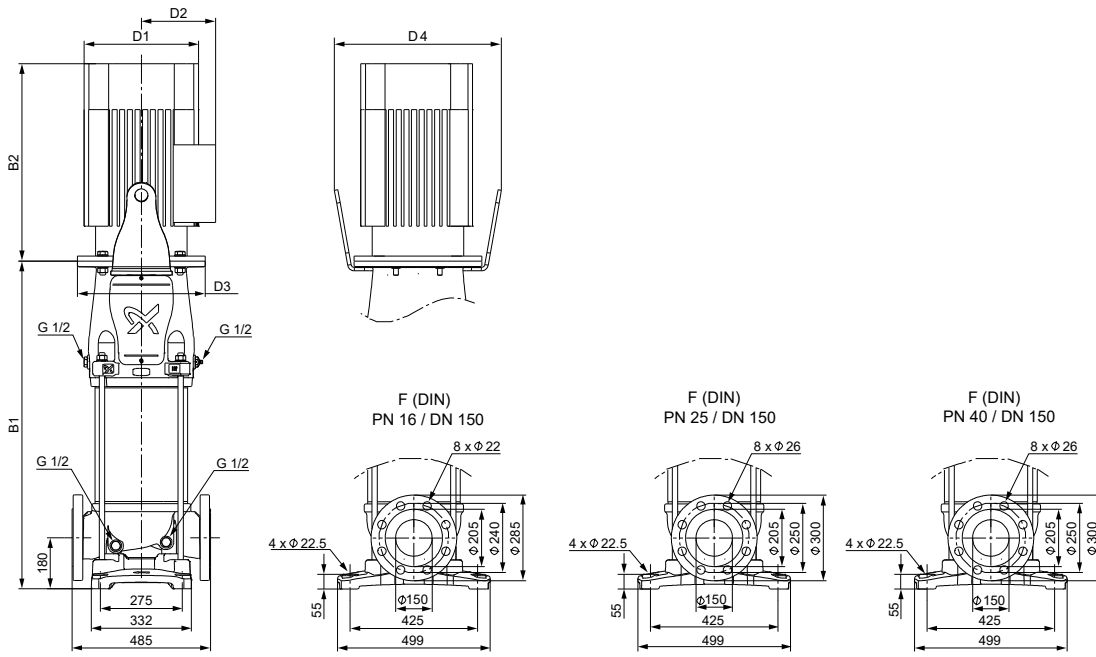

TM080549

CR 125, CR 155

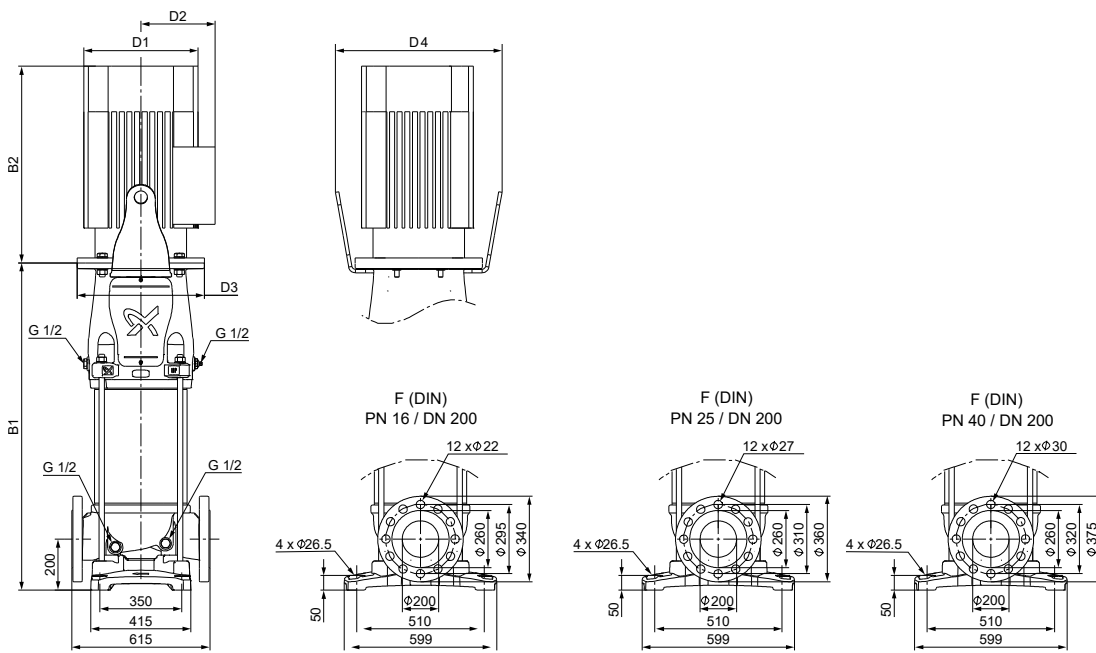

TM076604

CR 185, CR 215, CR 255

CR low-NPSH pump

Dimensions and weights

CR 3 low-NPSH pumps, 50 Hz

Pump type	Motor P2 [kW]	CR								
		Dimension [mm]						Net weight [kg]		
		DIN flange		Oval flange		D1	D2	D3	DIN flange	Oval flange
B1	B1 + B2	B1	B1 + B2							
CR 3-3	0.37	279	470	254	445	141	109	-	23	18
CR 3-4	0.37	297	488	272	463	141	109	-	23	19
CR 3-5	0.55	315	506	290	481	141	109	-	24.5	19.5
CR 3-6	0.55	333	524	308	499	141	109	-	25	20
CR 3-7	0.55	351	542	326	517	141	109	-	25	21
CR 3-8	0.75	375	606	350	581	141	109	-	27	23
CR 3-9	0.75	393	624	368	599	141	109	-	28	23
CR 3-10	0.75	411	642	386	617	141	109	-	28	24
CR 3-11	1.1	429	680	404	635	141	109	-	31	26
CR 3-12	1.1	447	698	422	653	141	109	-	31	26
CR 3-13	1.1	465	716	440	671	141	109	-	31	27
CR 3-15	1.1	501	752	476	707	141	109	-	32	28
CR 3-17	1.5	553	834	528	809	178	110	-	40	36
CR 3-19	1.5	589	870	564	845	178	110	-	41	37
CR 3-21	2.2	625	946	600	921	178	110	-	42	38
CR 3-23	2.2	661	982	636	957	178	110	-	43	39
CR 3-25	2.2	697	1018	-	-	178	110	-	44	-
CR 3-27	2.2	733	1054	-	-	178	110	-	45	-
CR 3-29	2.2	769	1090	-	-	178	110	-	46	-
CR 3-31	3	809	1144	-	-	198	120	-	51	-
CR 3-33	3	845	1180	-	-	198	120	-	51	-
CR 3-36	3	899	1234	-	-	198	120	-	53	-

CR 3 low-NPSH pumps are also available as CRI and CRN pumps with PJE and CA connection.

CR 5 low-NPSH pumps, 50 Hz

Pump type	Motor P2 [kW]	CR								
		Dimension [mm]						Net weight [kg]		
		DIN flange		Oval flange		D1	D2	D3	DIN flange	Oval flange
B1	B1 + B2	B1	B1 + B2							
CR 5-4	0.75	339	570	308	539	141	109	-	26.5	21.5
CR 5-5	0.75	366	597	341	572	141	109	-	27	22
CR 5-6	1.1	393	644	368	599	141	109	-	30	25
CR 5-7	1.1	420	671	395	626	141	109	-	30	26
CR 5-8	1.1	447	698	422	653	141	109	-	31	26
CR 5-9	1.5	490	771	465	746	178	110	-	38	34
CR 5-10	1.5	517	798	492	773	178	110	-	39	34
CR 5-11	2.2	544	865	519	840	178	110	-	40	36
CR 5-12	2.2	571	892	546	867	178	110	-	41	36
CR 5-13	2.2	598	919	573	894	178	110	-	41	37
CR 5-14	2.2	625	946	600	921	178	110	-	42	37
CR 5-15	2.2	652	973	627	948	178	110	-	43	38
CR 5-16	2.2	679	1000	654	975	178	110	-	43	38
CR 5-18	3	737	1072	712	1047	198	120	-	48	44
CR 5-20	3	791	1126	766	1101	198	120	-	50	45
CR 5-22	4	845	1217	820	1194	220	134	-	62	56
CR 5-24	4	899	1271	-	-	220	134	-	63	-

Pump type	Motor P2 [kW]	CR								
		Dimension [mm]				Net weight [kg]				
		DIN flange		Oval flange		D1	D2	D3	DIN flange	Oval flange
		B1	B1 + B2	B1	B1 + B2					
CR 5-26	4	953	1325	-	-	220	134	-	64	-
CR 5-29	4	1034	1406	-	-	220	134	-	66	-
CR 5-32	5.5	1145	1536	-	-	220	134	300	82	-
CR 5-36	5.5	1253	1644	-	-	220	134	300	84	-

CR 5 low-NPSH pumps are also available as CRI and CRN pumps with PJE and CA connection.

CR 10 low-NPSH pumps, 50 Hz

Pump type	Motor P2 [kW]	CR								
		Dimension [mm]				Net weight [kg]				
		DIN flange		Oval flange		D1	D2	D3	DIN flange	Oval flange
		B1	B1 + B2	B1	B1 + B2					
CR 10-3	1.1	407	658	407	658	141	109	-	39	37
CR 10-4	1.5	423	704	423	704	178	110	-	47	45
CR 10-5	2.2	453	774	453	734	178	110	-	49	46
CR 10-6	2.2	483	804	483	764	178	110	-	50	47
CR 10-7	3	518	853	518	853	198	120	-	55	52
CR 10-8	3	548	883	548	883	198	120	-	56	53
CR 10-9	4	578	950	578	950	220	134	-	68	65
CR 10-10	4	608	980	608	980	220	134	-	69	66
CR 10-12	4	668	1040	668	1040	220	134	-	71	69
CR 10-14	5.5	760	1151	760	1151	220	134	300	94	91
CR 10-16	5.5	820	1211	820	1211	220	134	300	96	93
CR 10-18	7.5	880	1259	-	-	220	134	300	113	-
CR 10-20	7.5	940	1319	-	-	220	134	300	115	-
CR 10-22	7.5	1000	1379	-	-	220	134	300	117	-

CR 10 low-NPSH pumps are also available as CRI and CRN pumps with PJE and CA connection.

CR 15 low-NPSH pumps, 50 Hz

Pump type	Motor P2 [kW]	CR								
		Dimension [mm]				Net weight [kg]				
		DIN flange		Oval flange		D1	D2	D3	DIN flange	Oval flange
		B1	B1 + B2	B1	B1 + B2					
CR 15-2	3	420	755	415	750	198	120	-	54	53
CR 15-3	4	465	837	465	837	220	134	-	66	65
CR 15-4	4	510	882	510	882	220	134	-	68	67
CR 15-5	5.5	587	978	555	946	220	134	-	75	74
CR 15-6	5.5	632	1023	632	1023	220	134	300	91	90
CR 15-7	7.5	677	1056	677	1068	220	134	300	108	107
CR 15-8	7.5	722	1101	-	-	220	134	300	109	-
CR 15-9	11	844	1315	-	-	314	204	350	128	-
CR 15-10	11	889	1360	-	-	314	204	350	132	-
CR 15-12	11	979	1450	-	-	314	204	350	136	-
CR 15-14	15	1069	1540	-	-	314	204	350	177	-
CR 15-17	15	1204	1675	-	-	314	204	350	177	-

CR 15 low-NPSH pumps are also available as CRI and CRN pumps with PJE and CA connection.

CR 20 low-NPSH pumps, 50 Hz

Pump type	Motor P2 [kW]	CR								
		Dimension [mm]				Net weight [kg]				
		DIN flange		Oval flange		D1	D2	D3	DIN flange	Oval flange
		B1	B1 + B2	B1	B1 + B2					
CR 20-2	3	420	755	415	736	178	110	-	50	49
CR 20-3	4	465	837	465	837	220	134	-	66	65
CR 20-4	5.5	542	933	542	933	220	134	300	88	87
CR 20-5	7.5	587	966	587	978	220	134	300	102	101
CR 20-6	7.5	632	1011	632	1023	220	134	300	105	104
CR 20-7	11	754	1225	677	1148	314	204	300	139	138
CR 20-8	11	799	1270	-	-	314	204	350	129	-
CR 20-10	11	889	1360	-	-	314	204	350	132	-
CR 20-12	15	979	1450	-	-	314	204	350	168	-
CR 20-14	15	1069	1540	-	-	314	204	350	172	-
CR 20-17	18.5	1204	1719	-	-	314	204	350	199	-

CR 20 low-NPSH pumps are also available as CRI and CRN pumps with PJE and CA connection.

CR 32 low-NPSH pumps, 50 Hz

Pump type	Motor P2 [kW]	CR					
		Dimension [mm]			Net weight [kg]		
		DIN flange		D1	D2	D3	DIN flange
		B1	B1 + B2				
CR 32-2	4	575	947	220	134	158	87
CR 32-3-2	5.5	645	1036	220	134	298	107
CR 32-3	5.5	645	1036	220	134	298	107
CR 32-4-2	7.5	715	1094	220	134	298	129
CR 32-4	7.5	715	1094	220	134	298	129
CR 32-5-2	11	895	1366	314	204	350	157
CR 32-5	11	895	1366	314	204	350	157
CR 32-6-2	11	965	1436	314	204	350	160
CR 32-6	11	965	1436	314	204	350	160
CR 32-7-2	15	1035	1506	314	204	350	195
CR 32-7	15	1035	1506	314	204	350	195
CR 32-8-2	15	1105	1576	314	204	350	198
CR 32-8	15	1105	1576	314	204	350	198
CR 32-9-2	18.5	1175	1690	314	204	350	223
CR 32-9	18.5	1175	1690	314	204	350	223
CR 32-10-2	18.5	1245	1760	314	204	350	226
CR 32-10	18.5	1245	1760	314	204	350	226
CR 32-11-2	22	1315	1856	314	204	350	247
CR 32-11	22	1315	1856	314	204	350	247
CR 32-12-2	22	1385	1926	314	204	350	251
CR 32-12	22	1385	1926	314	204	350	251
CR 32-13-2	30	1455	2066	415	300	400	322
CR 32-13	30	1455	2066	415	300	400	322
CR 32-14-2	30	1525	2136	415	300	400	325
CR 32-14	30	1525	2136	415	300	400	325

CR 32 low-NPSH pumps are also available as CRN pumps with PJE connection.

CR 45 low-NPSH pumps, 50 Hz

Pump type	Motor P2 [kW]	CR					Net weight [kg]
		Dimension [mm]			Net weight [kg]		
		DIN flange		D1	D2	D3	
B1	B1 + B2						
CR 45-2	7.5	639	1018	220	134	298	122
CR 45-3-2	11	829	1300	314	204	350	151
CR 45-3	11	829	1300	314	204	350	151
CR 45-4-2	15	909	1380	314	204	350	189
CR 45-4	15	909	1380	314	204	350	189
CR 45-5-2	18.5	989	1504	314	204	350	216
CR 45-5	18.5	989	1504	314	204	350	216
CR 45-6-2	22	1069	1610	314	204	350	237
CR 45-6	22	1069	1610	314	204	350	237
CR 45-7-2	30	1149	1760	415	300	400	321
CR 45-7	30	1149	1760	415	300	400	321
CR 45-8-2	30	1229	1840	415	300	400	336
CR 45-8	30	1229	1840	415	300	400	336
CR 45-9-2	30	1309	1920	415	300	400	341
CR 45-9	37	1309	1945	415	300	400	361
CR 45-10-2	37	1389	2025	415	300	400	366
CR 45-10	37	1389	2025	415	300	400	366
CR 45-11-2	45	1469	2177	442	325	450	478
CR 45-11	45	1469	2177	442	325	450	478
CR 45-12-2	45	1549	2257	442	325	450	483
CR 45-12	45	1549	2257	442	325	450	483
CR 45-13-2	45	1629	2337	442	325	450	488

CR 45 low-NPSH pumps are also available as CRN pumps with PJE connection.

CR 64 low-NPSH pumps, 50 Hz

Pump type	Motor P2 [kW]	CR					Net weight [kg]
		Dimension [mm]			Net weight [kg]		
		DIN flange		D1	D2	D3	
B1	B1 + B2						
CR 64-2-1	11	754	1225	314	204	350	151
CR 64-2	11	754	1225	314	204	350	151
CR 64-3-2	15	836	1307	314	204	350	194
CR 64-3-1	15	836	1307	314	204	350	194
CR 64-3	18.5	836	1351	314	204	350	216
CR 64-4-2	18.5	919	1434	314	204	350	226
CR 64-4-1	22	919	1460	314	204	350	242
CR 64-4	22	919	1460	314	204	350	242
CR 64-5-2	30	1001	1612	415	300	400	316
CR 64-5-1	30	1001	1612	415	300	400	316
CR 64-5	30	1001	1612	415	300	400	316
CR 64-6-2	30	1084	1695	415	300	400	336
CR 64-6-1	37	1084	1720	415	300	400	356
CR 64-6	37	1084	1720	415	300	400	356
CR 64-7-2	37	1166	1802	415	300	400	376
CR 64-7-1	37	1166	1802	415	300	400	376
CR 64-7	45	1166	1874	442	325	450	440
CR 64-8-2	45	1249	1957	442	325	450	473
CR 64-8-1	45	1249	1957	442	325	450	473

CR 64 low-NPSH pumps are also available as CRN pumps with PJE connection.

CR 3 low-NPSH pumps, 60 Hz

Pump type	Motor P2 [kW]	CR								
		Dimension [mm]				Net weight [kg]				
		DIN flange		Oval flange		D1	D2	D3	DIN flange	Oval flange
B1	B1 + B2	B1	B1 + B2							
CR 3-3	0.55	279	470	254	445	141	109	-	24	19
CR 3-4	0.55	297	488	272	463	141	109	-	24	19
CR 3-5	0.75	321	552	296	527	141	109	-	26	22
CR 3-6	1.1	339	590	314	545	141	109	-	29	24
CR 3-7	1.1	357	608	332	563	141	109	-	29	24
CR 3-8	1.1	375	626	350	581	141	109	-	29	25
CR 3-9	1.5	409	690	384	665	178	110	-	37	32
CR 3-10	1.5	427	708	402	683	178	110	-	37	33
CR 3-11	1.5	445	726	420	701	178	110	-	38	33
CR 3-12	2.2	463	784	438	759	178	110	-	39	34
CR 3-13	2.2	481	802	456	777	178	110	-	39	34
CR 3-15	2.2	517	838	492	813	178	110	-	40	35
CR 3-17	2.2	553	874	528	849	178	110	-	41	36
CR 3-19	3	593	928	-	-	198	120	-	46	-
CR 3-21	3	629	964	-	-	198	120	-	47	-
CR 3-23	3	665	1000	-	-	198	120	-	47	-
CR 3-25	4	701	1073	-	-	220	134	-	59	-

CR 3 low-NPSH pumps are also available as CRI and CRN pumps with PJE and CA connection.

CR 5 low-NPSH pumps, 60 Hz

Pump type	Motor P2 [kW]	CR								
		Dimension [mm]				Net weight [kg]				
		DIN flange		Oval flange		D1	D2	D3	DIN flange	Oval flange
B1	B1 + B2	B1	B1 + B2							
CR 5-4	1.1	339	590	314	545	141	109	-	28	24
CR 5-5	1.5	382	663	357	638	178	110	-	36	32
CR 5-6	2.2	409	730	384	705	178	110	-	37	33
CR 5-7	2.2	436	757	411	732	178	110	-	38	33
CR 5-8	2.2	463	784	438	759	178	110	-	38	34
CR 5-9	2.2	490	811	465	786	178	110	-	39	34
CR 5-10	3	521	856	496	831	198	120	-	44	39
CR 5-11	3	548	883	523	858	198	120	-	44	40
CR 5-12	3	575	910	550	885	198	120	-	45	40
CR 5-13	4	602	974	577	949	220	134	-	56	52
CR 5-14	4	629	1001	604	976	220	134	-	57	53
CR 5-15	4	656	1028	631	1003	220	134	-	58	53
CR 5-16	4	683	1055	658	1030	220	134	-	58	54
CR 5-18	5.5	767	1158	-	-	220	134	300	74	-
CR 5-20	5.5	821	1212	-	-	220	134	300	75	-
CR 5-22	5.5	875	1266	-	-	220	134	300	76	-
CR 5-24	7.5	929	1308	-	-	220	134	300	79	-

CR 5 low-NPSH pumps are also available as CRI and CRN pumps with PJE and CA connection.

CR 10 low-NPSH pumps, 60 Hz

Pump type	Motor P2 [kW]	CR								
		Dimension [mm]						Net weight [kg]		
		DIN flange		Oval flange		D1	D2	D3	DIN flange	Oval flange
		B1	B1 + B2	B1	B1 + B2					
CR 10-3	2.2	423	744	423	744	198	120	-	47	44
CR 10-4	3	428	763	428	763	198	120	-	52	49
CR 10-5	4	458	830	458	830	220	134	-	64	61
CR 10-6	4	488	860	488	860	220	134	-	65	62
CR 10-7	5.5	550	941	550	941	220	134	300	87	84
CR 10-8	5.5	580	971	580	971	220	134	300	88	85
CR 10-9	5.5	610	1001	610	1001	220	134	300	89	86
CR 10-10	7.5	640	1019	640	1019	220	134	300	104	101
CR 10-12	7.5	700	1079	-	-	220	134	300	106	-
CR 10-14	11	837	1308	-	-	314	204	350	129	-
CR 10-16	11	897	1368	-	-	314	204	350	131	-
CR 10-17	11	957	1428	-	-	314	204	350	133	-

CR 10 low-NPSH pumps are also available as CRI and CRN pumps with PJE and CA connection.

CR 15 low-NPSH pumps, 60 Hz

Pump type	Motor P2 [kW]	CR								
		Dimension [mm]						Net weight [kg]		
		DIN flange		Oval flange		D1	D2	D3	DIN flange	Oval flange
		B1	B1 + B2	B1	B1 + B2					
CR 15-2	5.5	452	843	420	811	220	134	-	71	70
CR 15-3	5.5	497	888	465	856	220	134	-	72	71
CR 15-4	7.5	542	921	542	921	220	134	300	103	102
CR 15-5	11	664	1135	587	1058	314	204	300	136	135
CR 15-6	11	709	1180	-	-	314	204	350	126	-
CR 15-7	15	754	1225	-	-	314	204	350	152	-
CR 15-8	15	799	1270	-	-	314	204	350	154	-
CR 15-9	15	844	1315	-	-	314	204	350	163	-
CR 15-10	18.5	889	1404	-	-	314	204	350	175	-
CR 15-12	18.5	979	1494	-	-	314	204	350	190	-

CR 15 low-NPSH pumps are also available as CRI and CRN pumps with PJE and CA connection.

CR 20 low-NPSH pumps, 60 Hz

Pump type	Motor P2 [kW]	CR								
		Dimension [mm]						Net weight [kg]		
		DIN flange		Oval flange		D1	D2	D3	DIN flange	Oval flange
		B1	B1 + B2	B1	B1 + B2					
CR 20-2	5.5	452	843	420	811	220	134	-	71	70
CR 20-3	7.5	497	876	497	876	220	134	300	102	101
CR 20-4	11	619	1090	542	1013	314	204	350	134	133
CR 20-5	11	664	1135	664	1135	314	204	350	124	123
CR 20-6	15	709	1180	-	-	314	204	350	151	-
CR 20-7	15	754	1225	-	-	314	204	350	159	-
CR 20-8	18.5	799	1314	-	-	314	204	350	171	-

CR 20 low-NPSH pumps are also available as CRI and CRN pumps with PJE and CA connection.

CR 32 low-NPSH pumps, 60 Hz

Pump type	Motor P2 [kW]	CR					Net weight [kg]
		Dimension [mm]				DIN flange	
		DIN flange		D1	D2		
B1	B1 + B2						
CR 32-2-1	5.5	575	966	220	148	298	98
CR 32-2	7.5	575	954	220	134	298	112
CR 32-3-2	11	755	1226	314	204	350	146
CR 32-3	11	755	1226	314	204	350	146
CR 32-4-2	11	825	1296	314	204	350	154
CR 32-4	15	825	1296	314	204	350	186
CR 32-5-2	15	895	1366	314	204	350	189
CR 32-5	18.5	895	1410	314	204	350	211
CR 32-6-2	18.5	965	1480	314	204	350	214
CR 32-6	18.5	965	1480	314	204	350	214
CR 32-7-2	22	1035	1576	314	204	350	233
CR 32-7	22	1035	1576	314	204	350	233
CR 32-8-2	30	1105	1716	415	300	400	305
CR 32-8	30	1105	1716	415	300	400	305
CR 32-9-2	30	1175	1786	415	300	400	308
CR 32-9	30	1175	1786	415	300	400	308
CR 32-10-2	30	1245	1856	415	300	400	311

CR 32 low-NPSH pumps are also available as CRN pumps with PJE connection.

CR 45 low-NPSH pumps, 60 Hz

Pump type	Motor P2 [kW]	CR					Net weight [kg]
		Dimension [mm]				DIN flange	
		DIN flange		D1	D2		
B1	B1 + B2						
CR 45-2-1	11	749	1220	314	204	350	147
CR 45-2	15	749	1220	314	204	350	179
CR 45-3-2	18.5	829	1344	314	204	350	205
CR 45-3-1	18.5	829	1344	314	204	350	205
CR 45-3	18.5	829	1344	314	204	350	205
CR 45-4-2	22	909	1450	314	204	350	227
CR 45-4-1	30	909	1520	415	300	400	296
CR 45-4	30	909	1520	415	300	400	296
CR 45-5-2	30	989	1600	415	300	400	301
CR 45-5-1	30	989	1600	415	300	400	301
CR 45-5	30	989	1600	415	300	400	301
CR 45-6-2	37	1069	1705	415	300	400	326
CR 45-6-1	37	1069	1705	415	300	400	326
CR 45-6	37	1069	1705	415	300	400	326
CR 45-7-2	45	1149	1857	442	325	450	405
CR 45-7-1	45	1149	1857	442	325	450	405
CR 45-7	45	1149	1857	442	325	450	405

CR 45 low-NPSH pumps are also available as CRN pumps with PJE connection.

CR 64 low-NPSH pumps, 60 Hz

Pump type	Motor P2 [kW]	CR					Net weight [kg]
		Dimension [mm]				DIN flange	
		DIN flange		D1	D2		
B1	B1 + B2						
CR 64-2-1	18.5	754	1269	314	204	350	205
CR 64-2	22	754	1295	314	204	350	221
CR 64-3-2	22	836	1377	314	204	350	232

Pump type	Motor P2 [kW]	CR					
		Dimension [mm]					Net weight [kg]
		DIN flange		D1	D2	D3	DIN flange
		B1	B1 + B2				
CR 64-3-1	30	836	1447	415	300	400	301
CR 64-3	30	836	1447	415	300	400	301
CR 64-4-2	37	919	1555	415	300	400	331
CR 64-4-1	37	919	1555	415	300	400	331
CR 64-4	45	919	1627	442	325	450	395
CR 64-5-2	45	1001	1709	442	325	450	400

CR 64 low-NPSH pumps are also available as CRN pumps with PJE connection.

CR pumps with 4-pole motor

Dimensions and weights

CR 1 with 4-pole motor, 50 Hz

Pump type	Motor P2 [kW]	CR								
		Dimension [mm]						Net weight [kg]		
		DIN flange		Oval flange		D1	D2	D3	DIN flange	Oval flange
		B1	B1 + B2	B1	B1 + B2					
CR 1-2	0.25	279	470	254	445	141	109	160	22	17
CR 1-3	0.25	279	470	254	445	141	109	160	22	17
CR 1-4	0.25	297	488	272	463	141	109	160	22	18
CR 1-5	0.25	315	506	290	481	141	109	160	23	18
CR 1-6	0.25	333	524	308	499	141	109	160	23	19
CR 1-7	0.25	351	542	326	517	141	109	160	24	19
CR 1-8	0.25	369	560	344	535	141	109	160	25	20
CR 1-9	0.25	387	578	362	553	141	109	160	25	20
CR 1-10	0.25	405	596	380	571	141	109	160	25	21
CR 1-11	0.25	423	614	398	589	141	109	160	26	21
CR 1-12	0.25	447	638	422	613	141	109	160	28	23
CR 1-13	0.25	465	656	440	631	141	109	160	28	24
CR 1-15	0.25	501	692	476	667	141	109	160	29	25
CR 1-17	0.25	537	728	512	703	141	109	160	32	28
CR 1-19	0.25	573	764	548	739	141	109	160	33	28
CR 1-21	0.25	609	800	584	775	141	109	160	34	29
CR 1-23	0.25	645	836	620	811	141	109	160	35	30
CR 1-25	0.25	697	888	-	-	141	109	160	43	-
CR 1-27	0.25	733	924	-	-	141	109	160	43	-
CR 1-30	0.25	787	978	-	-	141	109	160	45	-
CR 1-33	0.25	841	1032	-	-	141	109	160	46	-
CR 1-36	0.25	895	1086	-	-	141	109	160	48	-

4-pole CR 1 pumps are also available as CRI and CRN pumps with PJE and CA connection.

CR 3 with 4-pole motor, 50 Hz

Pump type	Motor P2 [kW]	CR								
		Dimension [mm]						Net weight [kg]		
		DIN flange		Oval flange		D1	D2	D3	DIN flange	Oval flange
		B1	B1 + B2	B1	B1 + B2					
CR 3-2	0.25	279	470	254	445	141	109	160	22	17
CR 3-3	0.25	279	470	254	445	141	109	160	22	17
CR 3-4	0.25	297	488	272	463	141	109	160	22	18
CR 3-5	0.25	315	506	290	481	141	109	160	23	18
CR 3-6	0.25	333	524	308	499	141	109	160	24	19
CR 3-7	0.25	351	542	326	517	141	109	160	24	20
CR 3-8	0.25	375	566	350	541	141	109	160	26	22
CR 3-9	0.25	393	584	368	559	141	109	160	27	22
CR 3-10	0.25	411	602	386	577	141	109	160	27	23
CR 3-11	0.25	429	620	404	595	141	109	160	30	25
CR 3-12	0.25	447	638	422	613	141	109	160	30	25
CR 3-13	0.25	465	656	440	631	141	109	160	30	26
CR 3-15	0.25	501	692	476	667	141	109	160	31	27
CR 3-17	0.25	553	744	528	719	141	109	160	39	35
CR 3-19	0.25	589	780	564	755	141	109	160	40	36
CR 3-21	0.25	625	816	600	791	141	109	160	41	37
CR 3-23	0.25	661	852	636	827	141	109	160	42	38
CR 3-25	0.25	697	888	-	-	141	109	160	43	-
CR 3-27	0.25	733	924	-	-	141	109	160	44	-
CR 3-29	0.37	769	960	-	-	141	109	160	46	-
CR 3-31	0.37	809	1000	-	-	141	109	160	51	-
CR 3-33	0.37	845	1036	-	-	141	109	160	51	-
CR 3-36	0.37	899	1090	-	-	141	109	160	53	-

4-pole CR 3 pumps are also available as CRI and CRN pumps with PJE and CA connection.

CR 5 with 4-pole motor, 50 Hz

Pump type	Motor P2 [kW]	CR								
		Dimension [mm]						Net weight [kg]		
		DIN flange		Oval flange		D1	D2	D3	DIN flange	Oval flange
		B1	B1 + B2	B1	B1 + B2					
CR 5-2	0.25	279	470	254	445	141	109	160	22	17
CR 5-3	0.25	306	497	281	472	141	109	160	23	19
CR 5-4	0.25	333	524	308	499	141	109	160	24	19
CR 5-5	0.25	366	557	341	532	141	109	160	26	21
CR 5-6	0.25	393	584	368	559	141	109	160	29	24
CR 5-7	0.25	420	611	395	586	141	109	160	29	25
CR 5-8	0.25	447	638	422	613	141	109	160	30	25
CR 5-9	0.25	490	681	465	656	141	109	160	37	33
CR 5-10	0.25	517	708	492	683	141	109	160	38	33
CR 5-11	0.25	544	735	519	710	141	109	160	39	35
CR 5-12	0.25	571	762	546	737	141	109	160	40	35
CR 5-13	0.25	598	789	573	764	141	109	160	40	36
CR 5-14	0.25	625	816	600	791	141	109	160	41	36
CR 5-15	0.25	652	843	627	818	141	109	160	42	37
CR 5-16	0.37	679	870	654	845	141	109	160	43	38
CR 5-18	0.37	737	928	712	903	141	109	160	48	44
CR 5-20	0.37	791	982	766	957	141	109	160	50	45
CR 5-22	0.37	845	1036	820	1011	141	109	160	62	56
CR 5-24	0.55	899	1130	-	-	141	109	200	62	-
CR 5-26	0.55	953	1184	-	-	141	109	200	63	-

Pump type	Motor P2 [kW]	CR								
		Dimension [mm]				Net weight [kg]				
		DIN flange		Oval flange		D1	D2	D3	DIN flange	Oval flange
		B1	B1 + B2	B1	B1 + B2					
CR 5-29	0.55	1034	1265	-	-	141	109	200	65	-
CR 5-32	0.55	1145	1376	-	-	141	109	200	81	-
CR 5-36	0.75	1253	1534	-	-	178	109	200	83	-

4-pole CR 5 pumps are also available as CRI and CRN pumps with PJE and CA connection.

CR 10 with 4-pole motor, 50 Hz

Pump type	Motor P2 [kW]	CR								
		Dimension [mm]				Net weight [kg]				
		DIN flange		Oval flange		D1	D2	D3	DIN flange	Oval flange
		B1	B1 + B2	B1	B1 + B2					
CR 10-1	0.25	343	534	343	534	141	109	160	33	30
CR 10-2	0.25	347	538	347	538	141	109	160	35	33
CR 10-3	0.25	377	568	377	568	141	109	160	38	36
CR 10-4	0.25	423	614	423	614	141	109	160	46	44
CR 10-5	0.25	453	644	453	644	141	109	160	48	45
CR 10-6	0.25	483	674	483	674	141	109	160	49	46
CR 10-7	0.37	518	709	518	709	141	109	160	55	52
CR 10-8	0.37	548	739	548	739	141	109	160	56	53
CR 10-9	0.37	578	769	578	769	141	109	160	57	54
CR 10-10	0.55	608	839	608	839	141	109	200	68	65
CR 10-12	0.6	668	899	668	899	141	109	200	70	68
CR 10-14	0.75	760	1041	760	1041	178	109	200	93	90
CR 10-16	0.75	820	1101	820	1101	178	109	200	95	92
CR 10-18	0.75	880	1161	-	-	178	109	200	100	-
CR 10-20	1.1	940	1261	-	-	178	110	200	98	-
CR 10-22	1.1	1000	1321	-	-	178	110	200	100	-

4-pole CR 10 pumps are also available as CRI and CRN pumps with PJE and CA connection.

CR 15 with 4-pole motor, 50 Hz

Pump type	Motor P2 [kW]	CR								
		Dimension [mm]				Net weight [kg]				
		DIN flange		Oval flange		D1	D2	D3	DIN flange	Oval flange
		B1	B1 + B2	B1	B1 + B2					
CR 15-1	0.25	400	591	400	591	141	109	160	41	40
CR 15-2	0.25	415	606	415	606	141	109	160	49	48
CR 15-3	0.37	465	656	465	656	141	109	160	55	54
CR 15-4	0.55	510	741	510	741	141	109	200	67	66
CR 15-5	0.55	555	786	555	786	141	109	200	68	67
CR 15-6	0.75	632	913	632	913	178	109	200	90	89
CR 15-7	0.75	677	958	677	958	178	109	200	92	91
CR 15-8	1.1	722	1043	-	-	178	110	200	92	-
CR 15-9	1.1	767	1088	-	-	178	110	200	93	-
CR 15-10	1.1	889	1210	-	-	178	110	200	125	-
CR 15-12	1.5	979	1260	-	-	178	110	200	134	-
CR 15-14	1.5	1069	1350	-	-	178	110	200	138	-
CR 15-17	2.2	1204	1525	-	-	198	120	250	157	-

4-pole CR 15 pumps are also available as CRI and CRN pumps with PJE and CA connection.

CR 20 with 4-pole motor, 50 Hz

Pump type	Motor P2 [kW]	CR								
		Dimension [mm]						Net weight [kg]		
		DIN flange		Oval flange		D1	D2	D3	DIN flange	Oval flange
		B1	B1 + B2	B1	B1 + B2					
CR 20-1	0.25	400	591	400	591	141	109	160	41	40
CR 20-2	0.37	415	606	415	606	141	109	160	50	49
CR 20-3	0.55	465	696	465	696	141	109	200	65	64
CR 20-4	0.6	542	773	542	773	141	109	200	87	86
CR 20-5	0.75	587	868	587	868	178	109	200	89	88
CR 20-6	1.1	632	953	632	953	178	110	200	88	-
CR 20-7	1.1	677	998	677	998	178	110	200	90	-
CR 20-8	1.1	799	1120	-	-	178	110	200	122	-
CR 20-10	1.5	889	1170	-	-	178	110	200	130	-
CR 20-12	2.2	979	1300	-	-	198	120	250	148	-
CR 20-14	2.2	1069	1390	-	-	198	120	250	152	-
CR 20-17	2.2	1204	1525	-	-	198	120	250	187	-

4-pole CR 20 pumps are also available as CRI and CRN pumps with PJE and CA connection.

CR 32 with 4-pole motor, 50 Hz

Pump type	Motor P2 [kW]	CR						
		Dimension [mm]					Net weight [kg]	
		DIN flange		D1	D2	D3	DIN flange	
		B1	B1 + B2					
CR 32-1-1	1.5	505	786	178	110	200	61	
CR 32-1	1.5	505	786	178	110	200	62	
CR 32-2-2	1.5	575	856	178	110	200	76	
CR 32-2	1.5	575	856	178	110	200	87	
CR 32-3-2	1.5	645	926	178	110	200	107	
CR 32-3	1.5	645	926	178	110	200	107	
CR 32-4-2	1.5	715	996	178	110	200	117	
CR 32-4	1.5	715	996	178	110	200	117	
CR 32-5-2	1.5	895	1176	178	110	200	155	
CR 32-5	1.5	895	1176	178	110	200	155	
CR 32-6-2	1.5	965	1246	178	110	200	158	
CR 32-6	1.5	965	1246	178	110	200	158	
CR 32-7-2	1.5	1035	1316	178	110	200	175	
CR 32-7	1.5	1035	1316	178	110	200	175	
CR 32-8-2	2.2	1105	1426	198	120	250	178	
CR 32-8	2.2	1105	1426	198	120	250	178	
CR 32-9-2	2.2	1175	1496	198	120	250	211	
CR 32-9	2.2	1175	1496	198	120	250	211	
CR 32-10-2	2.2	1245	1566	198	120	250	214	
CR 32-10	2.2	1245	1566	198	120	250	214	
CR 32-11-2	2.2	1315	1636	198	120	250	250	
CR 32-11	3	1315	1650	198	120	250	249	
CR 32-12-2	3	1385	1720	198	120	250	253	
CR 32-12	3	1385	1720	198	120	250	253	
CR 32-13-2	3	1455	1790	198	120	250	321	
CR 32-13	3	1455	1790	198	120	250	321	
CR 32-14-2	3	1525	1860	198	120	250	324	
CR 32-14	3	1525	1860	198	120	250	324	

4-pole CR 32 pumps are also available as CRN pumps with PJE connection.

CR 45 with 4-pole motor, 50 Hz

Pump type	Motor P2 [kW]	CR						
		Dimension [mm]					Net weight [kg]	
		DIN flange		D1	D2	D3		DIN flange
		B1	B1 + B2					
CR 45-1-1	1.5	559	840	178	110	200	80	
CR 45-1	1.5	559	840	178	110	200	91	
CR 45-2-2	1.5	639	920	178	110	200	108	
CR 45-2	1.5	639	920	178	110	200	110	
CR 45-3-2	1.5	829	1110	178	110	200	149	
CR 45-3	1.5	829	1110	178	110	200	149	
CR 45-4-2	1.5	909	1190	178	110	200	169	
CR 45-4	2.2	909	1230	198	120	250	169	
CR 45-5-2	2.2	989	1310	198	120	250	204	
CR 45-5	2.2	989	1310	198	120	250	204	
CR 45-6-2	3	1069	1404	198	120	250	239	
CR 45-6	3	1069	1404	198	120	250	239	
CR 45-7-2	3	1149	1484	198	120	250	320	
CR 45-7	3	1149	1484	198	120	250	320	
CR 45-8-2	4	1229	1601	220	134	250	336	
CR 45-8	4	1229	1601	220	134	250	336	
CR 45-9-2	4	1309	1681	220	134	250	341	
CR 45-9	4	1309	1681	220	134	250	361	
CR 45-10-2	4	1389	1761	220	134	250	366	
CR 45-10	4	1389	1761	220	134	250	366	
CR 45-11-2	5.5	1469	1860	260	159	300	487	
CR 45-11	5.5	1469	1860	260	159	300	487	
CR 45-12-2	5.5	1549	1940	260	159	300	492	
CR 45-12	5.5	1549	1940	260	159	300	492	
CR 45-13-2	5.5	1629	2020	260	159	300	497	

4-pole CR 45 pumps are also available as CRN pumps with PJE connection.

CR 64 with 4-pole motor, 50 Hz

Pump type	Motor P2 [kW]	CR					
		Dimension [mm]					Net weight [kg]
		DIN flange		D1	D2	D3	DIN flange
B1	B1 + B2						
CR 64-1-1	1.5	561	842	178	110	200	91
CR 64-1	1.5	561	842	178	110	200	102
CR 64-2-2	1.5	644	925	178	110	200	114
CR 64-2-1	1.5	754	1035	178	110	200	149
CR 64-2	1.5	754	1035	178	110	200	149
CR 64-3-2	2.2	836	1157	198	120	250	174
CR 64-3-1	2.2	836	1157	198	120	250	174
CR 64-3	2.2	836	1157	198	120	250	204
CR 64-4-2	3	919	1254	198	120	250	213
CR 64-4-1	3	919	1254	198	120	250	244
CR 64-4	3	919	1254	198	120	250	244
CR 64-5-2	3	1001	1336	198	120	250	315
CR 64-5-1	4	1001	1373	220	134	250	316
CR 64-5	4	1001	1373	220	134	250	316
CR 64-6-2	4	1084	1456	220	134	250	336
CR 64-6-1	4	1084	1456	220	134	250	356
CR 64-6	4	1084	1456	220	134	250	356
CR 64-7-2	5.5	1166	1557	260	159	300	385
CR 64-7-1	5.5	1166	1557	260	159	300	385
CR 64-7	5.5	1166	1557	260	159	300	449
CR 64-8-2	5.5	1249	1640	260	159	300	482

CR 95 with 4-pole motor, 50 Hz

Pump type	Motor P2 [kW]	CR						
		Dimension [mm]						Net weight [kg]
		DIN flange		D1	D2	D3	D4	DIN flange
B1	B1 + B2							
CR 95-1	5.5	689	1068	260	159	300	-	151
CR 95-2	5.5	793	1172	260	159	300	-	157
CR 95-3	5.5	898	1277	260	159	300	-	163
CR 95-4	5.5	1002	1381	260	159	300	-	169
CR 95-5	5.5	1107	1486	260	159	300	-	175
CR 95-6	5.5	1211	1590	260	159	300	-	181
CR 95-7	7.5	1316	1745	260	159	300	-	203
CR 95-8	11	1422	1948	318	204	350	-	251
CR 95-9	11	1527	2053	318	204	350	-	257
CR 95-10	11	1631	2157	318	204	350	-	262
CR 95-11	11	1736	2262	318	204	350	-	268
CR 95-12	15	1840	2392	318	204	350	-	296

CR 125 with 4-pole motor, 50 Hz

Pump type	Motor P2 [kW]	CR						Net weight [kg]
		Dimension [mm]						
		DIN flange		D1	D2	D3	D4	
B1	B1 + B2							
CR 125-1	11	783	1309	318	204	350	-	254
CR 125-2	11	905	1431	318	204	350	-	264
CR 125-3	11	1027	1553	318	204	350	-	275
CR 125-4	11	1149	1675	318	204	350	-	285
CR 125-5	11	1271	1797	318	204	350	-	295
CR 125-6	11	1393	1919	318	204	350	-	305
CR 125-7	11	1515	2041	318	204	350	-	316
CR 125-8	11	1637	2163	318	204	350	-	326
CR 125-9	15	1759	2311	318	204	350	-	358
CR 125-10	15	1881	2433	318	204	350	-	368
CR 125-11	15	2003	2555	318	204	350	-	379
CR 125-12	18.5	2125	2683	368	286	350	442	259

CR 155 with 4-pole motor, 50 Hz

Pump type	Motor P2 [kW]	CR						Net weight [kg]
		Dimension [mm]						
		DIN flange		D1	D2	D3	D4	
B1	B1 + B2							
CR 155-1	11	783	1309	318	204	350	-	255
CR 155-2	11	905	1431	318	204	350	-	265
CR 155-3	11	1027	1553	318	204	350	-	276
CR 155-4	11	1149	1675	318	204	350	-	287
CR 155-5	11	1271	1797	318	204	350	-	298
CR 155-6	11	1393	1919	318	204	350	-	308
CR 155-7	15	1515	2067	318	204	350	-	341
CR 155-8	15	1637	2189	318	204	350	-	352
CR 155-9	18.5	1759	2317	368	286	350	442	232
CR 155-10	18.5	1881	2439	368	286	350	442	243
CR 155-11	22	2003	2591	368	286	350	442	254
CR 155-12	22	2125	2713	368	286	350	442	265

CR 185 with 4-pole motor, 50 Hz

Pump type	Motor P2 [kW]	CR						Net weight [kg]
		Dimension [mm]						
		DIN flange		D1	D2	D3	D4	
B1	B1 + B2							
CR 185-1	11	854	1380	318	204	350	-	341
CR 185-2	11	982	1508	318	204	350	-	356
CR 185-3	11	1110	1636	318	204	350	-	371
CR 185-4	11	1238	1764	318	204	350	-	385
CR 185-5	15	1366	1918	318	204	350	-	422
CR 185-6	18.5	1494	2052	368	286	350	442	308
CR 185-7	18.5	1622	2180	368	286	350	442	323
CR 185-8	22	1750	2338	368	286	350	442	337
CR 185-9	30	1882	2518	408	315	400	492	354

CR 215 with 4-pole motor, 50 Hz

Pump type	Motor P2 [kW]	CR						Net weight [kg]
		Dimension [mm]				D3	D4	
		DIN flange		D1	D2			
B1	B1 + B2							
CR 215-1	11	854	1380	318	204	350	-	342
CR 215-2	11	982	1508	318	204	350	-	358
CR 215-3	11	1110	1636	318	204	350	-	373
CR 215-4	15	1238	1790	318	204	350	-	410
CR 215-5	18.5	1366	1924	368	286	350	442	461
CR 215-6	22	1494	2082	368	286	350	442	491
CR 215-7	30	1626	2262	408	315	400	492	569
CR 215-8	30	1754	2390	408	315	400	492	585
CR 215-9	37	1902	2612	449	338	450	573	675

CR 255 with 4-pole motor, 50 Hz

Pump type	Motor P2 [kW]	CR						Net weight [kg]
		Dimension [mm]				D3	D4	
		DIN flange		D1	D2			
B1	B1 + B2							
CR 255-1	11	854	1380	318	204	350	-	342
CR 255-2	11	982	1508	318	204	350	-	358
CR 255-3	15	1110	1662	318	204	350	-	395
CR 255-4	18.5	1238	1796	368	286	350	442	446
CR 255-5	22	1366	1954	368	286	350	442	476
CR 255-6	30	1498	2134	408	315	400	492	554
CR 255-7	30	1626	2262	408	315	400	492	569
CR 255-8	37	1774	2484	449	338	450	573	660
CR 255-9	45	1902	2649	449	338	450	573	710

CR 1 with 4-pole motor, 60 Hz

Pump type	Motor P2 [kW]	CR								
		Dimension [mm]						Net weight [kg]		
		DIN flange		Oval flange		D1	D2	D3	DIN flange	Oval flange
		B1	B1 + B2	B1	B1 + B2					
CR 1-2	0.25	279	470	254	445	141	109	105	22	17
CR 1-3	0.25	279	470	254	445	141	109	105	22	17
CR 1-4	0.25	297	488	272	463	141	109	105	22	18
CR 1-5	0.25	315	506	290	481	141	109	105	23	19
CR 1-6	0.25	333	524	308	499	141	109	105	24	19
CR 1-7	0.25	357	548	332	523	141	109	105	26	21
CR 1-8	0.25	375	566	350	541	141	109	105	26	22
CR 1-9	0.25	393	584	368	559	141	109	105	27	22
CR 1-10	0.25	411	602	386	577	141	109	105	29	25
CR 1-11	0.25	429	620	404	595	141	109	105	30	25
CR 1-12	0.25	447	638	422	613	141	109	105	30	25
CR 1-13	0.25	465	656	440	631	141	109	105	30	26
CR 1-15	0.25	517	708	492	683	141	109	105	38	34
CR 1-17	0.25	553	744	528	719	141	109	105	39	35
CR 1-19	0.25	589	780	-	-	141	109	105	41	-
CR 1-21	0.25	625	816	-	-	141	109	105	41	-
CR 1-23	0.25	661	852	-	-	141	109	105	42	-
CR 1-25	0.25	697	888	-	-	141	109	105	43	-
CR 1-27	0.37	737	928	-	-	141	109	105	49	-

4-pole CR 1 pumps are also available as CRI and CRN pumps with PJE and CA connection.

CR 3 with 4-pole motor, 60 Hz

Pump type	Motor P2 [kW]	CR								
		Dimension [mm]						Net weight [kg]		
		DIN flange		Oval flange		D1	D2	D3	DIN flange	Oval flange
		B1	B1 + B2	B1	B1 + B2					
CR 3-2	0.25	279	470	254	445	141	109	105	22	17
CR 3-3	0.25	279	470	254	445	141	109	105	23	18
CR 3-4	0.25	297	488	272	463	141	109	105	23	18
CR 3-5	0.25	321	512	296	487	141	109	105	25	21
CR 3-6	0.25	339	530	314	505	141	109	105	28	23
CR 3-7	0.25	357	548	332	523	141	109	105	28	23
CR 3-8	0.25	375	566	350	541	141	109	105	28	24
CR 3-9	0.25	409	600	384	575	141	109	105	36	31
CR 3-10	0.25	427	618	402	593	141	109	105	36	32
CR 3-11	0.25	445	636	420	611	141	109	105	37	32
CR 3-12	0.25	463	654	438	629	141	109	105	38	33
CR 3-13	0.25	481	672	456	647	141	109	105	38	33
CR 3-15	0.25	517	708	492	683	141	109	105	39	34
CR 3-17	0.37	553	744	528	719	141	109	105	41	36
CR 3-19	0.37	593	784	-	-	141	109	105	46	-
CR 3-21	0.37	629	820	-	-	141	109	105	47	-
CR 3-23	0.37	665	856	-	-	141	109	105	47	-
CR 3-25	0.55	701	932	-	-	141	109	120	58	-

4-pole CR 3 pumps are also available as CRI and CRN pumps with PJE and CA connection.

CR 5 with 4-pole motor, 60 Hz

Pump type	Motor P2 [kW]	CR								
		Dimension [mm]						Net weight [kg]		
		DIN flange		Oval flange		D1	D2	D3	DIN flange	Oval flange
		B1	B1 + B2	B1	B1 + B2					
CR 5-2	0.25	279	470	254	445	141	109	105	22	18
CR 5-3	0.25	312	503	287	478	141	109	105	27	22
CR 5-4	0.25	339	530	314	505	141	109	105	27	23
CR 5-5	0.25	382	573	357	548	141	109	105	35	31
CR 5-6	0.25	409	600	384	575	141	109	105	36	32
CR 5-7	0.25	436	627	411	602	141	109	105	37	32
CR 5-8	0.25	463	654	438	629	141	109	105	37	33
CR 5-9	0.25	490	681	465	656	141	109	105	38	33
CR 5-10	0.37	521	712	496	687	141	109	105	44	39
CR 5-11	0.37	548	739	523	714	141	109	105	44	40
CR 5-12	0.37	575	766	550	741	141	109	105	45	40
CR 5-13	0.37	602	793	577	768	141	109	105	56	52
CR 5-14	0.55	629	860	604	835	141	109	120	56	52
CR 5-15	0.55	656	887	631	862	141	109	120	57	52
CR 5-16	0.55	683	914	658	889	141	109	120	57	53
CR 5-18	0.55	767	998	-	-	141	109	120	73	-
CR 5-20	0.75	821	1052	-	-	141	109	120	74	-
CR 5-22	0.75	875	1106	-	-	141	109	120	75	-
CR 5-24	0.75	929	1160	-	-	141	109	120	78	-

4-pole CR 5 pumps are also available as CRI and CRN pumps with PJE and CA connection.

CR 10 with 4-pole motor, 60 Hz

Pump type	Motor P2 [kW]	CR								
		Dimension [mm]						Net weight [kg]		
		DIN flange		Oval flange		D1	D2	D3	DIN flange	Oval flange
		B1	B1 + B2	B1	B1 + B2					
CR 10-1	0.25	347	538	347	538	141	109	105	35	32
CR 10-2	0.25	363	554	363	554	141	109	105	44	42
CR 10-3	0.25	393	584	393	584	141	109	105	46	43
CR 10-4	0.37	428	619	428	619	141	109	105	52	49
CR 10-5	0.37	458	649	458	649	141	109	105	53	50
CR 10-6	0.55	488	719	488	719	141	109	120	64	61
CR 10-7	0.55	550	781	550	781	141	109	120	86	83
CR 10-8	0.75	580	811	580	811	141	109	120	87	84
CR 10-9	0.75	610	841	610	841	141	109	120	88	85
CR 10-10	0.75	640	871	640	871	141	109	120	91	88
CR 10-12	1.1	700	981	-	-	178	110	135	89	-
CR 10-14	1.1	837	1118	-	-	178	110	135	122	-
CR 10-16	1.5	897	1178	-	-	178	110	135	129	-
CR 10-17	1.5	957	1238	-	-	178	110	135	131	-

4-pole CR 10 pumps are also available as CRI and CRN pumps with PJE and CA connection.

CR 15 with 4-pole motor, 60 Hz

Pump type	Motor P2 [kW]	CR								
		Dimension [mm]						Net weight [kg]		
		DIN flange		Oval flange		D1	D2	D3	DIN flange	Oval flange
		B1	B1 + B2	B1	B1 + B2					
CR 15-1	0.25	415	606	415	606	141	109	105	48	47
CR 15-2	0.37	420	611	420	611	141	109	105	54	53
CR 15-3	0.55	465	696	465	696	141	109	120	65	64
CR 15-4	0.75	542	773	542	773	141	109	120	87	86

Pump type	Motor P2 [kW]	CR								
		Dimension [mm]				Net weight [kg]				
		DIN flange		Oval flange		D1	D2	D3	DIN flange	Oval flange
		B1	B1 + B2	B1	B1 + B2					
CR 15-5	1.1	587	868	587	868	178	110	135	87	86
CR 15-6	1.1	709	990	-	-	178	110	135	119	-
CR 15-7	1.5	754	1035	-	-	178	110	135	125	-
CR 15-8	1.5	799	1080	-	-	178	110	135	127	-
CR 15-9	2.2	844	1179	-	-	198	120	160	143	-
CR 15-10	2.2	889	1224	-	-	198	120	160	145	-
CR 15-12	2.2	979	1314	-	-	198	120	160	178	-

4-pole CR 15 pumps are also available as CRI and CRN pumps with PJE and CA connection.

CR 20 with 4-pole motor, 60 Hz

Pump type	Motor P2 [kW]	CR								
		Dimension [mm]				Net weight [kg]				
		DIN flange		Oval flange		D1	D2	D3	DIN flange	Oval flange
		B1	B1 + B2	B1	B1 + B2					
CR 20-1	0.25	415	606	415	606	141	109	105	49	48
CR 20-2	0.55	420	651	420	651	141	109	120	64	63
CR 20-3	0.75	497	728	497	728	141	109	120	86	85
CR 20-4	1.1	542	823	542	823	178	110	135	85	84
CR 20-5	1.5	664	945	664	945	178	110	135	122	121
CR 20-6	1.5	709	990	-	-	178	110	135	124	-
CR 20-7	2.2	754	1089	-	-	198	120	160	139	-
CR 20-8	2.2	799	1134	-	-	198	120	160	141	-
CR 20-10	3	889	1224	-	-	198	120	160	174	-

4-pole CR 20 pumps are also available as CRI and CRN pumps with PJE and CA connection.

CR 32 with 4-pole motor, 60 Hz

Pump type	Motor P2 [kW]	CR					
		Dimension [mm]			Net weight [kg]		
		DIN flange		D1	D2	D3	DIN flange
		B1	B1 + B2				
CR 32-1-1	1.5	505	786	178	110	135	62
CR 32-1	1.5	505	786	178	110	135	66
CR 32-2-2	1.5	575	856	178	110	135	98
CR 32-2-1	1.5	575	856	178	110	135	98
CR 32-2	1.5	575	856	178	110	135	100
CR 32-3-2	1.5	755	1036	178	110	135	144
CR 32-3	1.5	755	1036	178	110	135	144
CR 32-4-2	1.5	825	1106	178	110	135	152
CR 32-4	2.2	825	1160	198	120	160	166
CR 32-5-2	2.2	895	1230	198	120	160	169
CR 32-5	2.2	895	1230	198	120	160	199
CR 32-6-2	2.2	965	1300	198	120	160	202
CR 32-6	2.2	965	1300	198	120	160	202
CR 32-7-2	3	1035	1370	198	120	160	235
CR 32-7	3	1035	1370	198	120	160	235
CR 32-8-2	3	1105	1440	198	120	160	304
CR 32-8	3	1105	1440	198	120	160	304
CR 32-9-2	4	1175	1547	220	134	160	308
CR 32-9	4	1175	1547	220	134	160	308
CR 32-10-2	4	1245	1617	220	134	160	311

4-pole CR 32 pumps are also available as CRN pumps with PJE connection.

CR 45 with 4-pole motor, 60 Hz

Pump type	Motor P2 [kW]	CR					Net weight [kg]
		Dimension [mm]			DIN flange		
		B1	B1 + B2	D1	D2	D3	
CR 45-1-1	1.5	559	840	178	110	135	102
CR 45-1	1.5	559	840	178	110	135	104
CR 45-2-2	1.5	749	1030	178	110	135	145
CR 45-2-1	1.5	749	1030	178	110	135	145
CR 45-2	2.2	749	1084	198	120	160	159
CR 45-3-2	2.2	829	1164	198	120	160	193
CR 45-3-1	2.2	829	1164	198	120	160	193
CR 45-3	2.2	829	1164	198	120	160	193
CR 45-4-2	3	909	1244	198	120	160	229
CR 45-4-1	3	909	1244	198	120	160	295
CR 45-4	3	909	1244	198	120	160	295
CR 45-5-2	4	989	1361	220	134	160	301
CR 45-5-1	4	989	1361	220	134	160	301
CR 45-5	4	989	1361	220	134	160	301
CR 45-6-2	4	1069	1441	220	134	160	326
CR 45-6-1	5.5	1069	1448	260	159	300	335
CR 45-6	5.5	1069	1448	260	159	300	335
CR 45-7-2	5.5	1149	1528	260	159	300	414
CR 45-7-1	5.5	1149	1528	260	159	300	414
CR 45-7	5.5	1149	1528	260	159	300	414

4-pole CR 45 pumps are also available as CRN pumps with PJE connection.

CR 64 with 4-pole motor, 60 Hz

Pump type	Motor P2 [kW]	CR					Net weight [kg]
		Dimension [mm]			DIN flange		
		B1	B1 + B2	D1	D2	D3	
CR 64-1-1	1.5	561	842	178	110	135	104
CR 64-1	1.5	671	952	178	110	135	139
CR 64-2-2	2.2	754	1089	198	120	160	163
CR 64-2-1	2.2	754	1089	198	120	160	193
CR 64-2	3	754	1089	198	120	160	223
CR 64-3-2	3	836	1171	198	120	160	234
CR 64-3-1	4	836	1208	220	134	160	301
CR 64-3	4	836	1208	220	134	160	301
CR 64-4-2	4	919	1291	220	134	160	331
CR 64-4-1	5.5	919	1298	260	159	300	340
CR 64-4	5.5	919	1298	260	159	300	404
CR 64-5-2	5.5	1001	1380	260	159	300	409

4-pole CR 64 pumps are also available as CRN pumps with PJE connection.

CR 95 with 4-pole motor, 60 Hz

Pump type	Motor P2 [kW]	CR						Net weight [kg]
		Dimension [mm]				DIN flange		
		B1	B1 + B2	D1	D2	D3	D4	
CR 95-1	5.5	689	1068	260	159	300	-	151
CR 95-2	5.5	793	1172	260	159	300	-	157
CR 95-3	5.5	898	1277	260	159	300	-	163
CR 95-4	7.5	1002	1431	260	159	300	-	185
CR 95-5	11	1109	1635	318	204	350	-	233

Pump type	Motor P2 [kW]	CR						
		Dimension [mm]						Net weight [kg]
		DIN flange		D1	D2	D3	D4	DIN flange
B1	B1 + B2							
CR 95-6	11	1213	1739	318	204	350	-	239
CR 95-7	15	1318	1870	318	204	350	-	267
CR 95-8	15	1422	1974	318	204	350	-	273
CR 95-9	15	1527	2079	318	204	350	-	279
CR 95-10	18.5	1631	2189	368	286	350	442	156
CR 95-11	18.5	1736	2294	368	286	350	442	162
CR 95-12	22	1840	2428	368	286	350	442	168

CR 125 with 4-pole motor, 60 Hz

Pump type	Motor P2 [kW]	CR						
		Dimension [mm]						Net weight [kg]
		DIN flange		D1	D2	D3	D4	DIN flange
B1	B1 + B2							
CR 125-1	11	783	1309	318	204	350	-	254
CR 125-2	11	905	1431	318	204	350	-	264
CR 125-3	11	1027	1553	318	204	350	-	275
CR 125-4	11	1149	1675	318	204	350	-	285
CR 125-5	15	1271	1823	318	204	350	-	317
CR 125-6	15	1393	1945	318	204	350	-	327
CR 125-7	18.5	1515	2073	368	286	350	442	209
CR 125-8	18.5	1637	2195	368	286	350	442	219
CR 125-9	22	1759	2347	368	286	350	442	229
CR 125-10	30	1883	2519	408	315	400	492	243
CR 125-11	30	2005	2641	408	315	400	492	253
CR 125-12	30	2127	2763	408	315	400	492	264

CR 155 with 4-pole motor, 60 Hz

Pump type	Motor P2 [kW]	CR						
		Dimension [mm]						Net weight [kg]
		DIN flange		D1	D2	D3	D4	DIN flange
B1	B1 + B2							
CR 155-1	11	783	1309	318	204	350	-	255
CR 155-2	11	905	1431	318	204	350	-	265
CR 155-3	11	1027	1553	318	204	350	-	276
CR 155-4	15	1149	1701	318	204	350	-	309
CR 155-5	18.5	1271	1829	368	286	350	442	191
CR 155-6	18.5	1393	1951	368	286	350	442	201
CR 155-7	22	1515	2103	368	286	350	442	212
CR 155-8	30	1639	2275	408	315	400	492	227
CR 155-9	30	1761	2397	408	315	400	492	237
CR 155-10	37	1906	2616	449	338	450	573	263
CR 155-11	37	2028	2738	449	338	450	573	274
CR 155-12	37	2150	2860	449	338	450	573	284

CR 185 with 4-pole motor, 60 Hz

Pump type	Motor P2 [kW]	CR						
		Dimension [mm]						Net weight [kg]
		DIN flange		D1	D2	D3	D4	DIN flange
B1	B1 + B2							
CR 185-1	11	854	1380	318	204	350	-	341
CR 185-2	11	982	1508	318	204	350	-	356
CR 185-3	15	1110	1662	318	204	350	-	393

Pump type	Motor P2 [kW]	CR						Net weight [kg]
		Dimension [mm]						
		DIN flange		D1	D2	D3	D4	
B1	B1 + B2							
CR 185-4	18.5	1238	1796	368	286	350	442	279
CR 185-5	30	1370	2006	408	315	400	492	296
CR 185-6	30	1498	2134	408	315	400	492	311
CR 185-7	37	1626	2262	408	315	400	573	325
CR 185-8	37	1774	2484	449	338	450	573	355
CR 185-9	45	1902	2610	449	338	450	573	369

CR 215 with 4-pole motor, 60 Hz

Pump type	Motor P2 [kW]	CR						Net weight [kg]
		Dimension [mm]						
		DIN flange		D1	D2	D3	D4	
B1	B1 + B2							
CR 215-1	11	854	1380	318	204	350	-	342
CR 215-2	15	982	1534	318	204	350	-	380
CR 215-3	18.5	1110	1668	368	286	350	-	430
CR 215-4	30	1242	1878	408	315	400	442	523
CR 215-5	37	1390	2100	449	338	450	492	614
CR 215-6	45	1518	2226	449	338	450	573	664
CR 215-7	45	1646	2354	449	338	450	573	679
CR 215-8	55	1780	2527	497	410	550	732	825

CR 255 with 4-pole motor, 60 Hz

Pump type	Motor P2 [kW]	CR						Net weight [kg]
		Dimension [mm]						
		DIN flange		D1	D2	D3	D4	
B1	B1 + B2							
CR 255-1	11	854	1380	318	204	350	-	342
CR 255-2	18.5	982	1540	368	286	350	442	415
CR 255-3	30	1114	1750	408	315	400	492	508
CR 255-4	30	1242	1878	408	315	400	492	523
CR 255-5	45	1390	2098	449	338	450	573	649
CR 255-6	45	1518	2226	449	338	450	573	664
CR 255-7	55	1652	2399	497	410	550	732	810

CR deep-well pumps

Dimensional drawing

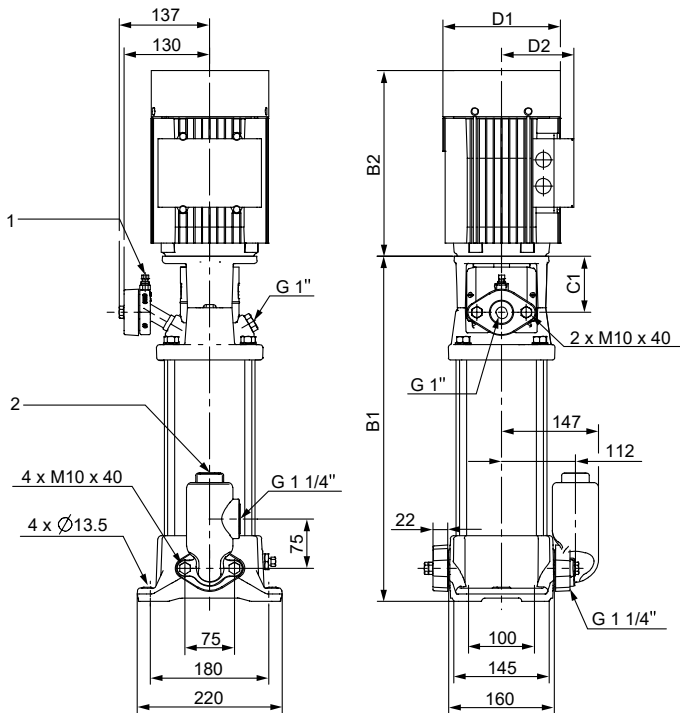

TM038261

CR 5

Pos.	Description
1	Vent screw G 1/8"
2	Priming plug G 1 1/2"

CR deep-well pumps, 50 Hz

Dimensions

Pump	Motor P2 [kW]	Dimensions [mm]				
		B1	B1 + B2	C1	D1	D2
CR, CRI 5-9	1.5	465	746	85	178	110
CR, CRI 5-11	2.2	519	840	85	178	110
CR, CRI 5-13	2.2	573	894	85	178	110
CR, CRI 5-15	2.2	627	948	85	178	110

Pump	Motor P2 [kW]	Suction depth [m]	Flow rate [m³/h]	Ejector No	Pressure class, plastic pipe [kp/cm²]	Pipe dimensions [mm]		Largest ejector diameter [mm]
						Ejector inlet: external/ internal	Ejector outlet: external/ internal	
CR, CRI 5-9	1.5	54	0.25	11	6 + 6	32/26	40/32.6	76
		42	0.68	29	6 + 6	32/26	40/32.6	76
		35	0.92	20	6 + 6	32/26	40/32.6	76
		27	1.25	22	6 + 6	32/26	40/32.6	76
CR, CRI 5-11	2.2	65	0.25	11	10 + 10	32/22.8	40/28.4	80
		50	0.62	29	10 + 6	32/22.8	40/32.6	76
		45	0.85	20	6 + 6	32/26	40/32.6	76
		40	1.10	22	6 + 6	32/26	40/32.6	76
		35	1.37	44	6 + 6	32/26	40/32.6	76
		28	1.75	45	6 + 6	32/26	40/32.6	76

Pump	Motor P2 [kW]	Suction depth [m]	Flow rate [m ³ /h]	Ejector No	Pressure class, plastic pipe [kp/cm ²]	Pipe dimensions [mm]		Largest ejector diameter [mm]
						Ejector inlet: external/internal	Ejector outlet: external/internal	
CR, CRI 5-13	2.2	79	0.25	11	10 + 10	32/22.8	40/28.4	80
		63	0.62	29	10 + 10	32/22.8	40/28.4	80
		54	0.87	20	10 + 6	32/22.8	40/32.6	76
		45	1.17	22	10 + 6	32/22.8	40/32.6	76
		40	1.39	44	6 + 6	32/26	40/32.6	76
		33	1.99	45	6 + 6	32/26	40/32.6	76
CR, CRI 5-15	2.2	93	0.25	11	10 + 10	32/22.8	40/28.4	80
		73	0.63	29	10 + 10	32/22.8	40/28.4	80
		62	0.88	20	10 + 10	32/22.8	40/28.4	80
		53	1.14	22	10 + 6	32/22.8	40/32.6	76
		46	1.40	44	10 + 6	32/22.8	40/32.6	76
		37	1.99	45	10 + 6	32/22.8	40/32.6	76

CR deep-well pumps, 60 Hz

Dimensions

Pump	Motor P2 [kW]	Dimensions [mm]				
		B1	B1 + B2	C1	D1	D2
CR, CRI 5-6	2.2	384	705	85	178	110
CR, CRI 5-8	2.2	438	759	85	178	110
CR, CRI 5-9	2.2	465	786	85	178	110

Pump	Motor P2 [kW]	Suction depth, [m]	Flow rate [m ³ /h]	Ejector No	Pressure class, plastic pipe [kp/cm ²]	Pipe dimensions [mm]		Largest ejector diameter [mm]
						Ejector inlet: external/internal	Ejector outlet: external/internal	
CR, CRI 5-6	2.2	52	0.33	11	6 + 6	32/26	40/32.6	76
		45	0.69	29	6 + 6	32/26	40/32.6	76
		41	0.91	20	6 + 6	32/26	40/32.6	76
		37	1.16	22	6 + 6	32/26	40/32.6	76
		34	1.35	44	6 + 6	32/26	40/32.6	76
		30	1.65	45	6 + 6	32/26	40/32.6	76
CR, CRI 5-8	2.2	65	0.38	11	10 + 10	32/22.8	40/28.4	80
		60	0.60	29	10 + 6	32/22.8	40/32.6	76
		53	0.94	20	6 + 6	32/26	40/32.6	76
		50	1.10	22	6 + 6	32/26	40/32.6	76
		45	1.37	44	6 + 6	32/26	40/32.6	76
CR, CRI 5-9	2.2	73	0.37	11	10 + 10	32/22.8	40/28.4	80
		65	0.68	29	10 + 10	32/22.8	40/28.4	80
		60	0.88	20	10 + 6	32/22.8	40/32.6	76
		55	1.11	22	10 + 6	32/22.8	40/32.6	76
		50	1.39	44	6 + 6	32/26	40/32.6	76
		47	1.63	45	6 + 6	32/26	40/32.6	76

CRN pumps with magnetic drive

Dimensional drawings for CRN pumps with magnetic drive

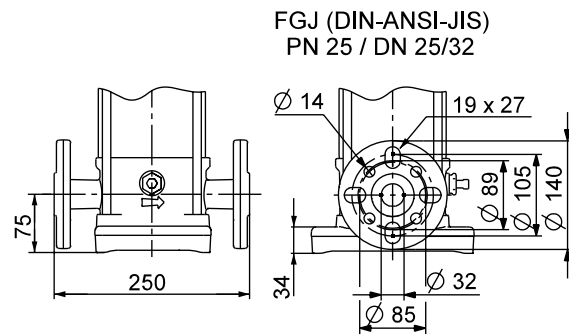
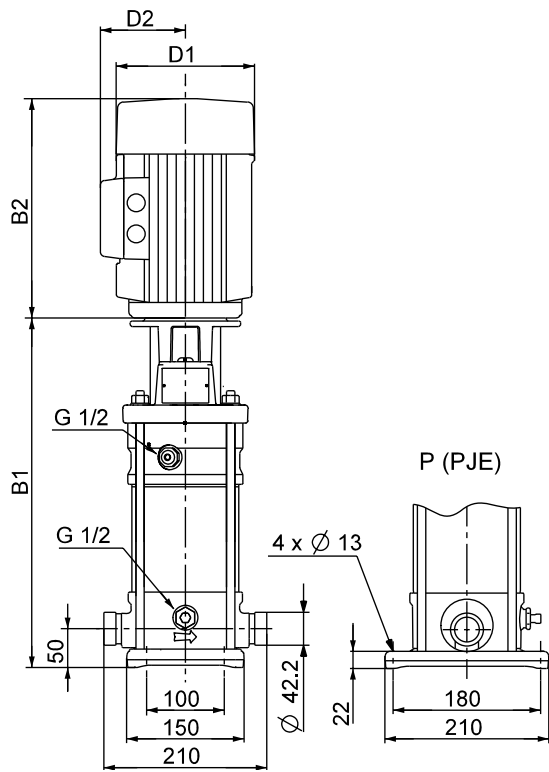

TMO39137

CRN 1, CRN 3

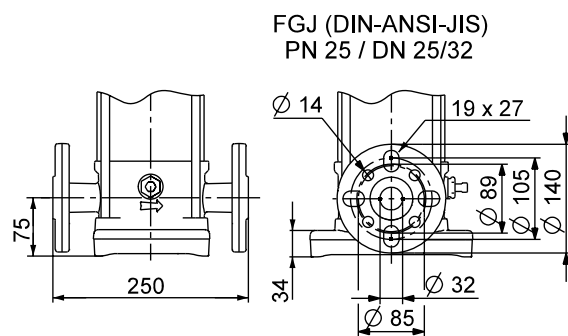
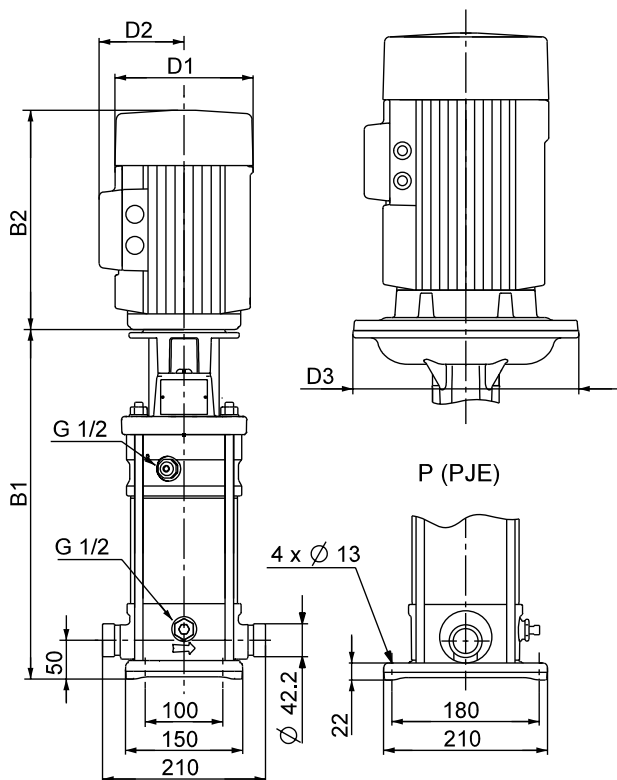

TMO39138

CRN 5

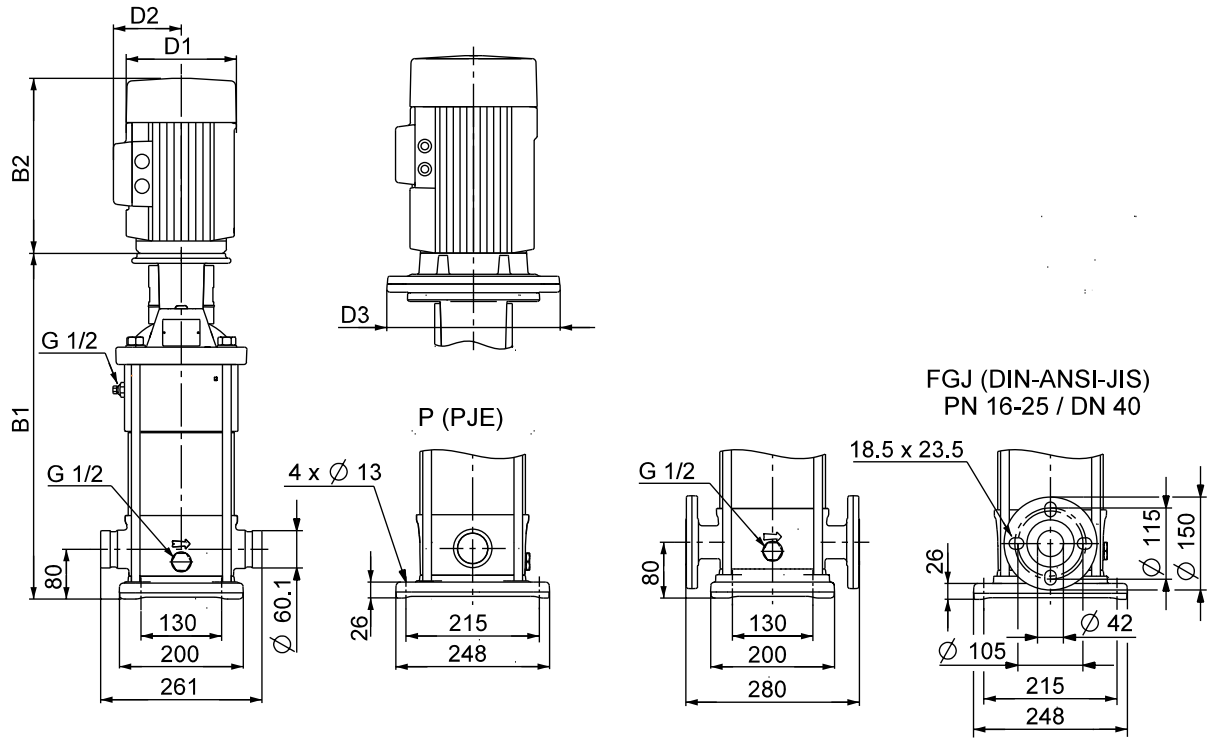

TM039140

CRN 10

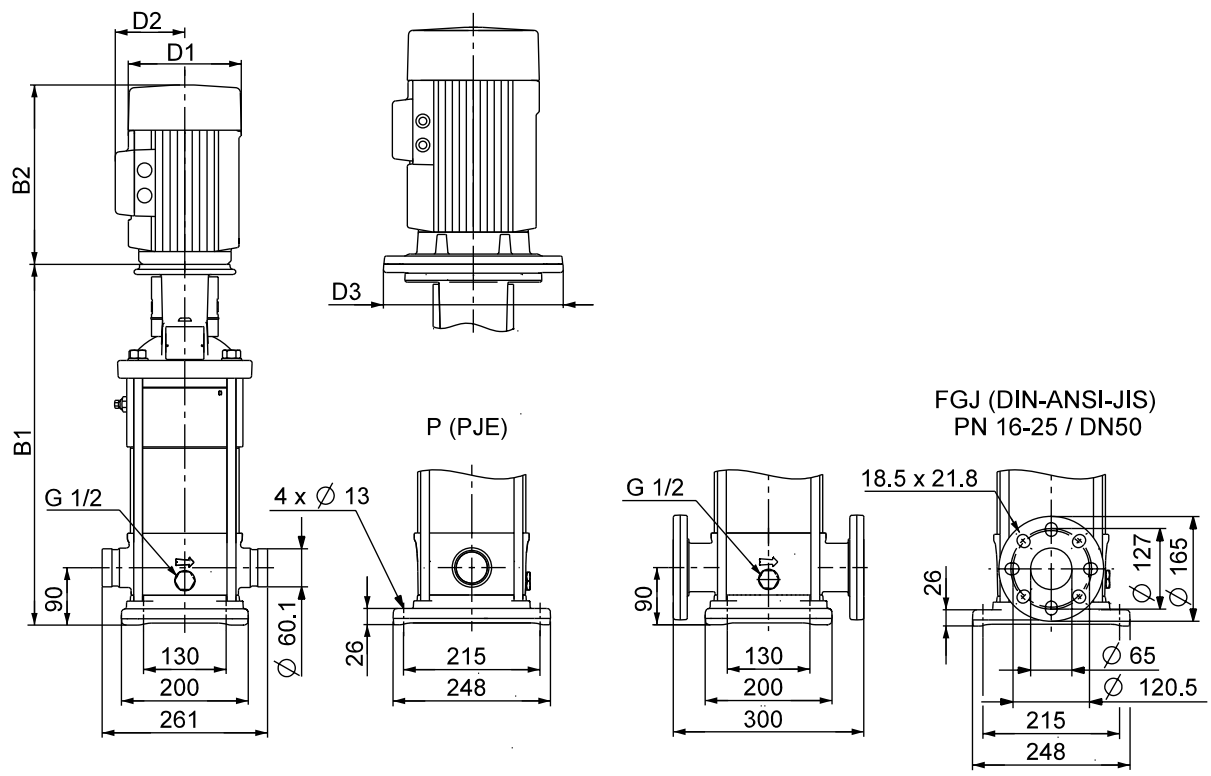

TM039139

CRN 15, CRN 20

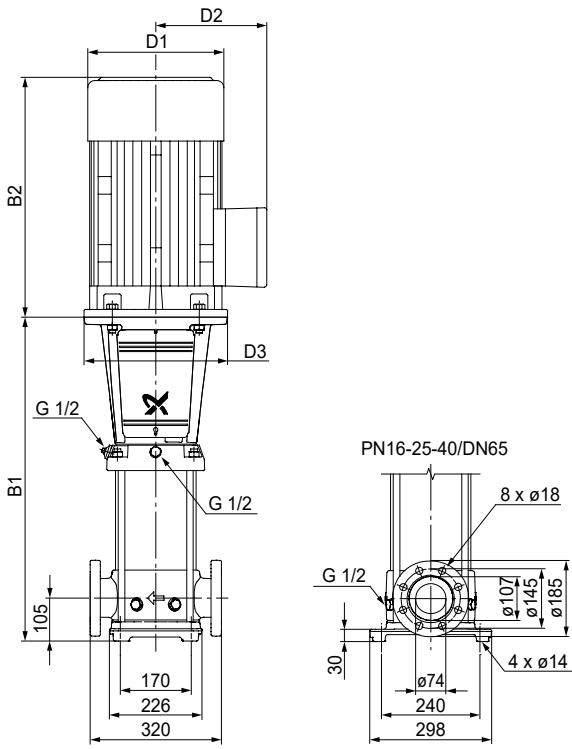

CRN 32

TM011750

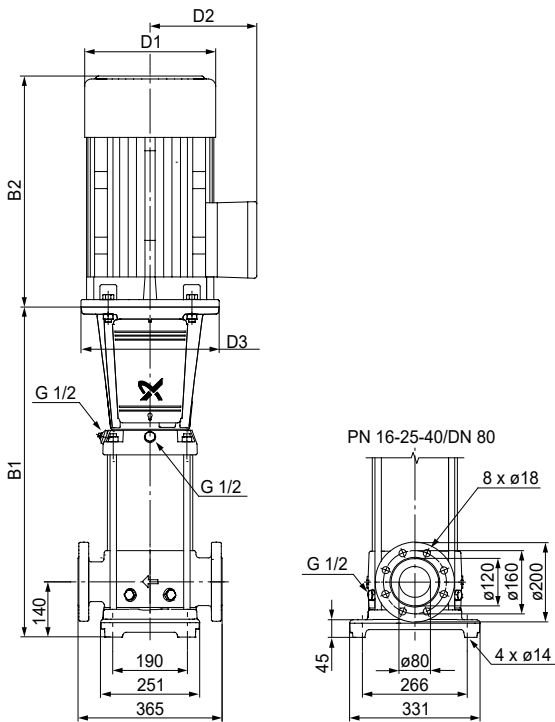

CRN 45

TM011752

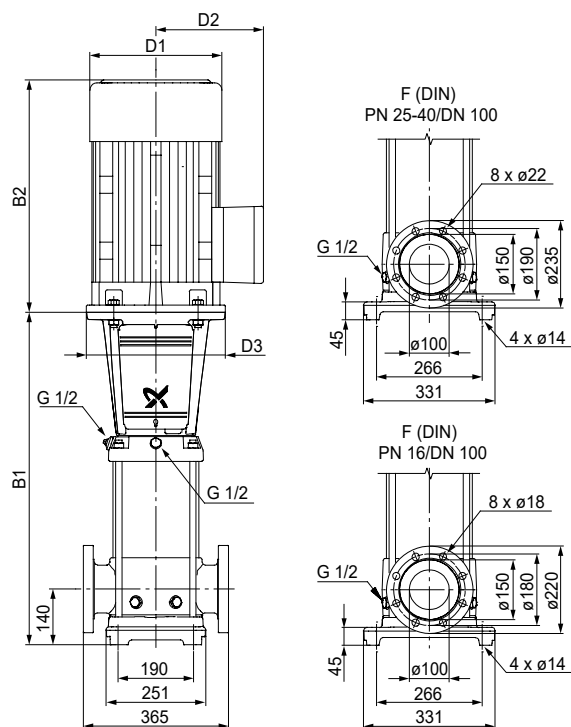

CRN 64

Dimensions and weights

CRN 1s - MAGdrive, 50 Hz

Pump type	Motor P2 [kW]	Dimension [mm]							Net weight [kg]	
		DIN flange		Oval flange		D1	D2	D3	DIN flange	Oval flange
		B1	B1 + B2	B1	B1 + B2					
CRN 1s-2	0.37	367	558	342	533	141	109	-	24	20
CRN 1s-3	0.37	367	558	342	533	141	109	-	25	20
CRN 1s-4	0.37	385	576	360	551	141	109	-	25	21
CRN 1s-5	0.37	403	594	378	569	141	109	-	25	21
CRN 1s-6	0.37	421	612	396	587	141	109	-	26	22
CRN 1s-7	0.37	439	630	414	605	141	109	-	26	22
CRN 1s-8	0.37	457	648	432	623	141	109	-	27	22
CRN 1s-9	0.37	475	666	450	641	141	109	-	27	23
CRN 1s-10	0.37	493	684	468	659	141	109	-	27	23
CRN 1s-11	0.55	511	702	486	677	141	109	-	29	24
CRN 1s-12	0.55	529	720	504	695	141	109	-	29	25
CRN 1s-13	0.55	547	738	522	713	141	109	-	30	25
CRN 1s-15	0.55	583	774	558	749	141	109	-	30	26
CRN 1s-17	0.55	619	810	594	785	141	109	-	31	27
CRN 1s-19	0.75	655	886	630	861	141	109	-	33	28
CRN 1s-21	0.75	697	928	672	903	141	109	-	35	30
CRN 1s-23	0.75	733	964	708	939	141	109	-	35	31
CRN 1s-25	1.1	769	1000	744	975	141	109	-	39	35
CRN 1s-27	1.1	805	1036	780	1011	141	109	-	39	35
CRN 1s-30	1.1	859	1090	834	1065	141	109	-	40	36
CRN 1s-33	1.1	913	1144	888	1119	141	109	-	41	37
CRN 1s-36	1.1	967	1198	942	1173	141	109	-	43	38

TM011754

CRN 1 - MAGdrive, 50 Hz

Pump type	Motor P2 [kW]	Dimension [mm]							Net weight [kg]	
		DIN flange		Oval flange		D1	D2	D3	DIN flange	Oval flange
		B1	B1 + B2	B1	B1 + B2					
CRN 1-2	0.37	367	558	342	533	141	109	-	24	20
CRN 1-3	0.37	367	558	342	533	141	109	-	25	20
CRN 1-4	0.37	385	576	360	551	141	109	-	25	21
CRN 1-5	0.37	403	594	378	569	141	109	-	25	21
CRN 1-6	0.37	421	612	396	587	141	109	-	26	22
CRN 1-7	0.55	439	630	414	605	141	109	-	26	22
CRN 1-8	0.55	457	648	432	623	141	109	-	27	22
CRN 1-9	0.55	475	666	450	641	141	109	-	27	23
CRN 1-10	0.55	493	684	468	659	141	109	-	27	23
CRN 1-11	0.75	511	702	486	677	141	109	-	29	24
CRN 1-12	0.75	535	720	504	695	141	109	-	29	25
CRN 1-13	0.75	553	738	522	713	141	109	-	30	25
CRN 1-15	0.75	589	774	558	749	141	109	-	30	26
CRN 1-17	1.1	625	810	594	785	141	109	-	31	27
CRN 1-19	1.1	661	886	630	861	141	109	-	33	28
CRN 1-21	1.1	697	928	672	903	141	109	-	35	30
CRN 1-23	1.1	733	964	708	939	141	109	-	35	31
CRN 1-25	1.5	785	1000	744	975	141	109	-	39	35
CRN 1-27	1.5	821	1036	780	1011	141	109	-	39	35
CRN 1-30	1.5	875	1090	834	1065	141	109	-	40	36
CRN 1-33	2.2	929	1144	888	1119	141	109	-	41	37
CRN 1-36	2.2	983	1198	942	1173	141	109	-	43	38

CRN 3 - MAGdrive, 50 Hz

Pump type	Motor P2 [kW]	Dimension [mm]							Net weight [kg]	
		DIN flange		Oval flange		D1	D2	D3	DIN flange	Oval flange
		B1	B1 + B2	B1	B1 + B2					
CRN 3-2	0.37	367	558	342	533	141	109	-	24	20
CRN 3-3	0.37	367	558	342	533	141	109	-	25	20
CRN 3-4	0.37	385	576	360	551	141	109	-	25	21
CRN 3-5	0.55	403	594	378	569	141	109	-	26	22
CRN 3-6	0.55	421	612	396	587	141	109	-	27	22
CRN 3-7	0.55	439	630	414	605	141	109	-	27	23
CRN 3-8	0.75	463	694	438	669	141	109	-	30	25
CRN 3-9	0.75	481	712	456	687	141	109	-	30	26
CRN 3-10	0.75	499	730	474	705	141	109	-	30	26
CRN 3-11	1.1	517	748	492	723	141	109	-	33	29
CRN 3-12	1.1	535	766	510	741	141	109	-	33	29
CRN 3-13	1.1	553	784	528	759	141	109	-	34	30
CRN 3-15	1.1	589	820	564	795	141	109	-	35	30
CRN 3-17	1.5	641	922	616	897	178	110	-	43	39
CRN 3-19	1.5	677	958	652	933	178	110	-	44	39
CRN 3-21	2.2	713	1034	688	1009	178	110	-	45	41
CRN 3-23	2.2	749	1070	724	1045	178	110	-	46	42
CRN 3-25	2.2	785	1106	760	1081	178	110	-	47	42
CRN 3-27	2.2	821	1142	796	1117	178	110	-	47	43
CRN 3-29	2.2	857	1178	832	1153	178	110	-	48	44
CRN 3-31	3	897	1232	872	1207	198	120	-	53	49
CRN 3-33	3	933	1268	908	1243	198	120	-	54	50
CRN 3-36	3	987	1322	962	1297	198	120	-	55	51

CRN 5 - MAGdrive, 50 Hz

Pump type	Motor P2 [kW]	Dimension [mm]							Net weight [kg]	
		DIN flange		Oval flange		D1	D2	D3	DIN flange	Oval flange
		B1	B1 + B2	B1	B1 + B2					
CRN 5-2	0.37	367	558	342	533	141	109	-	26	21
CRN 5-3	0.55	394	585	369	560	141	109	-	27	23
CRN 5-4	0.75	421	652	396	627	141	109	-	28	24
CRN 5-5	0.75	454	685	429	660	141	109	-	30	26
CRN 5-6	1.1	481	712	456	687	141	109	-	33	29
CRN 5-7	1.1	508	739	483	714	141	109	-	33	29
CRN 5-8	1.1	535	766	510	741	141	109	-	34	30
CRN 5-9	1.5	578	859	553	834	178	110	-	41	37
CRN 5-10	1.5	605	886	580	861	178	110	-	42	37
CRN 5-11	2.2	632	953	607	928	178	110	-	43	39
CRN 5-12	2.2	659	980	634	955	178	110	-	43	39
CRN 5-13	2.2	686	1007	661	982	178	110	-	44	40
CRN 5-14	2.2	713	1034	688	1009	178	110	-	45	40
CRN 5-15	2.2	740	1061	715	1036	178	110	-	45	41
CRN 5-16	3	767	1102	742	1077	178	110	-	49	44
CRN 5-18	3	825	1160	800	1135	198	120	-	51	47
CRN 5-20	3	879	1214	854	1189	198	120	-	52	48
CRN 5-22	4	933	1305	908	1280	220	134	-	65	61
CRN 5-24	4	987	1359	962	1334	220	134	-	67	62
CRN 5-26	4	1041	1413	1016	1388	220	134	-	68	64
CRN 5-29	5.5	1122	1513	1097	1488	220	134	300	77	72
CRN 5-32	5.5	1254	1645	1229	1620	220	134	300	92	88
CRN 5-36	5.5	1362	1753	1337	1728	220	134	300	94	90

CRN 10 - MAGdrive, 50 Hz

Pump type	Motor P2 [kW]	Dimension [mm]						Net weight [kg]		
		DIN flange		Oval flange		D1	D2	D3	DIN flange	Oval flange
		B1	B1 + B2	B1	B1 + B2					
CRN 10-1	0.55	443	634	443	634	141	109	-	40	36
CRN 10-2	0.75	447	678	447	678	141	109	-	41	38
CRN 10-3	1.1	477	708	477	708	141	109	-	45	41
CRN 10-4	1.5	523	804	523	804	178	110	-	53	49
CRN 10-5	2.2	553	874	553	874	178	110	-	55	51
CRN 10-6	2.2	583	904	583	904	178	110	-	56	52
CRN 10-7	3	618	953	618	953	198	120	-	61	57
CRN 10-8	3	648	983	648	983	198	120	-	62	59
CRN 10-9	4	678	1050	678	1050	198	120	-	74	71
CRN 10-10	4	708	1080	708	1080	220	134	-	74	71
CRN 10-12	5.5	768	1159	768	1159	220	134	300	76	73
CRN 10-14	5.5	860	1251	860	1251	220	134	300	99	95
CRN 10-16	5.5	920	1311	920	1311	220	134	300	101	97
CRN 10-18	7.5	980	1359	980	1359	260	159	300	121	118
CRN 10-20	7.5	1040	1419	1040	1419	260	159	300	123	120
CRN 10-22	11	1100	1571	1100	1571	314	204	350	191	157

CRN 15 - MAGdrive, 50 Hz

Pump type	Motor P2 [kW]	Dimension [mm]						Net weight [kg]		
		DIN flange		Oval flange		D1	D2	D3	DIN flange	Oval flange
		B1	B1 + B2	B1	B1 + B2					
CRN 15-1	1.1	490	721	490	721	141	109	-	45	40
CRN 15-2	2.2	505	826	505	826	178	110	-	53	48
CRN 15-3	3	555	890	555	890	198	120	-	59	54
CRN 15-4	4	600	972	600	972	220	134	-	71	67
CRN 15-5	5.5	645	1036	645	1036	220	134	300	73	68
CRN 15-6	5.5	722	1113	722	1113	220	134	300	95	90
CRN 15-7	7.5	767	1146	767	1146	260	159	300	111	107
CRN 15-8	7.5	812	1191	812	1191	260	159	300	115	110
CRN 15-9	7.5	857	1236	857	1236	260	159	300	117	112
CRN 15-10	11	979	1450	979	1450	314	204	350	141	136
CRN 15-12	11	1069	1540	1069	1540	314	204	350	143	139
CRN 15-14	15	1159	1630	1159	1630	314	204	350	165	161
CRN 15-17	15	1294	1765	1294	1765	314	204	350	184	180

CRN 20 - MAGdrive, 50 Hz

Pump type	Motor P2 [kW]	Dimension [mm]						Net weight [kg]		
		DIN flange		Oval flange		D1	D2	D3	DIN flange	Oval flange
		B1	B1 + B2	B1	B1 + B2					
CRN 20-1	1.1	487	718	487	718	141	109	-	46	41
CRN 20-2	2.2	503	824	503	824	178	110	-	54	49
CRN 20-3	4	553	925	553	925	220	134	-	71	66
CRN 20-4	5.5	630	1021	630	1021	220	134	300	93	88
CRN 20-5	5.5	675	1066	675	1066	220	134	300	94	89
CRN 20-6	7.5	720	1099	720	1099	260	159	300	113	108
CRN 20-7	7.5	765	1144	765	1144	260	159	300	114	110
CRN 20-8	11	887	1358	887	1358	314	204	350	137	132
CRN 20-10	11	977	1448	977	1448	314	204	350	141	136
CRN 20-12	15	1067	1538	1067	1538	314	204	350	176	171
CRN 20-14	15	1157	1628	1157	1628	314	204	350	179	175
CRN 20-17	18.5	1292	1807	1292	1807	314	204	350	206	202

CRN 32 - MAGdrive, 50 Hz

Pump type	Motor P2 [kW]	Dimension [mm]					Net weight [kg]
		DIN flange		D1	D2	D3	
		B1	B1 + B2				
CRN 32-1-1	1.5	505	786	178	110	270	69
CRN 32-1	2.2	505	826	178	110	270	69
CRN 32-2-2	3	575	910	198	120	270	76
CRN 32-2	4	575	947	220	134	270	87
CRN 32-3-2	5.5	666	1057	220	134	300	102
CRN 32-3	5.5	666	1057	220	134	300	102
CRN 32-4-2	7.5	715	1094	260	159	300	121
CRN 32-4	7.5	715	1094	260	159	300	121
CRN 32-5-2	11	895	1366	314	204	350	148
CRN 32-5	11	895	1366	314	204	350	148
CRN 32-6-2	11	965	1436	314	204	350	151
CRN 32-6	11	965	1436	314	204	350	151
CRN 32-7-2	15	1035	1506	314	204	350	193
CRN 32-7	15	1035	1506	314	204	350	193
CRN 32-8-2	15	1105	1576	314	204	350	199
CRN 32-8	15	1105	1576	314	204	350	199
CRN 32-9-2	18.5	1175	1690	314	204	350	199
CRN 32-9	18.5	1175	1690	314	204	350	199
CRN 32-10-2	18.5	1245	1760	314	204	350	202
CRN 32-10	18.5	1245	1760	314	204	350	202
CRN 32-11-2	22	1315	1856	314	204	350	276
CRN 32-11	22	1315	1856	314	204	350	176
CRN 32-12-2	22	1385	1926	314	204	350	280
CRN 32-12	22	1385	1926	314	204	350	280

CRN 32 pumps are also available with PJE connection.

CRN 45 - MAGdrive, 50 Hz

Pump type	Motor P2 [kW]	Dimension [mm]					Net weight [kg]
		DIN flange		D1	D2	D3	
		B1	B1 + B2				
CRN 45-1-1	3	559	894	198	120	270	81
CRN 45-1	4	559	931	220	134	270	92
CRN 45-2-2	5.5	660	1051	220	134	300	107
CRN 45-2	7.5	639	1018	260	159	300	121
CRN 45-3-2	11	829	1300	314	204	350	153
CRN 45-3	11	829	1300	314	204	350	153
CRN 45-4-2	15	909	1380	314	204	350	185
CRN 45-4	15	909	1380	314	204	350	195
CRN 45-5-2	18.5	989	1504	314	204	350	195
CRN 45-5	18.5	989	1504	314	204	350	195
CRN 45-6-2	22	1069	1610	314	204	350	273
CRN 45-6	22	1069	1610	314	204	350	273

CRN 45 pumps are also available with PJE connection.

CRN 64 - MAGdrive, 50 Hz

Pump type	Motor P2 [kW]	Dimension [mm]						Net weight [kg]
		DIN flange		D1	D2	D3	DIN flange	
		B1	B1 + B2					
CRN 64-1-1	4	561	933	220	134	270	95	
CRN 64-1	7.5	561	940	260	159	300	118	
CRN 64-2-2	11	644	1115	314	204	350	152	
CRN 64-2-1	11	754	1225	314	204	350	152	
CRN 64-2	15	754	1225	314	204	350	170	
CRN 64-3-2	15	836	1307	314	204	350	193	
CRN 64-3-1	18.5	836	1351	314	204	350	191	
CRN 64-3	18.5	836	1351	314	204	350	191	
CRN 64-4-2	22	919	1460	314	204	350	266	
CRN 64-4-1	22	919	1460	314	204	350	266	

CRN 64 pumps are also available with PJE connection.

CRN 1s - MAGdrive, 60 Hz

Pump type	Motor P2 [kW]	Dimension [mm]							Net weight [kg]	
		DIN flange		Oval flange		D1	D2	D3	DIN flange	Oval flange
		B1	B1 + B2	B1	B1 + B2					
CRN1s-2	0.37	367	558	342	533	141	109	-	24	20
CRN1s-3	0.37	367	558	342	533	141	109	-	25	20
CRN1s-4	0.37	385	576	360	551	141	109	-	25	21
CRN1s-5	0.37	403	594	378	569	141	109	-	25	21
CRN1s-6	0.55	421	612	396	587	141	109	-	27	23
CRN1s-7	0.55	439	630	414	605	141	109	-	27	23
CRN1s-8	0.55	457	648	432	623	141	109	-	28	23
CRN1s-9	0.75	475	666	450	641	141	109	-	29	25
CRN1s-10	0.75	493	684	468	659	141	109	-	29	25
CRN1s-11	0.75	511	702	486	677	141	109	-	30	25
CRN1s-12	0.75	529	720	504	695	141	109	-	30	26
CRN1s-13	0.75	547	738	522	713	141	109	-	31	26
CRN1s-15	1.1	583	774	558	749	141	109	-	40	36
CRN1s-17	1.1	619	810	594	785	141	109	-	40	36
CRN1s-19	1.1	655	886	630	861	141	109	-	41	36
CRN1s-21	1.5	713	994	688	969	178	110	-	44	39
CRN1s-23	1.5	749	1030	724	1005	178	110	-	44	40
CRN1s-25	1.5	785	1066	760	1041	178	110	-	44	40
CRN1s-27	2.2	821	1142	796	1117	178	110	-	45	41

CRN 1 - MAGdrive, 60 Hz

Pump type	Motor P2 [kW]	Dimension [mm]						Net weight [kg]		
		DIN flange		Oval flange		D1	D2	D3	DIN flange	Oval flange
		B1	B1 + B2	B1	B1 + B2					
CRN1-2	0.37	367	558	342	533	141	109	-	24	20
CRN1-3	0.37	367	558	342	533	141	109	-	25	20
CRN1-4	0.55	385	576	360	551	141	109	-	26	22
CRN1-5	0.55	403	594	378	569	141	109	-	26	22
CRN1-6	0.75	421	612	396	587	141	109	-	28	24
CRN1-7	0.75	439	630	414	605	141	109	-	28	24
CRN1-8	0.75	457	648	432	623	141	109	-	28	24
CRN1-9	1.1	475	666	450	641	141	109	-	37	33
CRN1-10	1.1	493	684	468	659	141	109	-	37	33
CRN1-11	1.1	511	742	486	717	141	109	-	37	33
CRN1-12	1.1	535	766	510	741	141	109	-	39	35
CRN1-13	1.5	569	850	544	825	178	110	-	41	36

Pump type	Motor P2 [kW]	Dimension [mm]							Net weight [kg]	
		DIN flange		Oval flange		D1	D2	D3	DIN flange	Oval flange
		B1	B1 + B2	B1	B1 + B2					
CRN1-15	1.5	605	886	580	861	178	110	-	41	37
CRN1-17	1.5	641	922	616	897	178	110	-	42	38
CRN1-19	2.2	677	998	652	973	178	110	-	42	38
CRN1-21	2.2	713	1034	688	1009	178	110	-	43	39
CRN1-23	2.2	749	1070	724	1045	178	110	-	44	40
CRN1-25	3	790	1125	765	1100	198	120	-	54	50
CRN1-27	3	826	1161	801	1136	198	120	-	55	51

CRN 3 - MAGdrive, 60 Hz

Pump type	Motor P2 [kW]	Dimension [mm]							Net weight [kg]	
		DIN flange		Oval flange		D1	D2	D3	DIN flange	Oval flange
		B1	B1 + B2	B1	B1 + B2					
CRN3-2	0.37	367	558	342	533	141	109	-	24	20
CRN3-3	0.55	367	558	342	533	141	109	-	26	21
CRN3-4	0.75	385	576	360	551	141	109	-	27	23
CRN3-5	0.75	403	594	378	569	141	109	-	27	23
CRN3-6	1.1	421	612	396	587	141	109	-	36	31
CRN3-7	1.1	439	630	414	605	141	109	-	36	32
CRN3-8	1.1	463	694	438	669	141	109	-	38	33
CRN3-9	1.5	497	778	472	753	178	110	-	39	35
CRN3-10	1.5	515	796	490	771	178	110	-	39	35
CRN3-11	1.5	533	814	508	789	178	110	-	39	35
CRN3-12	2.2	551	872	526	847	178	110	-	39	35
CRN3-13	2.2	569	890	544	865	178	110	-	40	36
CRN3-15	2.2	605	926	580	901	178	110	-	41	36
CRN3-17	3	646	981	621	956	198	120	-	51	47
CRN3-19	3	682	1017	657	992	198	120	-	52	47
CRN3-21	3	718	1053	693	1028	198	120	-	52	48
CRN3-23	4	754	1126	729	1101	198	120	-	69	65
CRN3-25	4	790	1162	765	1137	198	120	-	70	65

CRN 5 - MAGdrive, 60 Hz

Pump type	Motor P2 [kW]	Dimension [mm]							Net weight [kg]	
		DIN flange		Oval flange		D1	D2	D3	DIN flange	Oval flange
		B1	B1 + B2	B1	B1 + B2					
CRN5-2	0.75	367	558	342	533	141	109	-	27	22
CRN5-3	1.1	394	585	369	560	141	109	-	35	31
CRN5-4	1.1	421	652	396	627	141	109	-	35	31
CRN5-5	1.5	470	751	445	726	178	110	-	39	35
CRN5-6	2.2	497	818	472	793	178	110	-	39	35
CRN5-7	2.2	524	845	499	820	178	110	-	39	35
CRN5-8	2.2	551	872	526	847	178	110	-	40	36
CRN5-9	3	583	918	558	893	198	120	-	49	45
CRN5-10	3	610	945	585	920	198	120	-	50	45
CRN5-11	3	637	972	612	947	198	120	-	50	46
CRN5-12	4	664	1036	639	1011	198	120	-	65	61
CRN5-13	4	691	1063	666	1038	198	120	-	66	62
CRN5-14	4	719	1089.6	694	1064.6	198	120	-	67	62
CRN5-15	4	745	1116.6	720	1091.6	198	120	-	67	62
CRN5-16	5.5	817	1208.4	792	1183.4	220	134	300	76	71
CRN5-18	5.5	875	1266.4	850	1241.4	220	134	300	76	72
CRN5-20	5.5	929	1320.4	904	1295.4	220	134	300	77	73

CRN 10 - MAGdrive, 60 Hz

Pump type	Motor P2 [kW]	Dimension [mm]							Net weight [kg]	
		DIN flange		Oval flange		D1	D2	D3	DIN flange	Oval flange
		B1	B1 + B2	B1	B1 + B2					
CRN10-1	0.75	443	634	443	634	141	109	-	41	37
CRN10-2	1.5	463	743.5	463	743.5	178	110	-	50	47
CRN10-3	2.2	493	813.5	493	813.5	178	110	-	51	47
CRN10-4	3	528	863	528	863	198	120	-	61	57
CRN10-5	4	558	930	558	930	198	120	-	78	74
CRN10-6	4	588	1026	588	1026	198	120	-	79	75
CRN10-7	5.5	635	1026	635	1026	220	134	300	86	82
CRN10-8	5.5	665	1056	665	1056	220	134	300	87	84
CRN10-9	7.5	695	1074	695	1074	260	159	300	97	94
CRN10-10	7.5	725	1104	725	1104	260	159	300	97	94
CRN10-12	7.5	785	1164	785	1164	260	159	300	97	94
CRN10-14	11	902	1373	902	1373	314	204	350	152	148
CRN10-16	11	962	1433	962	1433	314	204	350	154	150

CRN 15 - MAGdrive, 60 Hz

Pump type	Motor P2 [kW]	Dimension [mm]							Net weight [kg]	
		DIN flange		Oval flange		D1	D2	D3	DIN flange	Oval flange
		B1	B1 + B2	B1	B1 + B2					
CRN15-1	1.5	506	786.5	506	786.5	178	110	-	46	41
CRN15-2	3	510	845	510	845	198	120	-	56	51
CRN15-3	5.5	572	963	572	963	220	134	300	75	70
CRN15-4	7.5	617	996	617	996	260	159	300	87	83
CRN15-5	7.5	645	1024	645	1024	260	159	300	87	83
CRN15-6	11	764	1235	764	1235	314	204	350	148	143
CRN15-7	11	809	1280	809	1280	314	204	350	152	148
CRN15-8	15	854	1325	854	1325	314	204	350	173	168
CRN15-9	15	899	1370	899	1370	314	204	350	175	170
CRN15-10	15	979	1450	979	1450	314	204	350	175	170
CRN15-12	18.5	1069	1584	1069	1584	314	204	350	169	164

CRN 20 - MAGdrive, 60 Hz

Pump type	Motor P2 [kW]	Dimension [mm]							Net weight [kg]	
		DIN flange		Oval flange		D1	D2	D3	DIN flange	Oval flange
		B1	B1 + B2	B1	B1 + B2					
CRN20-1	2.2	503	823.5	503	823.5	178	110	-	52	47
CRN20-2	4	508	880	508	880	198	120	-	76	71
CRN20-3	7.5	570	949	570	949	260	159	300	87	82
CRN20-4	11	740	1211	740	1211	314	204	350	146	141
CRN20-5	11	785	1256	785	1256	314	204	350	147	142
CRN20-6	15	830	1301	830	1301	314	204	350	170	165
CRN20-7	15	875	1346	875	1346	314	204	350	171	167
CRN20-8	18.5	887	1402	887	1402	314	204	350	163	159

CRN 32 - MAGdrive, 60 Hz

Pump type	Motor P2 [kW]	Dimension [mm]					Net weight [kg]
		DIN flange		D1	D2	D3	DIN flange
		B1	B1 + B2				
CRN32-1-1	3	505	840	198	120	-	77
CRN32-1	5.5	505	896	220	134	300	96
CRN32-2-2	5.5	575	966	220	134	300	101
CRN 32-2-1	5.5	575	966	220	134	300	101
CRN32-2	7.5	575	954	260	159	300	108
CRN32-3-2	11	690	1161	314	204	350	155
CRN32-3	11	690	1161	314	204	350	155
CRN32-4-2	15	757	1228	314	204	350	179
CRN32-4	15	757	1228	314	204	350	179
CRN32-5-2	15	895	1366	314	204	350	180
CRN32-5	18.5	895	1410	314	204	350	172
CRN32-6-2	18.5	965	1480	314	204	350	172
CRN32-6	22	965	1506	314	204	350	238
CRN32-7-2	22	1035	1576	314	204	350	266
CRN32-7	22	1035	1576	314	204	350	266

CRN 32 pumps are also available with PJE connection.

CRN 45 - MAGdrive, 60 Hz

Pump type	Motor P2 [kW]	Dimension [mm]					Net weight [kg]
		DIN flange		D1	D2	D3	DIN flange
		B1	B1 + B2				
CRN45-1-1	5.5	559	950	220	134	300	106
CRN45-1	7.5	559	938	260	159	300	116
CRN45-2-2	11	770	1241	314	204	350	160
CRN45-2-1	15	749	1220	314	204	350	178
CRN45-2	15	749	1220	314	204	350	178
CRN45-3-2	18.5	829	1344	314	204	350	169
CRN45-3-1	18.5	829	1344	314	204	350	169
CRN45-3	18.5	829	1344	314	204	350	169
CRN45-4-2	22	909	1450	314	204	350	268

CRN 45 pumps are also available with PJE connection.

CRN 64 - MAGdrive, 60 Hz

Pump type	Motor P2 [kW]	Dimension [mm]					Net weight [kg]
		DIN flange		D1	D2	D3	DIN flange
		B1	B1 + B2				
CRN64-1-1	7.5	561	940	260	159	300	111
CRN64-1	11	671	1142	314	204	350	158
CRN64-2-2	15	644	1115	314	204	350	173
CRN64-2-1	18.5	754	1269	314	204	350	168
CRN64-2	22	754	1295	314	204	350	243

CRN 64 pumps are also available with PJE connection.

CR-H, CRN-H pumps

Dimensional drawings for CR-H, CRN-H pumps

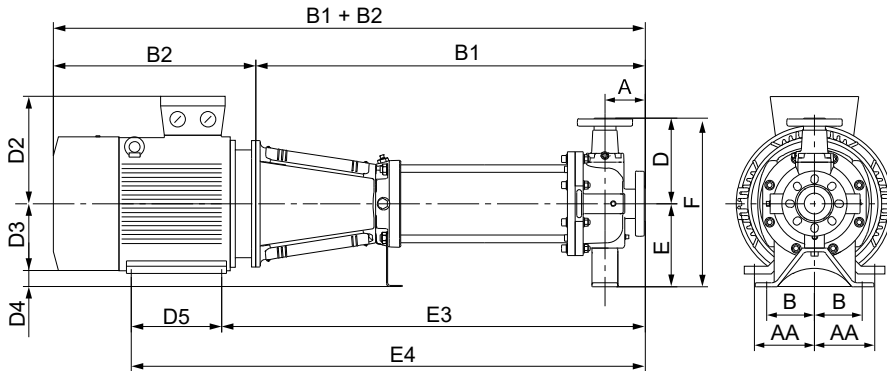

TM051523

CR-H, CRN-H 1s-90

Dimensions of mounting plates for CR-H, CRN-H pumps

	CR-H, CRN-H 1s-5	CR-H, CRN-H 10-20	CR-H, CRN-H 32	CR-H, CRN-H 45	CR-H, CRN-H 64-90
Inlet [mm]	40	50	50	80	100
Outlet [mm]	25	50	50	80	100
Ref.	Dim. [mm]				
A	102	102	102	102	102
B	76	124	124	124	124
AA	According to specifications for CR horizontal pumps				
D	165	191	191	229	280
E	134	210	210	210	210
F	299	401	401	439	490
Note	Ref. AA is only applicable with motors 5.5 - 45 kW.				

Dimensions and weights

CR-H, CRN-H 1s, 50 Hz

Pump type	Motor P2 [kW]	Dimension [mm]									Net weight [kg]	
		DIN flange			D2	D3	D4	D5	E3	E4	DIN CR	DIN CRN
		B1	B2	B1 + B2								
CR-H, CRN-H 1s-2	0.37	309	191	500	109	71	63	-	-	-	24	21
CR-H, CRN-H 1s-3	0.37	309	191	500	109	71	63	-	-	-	24	22
CR-H, CRN-H 1s-4	0.37	327	191	518	109	71	63	-	-	-	25	22
CR-H, CRN-H 1s-5	0.37	345	191	536	109	71	63	-	-	-	25	22
CR-H, CRN-H 1s-6	0.37	363	191	554	109	71	63	-	-	-	26	23
CR-H, CRN-H 1s-7	0.37	381	191	572	109	71	63	-	-	-	26	23
CR-H, CRN-H 1s-8	0.37	399	191	590	109	71	63	-	-	-	26	23
CR-H, CRN-H 1s-9	0.37	417	191	608	109	71	63	-	-	-	27	24
CR-H, CRN-H 1s-10	0.37	435	191	626	109	71	63	-	-	-	27	24
CR-H, CRN-H 1s-11	0.37	453	191	644	109	71	63	-	-	-	27	25
CR-H, CRN-H 1s-12	0.37	471	191	662	109	71	63	-	-	-	28	25
CR-H, CRN-H 1s-13	0.37	489	191	680	109	71	63	-	-	-	28	25
CR-H, CRN-H 1s-15	0.55	525	191	716	109	71	63	-	-	-	30	27
CR-H, CRN-H 1s-17	0.55	561	191	752	109	71	63	-	-	-	31	28
CR-H, CRN-H 1s-19	0.55	597	191	788	109	71	63	-	-	-	31	28
CR-H, CRN-H 1s-21	0.75	655	231	886	109	80	54	-	-	-	34	32
CR-H, CRN-H 1s-23	0.75	691	231	922	109	80	54	-	-	-	35	32
CR-H, CRN-H 1s-25	0.75	727	231	958	109	80	54	-	-	-	35	33

Pump type	Motor P2 [kW]	Dimension [mm]										Net weight [kg]	
		DIN flange			D2	D3	D4	D5	E3	E4	DIN	DIN	
		B1	B2	B1 + B2							CR	CRN	
CR-H, CRN-H 1s-27	1.1	763	231	994	109	80	54	-	-	-	38	36	
CR-H, CRN-H 1s-30	1.1	817	231	1048	109	80	54	-	-	-	40	37	
CR-H, CRN-H 1s-33	1.1	871	231	1102	109	80	54	-	-	-	41	38	
CR-H, CRN-H 1s-36	1.1	925	231	1156	109	80	54	-	-	-	42	40	

CR-H, CRN-H 1, 50 Hz

Pump type	Motor P2 [kW]	Dimension [mm]										Net weight [kg]	
		DIN flange			D2	D3	D4	D5	E3	E4	DIN	DIN	
		B1	B2	B1 + B2							CR	CRN	
CR-H, CRN-H 1-2	0.37	309	191	500	109	71	63	-	-	-	24	21	
CR-H, CRN-H 1-3	0.37	309	191	500	109	71	63	-	-	-	24	22	
CR-H, CRN-H 1-4	0.37	327	191	518	109	71	63	-	-	-	25	22	
CR-H, CRN-H 1-5	0.37	345	191	536	109	71	63	-	-	-	25	22	
CR-H, CRN-H 1-6	0.37	363	191	554	109	71	63	-	-	-	26	23	
CR-H, CRN-H 1-7	0.37	381	191	572	109	71	63	-	-	-	26	23	
CR-H, CRN-H 1-8	0.55	399	191	590	109	71	63	-	-	-	27	24	
CR-H, CRN-H 1-9	0.55	417	191	608	109	71	63	-	-	-	27	25	
CR-H, CRN-H 1-10	0.55	435	191	626	109	71	63	-	-	-	28	25	
CR-H, CRN-H 1-11	0.55	453	191	644	109	71	63	-	-	-	28	25	
CR-H, CRN-H 1-12	0.75	477	231	708	109	80	54	-	-	-	30	28	
CR-H, CRN-H 1-13	0.75	495	231	726	109	80	54	-	-	-	31	28	
CR-H, CRN-H 1-15	0.75	531	231	762	109	80	54	-	-	-	32	29	
CR-H, CRN-H 1-17	1.1	567	231	798	109	80	54	-	-	-	35	32	
CR-H, CRN-H 1-19	1.1	603	231	834	109	80	54	-	-	-	36	33	
CR-H, CRN-H 1-21	1.1	639	231	870	109	80	54	-	-	-	36	34	
CR-H, CRN-H 1-23	1.1	675	231	906	109	80	54	-	-	-	37	35	
CR-H, CRN-H 1-25	1.5	727	321	1048	110	90	44	-	-	-	45	42	
CR-H, CRN-H 1-27	1.5	763	321	1084	110	90	44	-	-	-	46	43	
CR-H, CRN-H 1-30	1.5	817	321	1138	110	90	44	-	-	-	47	44	
CR-H, CRN-H 1-33	2.2	871	321	1192	110	90	44	-	-	-	49	46	
CR-H, CRN-H 1-36	2.2	925	321	1246	110	90	44	-	-	-	50	47	

CR-H, CRN-H 3, 50 Hz

Pump type	Motor P2 [kW]	Dimension [mm]										Net weight [kg]	
		DIN flange			D2	D3	D4	D5	E3	E4	DIN	DIN	
		B1	B2	B1 + B2							CR	CRN	
CR-H, CRN-H 3-2	0.37	309	191	500	109	71	63	-	-	-	24	21	
CR-H, CRN-H 3-3	0.37	309	191	500	109	71	63	-	-	-	24	22	
CR-H, CRN-H 3-4	0.37	327	191	518	109	71	63	-	-	-	25	22	
CR-H, CRN-H 3-5	0.37	345	191	536	109	71	63	-	-	-	25	22	
CR-H, CRN-H 3-6	0.55	363	191	554	109	71	63	-	-	-	26	23	
CR-H, CRN-H 3-7	0.55	381	191	572	109	71	63	-	-	-	27	24	
CR-H, CRN-H 3-8	0.75	405	231	636	109	80	54	-	-	-	29	26	
CR-H, CRN-H 3-9	0.75	423	231	654	109	80	54	-	-	-	29	27	
CR-H, CRN-H 3-10	0.75	441	231	672	109	80	54	-	-	-	30	27	
CR-H, CRN-H 3-11	1.1	459	231	690	109	80	54	-	-	-	32	30	
CR-H, CRN-H 3-12	1.1	477	231	708	109	80	54	-	-	-	33	30	
CR-H, CRN-H 3-13	1.1	495	231	726	109	80	54	-	-	-	33	31	
CR-H, CRN-H 3-15	1.1	531	231	762	109	80	54	-	-	-	34	32	
CR-H, CRN-H 3-17	1.5	583	321	904	110	90	44	-	-	-	42	39	
CR-H, CRN-H 3-19	1.5	619	321	940	110	90	44	-	-	-	43	40	
CR-H, CRN-H 3-21	2.2	655	321	976	110	90	44	-	-	-	44	41	
CR-H, CRN-H 3-23	2.2	691	321	1012	110	90	44	-	-	-	45	42	

Pump type	Motor P2 [kW]	Dimension [mm]									Net weight [kg]	
		DIN flange			D2	D3	D4	D5	E3	E4	DIN	DIN
		B1	B2	B1 + B2							CR	CRN
CR-H, CRN-H 3-25	2.2	727	321	1048	110	90	44	-	-	-	46	42
CR-H, CRN-H 3-27	2.2	763	321	1084	110	90	44	-	-	-	46	43
CR-H, CRN-H 3-29	2.2	799	321	1120	110	90	44	-	-	-	47	44
CR-H, CRN-H 3-31	3	840	335	1175	120	100	34	-	-	-	54	51
CR-H, CRN-H 3-33	3	876	335	1211	120	100	34	-	-	-	55	52
CR-H, CRN-H 3-36	3	930	335	1265	120	100	34	-	-	-	56	53

CR-H, CRN-H 5, 50 Hz

Pump type	Motor P2 [kW]	Dimension [mm]									Net weight [kg]	
		DIN flange			D2	D3	D4	D5	E3	E4	DIN	DIN
		B1	B2	B1 + B2							CR	CRN
CR-H, CRN-H 5-2	0.37	309	191	500	109	71	63	-	-	-	24	21
CR-H, CRN-H 5-3	0.55	336	191	527	109	71	63	-	-	-	26	23
CR-H, CRN-H 5-4	0.55	363	191	554	109	71	63	-	-	-	26	23
CR-H, CRN-H 5-5	0.75	396	231	627	109	80	54	-	-	-	28	26
CR-H, CRN-H 5-6	1.1	423	231	654	109	80	54	-	-	-	31	29
CR-H, CRN-H 5-7	1.1	450	231	681	109	80	54	-	-	-	32	29
CR-H, CRN-H 5-8	1.1	477	231	708	109	80	54	-	-	-	32	30
CR-H, CRN-H 5-9	1.5	520	321	841	110	90	44	-	-	-	40	37
CR-H, CRN-H 5-10	1.5	547	321	868	110	90	44	-	-	-	40	38
CR-H, CRN-H 5-11	2.2	574	321	895	110	90	44	-	-	-	42	39
CR-H, CRN-H 5-12	2.2	601	321	922	110	90	44	-	-	-	42	39
CR-H, CRN-H 5-13	2.2	628	321	949	110	90	44	-	-	-	43	40
CR-H, CRN-H 5-14	2.2	655	321	976	110	90	44	-	-	-	43	40
CR-H, CRN-H 5-15	2.2	682	321	1003	110	90	44	-	-	-	44	41
CR-H, CRN-H 5-16	2.2	709	321	1030	110	90	44	-	-	-	45	41
CR-H, CRN-H 5-18	3	768	335	1103	120	100	34	-	-	-	52	49
CR-H, CRN-H 5-20	3	822	335	1157	120	100	34	-	-	-	53	50
CR-H, CRN-H 5-22	4	876	372	1248	134	112	22	-	-	-	63	60
CR-H, CRN-H 5-24	4	930	372	1302	134	112	22	-	-	-	64	62
CR-H, CRN-H 5-26	4	984	372	1356	134	112	22	-	-	-	66	63
CR-H, CRN-H 5-29	4	1065	372	1437	134	112	22	-	-	-	67	64
CR-H, CRN-H 5-32	5.5	1175	391	1566	134	132	2	140	1294	1434	83	80
CR-H, CRN-H 5-36	5.5	1283	391	1674	134	132	2	140	1402	1542	86	82

CR-H, CRN-H 10, 50 Hz

Pump type	Motor P2 [kW]	Dimension [mm]									Net weight [kg]	
		DIN flange			D2	D3	D4	D5	E3	E4	DIN	DIN
		B1	B2	B1 + B2							CR	CRN
CR-H, CRN-H 10-1	0.37	414	191	605	109	71	139	-	-	-	58	52
CR-H, CRN-H 10-2	0.75	430	231	661	109	80	130	-	-	-	60	54
CR-H, CRN-H 10-3	1.1	464	231	695	109	80	130	-	-	-	63	58
CR-H, CRN-H 10-4	1.5	494	321	815	109	90	120	-	-	-	71	66
CR-H, CRN-H 10-5	2.2	524	321	845	110	90	120	-	-	-	73	68
CR-H, CRN-H 10-6	2.2	584	321	905	110	90	120	-	-	-	74	69
CR-H, CRN-H 10-7	3	614	335	949	120	100	110	-	-	-	81	76
CR-H, CRN-H 10-8	3	644	335	979	120	100	110	-	-	-	82	77
CR-H, CRN-H 10-9	3	674	335	1009	120	100	110	-	-	-	83	78
CR-H, CRN-H 10-10	4	816	372	1188	134	112	98	-	-	-	93	88
CR-H, CRN-H 10-12	4	876	372	1248	134	112	98	-	-	-	95	90
CR-H, CRN-H 10-14	5.5	936	391	1327	134	132	78	140	1055	1195	118	113
CR-H, CRN-H 10-16	5.5	996	391	1387	134	132	78	140	1115	1255	120	115
CR-H, CRN-H 10-18	7.5	1056	379	1435	159	132	78	178	1125	1303	133	128
CR-H, CRN-H 10-20	7.5	1116	379	1495	159	132	78	178	1185	1363	136	130
CR-H, CRN-H 10-22	7.5	1176	379	1555	159	132	78	178	1245	1423	138	132

CR-H, CRN-H 15, 50 Hz

Pump type	Motor P2 [kW]	Dimension [mm]									Net weight [kg]	
		DIN flange			D2	D3	D4	D5	E3	E4	DIN	DIN
		B1	B2	B1 + B2							CR	CRN
CR-H, CRN-H 15-1	1.1	442	231	673	109	80	130	-	-	-	62	57
CR-H, CRN-H 15-2	2.2	458	231	689	110	90	120	-	-	-	70	65
CR-H, CRN-H 15-3	3	508	335	843	120	100	110	-	-	-	77	73
CR-H, CRN-H 15-4	4	553	372	925	134	112	98	-	-	-	88	83
CR-H, CRN-H 15-5	4	598	372	970	134	112	98	-	-	-	89	85
CR-H, CRN-H 15-6	5.5	672	391	1063	134	132	78	140	791	931	111	107
CR-H, CRN-H 15-7	5.5	717	391	1108	134	132	78	140	836	0	113	108
CR-H, CRN-H 15-8	7.5	762	379	1141	159	132	78	178	831	0	125	121
CR-H, CRN-H 15-9	7.5	807	379	1186	159	132	78	178	876	0	127	122
CR-H, CRN-H 15-10	11	965	471	1436	204	160	50	210	1103	0	169	165
CR-H, CRN-H 15-12	11	1055	471	1526	204	160	50	210	1193	0	173	168
CR-H, CRN-H 15-14	11	1145	471	1616	204	160	50	210	1283	0	177	171
CR-H, CRN-H 15-17	11	1280	471	1751	204	160	50	210	1418	0	195	189

CR-H, CRN-H 20, 50 Hz

Pump type	Motor P2 [kW]	Dimension [mm]									Net weight [kg]	
		DIN flange			D2	D3	D4	D5	E3	E4	DIN	DIN
		B1	B2	B1 + B2							CR	CRN
CR-H, CRN-H 20-1	1.1	509	231	740	109	80	130	-	-	-	62	57
CR-H, CRN-H 20-2	2.2	525	321	846	110	90	120	-	-	-	70	65
CR-H, CRN-H 20-3	4	575	372	947	134	112	98	-	-	-	86	82
CR-H, CRN-H 20-4	5.5	649	391	1040	134	132	78	140	768	908	108	104
CR-H, CRN-H 20-5	5.5	694	391	1085	134	132	78	140	813	953	110	105
CR-H, CRN-H 20-6	7.5	739	379	1118	159	132	78	178	808	986	122	117
CR-H, CRN-H 20-7	7.5	784	379	1163	159	132	78	178	853	1031	123	119
CR-H, CRN-H 20-8	11	942	471	1413	204	160	50	210	1080	1290	166	161
CR-H, CRN-H 20-10	11	1032	471	1503	204	160	50	210	1170	1380	169	165
CR-H, CRN-H 20-12	15	1122	471	1593	204	160	50	210	1260	1470	186	181
CR-H, CRN-H 20-14	15	1212	471	1683	204	160	50	210	1350	1560	190	184
CR-H, CRN-H 20-17	18.5	1347	545	1892	204	180	30	254	1485	1739	208	202

CR-H, CRN-H 32, 50 Hz

Pump type	Motor P2 [kW]	Dimension [mm]									Net weight [kg]	
		DIN flange			D2	D3	D4	D5	E3	E4	DIN	DIN
		B1	B2	B1 + B2							CR	CRN
CR-H, CRN-H 32-1-1	1.5	533	321	854	110	90	120	-	-	-	81	77
CR-H, CRN-H 32-1	2.2	533	321	854	110	90	120	-	-	-	82	77
CR-H, CRN-H 32-2-2	3	603	335	938	120	100	110	-	-	-	90	86
CR-H, CRN-H 32-2	4	603	372	975	134	112	98	-	-	-	99	95
CR-H, CRN-H 32-3-2	5.5	673	391	1064	134	132	78	140	792	932	114	109
CR-H, CRN-H 32-3	5.5	673	391	1064	134	132	78	140	792	932	114	109
CR-H, CRN-H 32-4-2	7.5	743	391	1134	159	132	78	178	812	990	129	124
CR-H, CRN-H 32-4	7.5	743	391	1134	159	132	78	178	812	990	129	124
CR-H, CRN-H 32-5-2	11	923	471	1394	204	160	50	210	1061	1271	176	171
CR-H, CRN-H 32-5	11	923	471	1394	204	160	50	210	1061	1271	176	171
CR-H, CRN-H 32-6-2	11	993	471	1464	204	160	50	210	1131	1341	179	174
CR-H, CRN-H 32-6	11	993	471	1464	204	160	50	210	1131	1341	179	174
CR-H, CRN-H 32-7-2	15	1063	471	1534	204	160	50	210	1201	1411	195	190
CR-H, CRN-H 32-7	15	1063	471	1534	204	160	50	210	1201	1411	195	190
CR-H, CRN-H 32-8-2	15	1133	471	1604	204	160	50	210	1271	1481	201	196
CR-H, CRN-H 32-8	15	1133	471	1604	204	160	50	210	1271	1481	201	196
CR-H, CRN-H 32-9-2	18.5	1203	515	1718	204	160	50	254	1341	1595	217	213
CR-H, CRN-H 32-9	18.5	1203	515	1718	204	160	50	254	1341	1595	217	213
CR-H, CRN-H 32-10-2	18.5	1273	515	1788	204	160	50	254	1411	1665	220	216
CR-H, CRN-H 32-10	18.5	1273	515	1788	204	160	50	254	1411	1665	220	216
CR-H, CRN-H 32-11-2	22	1343	541	1884	204	180	30	241	1494	1735	238	233
CR-H, CRN-H 32-11	22	1343	541	1884	204	180	30	241	1494	1735	238	233
CR-H, CRN-H 32-12-2	22	1413	541	1954	204	180	30	241	1564	1805	241	237
CR-H, CRN-H 32-12	22	1413	541	1954	204	180	30	241	1564	1805	241	237
CR-H, CRN-H 32-13-2	30	1483	610	2093	300	200	10	305	1675	1980	347	342
CR-H, CRN-H 32-13	30	1483	610	2093	300	200	10	305	1675	1980	347	342
CR-H, CRN-H 32-14-2	30	1553	610	2163	300	200	10	305	1745	2050	350	345
CR-H, CRN-H 32-14	30	1553	610	2163	300	200	10	305	1745	2050	350	345

CR-H, CRN-H 45, 50 Hz

Pump type	Motor P2 [kW]	Dimension [mm]									Net weight [kg]	
		DIN flange			D2	D3	D4	D5	E3	E4	DIN	DIN
		B1	B2	B1 + B2							CR	CRN
CR-H, CRN-H 45-1-1	3	549	335	884	120	100	154	-	-	-	99	101
CR-H, CRN-H 45-1	4	549	372	921	134	112	142	-	-	-	108	110
CR-H, CRN-H 45-2-2	5.5	629	391	1020	134	132	122	140	748	888	123	125
CR-H, CRN-H 45-2	7.5	629	379	1008	159	132	122	178	698	876	135	137
CR-H, CRN-H 45-3-2	11	819	471	1290	204	160	94	210	957	1167	182	184
CR-H, CRN-H 45-3	11	819	471	1290	204	160	94	210	957	1167	182	184
CR-H, CRN-H 45-4-2	15	899	471	1370	204	160	94	210	1037	1247	199	201
CR-H, CRN-H 45-4	15	899	471	1370	204	160	94	210	1037	1247	199	201
CR-H, CRN-H 45-5-2	18.5	979	515	1494	204	160	94	254	1117	1371	216	218
CR-H, CRN-H 45-5	18.5	979	515	1494	204	160	94	254	1117	1371	216	218
CR-H, CRN-H 45-6-2	22	1059	541	1600	204	180	74	241	1210	1451	236	238
CR-H, CRN-H 45-6	22	1059	541	1600	204	180	74	241	1210	1451	236	238
CR-H, CRN-H 45-7-2	30	1139	610	1749	300	200	54	305	1331	1636	343	345
CR-H, CRN-H 45-7	30	1139	610	1749	300	200	54	305	1331	1636	343	345
CR-H, CRN-H 45-8-2	30	1219	610	1829	300	200	54	305	1411	1716	347	349
CR-H, CRN-H 45-8	30	1219	610	1829	300	200	54	305	1411	1716	347	349
CR-H, CRN-H 45-9-2	30	1299	610	1909	300	200	54	305	1491	1796	351	353
CR-H, CRN-H 45-9	37	1299	667	1966	300	200	54	305	1489	1794	381	383
CR-H, CRN-H 45-10-2	37	1379	667	2046	300	200	54	305	1569	1874	386	387

Pump type	Motor P2 [kW]	Dimension [mm]									Net weight [kg]	
		DIN flange			D2	D3	D4	D5	E3	E4	DIN	DIN
		B1	B2	B1 + B2							CR	CRN
CR-H, CRN-H 45-10	37	1379	667	2046	300	200	54	305	1569	1874	386	387
CR-H, CRN-H 45-11-2	45	1465	709	2174	325	225	29	286	1673	1959	474	476
CR-H, CRN-H 45-11	45	1459	709	2168	325	225	29	286	1667	1953	474	476
CR-H, CRN-H 45-12-2	45	1539	709	2248	325	225	29	286	1747	2033	479	480
CR-H, CRN-H 45-12	45	1539	709	2248	325	225	29	286	1747	2033	479	480
CR-H, CRN-H 45-13-2	45	1619	709	2328	325	225	29	286	1827	2113	483	485

CR-H, CRN-H 64, 50 Hz

Pump type	Motor P2 [kW]	Dimension [mm]									Net weight [kg]	
		DIN flange			D2	D3	D4	D5	E3	E4	DIN	DIN
		B1	B2	B1 + B2							CR	CRN
CR-H, CRN-H 64-1-1	4	580	372	952	134	112	142	-	-	-	121	114
CR-H, CRN-H 64-1	5.5	580	391	971	134	132	122	140	699	839	133	125
CR-H, CRN-H 64-2-2	7.5	662	379	1041	159	132	122	178	731	909	149	142
CR-H, CRN-H 64-2-1	11	772	471	1243	204	160	94	210	910	1120	193	186
CR-H, CRN-H 64-2	11	772	471	1243	204	160	94	210	910	1120	193	186
CR-H, CRN-H 64-3-2	15	854	471	1325	204	160	94	210	992	1202	210	203
CR-H, CRN-H 64-3-1	15	854	471	1325	204	160	94	210	992	1202	210	203
CR-H, CRN-H 64-3	18.5	854	515	1369	204	160	94	254	992	1246	223	216
CR-H, CRN-H 64-4-2	18.5	936	515	1451	204	160	94	254	1074	1328	228	221
CR-H, CRN-H 64-4-1	22	936	541	1477	204	180	74	241	1087	1328	242	234
CR-H, CRN-H 64-4	22	936	541	1477	204	180	74	241	1087	1328	242	234
CR-H, CRN-H 64-5-2	30	1018	610	1628	204	200	54	305	1210	1515	348	341
CR-H, CRN-H 64-5-1	30	1018	610	1628	300	200	54	305	1210	1515	348	341
CR-H, CRN-H 64-5	30	1018	610	1628	300	200	54	305	1210	1515	348	341
CR-H, CRN-H 64-6-2	30	1100	610	1710	300	200	54	305	1292	1597	354	348
CR-H, CRN-H 64-6-1	37	1100	667	1767	300	200	54	305	1292	1597	384	378
CR-H, CRN-H 64-6	37	1100	667	1767	300	200	54	305	1292	1597	384	378
CR-H, CRN-H 64-7-2	37	1182	667	1849	300	200	54	305	1374	1679	389	382
CR-H, CRN-H 64-7-1	37	1182	667	1849	300	200	54	305	1374	1679	389	382
CR-H, CRN-H 64-7	45	1188	709	1897	325	225	29	286	1378	1664	473	467
CR-H, CRN-H 64-8-2	45	1270	709	1979	325	225	29	286	1478	1764	478	471
CR-H, CRN-H 64-8-1	45	1270	709	1979	325	225	29	286	1478	1764	478	471

14. Motor data

2-pole motors for CR, CRI, CRN, 50 Hz

MG



TM031711

Motor P2 [kW]	Frame size	Standard voltage [V]	Full-load current I _{1/1} [A]	Power factor Cos φ _{1/1}	Efficiency class	Motor eff. η [%]	Starting current I _{start} [%]	Speed [rpm]
0.37 ²⁹⁾	71A	220-240Δ/380-415Y	1.74 / 1.00	0.80 - 0.70	IE3	73.8	490-530	2850-2880
0.55 ²⁹⁾	71B	220-240Δ/380-415Y	2.50 / 1.44	0.80 - 0.70	IE3	77.8	580-620	2830-2850
0.75 ²⁹⁾	80A	220-240Δ/380-415Y	3.30 / 1.90	0.81 - 0.71	IE3	80.7	580-620	2840-2870
1.1 ²⁹⁾	80C	220-240Δ/380-415Y	4.35 / 2.50	0.83 - 0.76	IE3	82.7	450-500	2840-2870
1.5 ²⁹⁾	90SD	220-240Δ/380-415Y	5.70 / 3.30	0.84 - 0.78	IE3	84.2	750-820	2890-2910
2.2 ²⁹⁾	90LE	380-415Δ	4.65	0.86 - 0.80	IE3	85.9	840-920	2890-2910
3 ²⁹⁾	100LC	380-415Δ	6.30	0.87 - 0.82	IE3	87.1	840-920	2900-2920
4 ³⁰⁾	112MC	380-415Δ	7.90	0.87	IE3	88.1	1000	2920-2940
5.5 ³⁰⁾	132SC	380-415Δ	11.00	0.87 - 0.82	IE3	89.2	1080-1180	2920-2940
7.5 ³⁰⁾	132SB	380-415Δ/660-690Y	14.4 - 14 / 8.3 - 8.1	0.88 - 0.82	IE3	90.1	780-910	2910-2920
11 ³⁰⁾	160MB	380-415Δ/660-690Y	20.8 - 19.8 / 12 - 11.8	0.88 - 0.84	IE3	91.2	660-780	2940-2950
15 ³⁰⁾	160MD	380-415Δ/660-690Y	28-26 / 16.2 - 15.6	0.89 - 0.87	IE3	91.9	660-780	2930-2950
18.5 ³⁰⁾	160LB	380-415Δ/660-690Y	34.5 - 32.5 / 20 - 18.8	0.89 - 0.85	IE3	92.4	830-980	2940-2950
22 ³⁰⁾	180MB	380-415Δ/660-690Y	39.5 / 22.8	0.90	IE3	92.7	830	2950

Innomotics



TM031710

30 ³⁰⁾	200L	380-420Δ/660-725Y	53-51 / 31 - 29.5	0.87	IE3	93.3	700	2955
37 ³⁰⁾	200L	380-420Δ/660-725Y	65-63 / 37.5 - 36	0.88	IE3	93.7	710	2955
45 ³⁰⁾	225M	380-420Δ/660-725Y	78-74 / 45-43	0.89	IE3	94.0	690	2960
55 ³⁰⁾	250M	380-420Δ/660-725Y	95-90 / 55-52	0.89	IE3	94.3	670	2975
75 ²⁹⁾	280S	380-420Δ/660-725Y	126 / 73	0.90	IE4	95.6	850	2978
90 ²⁹⁾	280M	380-420Δ/660-725Y	151 / 87	0.90	IE4	95.8	850	2980
110 ²⁹⁾	315S	380-420Δ/660-725Y	184 / 107	0.90	IE4	96.0	910	2988
132 ²⁹⁾	315M	380-420Δ/660-725Y	220 / 128	0.90	IE4	96.2	980	2988
160 ²⁹⁾	315L	380-420Δ/660-725Y	265 / 154	0.90	IE4	96.3	960	2986
200 ²⁹⁾	315L	380-420Δ/660-725Y	330 / 191	0.91	IE4	96.5	970	2986

²⁹⁾ Deep-groove ball bearings

³⁰⁾ Angular contact bearing mounted in drive end

4-pole motors for CR, CRI, CRN, 50 Hz

Motor P2 [kW]	Frame size	Standard voltage	Full-load current $I_{1/1}$ [A]	Power factor $\cos \phi_{1/1}$	Efficiency class	Motor eff. η [%]	Starting current I_{start} [%]	Speed [rpm]
		[V]						
MG								
								
0.25	71A	220-240Δ/380-415Y	1.48/0.85	0.75 - 0.65	-	61.5 - 68.5	400-440	1400-1420
0.37	71B	220-240Δ/380-415Y	1.90/1.10	0.77 - 0.67	-	66.0	400-440	1400-1420
0.55	80A	220-240Δ/380-415Y	2.60/1.50	0.79 - 0.70	-	70.0	430-470	1390-1410
0.75	90SC	220-240Δ/380-415Y	3.60/2.10	0.71 - 0.64	IE3	82.5	620-670	1455-1463
1.1	90SB	220-240Δ/380-415Y	4.85/2.80	0.71 - 0.64	IE3	84.1	820-900	1450-1460
1.5	90LC	220-240Δ/380-415Y	6.15 - 6.30/3.55 - 3.65	0.75 - 0.68	IE3	85.3	730-790	1450-1460
2.2	100LB	380-415Δ	4.90	0.79 - 0.73	IE3	86.7	600-660	1450
3	100LC	380-415Δ	6.90	0.82 - 0.76	IE3	87.7	700-770	1440-1450
4	112MC	380-415Δ	9.30	0.75 - 0.68	IE3	88.6	790-870	1460
5.5	132SB	380-415Δ/660-690Y	11.0 - 11.0/6.35 - 6.35	0.86 - 0.80	IE3	89.6	700-760	1460
7.5	132MB	380-415Δ/660-690Y	14.9 - 14.2/8.60 - 8.40	0.86 - 0.82	IE3	90.4	680-780	1460
11	160MA	380-415Δ/660-690Y	21.2 - 20.4/12.2 - 12.0	0.86 - 0.81	IE3	91.4	710-810	1470-1475
15	160LB	380-415Δ/660-690Y	29.0 - 28.0/16.8 - 16.4	0.86 - 0.82	IE3	92.1	760-870	1460-1470

TM031711

Innomotics								
								
18.5	180M	380-420Δ/660-725Y	35 - 33.5/20.5 - 19.5	0.82	IE3	92.6	720	1470
22	180L	380-420Δ/660-725Y	41 - 40.5/24 - 23.5	0.83	IE3	93.0	680	1470
30	200L	380-420Δ/660-725Y	55 - 54.0/32 - 31.5	0.84	IE3	93.6	730	1470
37	225S	380-420Δ/660-725Y	66 - 64.0/38.5 - 37.0	0.86	IE3	93.9	640	1478
45	225M	380-420Δ/660-725Y	80 - 77.0/46.5 - 44.5	0.86	IE3	94.2	660	1478
55	250M	380-420Δ/660-725Y	96 - 93.0/56 - 54.0	0.87	IE3	94.6	680	1482

TM031710

2-pole motors for CR, CRI, CRN, 60 Hz

MG



TM031711

Motor P2 [kW]	Frame size	Standard voltage [V]	Full-load current I _{1/1} [A]	Power factor Cos φ _{1/1}	Efficiency class	Motor eff. η [%]	Starting current I _{start} [%]	Speed [rpm]
0.37	71A	220-255Δ/380-440Y	1.50 - 1.44 / 0.87 - 0.83	0.85 - 0.76	IE3	73.4	550-650	3410-3470
0.55	71B	220-255Δ/380-440Y	2.15 - 2.05 / 1.25 - 1.20	0.85 - 0.76	IE3	76.8	500-600	3390-3460
0.75	80A	220-255Δ/380-440Y	2.95 - 2.75 / 1.70 - 1.60	0.86 - 0.77	IE3	77.0	600-740	3410-3470
1.1	80C	230-255Δ/400-440Y	4.10 - 4.00 / 2.38 - 2.30	0.86 - 0.80	IE3	84.0 - 84.0	440-500	3430-3470
1.5	90SD	230-277Δ/400-480Y	5.30 - 5.00 / 3.05 - 2.90	0.85 - 0.75	IE3	85.5	780-980	3480-3530
2.2	90LE	400-480Δ	4.30 - 4.00	0.88 - 0.80	IE3	86.5	730-1050	3480-3530
3	100LC	400-480Δ	6.00 - 5.40	0.90 - 0.84	IE3	88.5 - 88.5	910-1100	3490-3530
4	112MC	380-480Δ	7.80 - 6.80	0.91 - 0.82	IE3	88.5	1000-1470	3510-3540
5.5	132SC	380-480Δ	10.6 - 9.30	0.90 - 0.80	IE3	89.5	1020-1480	3510-3550
7.5	132SB	400-480Δ/690Y	13.8 - 12 / 8.1	0.88 - 0.82	IE3	90.2 - 90.2	750-1050	3500-3530
11	160MB	400-480Δ/690Y	20.1 - 17.2 / 11.6	0.88 - 0.83	IE3	91.0 - 91.0	640-890	3530-3550
15	160MD	400-480Δ/690Y	26.9 - 22.4 / 15.6	0.89 - 0.86	IE3	91.0 - 91.0	640-890	3530-3550
18.5	160LB	400-480Δ/690Y	33.2 - 28 / 16.6	0.88 - 0.84	IE3	91.7 - 91.7	760-1100	3530-3560
22	180MB	380-480Δ/660-690Y	40 - 32.5 / 23 - 22.2	0.91	IE3	91.7	650	3520-3560

Innomotics





TM031710

30 ³¹⁾	200L	440-480Δ	47-29	0.87	IE3	92.4	850	3560
37 ³¹⁾	200L	440-480Δ	57-35	0.88	IE3	93.0	760	3560
45 ³¹⁾	225M	440-480Δ	69-43	0.88	IE3	93.6	760	3570
55 ³¹⁾	250M	440-480Δ	83-52	0.89	IE3	93.6	730	3578
75 ³¹⁾	280S	440-480Δ	110	0.90	IE4	95.0	950	3580
90 ³¹⁾	280M	440-480Δ	132	0.90	IE4	95.4	1100	3582
110 ³¹⁾	315S	440-480Δ	161	0.90	IE4	95.4	1000	3588
132 ³¹⁾	315M	440-480Δ	192	0.90	IE4	95.8	1100	3590
160	315L	440-480Δ	235	0.90	IE4	95.8	1100	3588
200	315L	440-480Δ	285	0.91	IE4	96.2	1100	3588

³¹⁾ Innomotics motors operating at 440-480Δ voltage may be loaded with a service factor of 1.15.

4-pole motors for CR, CRI, CRN, 60 Hz

Motor P2 [kW]	Frame size	Standard voltage	Full-load current $I_{1/1}$ [A]	Power factor $\cos \varphi_{1/1}$	Efficiency class	Motor eff. η [%]	Starting current I_{start} [%]	Speed [rpm]	
		[V]							
MG									
									
									TM031711
0.25	71A	220-255Δ/380-440Y	1.21/0.70	0.80 - 0.69	-	73.4	400-470	1680-1720	
0.37	71B	220-255Δ/380-440Y	1.72/0.99	0.82 - 0.72	-	72.0	400-470	1680-1720	
0.55	80A	220-255Δ/380-440Y	2.40/1.40	0.83 - 0.75	-	75.5	390-470	1660-1710	
0.75	90SC	220-277Δ/380-480Y	3.45 - 3.40/2.00 - 1.95	0.76 - 0.61	IE3	83.9 - 83.9	570-720	1746-1768	
1.1	90SB	220-277Δ/380-480Y	4.50/2.60	0.76 - 0.60	IE3	86.5	710-910	1740-1770	
1.5	90LC	220-277Δ/380-480Y	5.90 - 5.65/3.40 - 3.25	0.78 - 0.65	IE3	86.5 - 86.5	660-930	1740-1770	
2.2	100LB	380-480Δ	4.70 - 4.30	0.83 - 0.71	IE3	89.5	590-760	1740-1760	
3	100LC	420-480Δ	6.49 - 6.20	0.81 - 0.73	IE3	89.5	710-880	1740-1760	
4	112MC	380-480Δ	8.60 - 8.30	0.79 - 0.64	IE3	89.5 - 89.5	770-910	1750-1770	
5.5	132SB	400-480Δ/690Y	10.7 - 9.40/6.20	0.86 - 0.79	IE3	91.7	710-850	1750-1770	
7.5	132MB	400-480Δ/690Y	14.3 - 12.5/8.25	0.86 - 0.80	IE3	91.7	650-890	1750-1770	
11.0	160MA	380-480Δ/660-690Y	20.8 - 17.8/12.0 - 11.8	0.90 - 0.81	IE3	92.4	650-970	1760-1780	
15.0	160LB	380-480Δ/660-690Y	29.0 - 24.2/16.6 - 16.4	0.88 - 0.81	IE3	93.0 - 93.0	650-980	1760-1770	

Innomotics									
									
									TM031710
18.5	180M	440-480Δ	30.5 - 19.0	0.81	IE3	93.6	870	1775	
22	180L	440-480Δ	36.5 - 23.5	0.81	IE3	93.6	770	1775	
30	200L	440-480Δ	48 - 31.5	0.83	IE3	94.1	880	1778	
37	225S	440-480Δ	58 - 36.5	0.85	IE3	94.5	750	1782	
45	225M	440-480Δ	70 - 44.0	0.85	IE3	95.0	770	1782	
55	250M	440-480Δ	84 - 53.0	0.86	IE3	95.6	760	1786	

15. Pumped liquids

The pumps are suitable for pumping thin, non-explosive liquids not containing solid particles or fibres. The liquid must not chemically attack the pump materials.

When pumping liquids with a density or viscosity higher than that of water, use oversize motors if required.

Whether a pump is suitable for a particular liquid depends on a number of factors of which the most important are the chloride content, pH value, temperature and content of chemicals and oils.

Note that aggressive liquids, such as seawater and some acids, may attack or dissolve the protective oxide film of the stainless steel, and cause corrosion.

CR, CRE, CRI, CRIE

CR, CRE, CRI, CRIE pumps are suitable for non-corrosive liquids.

Use CR, CRE, CRI, CRIE pumps for liquid transfer, circulation and pressure boosting of cold or hot clean water.

CRN, CRNE

CRN, CRNE pumps are suitable for industrial liquids.

Use CRN, CRNE pumps in systems where all parts in contact with the liquid must be made of high-grade stainless steel.

List of pumped liquids

A number of typical liquids are listed below.

Other pump versions may be applicable, but those stated in the list are considered to be the best choices.

The table is intended as a general guide only, and cannot replace actual testing of the pumped liquids and pump materials under specific working conditions.

Use the list with some caution. Factors such as those mentioned below may affect the chemical resistance of a specific pump version:

- concentration of the pumped liquid
- liquid temperature
- pressure.

Take safety precautions when pumping dangerous liquids.

Notes

D	It indicates liquid that is often used with additives.
E	The density or viscosity differ from that of water. Take this factor into account when calculating motor output and pump performance.
F	Pump selection depends on many factors. Contact Grundfos.
H	There is risk of crystallisation/precipitation in the shaft seal.
1	It indicates highly flammable liquid.
2	It indicates combustible liquid.
3	It indicates liquid that is insoluble in water.
4	It indicates liquid with low self-ignition point.

Pumped liquid	Chemical formula	Note	Liquid concentration and temperature	CR(E), CRI(E)	CRN(E)
Acetic acid	CH ₃ COOH	-	5 %, 20 °C	-	HQQE
Acetone	CH ₃ COCH ₃	1, F	100 %, 20 °C	-	HQQE
Alkaline degreasing agent		D, F	-	HQQE	-
Ammonium bicarbonate	NH ₄ HCO ₃	E	20 %, 30 °C	-	HQQE
Ammonium hydroxide	NH ₄ OH	-	20 %, 40 °C	HQQE	-
Aviation fuel		1, 3, 4, F	100 %, 20 °C	HQBV	-
Benzoic acid	C ₆ H ₅ COOH	H	0.5 %, 20 °C	-	HQQV
Boiler water		-	< 120 °C	HQQE	-
Calcareous water		F	120-180 °C	-	-
Calcium acetate (as coolant with inhibitor)	Ca(CH ₃ COO) ₂	-	< 90 °C	HQQE	-
Calcium acetate (as coolant with inhibitor)	Ca(CH ₃ COO) ₂	D, E	30 %, 50 °C	HQQE	-
Calcium hydroxide	Ca(OH) ₂	E	Saturated solution, +50 °C	HQQE	-
Chloride-containing water		F	< 30 °C, max. 500 ppm	-	HQQE
Chromic acid	H ₂ CrO ₄	H	1 %, 20 °C	-	HQQV
Citric acid	HOC(CH ₂ CO ₂ H) ₂ COOH	H	5 %, 40 °C	-	HQQE
Completely desalinated water (demineralised water)		-	120 °C	-	HQQE
Condensate		-	120 °C	HQQE	-
Copper sulphate	CuSO ₄	E	10 %, 50 °C	-	HQQE
Corn oil		D, E, 3	100 %, 80 °C	HQQV	-
Diesel oil		2, 3, 4, F	100 %, 20 °C	HQBV	-
Domestic hot water (drinking water)		-	< 120 °C	HQQE	-
Ethanol (ethyl alcohol)	C ₂ H ₅ OH	1, F	100 %, 20 °C	HQQE	-
Ethylene glycol	HOCH ₂ CH ₂ OH	D, E	50 %, 50 °C	HQQE	-
Formic acid	HCOOH	-	5 %, 20 °C	-	HQQE
Glycerine (glycerol)	OHCH ₂ CH(OH)CH ₂ OH	D, E	50 %, 50 °C	HQQE	-
Hydraulic oil (mineral)		E, 2, 3	100 %, 100 °C	HQQV	-
Hydraulic oil (synthetic)		E, 2, 3	100 %, 100 °C	HQQV	-
Isopropyl alcohol	CH ₃ CHOHCH ₃	1, F	100 %, 20 °C	HQQE	-
Lactic acid	CH ₃ CH(OH)COOH	E, H	10 %, 20 °C	-	HQQV
Linoleic acid	C ₁₇ H ₃₁ COOH	E, 3	100 %, 20 °C	HQQV	-
Methanol (methyl alcohol)	CH ₃ OH	1, F	100 %, 20 °C	HQQE	-
Motor oil		E, 2, 3	100 %, 80 °C	HQQV	-
Naphthalene	C ₁₀ H ₈	E, H	100 %, 80 °C	HQQV	-
Nitric acid	HNO ₃	F	1 %, 20 °C	-	HQQE
Oil-containing water		-	< 100 °C	HQQV	-
Olive oil		D, E, 3	100 %, 80 °C	HQQV	-
Oxalic acid	(COOH) ₂	H	1 %, 20 °C	-	HQQE
Ozone-containing water	(O ₃)	-	< 100 °C	-	HQQE

Pumped liquid	Chemical formula	Note	Liquid concentration and temperature	CR(E), CRI(E)	CRN(E)
Peanut oil		D, E, 3	100 %, 80 °C	HQQV	-
Petrol		1, 3, 4, F	100 %, 20 °C	HQBv	-
Phosphoric acid	H ₃ PO ₄	E	20 %, 20 °C	-	HQQE
Propanol	C ₃ H ₇ OH	1, F	100 %, 20 °C	HQQE	-
Propylene glycol	CH ₃ CH(OH)CH ₂ OH	D, E	50 %, 90 °C	HQQE	-
Potassium carbonate	K ₂ CO ₃	E	20 %, 50 °C	HQQE	-
Potassium formate (as coolant with inhibitor)	KOOCH	D, E	30 %, 50 °C	HQQE	-
Potassium hydroxide	KOH	E	20 %, 50 °C	-	HQQE
Potassium permanganate	KMnO ₄	-	5 %, 20 °C	-	HQQE
Rape seed oil		D, E, 3	100 %, 80 °C	HQQV	-
Salicylic acid	C ₆ H ₄ (OH)COOH	H	0.1 %, 20 °C	-	HQQE
Silicone oil		E, 3	100 %	HQQV	-
Sodium bicarbonate	NaHCO ₃	E	10 %, 60 °C	-	HQQE
Sodium chloride (as coolant)	NaCl	D, E	30 %, < 5 °C, pH > 8	HQQE	-
Sodium hydroxide	NaOH	E	20 %, 50 °C	-	HQQE
Sodium hypochlorite	NaOCl	F	0.1 %, 20 °C	-	HQQV
Sodium nitrate	NaNO ₃	E	10 %, 60 °C	-	HQQE
Sodium phosphate	Na ₃ PO ₄	E, H	10 %, 60 °C	-	HQQE
Sodium sulphate	Na ₂ SO ₄	E, H	10 %, 60 °C	-	HQQE
Softened water		-	< 120 °C	-	HQQE
Soya oil		D, E, 3	100 %, 80 °C	HQQV	-
Sulphuric acid	H ₂ SO ₄	F	1 %, 20 °C	-	HQQV
Sulphurous acid	H ₂ SO ₃	-	1 %, 20 °C	-	HQQE
Unsalted swimming-pool water		-	Approx. 2 ppm free chlorine (Cl ₂)	HQQE	-

16. Grundfos Product Center

Online search and sizing tool to help you make the right choice.

From the international view, you can select your specific country to view the product range available to you.

International view: <https://product-selection.grundfos.com>

All the information you need in one place

Performance curves, technical specifications, pictures, dimensional drawings, motor curves, wiring diagrams, spare parts, service kits, 3D drawings, documents, system parts. The Product Center displays any recent and saved items - including complete projects - right on the main page.

Downloads

On the product pages, you can download installation and operating instructions, data booklets, service instructions, etc., in PDF format.

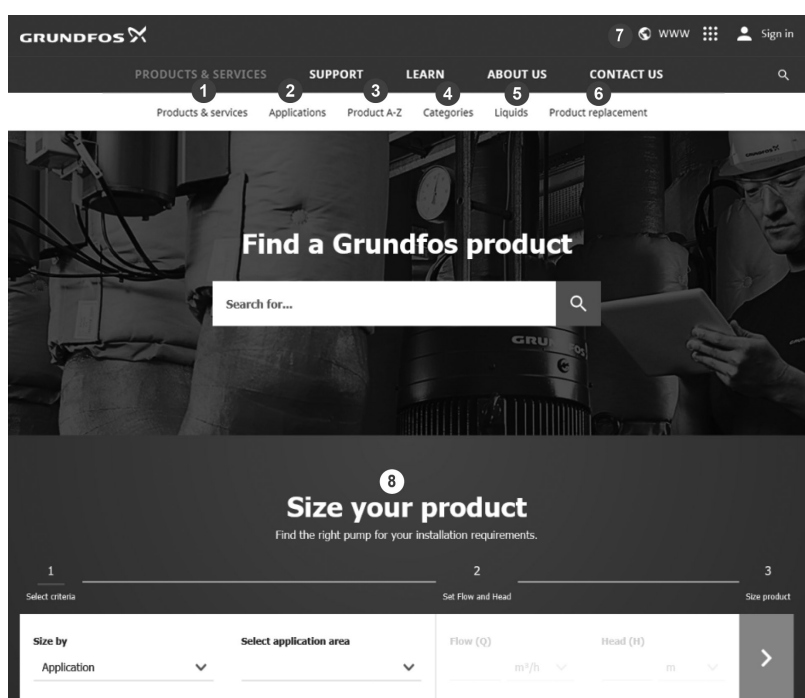

When you select your country, you will see the menus below. Note that some menus may not be available depending on the country.

Example: <https://product-selection.grundfos.com/uk>

Pos.	Description
1	Products & services enables you to find products and documents by typing a product number or name into the search field.
2	Applications enables you to choose an application to see how Grundfos can help you design and optimise your system.
3	Products A-Z enables you to look through a list of all the Grundfos products.
4	Categories enables you to look for a product category.
5	Liquids enables you to find pumps designed for aggressive, flammable or other special liquids.
6	Product replacement enables you to find a suitable replacement.
7	WWW enables you to select the country, which changes the language, the available product range and the structure of the website.
8	Sizing enables you to size a product based on your application and operating conditions.

Grundfos GO

Mobile solution for professionals on the GO!

Grundfos GO is the mobile tool box for professional users on the go. It is the most comprehensive platform for mobile pump control and pump selection, including

sizing, replacement and documentation. It offers intuitive, handheld assistance and access to Grundfos online tools, and it saves valuable time for reporting and data collection.

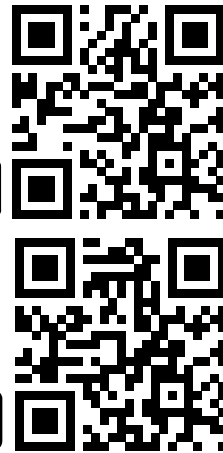

17. Document quality feedback

To provide feedback about this document, scan the QR code using your phone's camera or a QR code app.



FEEDBACK96486346

[Click here to submit your feedback](#)

96486346 01.2025

ECM: 1409958

GRUNDFOS Holding A/S
Poul Due Jensens Vej 7
DK-8850 Bjerringbro
Tel: +45 87 50 14 00
www.grundfos.com

GRUNDFOS 