

# Service instructions



CRN 8 model B

CRT 8 model A

50/60 Hz

1/3~

## Table of contents

<b>1.</b>	<b>Type identification .....</b>	<b>2</b>
1.1	Nameplate CR, CRN, CRT .....	2
1.2	Type key .....	3
1.3	Codes used.....	3
<b>2.</b>	<b>Torques and lubricants .....</b>	<b>4</b>
<b>3.</b>	<b>Service tools .....</b>	<b>5</b>
3.1	Special tools .....	5
3.2	Standard tools.....	5
3.3	Torque tools.....	5
<b>4.</b>	<b>Shaft seals.....</b>	<b>6</b>
<b>5.</b>	<b>Dismantling and assembly .....</b>	<b>7</b>
5.1	Dismantling .....	7
5.2	Assembly .....	8
<b>6.</b>	<b>Order of assembly for chambers and impellers .....</b>	<b>10</b>
6.1	CRN 8 .....	10
6.2	CRT 8 .....	11

# 1. Type identification

This section shows the type key, the nameplate and the codes that can appear in the variant code.

**Note:** As codes can be combined, a code position may contain more than one code (letter).

## 1.1 Nameplate CR, CRN, CRT

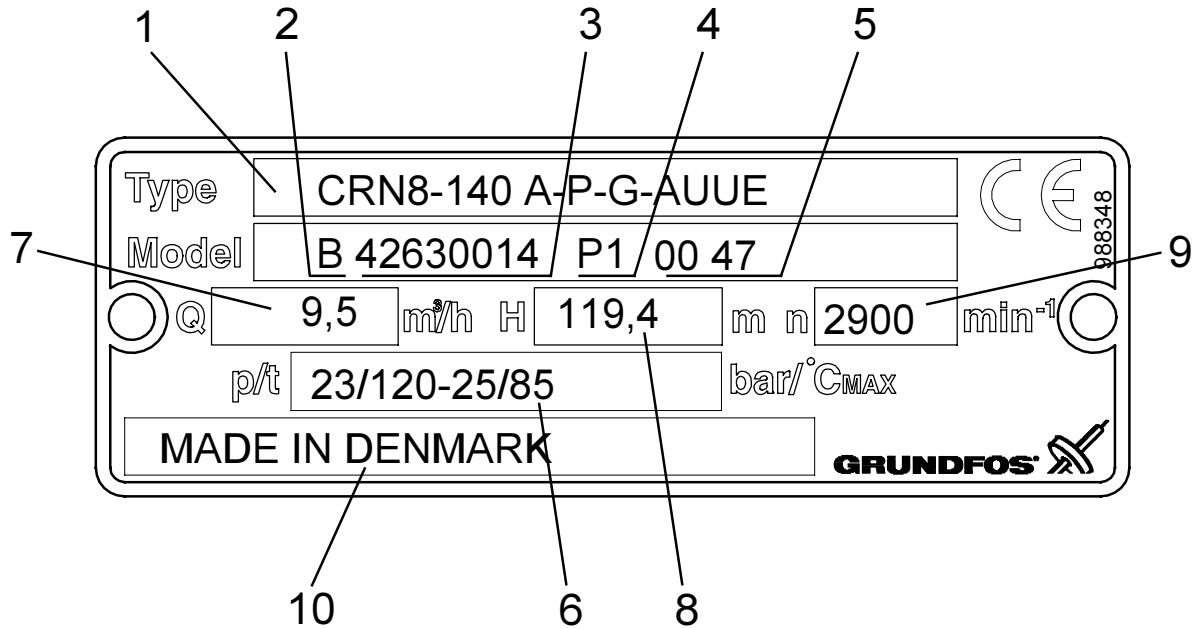

TM00 3164 4800

Pos.	Description	Pos.	Description
1	Type designation	6	Maximum pressure and temperature
2	Model	7	Rated flow rate
3	Product number	8	Head at rated flow rate
4	Place of production	9	Speed
5	Production year and week	10	Country of production

## 1.2 Type key

Example	CRN	8 -	20	/1	X-	X-	X-	XXXX
Type range								
Rated flow rate in m <sup>3</sup> /h								
Number of stages x 10								
Number of impellers (is only used if the pump has fewer impellers than chambers)								
Code for pump version a)								
Code for pipe connection b)								
Code for materials (excluding plastic and rubber parts) c)								
Code for shaft seal d)								

## 1.3 Codes used

Note	Code	Description
a	A	Basic version
	S	Pump without staybolts
	T	Oversize motor, two flange sizes bigger
	U	NEMA version
b	C	Clamp coupling
	F	DIN flange
	G	ANSI flange
	J	JIS flange
	O	Union
	P	PJE coupling
c	G	Stainless steel parts in DIN W.-Nr. 1.4401
	T	Stainless steel parts replaced by titanium parts
d	BUBE/V	Rubber bellows seal; rotating face: tungsten carbide; stationary seat: synthetic resin-impregnated carbon; O-rings: E=EPDM, V=FKM
	AUUE/V	O-ring seal; rotating face: tungsten carbide; stationary seat: tungsten carbide; O-rings: E=EPDM, V=FKM

## 2. Torques and lubricants

This section shows the screws and nuts that must be tightened to a certain torque and the lubricants to be used.

Pos.	Description	Dim.	Torque [Nm]	Lubricant
9	Hexagon socket head screw	M6 x 20	13	Thread-eze
		M8 x 25	31	
		M10 x 25	62	
18	Air vent screw		5/20	Bonderlube
25	Drain plug		10/20	Bonderlube
28	Hexagon head screw	M6 x 20	10	Thread-eze
		M6 x 25		
		M8 x 20	12	
		M8 x 25		
		M12 x 30	40	
28.a	Hexagon head screw	M12 x 25	40	Thread-eze
		M16 x 45	80	
36	Nut	M16	100	Thread-eze
36.a	Nut	M16	80	Thread-eze
67	Nut	M12	40	Bonderlube
103	Seal ring, stationary			Silicone oil
104	Seal ring, rotating			
127	Hexagon socket head screw	M16	100	Thread-eze
134				

Thread-Eze, part no. SV9997 (0,5 l).

Bonderlube, part no. SV9995 (1 l).

Silicone oil, part no. SV0862 (1 l.)

### 3. Service tools

The following drawings and tables show special, standard and torque tools for pump service.

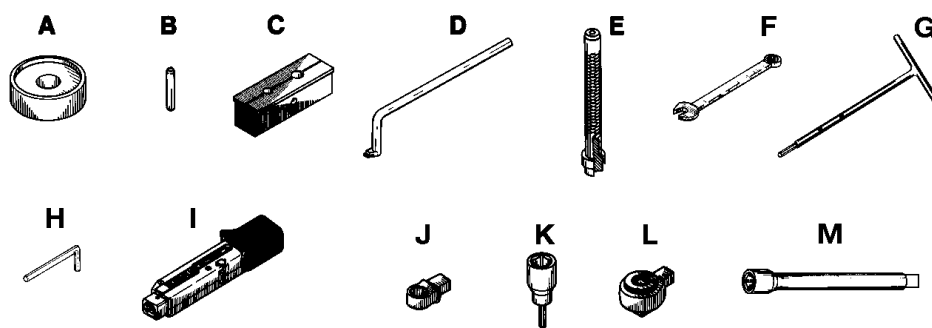

TM00 2462 1193

#### 3.1 Special tools

Pos.	Description	For pos.	Suppl. information	Part no.
A	Shaft holder for dismantling			SV0287
B	Punch for removing the shaft	51		SV0286
C	Shaft holder for assembly			SV0040
D	Puller for neck ring	45		SV0239
E	Punch for removing the pump head cover	77		SV0252

#### 3.2 Standard tools

Pos.	Description	For pos.	Suppl. information	Part no.
F	Ring/open-end spanner	28	M6 - 10 mm	SV0083
		28	M8 - 13 mm	SV0055
		28-28.a-67	M12 - 19 mm	SV0054
		18-25-28.a-36-36.a	24 mm	SV0122
G	Tee key	9	M6 - 5 mm	SV0124
			M8 - 6 mm	SV0050
			M10 - 8 mm	SV0051
H	Hexagon socket head screw key	127-134	M16 - 14 mm	SV0393

#### 3.3 Torque tools

Pos.	Description	For pos.	Suppl. information	Part no.	
I	Torque wrench	H-I-J	4-20 Nm	9 x 12	SV0292
			20-100 Nm	9 x 12	SV0269
			40-200 Nm	14 x 18	SV0400
J	Ring spanner	28-I	M6 - 10 mm	9 x 12	SV0310
		28-I	M8 - 13 mm	9 x 12	SV0294
		28-28.a-67-I	M12 - 19 mm	9 x 12	SV0271
		36-36.a-I	M16 - 24 mm	14 x 18	SV0524
K	Socket driver for hexagon socket head screws	9-I-L	M6 - 5 mm	1/2" x 1/2"	SV0296
			M8 - 6 mm	1/2" x 1/2"	SV0297
			M10 - 8 mm	1/2" x 1/2"	SV0298
		127-134	M16 - 14 mm	1/2" x 1/2"	SV0394
L	Ratchet insert tool	I-K	9 x 12 -> 1/2" x 1/2"	SV0295	
M	Extension bar	L-137-134	1/2" x 1/2" x 10	SV0395	

## 4. Shaft seals

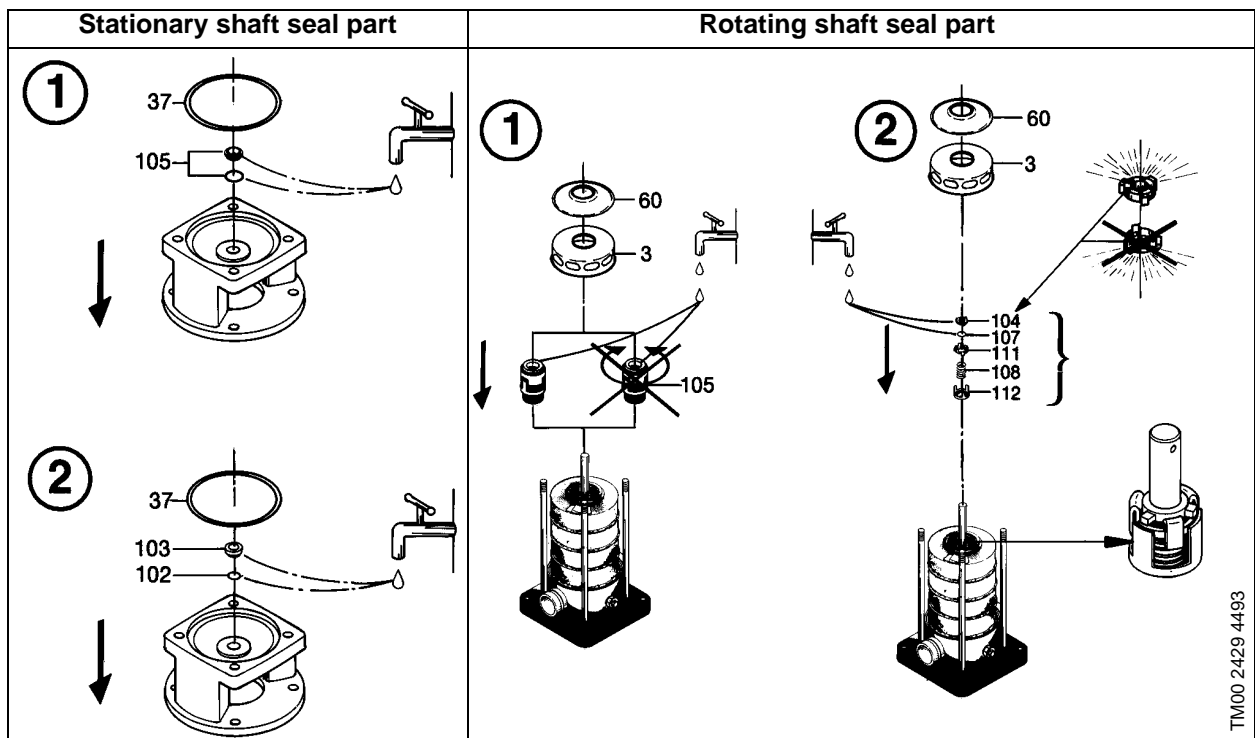
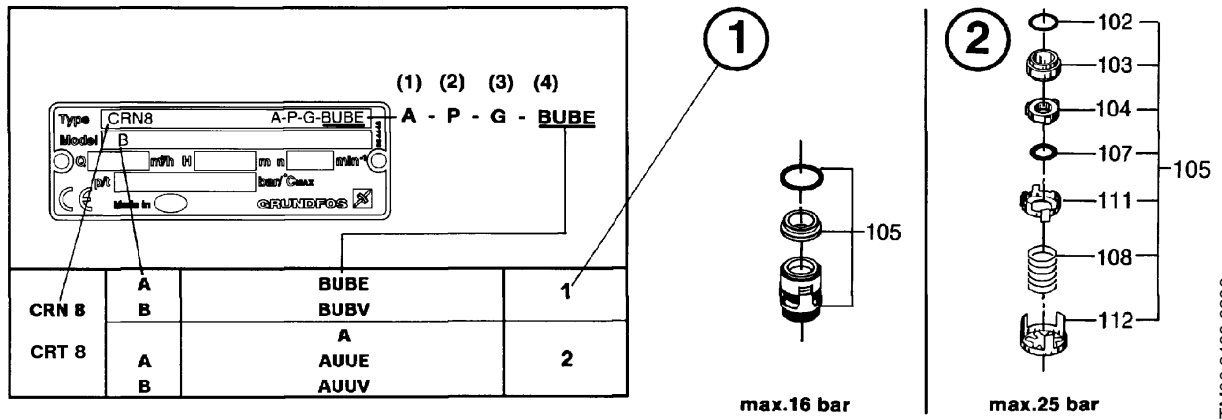

## 5. Dismantling and assembly

The GRUNDFOS centrifugal pumps, types CRN 8/CRT 8, are multistage in-line pumps.

If it is necessary to dismantle the pump, either because it is choked or damaged, please follow the instructions below.

Position numbers, see “Parts list” and section [3. Service tools](#).

### 5.1 Dismantling

Slacken the screws pos. 7a and remove them together with the coupling guards pos. 7. Remove the hexagon socket head screws, pos. 9, the coupling, pos. 8, and the shaft pin, pos. 10.

Slacken and remove the hexagon head screws, pos. 28. The motor is now free and can be lifted off.

Remove the nuts, pos. 36, and the washers, pos. 66a.

CRN 8 S: Remove the nuts, pos. 128, the hexagon socket head screws, pos. 127, and the washers, pos. 129.

Loosen the pump head, pos. 2, with a light blow on the edge. Remove the pump head (with pump head cover, pos. 77, stationary shaft seal part and disc spring, pos. 60).

Pull the rotating shaft seal part off the shaft, see section [4. Shaft seals](#).

*The seal ring must not be exposed to blows or knocks.*

CRN 8 S: Remove the hexagon socket head screws, pos. 134, and the washers, pos. 135.

Remove the outer sleeve, pos. 55, and the top chamber, pos. 3.

Loosen the chamber stack with a light blow of a rubber mallet and lift it out of the inlet part, pos. 44.

CRT 8: Remove the split pin, pos. 67.a.

Hold the shaft by means of a screwdriver inserted in the shaft pin hole while the nut, pos. 67, is slackened. Remove the nut, the washer, pos. 66 (not included in CRT), and the spacing pipe, pos. 64c.

Place the shaft holder, pos. A, in a vice and tighten it. Place the chamber stack in the shaft holder with the threaded shaft end pointing upwards.

*Make sure that the chamber is positioned in the recess of the shaft holder, pos. A, and that the shaft can pass freely through and underneath the shaft holder.*

Screw the punch for dismantling, pos. B, home on the threaded shaft end.

The first chamber to be removed is always a chamber with bearing ring, pos. 4a. See also section [6. Order of assembly for chambers and impellers](#).

Drive the punch down through the impeller hub by means of a hammer. Remove the free parts from the shaft: Impeller, spacing pipe, chamber, bearing ring and spacing pipe. Repeat the procedure until the shaft passes through the shaft holder, pos. A.

*Take care not to damage the shaft when it is driven free of the last impeller and the spacer for shaft seal, pos. 61.*

Remove the punch, pos. B, from the threaded shaft end.

If the stop ring, pos. 62, is damaged, push it out of the recess and pull it free of the spline (towards the threaded shaft end).

#### Pump head

Press the stationary shaft seal part out of the pump head by means of a nylon punch or a similar tool, see section [4. Shaft seals](#), and remove the gasket, pos. 37.

*The stationary seal ring must not be exposed to blows or knocks.*

Remove the air vent screw, pos. 18, (right-hand thread) with O-ring, pos. 100.

Loosen the pump head cover complete, pos. 77, from the pump head by knocking the socket, in which the air vent screw was fitted, downwards by means of a rubber mallet.

Drive the cover out of the pump head by means of the punch, pos. E, which is inserted in the socket. Remove the pump head cover.

### Neck ring

Free the neck ring, pos. 45, by pushing up the neck ring retainer, pos. 65, with the puller, pos. D.

### Base

Push the inlet part, pos. 44, and the guide plate, pos. 6d, free of the base, pos. 6, using two screwdrivers. Remove the gasket, pos. 37, from the base.

### Outer sleeve

CRN 8 S: Remove the retaining rings, pos. 126 and 133, and the clamping plates, pos. 125 and 132.

## 5.2 Assembly

Before assembly, clean and check all parts.

Parts which are defective or do not comply with the measurements mentioned below due to wear should be replaced by new parts.

Nut for shaft, gaskets and O-rings should always be replaced when the pump is overhauled.

### Bearing

The maximum permissible difference between the diameters of the rotating bearing ring, pos. 47a, and the stationary bearing ring in the chamber, pos. 4a, is 0.4 mm.

### Pump head

Moisten the O-rings, pos. 78 and 98, with water and fit them to the collar and the socket of the pump head cover, pos. 77.

Push the pump head cover into the pump head.

Make sure that the pump head cover is pressed home in the pump head.

Fit the O-ring, pos. 100, to the air vent screw, pos. 18, and fit the screw (right-hand thread) into the socket of the pump head cover.

Moisten the recess of the pump head cover and the stationary shaft seal part with water.

Press the stationary shaft seal part into the recess of the pump head using fingers only, see section [4. Shaft seals](#).

*The stationary seal ring must not be exposed to blows or knocks.*

Moisten the gasket, pos. 37, with water and place it in the recess of the pump head.

### Impeller

The impeller must fit into the neck ring. If the tolerance (clearance) between neck ring and impeller is too big, replace the worn part.

### Neck ring

Place the neck ring, pos. 45, on the chamber/inlet part. Then place the neck ring retainer, pos. 65, on the neck ring and press it until it engages with the chamber/inlet part.

It must be possible to move the neck ring freely (sideways) between the retainer and the chamber/inlet part.

**Note:** No neck ring is fitted in the chamber, pos. 3a.

### Base

Fit the guide plate, pos. 6d, the gasket, pos. 37, and the inlet part, pos. 44, in the base. Make sure that the projection on the upper side of the guide plate engages with the inlet part.

### Outer sleeve

CRN 8 S: Fit the clamping plates, pos. 125 and 132, to the outer sleeve. The chamfer must point towards the retaining ring. Fit the retaining rings, pos. 126 and 133, into the recesses of the outer sleeve.



Place the shaft holder, pos. C, in the vice. Place the shaft, pos. 51, in the shaft holder and tighten the vice. The threaded shaft end must be uppermost and the opposite end must be flush with the lower edge of the shaft holder.

Fit the stop ring, pos. 62, in the recess of the shaft.

Fit the spacer for shaft seal, pos. 61, to the shaft with the driving dogs pointing towards the vice.

Continue the assembly up to the nut, pos. 67, see section [6. Order of assembly for chambers and impellers](#).

CRT 8: The nut pos. 67 is locked by a split pin pos. 67.a instead of a washer pos. 66.

Lubricate the nut, pos. 67, with BONDERLUBE. Fit the nut and tighten to the torque stated in section [2. Torques and lubricants](#).

Slacken the vice and lift the chamber stack off the shaft holder.

Fit the chamber stack with the smooth shaft end pointing upwards and press it down so that it engages with the inlet part in the base.

Fit the outer sleeve, pos. 55, to the base. Do not forget the gasket, pos. 37.

CRN 8 S: Lubricate and fit the hexagon socket head screws, pos. 134, and the washers, pos. 135. Tighten the screws diagonally to the torque stated in section [2. Torques and lubricants](#).

Fit the rotating shaft seal part, see section [4. Shaft seals](#).

Moisten the rubber parts with water before they are fitted.

*Make sure that the rubber parts are not damaged on the shaft pin hole and that the seal rings are not exposed to blows or knocks.*

Check that the spacer for shaft seals (pos. 61) engage when the spring is compressed. The spring will then press the seal ring upwards to a neutral spring position.

Fit the top chamber, pos. 3, and the disc spring, pos. 60.

Before fitting the pump head, pos. 2, check that the gasket, pos. 37, and the stationary shaft seal part are positioned correctly.

In the case of shaft seals with stationary and rotating seal rings of tungsten carbide, lubricate the seal faces with silicone oil. Part number, see section [2. Torques and lubricants](#).

*Lubricate the seal faces only.*

Fit the pump head to the chamber stack with the air vent screw, pos. 18, in the required position.

CRN 8 S: Lubricate and fit the hexagon socket head screws, pos. 127, the washers, pos. 129, and the nuts, pos. 128. Tighten the nuts diagonally to the torque stated in section [2. Torques and lubricants](#).

Lubricate the threads of the staybolts. Replace the washers, pos. 66a, and the nuts, pos. 36, and tighten diagonally to the torque stated in section [2. Torques and lubricants](#).

Fit the motor and turn it to the required terminal box position. Lubricate the screws, pos. 28. Fit the screws and tighten diagonally to the correct torque.

Fit the shaft pin pos. 10 in the shaft pin hole. Fit the coupling, pos. 8. Lubricate the hexagon socket head screws, pos. 9. Fit the hexagon socket head screws, tighten and leave loose.

Check that the gaps either side of the coupling halves are equal and that the chamber stack is in its bottom position.

Raise the chamber stack 1-2 mm from its bottom position by means of a large screwdriver or a similar tool inserted underneath the coupling.

Tighten the hexagon socket head screws two and two (one side at a time), see section [2. Torques and lubricants](#).

Check that the gaps either side of the coupling halves are equal and check the pump by turning the coupling. If the pump is tight or it cannot be rotated, a further adjustment should be carried out.

Fit the two coupling guards pos. 7 and fasten them with the screws pos. 7a.

The pump is now assembled. Check the head and flow and compare the results with the test specification no. BM42A001.

## 6. Order of assembly for chambers and impellers

1. Determine pump type (CRN 8 or CRT 8) and stage variant. Find the pump in the relevant stage survey table.
2. Find the components of each stage in the symbol survey.

### 6.1 CRN 8

#### Stage survey

20/1	20	30	40	50	60	80	100	120	140	160	180	200	
▲	▲	▲	▲	▲	▲	▲	▲	▲	▲	▲	▲	▲	1
●	○	★	★	★	★	★	★	★	★	★	★	★	2
○	○	○	★	★	★	★	★	★	★	★	★	★	3
		○	○	★	★	★	★	★	★	★	★	★	4
			○	○	★	★	★	★	★	★	★	★	5
				○	○	★	★	★	★	★	★	★	6
					○	○	★	★	★	★	★	★	7
						○	★	★	★	★	★	★	8
							○	★	★	★	★	★	9
								○	★	★	★	★	10
									○	★	★	★	11
										○	★	★	12
											○	★	13
												○	14
													15
													16
													17
													18
													19
													20
													21

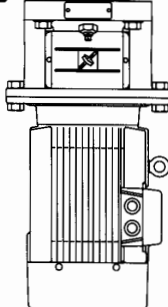

TM00 002344 3296

Position numbers marked ▲ are not used for CRN 8-20/1 and CRT 8-20/1.

#### Symbol survey

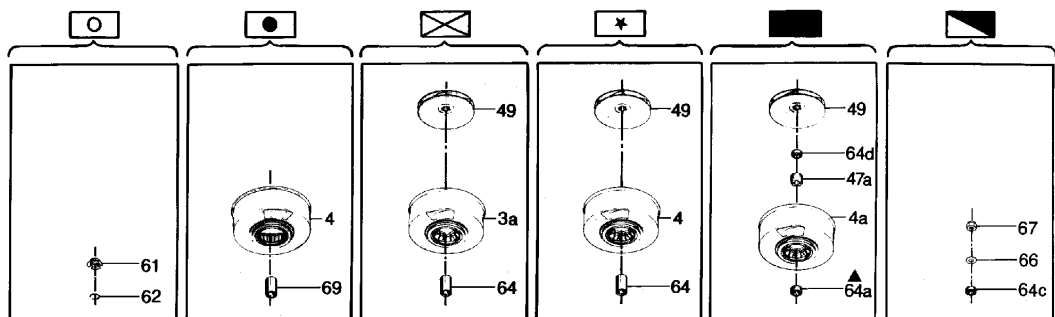

TM00 2343 1498

## 6.2 CRT 8

### Stage survey

	20/1	20	* 40/3	40	* 60/5	60	* 100/8	100	* 140/12	140	* 180/14	180	200	
	●	⊗	★	★	★	★	★	★	★	★	★	★	★	1
			★	★	★	★	★	★	★	★	★	★	★	2
			●	⊗	★	★	★	★	★	★	★	★	★	3
					★	★	■	★	★	★	■	★	★	4
				●	⊗	★	■	★	★	★	★	★	★	5
					★	★	★	★	★	★	★	■	★	6
					★	★	■	★	★	★	★	★	★	7
					★	★	■	★	★	★	★	■	★	8
					●	★	★	★	★	★	★	★	■	9
					●	⊗	★	■	★	★	★	★	★	10
						★	★	★	★	★	★	★	★	11
						★	★	■	★	★	★	★	★	12
						●	★	★	★	★	★	★	★	13
						●	⊗	★	■	★	★	★	★	14
								★	★	★	★	★	★	15
								★	★	■	★	★	★	16
								●	★	★	★	★	★	17
								●	⊗	★	■	★	★	18
												★	★	19
												⊗	★	20

Note:

\* indicates that ...

- the type designation for the pump has been changed
- the pump has one or two extra empty chambers
- shaft, outer sleeve and staybolts are correspondingly longer.

### Symbol survey

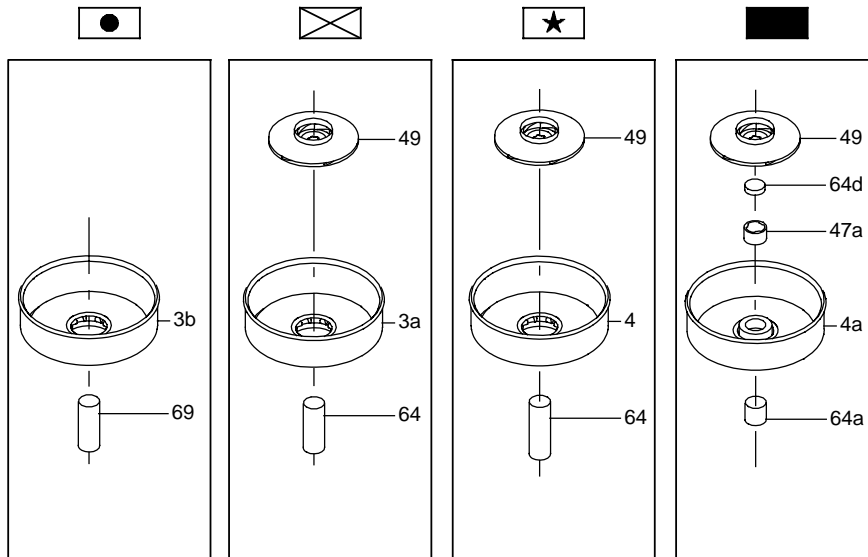

TM02 4716 1502