

Transforming water, together with Grundfos solutions

We help you transform with more sustainable,
intelligent, and optimised solutions for water supply
and wastewater challenges.



GRUNDFOS 

Possibility in every drop

Collaborating towards a sustainable water future

Meeting growing demand for clean, safe water means transforming how we manage drinking water, wastewater, and irrigation. But the journey towards a sustainable water future is complex and can take many turns. Working together with multiple stakeholders within water utility and groundwater & irrigation we design intelligent and sustainable pumping solutions that optimise water management without compromising on system reliability or uptime.

By 2050, global population is expected to exceed 9 billion, with about 75% living in cities. At the same time, the impacts of climate change, such as droughts, flooding, and extreme climate events, are depleting groundwater and putting pressure on water infrastructure.

According to the UN, every country will experience the drastic effects of climate change, and more and more countries are experiencing water scarcity. That's why the UN created Sustainable Development Goal (SDG) 6 "Ensure access to water and sanitation for all" and SDG 13 "Taking urgent action to combat climate change and its impacts".

At Grundfos, we're committed to working towards SDGs 6 and 13 as a fundamental part of our business strategy. The world needs more energy-efficient clean drinking water, irrigation, and wastewater solutions, and we have the technology to make a significant contribution to solving the world's climate challenges including sustainable water access and use.

Offering more than 75 years of trusted water expertise and a complete range of intelligent solutions, we are working to take complexity out of water management – from intelligent energy efficient pumps to digital solutions – including end-to-end support.

Moving forward through digital innovation

At Grundfos, we never settle for the status quo – we challenge it through innovation, in everything we do. Combining our engineering and water expertise with the knowledge of our customers, we deliver intelligent solutions enabling our customers to meet their goals and obligations, while delivering reliability and sustainability to their business. But intelligent solutions are worth nothing if they are not simple and robust, so we put these qualities at the centre of our development – to ensure our solutions perform under the most challenging conditions.



A full portfolio of reliable, sustainable solutions

To best serve our municipal water utility and groundwater & irrigation customers, we offer a full range of intelligent solutions covering the entire water cycle. We provide leading technologies, which are both energy-efficient and compliant, taking the view that sustainable water solutions should be both reliable and affordable.

End-to-end offerings

From design to delivery and service, working with Grundfos means you can take advantage of our comprehensive engineering skills and project management expertise, including local support, long-standing experience, and fully integrated intelligent solutions.

We invest substantially in research and development of sustainable solutions. Our goal is to help you realise ultimate system efficiency and meet your targets through innovation, high quality, and reliability – and to pave the way to a new water future with you.

Count on us to tick all the boxes

New projects and major refurbishments often require customised products and expedited delivery times. We are a trusted partner for consultants, contractors and water utilities looking for security, compliance, and know-how for their water supply, wastewater, groundwater, or irrigation pumping solution from a full-line supplier.

Meeting and exceeding international quality standards

Grundfos guarantees unsurpassed product quality using stress, vibration, product lifetime, witness and environmental impact testing to meet or even surpass international standards. In addition, we offer Acceptance Grade testing up to Grade 1 at our own facilities, in accordance with ISO 9906:2012 and ANSI/HI 11.6:2017 standards.

Product information at your fingertips

The Grundfos Product Center is a free digital product catalogue and sizing tool, offering one-point access for all product information including pump curves, CAD drawings, and service manuals. Available online and as a desktop (offline) edition, Grundfos Product Center is optimised for viewing on your smartphone or tablet.

See: product-selection.grundfos.com



Grundfos Connect – Remote monitoring at anytime, anywhere

Grundfos Connect is an efficient and cost-effective alternative to complex and costly SCADA systems or similar and opens the door for future AI and cloud-based algorithm technologies for operation and optimisation. It reduces the need for onsite inspections, and, in the event of an alarm or warning, the relevant people are notified directly.

See: product-selection.grundfos.com/products/grundfos-connect

Global reach, local service

Thanks to our global presence, we can deliver solutions to the outermost parts of the world and provide locally adapted expertise and service. We are there throughout the entire process, from selection and installation to operation and replacement, so you can work smarter while we work harder, no matter your geographical location.

Service Agreements tailored to your requirements

The Grundfos Service Agreement is the basis of our service offerings to you. It ensures a level of preventive service that keeps the pump operating within its design parameters, reducing the risk of downtime. This is done through scheduled onsite checks. Pump performance is maintained through regular maintenance and keeping a stock of recommended spare parts onsite.

We offer a range of service options and add-ons and tailor the service agreement to your requirements.

- **Remote management:** Digital cloud-based pump control and performance monitoring services
- **Preventive maintenance:** Agreement on maintenance and spare parts
- **Energy optimisation:** Identify potential energy savings with a pump audit or energy check
- **Breakdown repair:** Agreement on terms for on-site or workshop repairs
- **Installation:** By experienced personnel freeing up time for other tasks
- **Commissioning:** Making sure your pump installation is ready to run
- **Laser alignment:** Reducing pump wear and optimising efficiency
- **Scheduled service check:** Planned maintenance visits
- **Service level upgrade:** Agreement on response time and performance

Fast and flexible delivery of spare parts

Grundfos spare parts are made of high quality original Grundfos components. Fast and flexible delivery keeps your system optimised and minimises the risk of future breakdowns. With every solution, we guarantee minimum 10 years' delivery of service parts, or a replacement pump on discontinued pumps.

Grundfos spare parts are available as single or bulk parts for exchange as needed, and as part of service kits, tailored for service and repair for a particular pump or system.

Our recommended spare parts consist of components for a specific pump that we know from experience are likely to need replacement after the first two years or five years of operation.

Grundfos Pump Audit

Grundfos offers a comprehensive auditing service identifying potential energy savings in any pumping system.

- Our diagnostic tool identifies excessive energy consumption and proposes changes for increased system efficiency
- The recommendations cover the size and number of pumps, the viability of frequency control, and suitable motor protection

Trusted, purpose-driven company

- We have a family-driven heritage of +75 years in pumping applications
- Your leading partner of robust and high efficiency pump solutions and service support
- Our solutions are tested by leading experts to secure you peace of mind
- Our people and their expertise can make the difference based on many years' experiences within your business area

Global reach, local service

- Your global partner that delivers solutions to all parts of the world
- Together we can work smarter by supporting you throughout the entire process
- We provide locally adapted expertise and service to fit your local needs
- We offer a wide availability of trusted products and services

Innovation & digital pioneer

- We are constantly challenging status quo with pioneering innovation
- We partner with eco-system stakeholders to leverage combined expertise and holistic solutions together
- We deliver connected, digital solutions that reduce your manhours and costs
- Simplicity and robustness are key drivers when developing products for you

Full water cycle portfolio

- We offer a full range of sustainable, energy-efficient solutions for you
- Together we can simplify your operational workflow with our end-to-end solutions
- Our reliable portfolio makes us your trusted choice
- We provide leading future-proof and compliant solutions for you

Transforming into a sustainable water future

With a family-driven heritage, we are known throughout the world for providing robust pump solutions and extraordinary service support. When you invest in a Grundfos solution, you invest in reliability, as our solutions have been tested by some of the industry's best engineers to ensure performance as expected and provide total peace of mind. We help

you transform into more sustainable, intelligent, and optimised water management solutions – without ever compromising on system reliability and up-time. At Grundfos, we discover new opportunities and offer innovative and reliable pump solutions and services to help transform and manage our water systems from source to tap, together.

Towards a more sustainable future for water utilities

On top of various pressures caused by environmental changes and water scarcity, many municipal water utilities are challenged with issues caused by aging infrastructure. Aging pipe systems are causing a rise in water leakage and non-revenue water, which are draining utilities' budgets.

Meanwhile regulations in many regions around the discharged treated water quality, household connectivity and safety are becoming more stringent, while water tariffs are also becoming regulated and politically influenced.

One approach to solving these challenges is through our sustainable, intelligent, and optimised solutions across the water supply or wastewater network. The

vision is to enable you to transport and process water more efficiently, while avoiding downtime and saving time and money.

Digital solutions hold the key

Advancements in digitalization have helped water utilities connect their systems, harness data, and transform it into valuable insights. Smart sensors, advanced AI and analytics enable autonomous water networks – networks that can predict demand, overflows, leakage, etc. – and adjust operations accordingly. With more than 75 years of proven water solutions, Grundfos is your reliable water management partner that prepares you for tomorrow by helping you transform with more sustainable, intelligent, and optimised water management solutions.



Water supply expertise

From the raw water intake to the treatment regime and onwards through the distribution network to the consumer, a water supply system must be fully integrated. We ensure that pumps, controls, dosing and disinfection solutions and pressure management work together for a reliable, energy efficient water supply, with a minimum of non-revenue water.

- **Raw water intake**
We offer a reliable, energy-optimised, and cost-effective submersible pumping solution for borehole installations.
- **Surface water intake**
We offer a full line of pump solutions for river, lake, or marine extraction.
- **Drinking water treatment**
We offer solutions for the water treatment processes to help your treatment plant securing the right water quality.
- **Water distribution**
We deliver water distribution with the right pressure – so you can reduce pressure without compromising comfort for the end-users.
- **Community water supply**
We help create reliable, sustainable, and low-risk community water systems from source to tap, including water management and revenue collection systems.
- **Solar water solutions**
We supply solar-powered water pumps and complete solar water solutions that deliver unmatched flexibility with no ongoing energy costs.
- **Irrigation**
We provide cost-effective, dependable, and energy-optimised pumping solutions for our partners that require solid irrigation applications.

Wastewater expertise

Collecting, transporting, and treating wastewater is about protecting the environment by ensuring wastewater is properly treated before discharged. Our solutions for wastewater transport, flood control and the wastewater treatment build on reliability, and securing uptime from optimised pump systems and fully integrated solutions. With our technologies we can support you on opportunities for water reuse, and thus save water for the local community.

- **Wastewater transport**
Achieve better system design that tackles hydraulic issues in advance, reduces downtime and minimises risk.
- **Flood control**
We supply complete flood control systems to help protecting urban and rural areas, infrastructure, and large cities from flooding.
- **Wastewater treatment**
Maintain optimal and effective processes at mechanical, biological and chemical treatment stages.

Whether your application is residential water supply, farming, or dewatering, Grundfos has you covered

The need has never been greater. Water supplies and quality continue to be more compromised and the need to hydrate and feed a growing population continues to increase. All the while, this needs to happen in an environmentally friendly way.

Grundfos has a long history as pioneers and global leaders in submersible pumps for the groundwater segment. With our world class network of partners globally, we can meet this challenge while lowering or eliminating environmental impact.

The promise of intelligent technologies and precision agriculture

Grundfos is investing in this important market to strengthen our channels to market, products, and services, and making environmentally friendly digital solutions easy to implement. This is done with a strong focus on solar and off-grid solutions, as well as connected systems.

Intelligent digital technologies can pave the way to more sustainable water supply. Working with data-driven insights from across a fully integrated system can help save water, energy, inputs, time, and money.



Optimised water management solutions for the entire water cycle

Transform into a more sustainable future with our optimised water management solutions – without ever compromising on up-time and system reliability.

Find your next Grundfos solution: product-selection.grundfos.com



Product overview

- 14 / **Matching pumps and products to applications**
- 16 / **Digital solutions**
- 19 / **Grundfos controls, connectivity and frequency converters**
- 30 / **Submersible pumps**
- 33 / **Single-stage standard pumps**
- 39 / **Multi-stage centrifugal pumps and systems**
- 44 / **Wastewater pumps**
- 49 / **Flood Control pumps**
- 52 / **Mixers, flowmakers, aeration and ejectors**
- 56 / **Prefabricated pumping stations**
- 58 / **Dosing & Disinfection**

Matching pumps and products to applications

Optimised solutions from Grundfos draw on a comprehensive range of products. The Matrices below match our wide product range to specific water supply and wastewater applications.

RAW Water Intake

	Ground-water	Seawater	Rivers & Lakes	Recycled Water	Transfer
Submersible pumps	●	●	●	●	
Single-stage standard pumps		●	●	●	●
Multi-stage centrifugal pumps & systems			●	●	●
Wastewater pumps		●	●	●	●
Flood control pumps		●	●	●	
Mixers					
Flowmakers					
Aeration					
Ejectors					
Prefabricated pumping stations					
Controls, connectivity & frequency converters	●	●	●	●	
Dosing & disinfection					
Digital Solutions	●	●	●	●	●

Drinking Water Treatment

	Chemical Treatment	Desalination	Flocculation	Sedimentation	Filtration	Backwash	Disinfection	Water Reservoirs
Submersible pumps								
Single-stage standard pumps	●	●		●	●	●	●	●
Multi-stage centrifugal pumps & systems	●	●		●	●	●	●	
Wastewater pumps			●	●				●
Flood control pumps								
Mixers			●					
Flowmakers			●					
Aeration			●					
Ejectors								
Prefabricated pumping stations								
Controls, connectivity & frequency converters	●	●	●	●	●	●	●	●
Dosing & disinfection	●	●	●	●	●	●	●	●
Digital Solutions	●	●	●	●	●	●	●	●

Water Distribution

	Distribution	Local Stations	Boosting	Water Towers
Submersible pumps	●			
Single-stage standard pumps	●	●	●	●
Multi-stage centrifugal pumps & systems	●	●	●	●
Wastewater pumps				
Flood control pumps				
Mixers				
Flowmakers				
Aeration				
Ejectors				
Prefabricated pumping stations			●	
Controls, connectivity & frequency converters	●	●	●	●
Dosing & disinfection	●	●	●	●
Digital Solutions	●	●	●	●

Wastewater Transport & Flood Control

	Pumping from inside building	Main Pumping Station	Pressurised Pumping Station	Network Pumping Station	Flood Control
Submersible pumps					
Single-stage standard pumps	●	●	●	●	●
Multi-stage centrifugal pumps & systems					
Wastewater pumps	●	●	●	●	●
Flood control pumps		●			●
Mixers		●		●	●
Flowmakers					
Aeration					
Ejectors					●
Prefabricated pumping stations	●	●	●	●	●
Controls, connectivity & frequency converters	●	●	●	●	●
Dosing & disinfection					
Digital Solutions	●	●	●	●	●

Wastewater Treatment

	Inlet	Primary Treatment	Chemical Treatment	Biological Treatment	Tertiary Treatment	Sludge Treatment
Submersible pumps						
Single-stage standard pumps	●	●	●		●	
Multi-stage centrifugal pumps & systems					●	
Wastewater pumps	●	●	●	●	●	●
Flood control pumps	●			●	●	
Mixers	●		●	●	●	●
Flowmakers				●		
Recirculation pumps				●		
Aeration		●		●		
Ejectors		●		●		
Prefabricated pumping stations	●					
Controls, connectivity & frequency converters	●		●	●	●	
Dosing & disinfection		●	●	●	●	●
Digital Solutions	●	●	●	●	●	●



Grundfos digital solutions

Billions of data points are harvested every day but too little of that data is being put to use effectively. Grundfos digital solutions help you leverage data from different sources and put them to use for better prediction, prioritising and planning. Our vision is to work together with utilities around the world to drive a water revolution, using unmatched data insights, expertise, and autonomous end-to-end solutions.



ANALYTICS – GRUNDFOS UTILITY ANALYTICS*

Developed in partnership with Baseform, Grundfos Utility Analytics is one of the most comprehensive monitoring and asset management solutions for water and wastewater networks. The digital tool gives urban water utilities a unique opportunity to improve network efficiency using big data.

COMMUNICATION

- Relevant data can be imported by data agents (small Java open-source programs) via an authenticated REST web service
- All communication occurs using high-grade encryption SSL channels (same as online banking)
- Agents are read-only (one-way) mechanisms unilaterally controlled by the client to ensure the utmost privacy

BENEFITS

- Make informed, fact-based decisions in every task, from daily maintenance to CAPEX investments
- Prioritise CCTV inspections and pipe replacement based on data-driven intelligence
- Detect infiltration & rain derived inflow, using weather forecast to prevent spills and flooding
- Lower response time to leaks and other network incidents

- A digital twin of your network bringing together all your data, the analytical outcome and your KPIs under holistic, intuitive and easy to use overviews. For all departments within a water utility to visualise and take action

APPLICATIONS

- **WATER DISTRIBUTION**
- **WASTEWATER TRANSPORT**

* Available in France, Germany, Italy, United Kingdom, Poland, Sweden, Norway, Denmark, Belgium, Netherlands and Texas



REMOTE MANAGEMENT – GRUNDFOS CONNECT

Grundfos Connect is an efficient and cost-effective remote monitoring and control platform and opens the door for future AI and cloud-based algorithm technologies for operation and optimization. The Internet-based solution provides customers with reliable performance data at a very low cost—and with complete system security and reliability.

COMMUNICATION

- CIM/CIU communication interfaces enable data transmission from Grundfos pumps and controllers
- Built-in multi-purpose I/O board allows the connection of sensors and switches

- Cost-efficient and simple integration. Grundfos Connect is an agnostic solution that is simple to set up, configure and utilise with a cyber-secure self-service setup providing a guided workflow for all actions. No need for costly installations from a control engineer, new SCADA integrations, or costly hardware.

BENEFITS

- Monitoring 24/7 - Secure peace of mind with continuous visibility of all your assets' performance with a cloud-based system accessed from your preferred device.
- Remote control - Spend less time on the road, increase service availability and reduce inspection costs by controlling and troubleshooting assets remotely.
- Be informed - Notifications alert you of potential issues so you can take preventive actions, avoid costly service interruptions, and secure operational performance.

APPLICATIONS

- **RAW WATER INTAKE**
- **DRINKING WATER TREATMENT**
- **WATER DISTRIBUTION**
- **WASTEWATER TRANSPORT**
- **FLOOD CONTROL**
- **WASTEWATER TREATMENT**

PREDICTIVE MAINTENANCE GRUNDFOS MACHINE HEALTH

Grundfos Machine Health is a predictive maintenance solution that provides real-time actionable insights to improve the health of your rotating equipment. Data is collected through our wireless sensors and securely stored in our user-friendly cloud-based platform, enabling remote visibility and reliability insights at all times with predictive failure using AI driven machine learning.

Applicable to all rotating assets including pumps, fans & blowers, compressors, chillers, transmissions and other production equipment.



COMMUNICATION

- Wireless sensors on your assets will capture vibration, temperature and magnetic flux data and transmit to a central communication device located in the same machine room using bluetooth
- Encrypted communication protocol using cellular / wifi to a secure cloud platform
- User access to platform via desktop and mobile phone

APPLICATIONS

- **RAW WATER INTAKE**
- **DRINKING WATER TREATMENT**
- **WATER DISTRIBUTION**
- **WASTEWATER TRANSPORT**
- **FLOOD CONTROL**
- **WASTEWATER TREATMENT**

BENEFITS

- Live, accurate and actionable insights to improve your pumps and machines delivered immediately to your web platform
- Grundfos Machine Health will send you real-time alerts and reports in the event that it detects a malfunction
- Customer success representatives and expert vibration analysts are on hand 24/7 to provide immediate and continuous support
- 30% lower maintenance costs, 75% fewer breakdowns, 20% less energy, 45% more uptime
- Predictive condition monitoring allowing to plan ahead and reduce machine downtime



Grundfos controls, connectivity & frequency converters

With dedicated communication modules and controls, you get trouble-free operation with application-specific features, energy optimisation and a wide selection of communication protocols. The dedicated functionality and start-up wizards make commissioning easy, ensuring you experience the full benefit with fingertip control of your system on a computer, tablet or smartphone.



MOBILE PUMP CONTROL – GRUNDFOS GO

Designed to save time and effort for the pump owner, this is the most comprehensive platform for mobile pump on the market, offering intuitive, handheld assistance and access to the Grundfos online tools, saving valuable time in reporting and data collection.

COMMUNICATION

- Wink function, live data feed, frequently needed shortcuts (wizard), and improved alarm logging
- User-friendly interface
- Supports Radio and Infrared communication to existing products using the universal MI 301 dongle as well as BLE (Bluetooth Low Energy) communication for newer products

BENEFITS

- Group pumps, change configuration parameters and monitor pump data
- Descriptive error codes make trouble shooting easy and intuitive
- Time saving, with quick links to documentation, replacement tool, and automatic updates

APPLICATIONS

- **WATER DISTRIBUTION**
- **WASTEWATER TRANSPORT**



FIELDBUS COMMUNICATION INTERFACES – CIM/CIU

The Grundfos fieldbus concept is the ideal solution for complete control of pumps and pump systems. The Communication Interface Module (CIM) and the Communication Interface Unit (CIU) enable data communication via open and interoperable networks.

COMMUNICATION

- Available with GENibus, BACnet MS/TP, BACnet/IP, LON, Modbus RTU, Modbus TCP, PROFIBUS DP, PROFINET IO, EtherNet/IP, Modbus data over cellular 3G/4G, secure communication to Grundfos iSOLUTIONS Cloud applications

- CIM 260 3G/4G cellular data is mainly used in Europe for water supply and wastewater applications
- CIM 280 3G/4G cellular GIC and CIM 550 Ethernet GIC are used together with Grundfos iSOLUTIONS Cloud applications
- CIM 300 BACnet is used for building automation
- CIM 500 is a versatile module supporting Industrial Ethernet solutions. It currently supports PROFINET IO, Modbus TCP, BACnet/IP and EtherNet/IP
- CIU 900/ 901/902/903 boxes to mount a CIM xxx interface

BENEFITS

- Ease of installation and commissioning, user-friendliness, and great value for money
- All modules are based on standard functional profiles for easy integration into the network and easy understanding of data points
- Supports a wide range of Grundfos products

APPLICATIONS

- **RAW WATER INTAKE**
- **WATER DISTRIBUTION**
- **WASTEWATER TRANSPORT**

COMPONENTS

- CIM 100/110 LON is mainly used for HVAC applications
- CIM 150 Profibus DP is mainly used for factory and process automation
- CIM 200 Modbus RTU is used for versatile automation e.g. HVAC and wastewater applications



MOTOR PROTECTION UNIT – MP 204

Reliable, easy to set up and easy to use motor protection for all Grundfos pumps and applications, for motors ranging from 3 to 999 amps and voltages from 100 to 480 VAC that protects pump motors against under-voltage, overvoltage and other variations in power supply and overheating.

COMMUNICATION

- Supports communication with monitoring equipment or other external units via a number of different fieldbus protocols using the Communication Interface Unit (CIU)
- Compatible with Grundfos Remote Management
- Connect to any SCADA system, allowing remote access to pump data anywhere

BENEFITS

- Power factor measurement, giving an indication of clogging in the intake or impeller wear
- Motor power consumption continually checked with precision, stopping the pump before dry-running and preventing pump damage
- Alerts for ground failure/insulation resistance, allowing preventive maintenance of the motor, cables, or cable joints

COMPONENTS

- The Control MP204 cabinet is also available with DOL (Direct on-line), SD (Star delta) and SS (Soft starter) starting methods

APPLICATIONS

- **RAW WATER INTAKE**
- **DRINKING WATER TREATMENT**
- **WATER DISTRIBUTION**
- **WASTEWATER TRANSPORT**
- **FLOOD CONTROL**
- **WASTEWATER TREATMENT**



DEMAND DRIVEN DISTRIBUTION – DDD

Grundfos Demand Driven Distribution is the first pressure management solution that combines precise measurement of the network pressure and advanced pump control at the pumping station according to these measurements. The solution compensates for excessive system pressure by adapting the setpoint to the actual flow. This is done by measuring pressure at critical points in the system.

COMMUNICATION

- Supports communication with monitoring equipment or other external units via a number of different fieldbus protocols using the Communication Interface Unit (CIU)
- Connect to any SCADA system, allowing remote access to pump data anywhere

BENEFITS

- Reduced leakage (Non-Revenue water) – less water lost through leakage and pipe bursts
- Energy savings – reduce the excessive energy used because pressure is too high and for pumping water lost through leakage
- Reduced operation and maintenance costs – lower average pressure decreases costs of leakage repairs and extends system lifetime

COMPONENTS

- The basic component of the DDD system are:
- CU 354 to control unit
- IO 351 to basic I/O unit
- CIU 250 with CIM 040 - GSM interface to remote sensors
- Xilog 1P Remote critical point sensor
- Sofrel LS 42 Remote critical point sensor

APPLICATIONS

- **WATER DISTRIBUTION**



MULTI-PUMP CONTROLLER – MPC

Grundfos Control MPC is a control cabinet with a CU352 controller that permits monitoring and control of up to six identical pumps connected in parallel. The Control MPC is easy to install and configure and offers standby pump allocation, forced pump changeover and dry-running protection to help increase system reliability, reduce downtime and costly maintenance. Soft pressure build-up minimises risk of water hammer, reducing the risk of leakage and costs of pipe maintenance.

COMMUNICATION

- Supports communication with monitoring equipment or other external units using the Communication Interface Module (CIM) via a number of different fieldbus protocols
- Compatible with Grundfos Remote Management

BENEFITS

- Intelligent cascade controller based on pump efficiency
- Pump cut-in/out is based on pump characteristics, determined by the controller and works with any type of pump
- Leakage detection in non-return valves, protecting against water loss
- Reduced wear due to cavitation (pump outside duty range feature)

COMPONENTS

The basic components of the Control MPC are:

- CU 352 – control unit
- IO 351 – primary I/O unit

The Control MPC comes in variants for mains operation, for external VFD speed control, or with speed control built in.

APPLICATIONS

- **WATER DISTRIBUTION**



EXTERNAL FREQUENCY CONVERTERS – CUE

A complete range of external frequency converters designed for speed control of a wide range of Grundfos pumps for water supply, wastewater and irrigation applications. The quick start-up guide comes with pre-defined parameters that suit the Grundfos pumps and motors, even permanent magnet motors, for optimal performance and protection of the pump.

COMMUNICATION

- Modbus RTU
- Supports communication with monitoring equipment or other external units via a number of different fieldbus protocols using the Communication Interface Unit (CIU)
- Compatible with Grundfos Remote Management

BENEFITS

- Predefined control modes, sensor range and pump family data make it very easy to commission complete pump systems in just a few steps, e.g., no need for PID tuning nor stop function test against closed valve.
- Constant pressure twin pump system with alternation, backup or cascade also built into to start-up guide.
- Application specific features, like pipe filling to avoid water hammer in water intake or de-ragging to unblock the pump in wastewater

COMPONENTS

- Full range available in IP20 and IP55/IP54 up to 250kW
- Full range motor filters available in IP20 or IP54
- Safe torque off (STO) variants are available
- Built-in mains disconnect variants are available
- High starting torque (constant torque) variants are available
- MP 204 motor protection

APPLICATIONS

- **RAW WATER INTAKE**
- **DRINKING WATER TREATMENT**
- **WATER DISTRIBUTION**
- **WASTEWATER TRANSPORT**
- **FLOOD CONTROL**
- **WASTEWATER TREATMENT**



WASTEWATER CONTROLS – DEDICATED CONTROLS

Control up to six pumps in wastewater applications in main, network and pressurised pumping stations. A range of advanced features allow for system measurement and calculation, and integration with other monitoring, control and energy optimising equipment.

COMMUNICATION

- Supports communication with monitoring equipment or other external units Communication Interface Module (CIM) via a number of different fieldbus protocols
- Communication using wired or wireless (GPRS/GSM) networks to SCADA and BMS systems

BENEFITS

- The anti-clogging attributes of the flush and reverse function are unique to Dedicated Controls, as is the ability for continuous energy optimisation according to duty condition
- User-friendly display interface with an intuitive and easy-to-follow installation wizard and you can also choose your language

- In addition to a comprehensive range of basic features, defined inputs/outputs can be added for system functions specific for the pumping station

COMPONENTS

- The main components of the system Dedicated Controls are:
- CU 362 – control unit
- IO 351 – basic I/O module
- IO 113 – protection module for pumps sensors
- SM 113 – sensor module

APPLICATIONS

- **WASTEWATER TRANSPORT**
- **FLOOD CONTROL**
- **WASTEWATER TREATMENT**



LEVEL CONTROLLERS – LC 231 / LC 241 – FOR WASTEWATER PITS

Designed for installations with one or two pumps, the Grundfos LC level controller is ideal for emptying and filling related to small wastewater transport, commercial buildings, and tank-filling applications. The controller can support up to five control levels for analogue level transmitter or float switch operation. The controller warns you with an alarm in the event of current overload, pump overheating, dry running, high water level, incorrect phase sequences or missing phase, sensor inconsistency or failure, intrusion detected, water on floor, too many restarts and moisture in pump.

COMMUNICATION

The controller uses open protocols for connection to any SCADA via the Grundfos CIM module concept.

BENEFITS

- Automatic pump changeover, ensuring even distribution of operating hours on both pumps
- Easy configuration and monitoring via Grundfos GO
- Intuitive user interface

COMPONENTS

Grundfos LC level controllers are available in two variants:

- LC 231 – a compact solution complete with certified motor protection supporting pumps up to 5,5 kW
- LC 241 – a cabinet solution offering modularity and customisation supporting pumps up to 30 kW
- A comprehensive range of options and accessories is available for the LC Level controller

APPLICATIONS:

- **SMALL WASTEWATER TRANSPORT**
- **COMMERCIAL BUILDINGS**
- **TANK FILLING APPLICATIONS**



LEVEL CONTROLLERS – LC 232 / LC 242 – FOR BOREHOLE APPLICATIONS

Designed for applications with one or two pumps, the Grundfos LC 232 and LC 242 controller is ideal for water intake applications in private installations or smaller waterworks as well as water lowering on construction sites. The controller is also ideal for tank emptying or filling applications with float switch or analogue level transmitter.

The controller warns you with an alarm in the event of current overload, pump overheating, dry running, high water level, incorrect phase sequences or missing phase, sensor inconsistency or failure, intrusion detected, water on floor, too many restarts and moisture in pump.

COMMUNICATION

The controller uses open protocols for connection to any SCADA via the Grundfos CIM module concept.

BENEFITS

- Automatic pump changeover, ensuring even distribution of operating hours on both pumps
- Easy configuration and monitoring via Grundfos GO
- Intuitive user interface

COMPONENTS

Grundfos LC level controllers are available in two variants:

- LC 232 – a compact solution complete with certified motor protection supporting pumps up to 5,5 kW
- LC 242 – a cabinet solution offering modularity and customization supporting pumps up to 30 kW
- A comprehensive range of options and accessories is available for the LC Level controller

APPLICATIONS

- GROUND WATER INTAKE
- GROUND WATER LOWERING
- IRRIGATION
- TANK FILLING



FULLY DIGITAL PRE-ASSEMBLED COMPACT MEASUREMENT AND CONTROL SYSTEM – DID

The Grundfos by s::can DID systems are the perfect combination of s::can's state-of-the-art digital sensor technology and Grundfos experience in PID controlling of dosing and disinfection processes. DID systems are designed to perfectly match Grundfos dosing pumps, gas dosing systems and systems for the generation and dosing of chlorine dioxide and hypochlorite.

BENEFITS

- Complete and ready to use
- Sensors with wide measuring ranges and comprehensive standard range allows easy selection
- Intuitive user interface provides easy commissioning and operation
- Easy system integration thanks to included digital, analog and Modbus interfaces

TECHNICAL DATA

- Parameters: Free or total Chlorine, Chlorine Dioxide, Hydrogen peroxide, Peracetic acid, pH, ORP, Conductivity, Turbidity, Total organic carbon (TOC), Dissolved organic carbon (DOC), UV 254 absorption, and Temperature
- Preassembled systems with Bypass-flowcell or tank immersed sensors

APPLICATIONS

- **DRINKING WATER TREATMENT**
- **WASTEWATER TREATMENT**



PHOTOMETRIC WATER ANALYSIS – DIT-M PHOTOMETER AND DIT-L COMPACT PHOTOMETER

The DIT-M photometer and DIT-L compact photometer with the DIT-IR interface module offer water analysis from a state-of-the-art measuring unit of up to 15 parameters in water treatment. Long-term stable reagents in tablet form are used.

BENEFITS

- The DIT-M photometer operates with 6 interference filters and long-term stable LEDs as light sources without moving parts
- Up to 1000 (DIT-M) or up to 16 (DIT-L compact) data sets can be saved
- Data transfer to a PC or a printer is possible with an infrared interface via the optional DIT-IR module

TECHNICAL DATA

- DIT-M: Aluminium, bromine, chlorine, (free, total, combined), chlorine dioxide, chloride, chlorite, cyanuric acid, iron, fluoride, manganese, ozone, phosphate, pH, acid capacity KS 4.3., hydrogen peroxide
- DIT-L: Chlorine, chlorine dioxide, chlorite or ozone as well as the pH value.

APPLICATIONS

- **WATER DISTRIBUTION**
- **WASTEWATER TREATMENT**





GAS WARNING SYSTEM – CONEX® DIA-G

Preassembled systems for monitoring of gas dosing installations and ClO_2 generation systems.

BENEFITS

- Capable of monitoring two different gas storage rooms or two different gases at the same time.
- Simultaneous measurement and display of two measuring parameters
- Optimum safety
- Very short response time
- Long and maintenance-free sensor service life
- Automatic sensor recognition and auto calibration
- Separate sensor interface for Conex® DIA-G for each potentiostatic sensor
- Internal CAN bus for the connection of potentiostatic sensors
- Optional acoustic and visual alarm device

TECHNICAL DATA

Conex® DIA-G:

- Intelligent, membrane-covered gas sensors with integrated RAM for challenging measuring tasks
- Sensor type, production number, manufacturing date and slope are stored in the memory.
Gas warning system for Cl_2 , ClO_2 , O_3 (amperometric and potentiostatic probes) and NH_3 , HCl (potentiostatic probes)

APPLICATIONS

- DRINKING WATER TREATMENT
- WASTEWATER TREATMENT

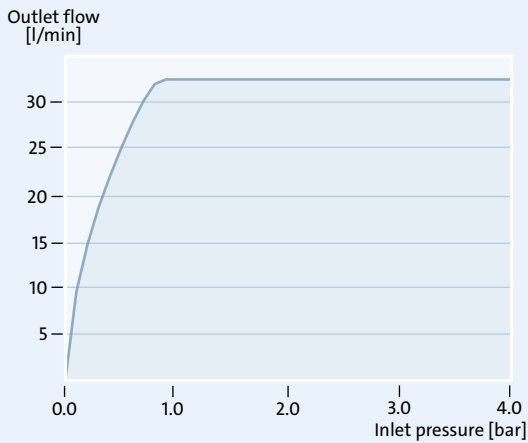

WATER DISPENSER WITH REVENUE COLLECTION AND WATER MANAGEMENT – AQtap

AQtap is an intelligent water dispenser that addresses some of the main challenges of providing a reliable and sustainable water supply in the developing world. Through an integrated platform for revenue collection and online management of water kiosks, AQtap supports the financial viability and accountability of water service operations.

BENEFITS

- Positive and transparent water tapping experience with a simple and intuitive interface and a closed water credit system using smart cards
- Efficient revenue collection platform that is flexible to be fitted to customers' organisation and setup
- Intelligent water management via remote data management to optimise and document the performance of each single water point

TECHNICAL DATA

- Nominal dispensing capacity: 1 m³/h
- Inlet and outlet connection: 3/4"
- Inlet pressure: 0.2 to 4 bar
- Dimensions: 400 x 500 x 210 mm
- Protection class: IP55
- Grid power: 110 to 240 VAC, 50/60 Hz
- Solar power: 15 to 45 VDC

APPLICATIONS

- **WATER DISTRIBUTION**



SOLAR INVERTER – RSI

The intelligent off-grid solar inverter offers the possibility to power nearly all Grundfos pumps by solar panel. A system of low (or nearly no) operating costs.

BENEFITS

- The RSI comes in two enclosure classes:
 - Up to 37kW: IP 66
 - 45kW to 250kW: in IP 54
- Advanced MPPT software which continuously optimises the system with respect to temperature as well as the solar panel conditions
- Quick setup Wizard with pre-defined parameters suits the Grundfos pumps, even permanent magnet motors.
- Works with PowerAdapt for power blending of both AC and DC power

TECHNICAL DATA

- Power size: 1.5 kW to 250 kW
- Analog and digital input
- Input: 400-800VDC, output 3x380-440VAC
- Input: 200-400VDC, output 3*208-240VAC

APPLICATIONS

- **RAW WATER INTAKE**
- **WATER DISTRIBUTION**

Submersible pumps

Grundfos is a global market leader for submersible groundwater pumps, having perfected the match between the pump, motor and protection, with monitoring and controls available for system optimisation. Grundfos is one of the world's largest manufacturers of high-quality submersible motors, and our motors match the optimum duty points for our SP and SQ pumps.



SUBMERSIBLE PUMPS – SP AND SPE

Complete range of submersible pumps for groundwater applications built to deliver optimum efficiency during periods of high demand, with long product life and easy maintenance.

BENEFITS

- State-of-the-art hydraulics provide high efficiency and low operating costs
- Made entirely of stainless steel to ensure high reliability and long lifetime, even in corrosive environments
- One supplier of the pump, motor and controls for an optimal pumping system
- Permanent magnet motor option for best in class energy efficient variable speed system

TECHNICAL DATA

- Motor size: 0.37 kW to 250 kW
- PM motor range: 4 kW to 45 kW
- Flow rate (Q): Maximum 280 m³/h
- Head (H): Maximum 670 m
- Liquid temperature: 0 °C to +60 °C
- Discharge diameter: 1" to 6"
- Diameter: 4", 6", 8", 10", 12"

APPLICATIONS

- RAW WATER INTAKE

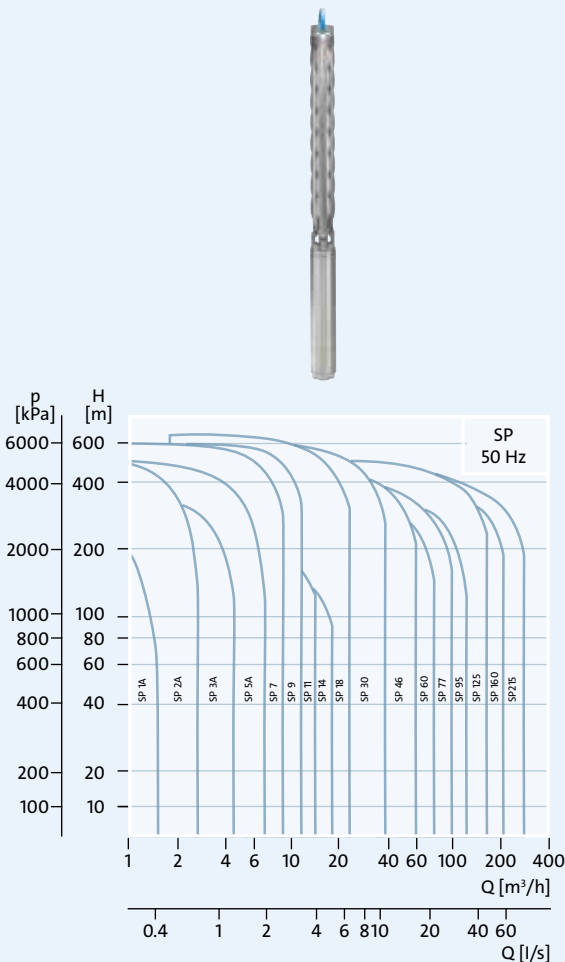

SUBMERSIBLE PUMPS – SQ AND SQE

Compact lightweight, 3" submersible multistage centrifugal pump with a wide performance range for groundwater applications.

BENEFITS

- Built-in electronics provide multiple protection features for reliable water supply at all times
- Permanent magnet motors offer excellent efficiency levels and will supply pump heads up to 180 m at rated flow
- Constant pressure option (SQE) for water supply if connected to the Grundfos CU 301 control box
- Easy to install

TECHNICAL DATA

- Motor size: 0.70 kW to 1.85 kW
- Flow rate (Q): Maximum 9 m³/h
- Head (H): Maximum 240 m
- Liquid temperature: 0 °C +40 °C
- Discharge diameter: 1" to 1½"
- Diameter: 3"

APPLICATIONS

- RAW WATER INTAKE

VARIANTS

- Two grades of stainless steel

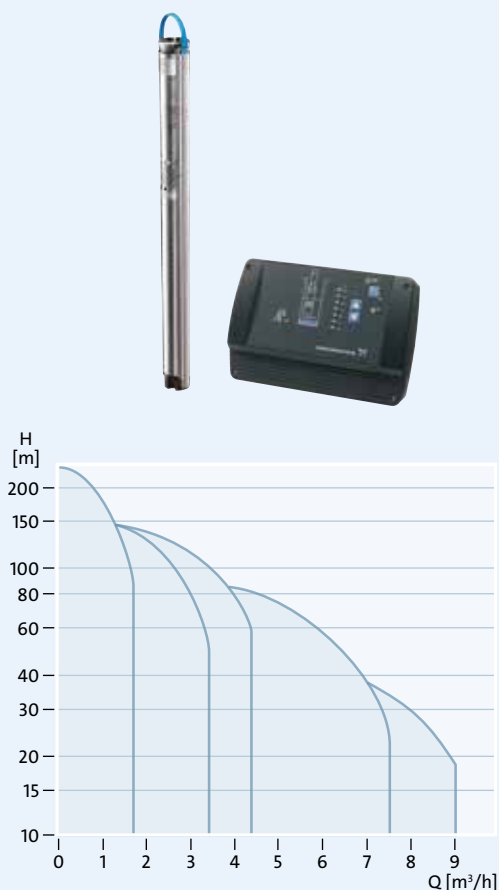



SUBMERSIBLE PUMPS – SQFlex

Intelligent Solar submersible pump with high efficiency permanent magnet motor available in both helical and multistage centrifugal hydraulic. A system offering low (or nearly no) operating costs.

BENEFITS

- High efficiency permanent magnet motor with built-in MPPT software and motor protection
- Flexibility to various power sources from AC or DC
- Tank filling system by connecting to CU 200 control box, and remote monitoring through GSM by connecting to CIU Flex

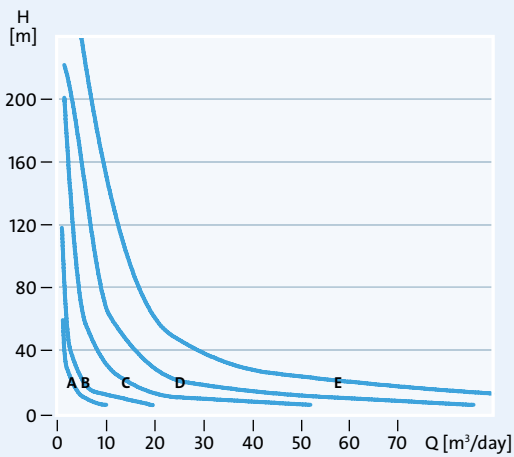

TECHNICAL DATA

- Motor size: 300 W to 2.5 kW (P1)
- Flow rate (Q): 18 m³/h
- Head (H): 250 m
- Liquid temperature: 0 °C to +40 °C
- Enclosure class: IP68
- Maximum system pressure: 15 bar
- Voltage range: 30 to 300 VDC or 1 x 90 to 240 VAC

APPLICATIONS

- RAW WATER INTAKE
- WATER DISTRIBUTION

VARIANTS

- Two grades of stainless steel



Single-stage standard pumps

Grundfos single-stage pumps are available for a wide variety of applications, where reliability and cost-efficiency is required. In water utility, single-stage pumps are generally used in raw water or water supply applications where the requirement is for low head relative to the flow and are available in both a vertical and a horizontal design.



SINGLE-STAGE END-SUCTION LARGE FLOW/LOW HEAD PUMPS – NBG/NKG

Large flow/low head multi-purpose pumps available with back pull-out design in either close- or long-coupled versions.

BENEFITS

- Dry-installed pump design ensures low investment
- Easy installation and easy serviceability during the pump lifetime

TECHNICAL DATA

- Motor size: 11 to 250 kW
- Flow rate: Up to 2300 m³/h
- Head: 2 to 40 m
- Liquid temperature: 0 to 140 °C
- Discharge diameter: DN300
- Free passage: 35 mm
- Maximum system pressure: 16 bar
- Maximum hydraulic efficiency: 86 %

APPLICATIONS

- WATER DISTRIBUTION
- WASTEWATER TREATMENT

VARIANTS

- For NBG/NKG

- Ceramic Chesterton-coated seawater pump with Duplex shaft, Duplex impeller and Hastelloy shaft seal
- Ceramic Chesterton-coated chlorinated water pump with Stainless steel shaft and Duplex impeller
- CED coated cast iron version with cast iron, stainless steel or duplex impeller.

- For long-coupled version (NKG)

- Available with 20,000-100,000 h bearing bracket design
- Available with single or double shaft seal
- Available with single or double Cartridge seal

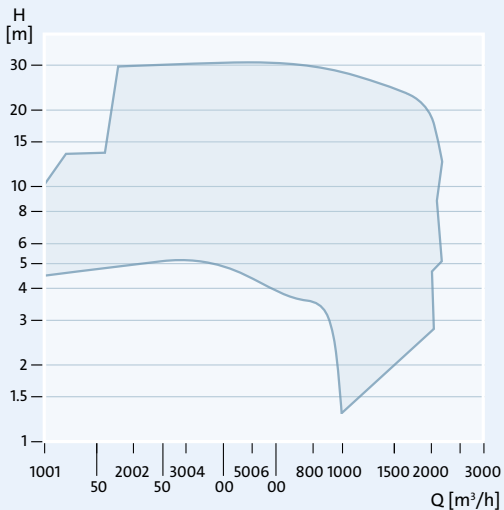



SINGLE-STAGE END-SUCTION STANDARD PUMPS – NB/NBG/NBE/NBGE

Multi-purpose end-suction pumps for reliable and cost-efficient applications such as water supply.

BENEFITS

- High efficiency
- O-ring seal between pump housing and cover means no risk of leakage
- Housing, impeller and wear ring in different materials for improved corrosion resistance, no sticking elements
- Also available with a permanent magnet MGE motor up to 22 kW with built-in variable frequency drive and IE5 efficiency

TECHNICAL DATA

- Motor size: 0.55 to 200 kW
- Flow rate (Q): Up to 1300 m³/h
- Head (H): 210 m
- Liquid temperature: -25 °C to +140 °C
- Discharge diameter: DN32 to DN250
- Free passage: 4 to 34 mm
- Maximum system pressure: 16/25 bar
- Maximum hydraulic efficiency: 88.5 %

APPLICATIONS

- RAW WATER INTAKE
- WATER DISTRIBUTION
- FLOOD CONTROL
- WASTEWATER TREATMENT

VARIANTS

- Available in a number of shaft seal and material variant

NBG/NBGE pumps are also available with Vortex impeller for enabling pumping of wastewater, process water and swarf. NBG/NBGE pumps with Vortex impellers provides passage of long long fibres and solids up to 25 mm and is suitable for wastewater with a dry matter content up to 5 %.

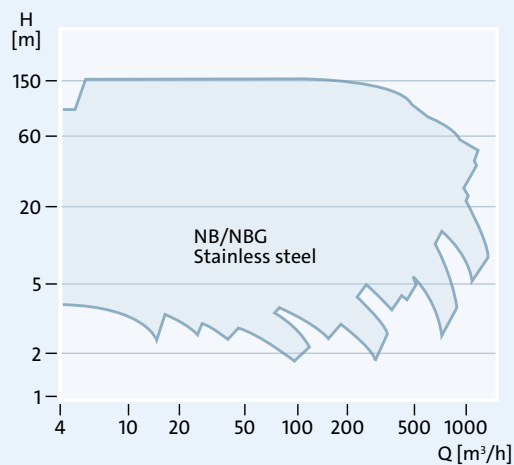
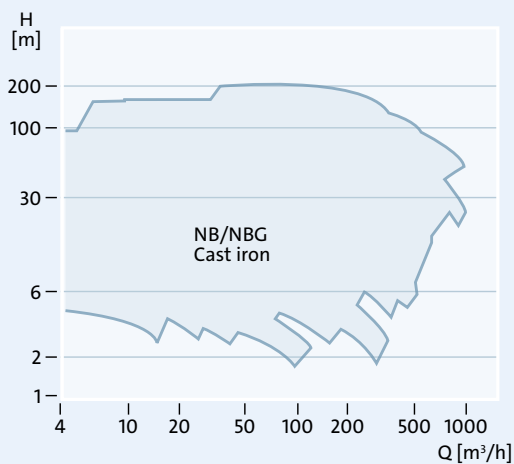



SINGLE-STAGE END-SUCTION STANDARD PUMPS – NK/NKG/NKE/NKGE

Multi-purpose end-suction pumps for reliable and cost-efficient applications such as water supply and irrigation. Back pull-out design enables removal of the motor, coupling, bearing bracket and impeller without disturbing the pump housing or pipework; these long-coupled pumps comply fully with either EN733 or ISO2858.

BENEFITS

- High efficiency
- O-ring seal between pump housing and cover means no risk of leakage
- Back pull-out design for easy dismantling for service
- Also available with a permanent magnet MGE motor up to 11 kW with built-in variable frequency drive and IE5 efficiency

TECHNICAL DATA

- Motor size: 0.55 to 460 kW
- Flow rate (Q): Up to 1300 m³/h
- Head (H): 210 m
- Liquid temperature: -25 °C to +200 °C
- Discharge diameter: DN 32 to DN 250
- Free passage: 4 to 34 mm
- Maximum system pressure: 16/25 bar
- Maximum hydraulic efficiency: 88.5 %

APPLICATIONS

- RAW WATER INTAKE
- DRINKING WATER TREATMENT
- WATER DISTRIBUTION
- FLOOD CONTROL
- WASTEWATER TREATMENT

VARIANTS

- Available in Cast iron with multiple impeller material choices
- Available in full stainless steel 1.4408
- Available in full Duplex stainless steel 1.4517
- Available with single and double seal arrangements
- Available with Grease for life or Heavy duty 100,000 hours bearing brackets

NKG/NKGE pumps are also available with Vortex impeller for enabling pumping of wastewater, process water and swarf. NKG/NKGE pumps with Vortex impellers provides passage of long long fibres and solids up to 25 mm and is suitable for wastewater with a dry matter content up to 5 %.

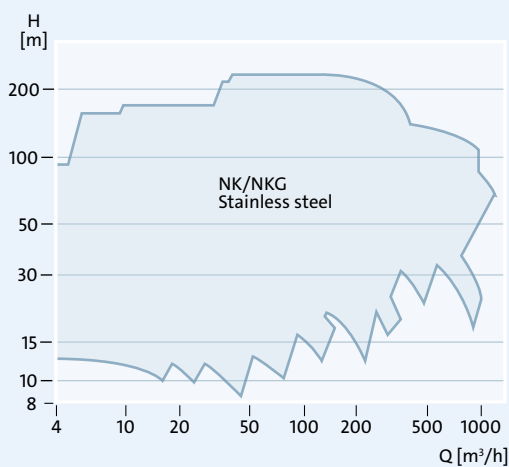
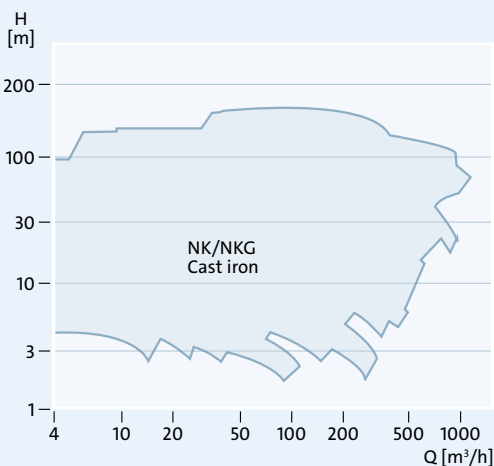



HORIZONTAL AND VERTICAL SPLIT CASE PUMPS – LS/LSV

This horizontal split case pump is a single-stage, non-self-priming, between bearing, centrifugal volute pump. The axially split design allows easy removal of the top casing and access to the pump components without disturbing the motor or pipework.

BENEFITS

- High energy efficiency and reliable design result in low life-cycle cost
- Low NPSHr
- Double suction minimises axial load, extending the life of the wear rings, shaft seals and bearings
- Double volute reduces radial forces and minimises noise and vibration

TECHNICAL DATA

- Motor size: 1.1 to 2,240 kW
- Flow rate (Q): 12 to 12,000 m³/h
- Head (H): 8 - 165 m
- Liquid temperature: 0 °C to +100 °C
- Discharge diameter: DN 50 to DN 800
- Maximum system pressure: 10 or 16 bar
- Maximum hydraulic efficiency: 91.5 %

- Bare shaft pump with baseframe
- Bare shaft pump only
- Pump with motor on separated baseframes
- Horizontal and vertical design
- Many variants available and Engineer to order on request

APPLICATIONS

- RAW WATER INTAKE
- DRINKING WATER TREATMENT
- WATER DISTRIBUTION

VARIANTS

- Pump with motor on a common baseframe
- Pump with stuffing box





VERTICAL INLINE VOLUTE PUMPS – TP/TPE

Single-stage, in-line centrifugal volute pumps with standard motors and mechanical shaft seals. Compared to end-suction pumps, in-line pumps allow a straight pipework and thus often reduced installation costs and space. TPE pumps are available with IE5 permanent magnet motor with built-in variable frequency drive and made in power sizes up to 55 kW.

BENEFITS

- Optimised hydraulics for high efficiency
- Reduced power consumption
- Also available with a permanent magnet MGE motor up to 11 kW with built-in variable frequency drive and IE5 efficiency

TECHNICAL DATA

- Motor size: 0.12 to 630 kW
- Flow rate (Q): 4500 m³/h
- Head (H): 140 m
- Liquid temperature: -25 °C to +150 °C
- Discharge diameter: DN 25 to DN 400
- Maximum system pressure: 25 bar
- Maximum hydraulic efficiency: 90 %

APPLICATIONS

- RAW WATER INTAKE
- WATER DISTRIBUTION

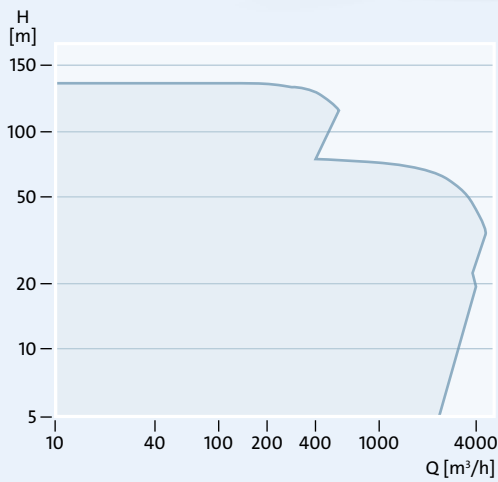



Multi-stage centrifugal pumps and systems

In water utility applications where a high head relative to the flow is required, Grundfos supplies multistage pumps that can deliver this. Our CR pumps are one of our most recognised and successful products and are at the heart of our pressure boosting systems.

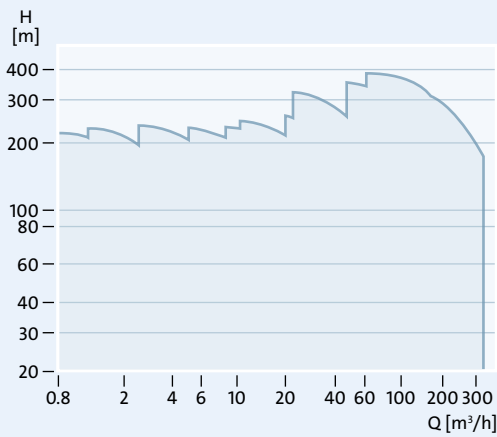

MULTI-STAGE CENTRIFUGAL PUMPS - CR/CRE

Modularity for a complete range of pump solutions; from three material variants, sixteen flow sizes (up to almost 50 bar of pressure), a variety of shaft seals, rubber materials, and supply voltages. Pump parts can be optimised and designed for specific requirements.

BENEFITS

- Also available with a permanent magnet MGE motor up to 26 kW with built-in variable frequency drive and IE5 efficiency
- Multi-flange fits a variety of standard connections for a more flexible solution
- Uniquely designed cartridge shaft seal increases reliability, reducing downtime

TECHNICAL DATA

- Motor size: 0.37 to 200 kW
- Flow (Q): Maximum 320 m³/h
- Head (H): Maximum 500 m
- Liquid temp.: -40 °C to +180 °C (240 °C, Thermal oil)
- Operating pressure: Maximum 50 bar
- Discharge diameter: Up to DN 200
- Maximum efficiency: 84 %

AVAILABLE MATERIALS

- Cast iron
- Two grades of stainless steel

APPLICATIONS

- RAW WATER INTAKE
- WATER DISTRIBUTION
- FLOOD CONTROL
- WASTEWATER TREATMENT



MULTI-STAGE CENTRIFUGAL PUMPS - CR FLEX

Solar surface pump with the high efficiency and reliability multistage CR hydraulic. A system of low (or nearly no) operating costs.

BENEFITS

- Built frequency converter with MPPT software and motor protection
- Compatible to both AC and DC, with 3 x analog input and 2 x digital input
- Uniquely designed cartridge shaft seal offers excellent reliability

TECHNICAL DATA

- Motor size: 0.88 kW or 1.73 kW (P1)
- Flow rate (Q): 20 m³/h
- Head (H): 150 m
- Liquid temperature: 0 °C to 40 °C
- Voltage range: 30 to 300 VDC or 1 x 90 to 240 VAC

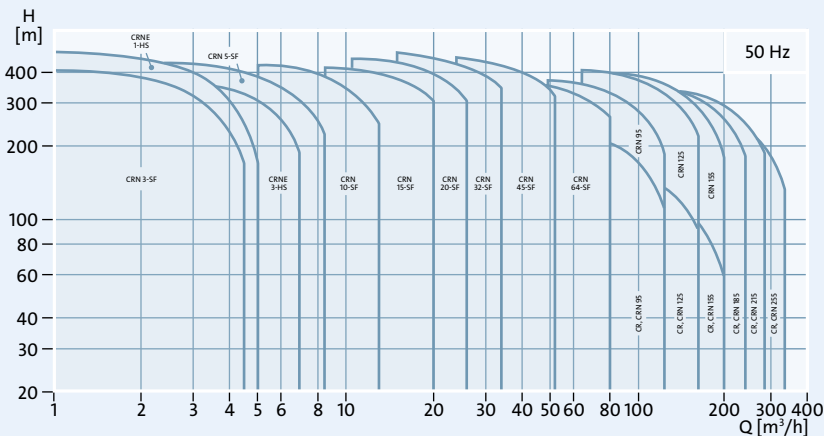

AVAILABLE MATERIALS

- Cast iron
- Two grades of stainless steel

APPLICATIONS

- RAW WATER INTAKE
- WATER DISTRIBUTION

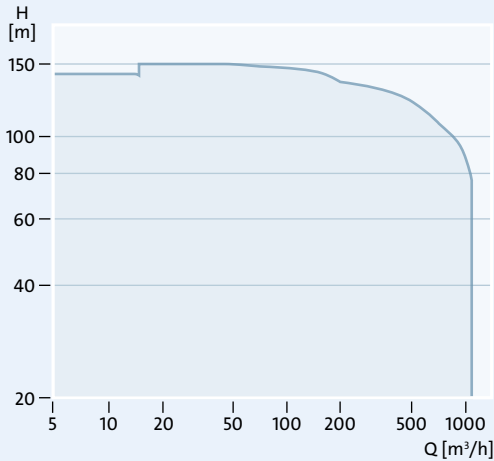

HYDRO MPC

Grundfos Hydro MPC systems come as complete units of superior quality, designed to provide boosting wherever additional pressure is needed. They are built on the world's number one multistage centrifugal pumps – the highly renowned CR and CRE pumps. The CR and CRE pumps are known for their reliability, efficiency and adaptability and form the perfect base for the Grundfos booster systems. Every component in our systems is Grundfos made which means that you are guaranteed long lasting technology that requires a minimum of maintenance and provides a maximum of efficiency.

BENEFITS

- Intelligent cascade control ensures that the optimum number of pumps required to meet the demand operate at any time
- CR pumps with IE3 motors for the most energy-efficient solution available for constant pressure during changing flow demands
- Grundfos MPC controller handles even the most difficult boosting jobs with ease and accuracy

TECHNICAL DATA

- 2 to 6 pumps
- Motor size: 0.55 to 75 kW
- Flow rate (Q): 1080 m³/h
- Head (H): 146 m
- Liquid temperature: 0 °C to +70 °C
- Discharge diameter: Up to DN 350
- Enclosure class: IP 54
- Maximum system pressure: PN16 (standard) (up to PN 40 on request)

- Maximum hydraulic efficiency: 80 %
- Ambient: 0 °C to +40 °C

APPLICATIONS

- **RAW WATER INTAKE**
- **DRINKING WATER TREATMENT**
- **WATER DISTRIBUTION**

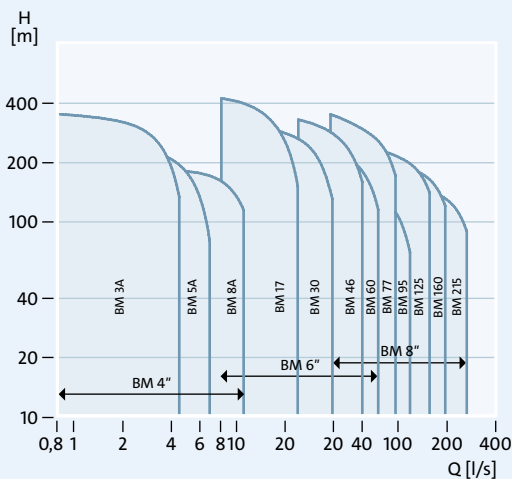

BOOSTER MODULES – BM

High-pressure booster modules for boosting, liquid transfer and circulation in systems under high static pressure and used in reverse osmosis and ultra-filtration applications in water supply, water treatment and industrial plants.

BENEFITS

- All stainless steel construction, available in three qualities: SS 304, SS 316, SS 904 L
- Easy to install and low noise
- Compact and modular design that is leakage free

TECHNICAL DATA

- Motor size: 0.75 kW to 92 kW
- Flow rate (Q): Up to 260 m³/h
- Head (H): Up to 800 m (serial connection)
- Liquid temperature: 40 °C
- Discharge diameter: Victaulic connection
- Maximum system pressure: Up to 60 bar.
- Maximum hydraulic efficiency: Up to 80 %

APPLICATIONS

- **DRINKING WATER TREATMENT**
- **WATER DISTRIBUTION**

BOOSTER MODULES – BMS hs.

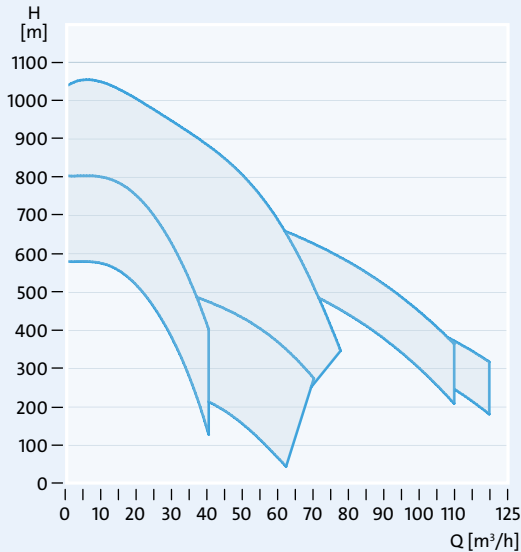

BMS hs is a range of booster systems for reverse osmosis and filtration applications. These booster systems offer higher efficiency than the previous ranges. The reason is a direct-coupled pump which is powered by a permanent-magnet high speed motor (PM) or an asynchronous high-speed motor (AC). The BMS hs pump with PM motor has a Grundfos CUE frequency drive included in the product number. The permanent-magnet solution is only suitable for 400 V. The asynchronous motor has to be controlled by a variable-frequency drive, to reach the high speed. The variable-frequency drive must fit motor voltages of 400 V and the mains supply at the installation site. Together with an improved design, this makes both maintenance and service easier than ever, and you have a winning concept. The BMS hs pump is delivered with a built-in non return valve.

BENEFITS

- Improved design that makes service and maintenance easier than ever, and at the same time increases durability and reliability
- The speed of the motor must be controlled by a variable frequency drive
- The high-speed motor also gives the BMS hs range a smaller footprint and drastically reduces the weight of the pump.
- A high-pressure variant for up to 120 bar is available on request.

TECHNICAL DATA

- Motor size: Up to 180 kW.
- Flow rate (Q): Up to 115 m³/h
- Head (H): Up to 827 m
- Liquid temp: Up to 40 °C
- Inlet/discharge: 3" Victaulic
- Insulation class (motor): IP 54
- Maximum system pressure: 350 m
- Maximum hydraulic efficiency: Up to 80 %
- Built-in check valve



BOOSTER MODULES – BMSX

The BMSX is a booster system consisting of a BMS hs pump, a BMS hp pump and an isobaric pressure exchanger. The BMSX is designed for sea water and brackish water desalination. Variable frequency drives on both motors ensures optimised operation and efficiency.

BENEFITS

- Capable of delivering 1500 m³ permeate per day with an energy recovery of up to 60 %
- Critical components made of super duplex stainless steel, polymer and ceramic, making the module extremely resistant to its operating environment
- Compact design and very small footprint

TECHNICAL DATA

- Motor size: Up to 180 kW
- Head (H): Up to 82.7 bar
- Liquid temperature: Up to 40 °C
- Inlet/discharge connections: Victaulic couplings
- Insulation class (motor): IP 55

APPLICATIONS:

- DRINKING WATER TREATMENT



Wastewater pumps

Grundfos offers a complete range of wastewater pumps, designed to handle wastewater, process water, and unscreened raw sewage in heavy-duty municipal, utility, and industrial applications.

The SE/SL pumps are built for years of trouble-free operation in the most demanding applications, can be installed submerged or dry, horizontal or vertical, and will in either case be extremely reliable and very easy to service.

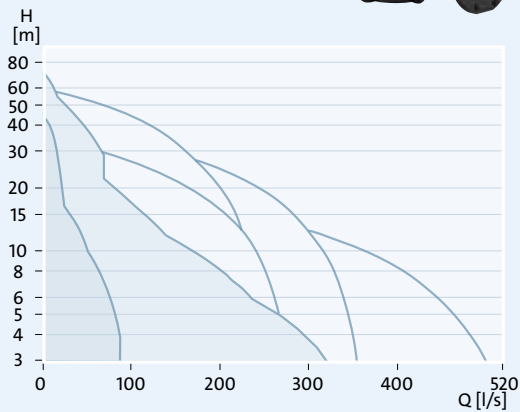

SUBMERSIBLE WASTEWATER PUMPS – SE/SL

Designed for the handling of wastewater, process water and unscreened raw sewage. The pumps can be installed submerged and/or dry.

BENEFITS

- SE/SL pumps offer you the best level of reliability due to optimised hydraulics designed with large free passage
- Highest wire-to-water efficiency available, reducing your total costs
- Highest level of service friendliness, making service of the pump trouble-free and time saving
- Plug and pump – all necessary control and protection built into the pump, eliminating complexity (For the SL 0.9-1.5kW AUTOADAPT version)

TECHNICAL DATA

- Motor size: 0.9 to 63 kW
- Flow rate (Q): Maximum 425 l/s (1525 m³/h)
- Head (H): Maximum 71.3 m
- Liquid temperature: 0 °C to +40 °C
- Discharge diameter: DN 65 to DN 300
- Free passage: Up to 125 mm
- Insulation class: H
- Maximum efficiency: 83.7 %
- Maximum system pressure: PN10

AVAILABLE MATERIALS

- Stainless steel impeller (SE, SL)
- Stainless steel variants for standards EN 1.4408 and EN 1.4517/1.4539 (SE)

APPLICATIONS

- **RAW WATER INTAKE**
- **DRINKING WATER TREATMENT**
- **WASTEWATER TRANSPORT**
- **FLOOD CONTROL**
- **WASTEWATER TREATMENT**

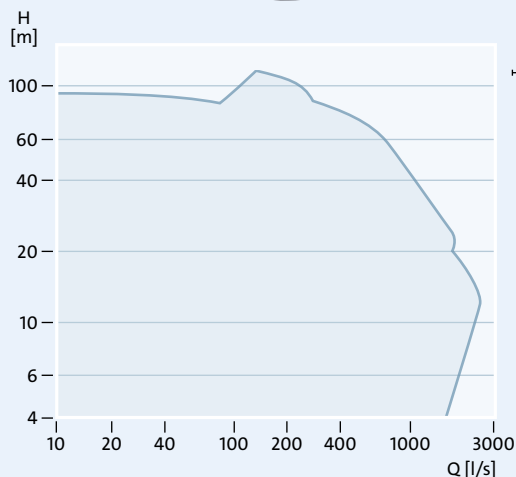

SEWAGE PUMPS – S RANGE

Highly dependable, powerful sewage pumps, designed for handling unscreened raw sewage, acknowledged for their strength, their durability, and for innovative features such as SmartTrim impeller clearance adjustment system and SmartSeal for leakage prevention.

BENEFITS

- High efficiency and excellent non-clogging capabilities with large free passage of 80 to 145 mm
- Patented SmartTrim system for extremely easy impeller adjustment without dismantling the pump, to maintain peak performance and keep lifecycle costs low.
- The SmartSeal auto-coupling gasket provides a completely leak-proof connection between the pump and the base unit of the auto-coupling system

TECHNICAL DATA

- Motor size: Up to 520 kW
- Flow rate (Q): 2500 l/s (9000 m³/h)
- Head (H): 116 m
- Liquid temperature: 0 °C to +40 °C
- Discharge diameter: 80 to 600
- Free passage: Up to 145 mm
- Insulation class: F (H on request)
- Maximum system pressure: PN 10
- Maximum hydraulic efficiency: 85 %

VARIANTS

- Stainless steel variants to EN 1.4408
- Sensors available for monitoring the pump: bearing and winding temperature, vibrations and water in oil
- A wide range of possibilities for customising to customers requirements

APPLICATIONS

- **RAW WATER INTAKE**
- **WASTEWATER TRANSPORT**
- **FLOOD CONTROL**
- **WASTEWATER TREATMENT**



GRINDER PUMPS – SEG/SEG AUTOADAPT

Submersible sewage grinder pumps for pressurised wastewater pumping designed to optimise performance in your system. The adaptive intelligence built into the AUTOADAPT version minimises risk factors and reduces costs for installation, commissioning and maintenance.

BENEFITS

- High discharge pressure enables transfer of wastewater over longer distances
- Plug and pump – all necessary control and protection built into the pump, eliminating complexity (AUTOADAPT version)
- Wear resistant grinder system which grinds solids into small pieces, so they can be pumped away through discharge pipes of a small diameter

TECHNICAL DATA

- Motor size: 0.9 to 4 kW
- Flow rate (Q): 9.51 l/s (36 m³/h)
- Head (H): 45.7 m
- Liquid temperature: 0 °C to +40 °C
- Discharge diameter: DN 40/50
- Insulation class: F
- Free passage: Grinder
- Insulation Class: IP68

APPLICATIONS

- WASTEWATER TRANSPORT

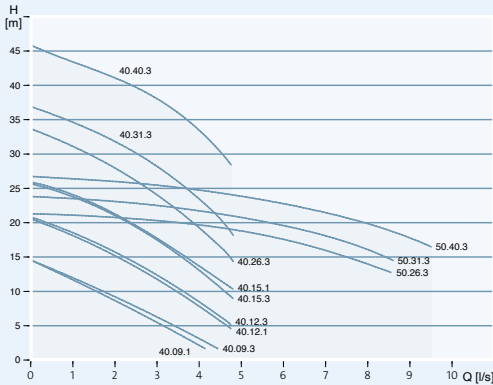

DRAINAGE SEWAGE PUMPS – DP AUTOADAPT

Transportable multi-vane, semi-open impeller pumps specifically designed for a range of drainage applications with solids handling up to 10 mm. The pumps are made of wear-resistant materials, such as cast iron and stainless steel to ensure reliable operation. The adaptive intelligence built into the AUTOADAPT versions minimises risk factors and reduces costs for installation, commissioning and maintenance

BENEFITS

- For use free-standing or for installation on an auto-coupling system with an integrated three-leg stand that keeps the suction inlet clear of the pit bottom
- Patented SmartTrim system for extremely easy impeller adjustment without dismantling the pump, to maintain peak performance; no special tools are required
- Plug and pump – all necessary control and protection built into the pump, eliminating complexity (AUTOADAPT version)

TECHNICAL DATA

- Max flow 12.5 l/s (45 m³/h)
- Max head: 25 m
- Motor size: 0.9 to 2.6 kW
- Discharge diameter: R2" + DN65
- Free passage: 10 mm
- Insulation class: F

APPLICATIONS

- FLOOD CONTROL
- WASTEWATER TRANSPORT

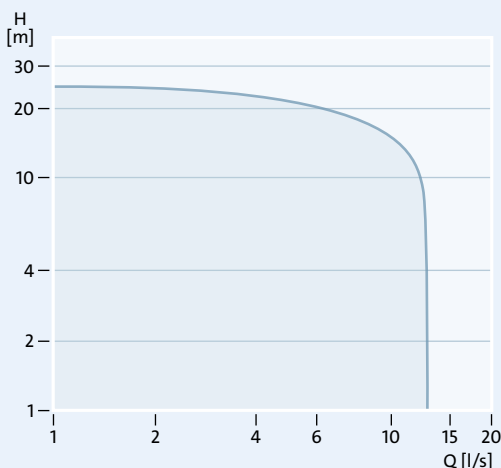



EFFLUENT SEWAGE PUMPS – EF AUTOADAPT

Suitable for pumping effluent and other liquids such as drainage and surface water with small impurities and solids handling up to 30 mm size, with a rigid or flexible discharge pipe mounted on the discharge port. The adaptive intelligence built into the AUTOADAPT versions minimises risk factors and reduces costs for installation, commissioning and maintenance.

BENEFITS

- For use free-standing or for installation on an auto-coupling system with an integrated three-leg stand that keeps the suction inlet clear of the pit bottom
- Patented SmartTrim system for extremely easy impeller adjustment without dismantling the pump, to maintain peak performance; no special tools are required
- Plug and pump – all necessary control and protection built into the pump, eliminating complexity (AUTOADAPT version)

TECHNICAL DATA

- Max flow 12.9 l/s (46 m³/h)
- Max head: 22 m
- Motor size: 0.6 to 1.5 kW
- Discharge diameter: R2"
- Free passage: 30 mm
- Insulation class: F

APPLICATIONS

- FLOOD CONTROL
- WASTEWATER TRANSPORT

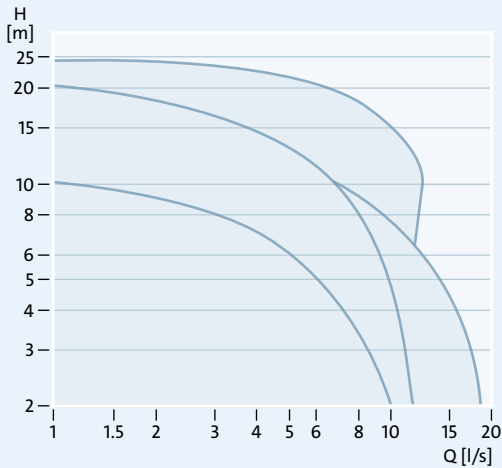



HEAVY-DUTY DEWATERING PUMPS – DWK

Contractor pumps for construction dewatering in building and infrastructure sites, designed with semi-open or enclosed impeller. Made of corrosion-resistant materials such as cast iron and high-chrome stainless steel, for harsh environments.

BENEFITS

- High reliability and flexibility pumps with protection features for harsh operating environments
- Top-discharge with different connection types available for multiple use of the pump, depending on conditions and specific needs
- Pumps up to 15 kW have a double mechanical seal and pumps from 22 kW to 90 kW have a triple-seal system, for longer operation and less downtime

TECHNICAL DATA

- Motor size: 0.75 to 90 kW
- Flow rate (Q): 120 l/s (430 m³/h)
- Head (H): 160 m
- Liquid temperature: 0 °C to +40 °C
- Discharge diameter: 2" to 6"
- Free passage: Strainer
- Insulation class: F
- Maximum hydraulic efficiency: 75 %

APPLICATIONS

- WASTEWATER TRANSPORT
- FLOOD CONTROL

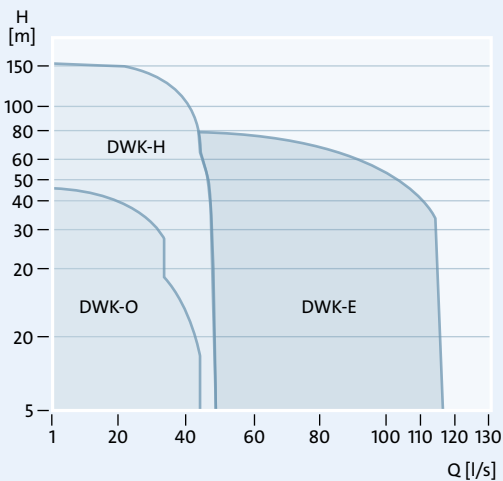

SUBMERSIBLE DRAINAGE PUMPS – DPK

Drainage pumps designed with semi-open or enclosed impeller for pumping water in a wide range of applications. The pumps are made of robust cast iron, ensuring durable operation.

BENEFITS

- Semi-open ductile cast iron impeller maintains its performance, ensuring an increased lifetime
- Submerged free-standing installation, or submerged installation on an auto-coupling system
- The double mechanical seal is positioned in the oil chamber and ensures trouble-free operation

TECHNICAL DATA

- Motor size: 0.75 to 22 kW
- Flow rate (Q): 45 l/s (165 m³/h)
- Head (H): 56 m
- Liquid temperature: 0 °C to +40 °C
- Discharge diameter: DN 50 to DN 150
- Free passage: 10 to 20 mm
- Insulation class: F
- Maximum hydraulic efficiency: 74 %

APPLICATIONS

- WASTEWATER TRANSPORT
- FLOOD CONTROL

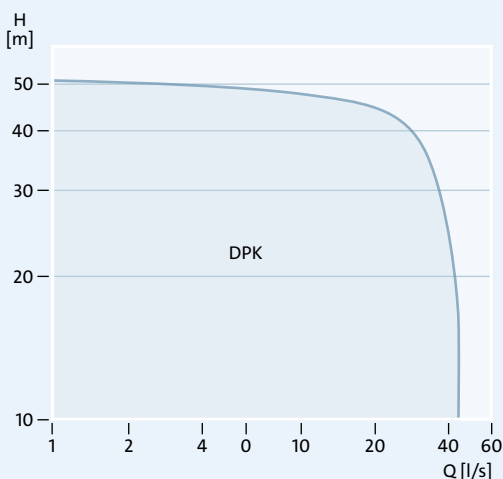

Flood control

Flood control pumping is characterised by a requirement for pump solutions with high flow and low head. The powerful Grundfos range of axial and mixed-flow pumps for flood control are specifically designed for durable use in pumping stations, harbour management and stormwater tank solutions.

Flood control pumps are individually engineered to suit your requirements, ensuring cost-efficient performance. Including Grundfos during the planning stages of the flood control solution ensures that all aspects are considered, such as pumping station design, retention tank design, pump selection, future requirements, and the total life cycle costs.



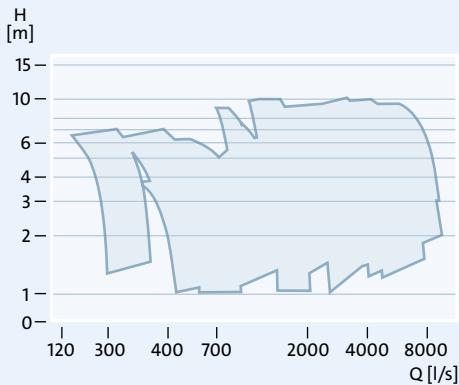

AXIAL FLOW PROPELLER PUMP – KPL

Axial flow propeller pump designed for the high flow at low head requirements of flood control and other similar duty applications. The Turbulence Optimiser™ reduces turbulence in the gap between the pump volute and the column pipe, increasing efficiency by up to two percentage points.

BENEFITS

- With the Turbulence Optimiser™, for best-in-class hydraulic efficiency of up to 86 %
- High-voltage motors for low installation costs
- High-precision one piece propeller with back-swept design reduces clogging

TECHNICAL DATA

- Motor size: 11 to 700 kW (Up to 850 kW on request)
- Flow rate (Q): 9,200 l/s (33,120 m³/h)
- Head (H): 10 m
- Liquid temperature: 0 °C to +40 °C
- Discharge diameter: Up to 2200 mm
- Insulation class: F
- Maximum installation depth: 20 m
- Maximum hydraulic efficiency: 86 %

VARIANTS

- Propeller in stainless steel is standard; other materials available on request
- Sensors for monitoring the pump: bearing and winding temperature, vibrations and water in oil

APPLICATIONS

- RAW WATER INTAKE
- WASTEWATER TRANSPORT
- FLOOD CONTROL
- WASTEWATER TREATMENT

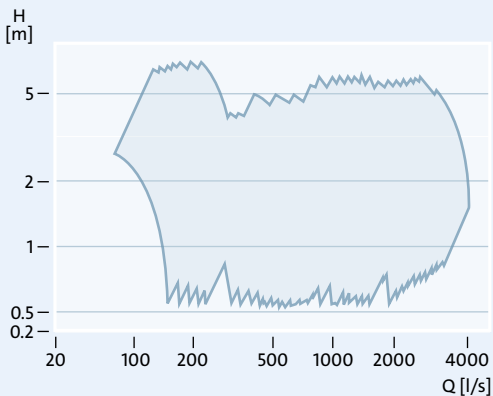

AXIAL FLOW PROPELLER PUMP – KPG

Axial flow propeller pumps are designed for horizontal installation in pump gate installations with high flow at low head requirements, such as flood control or similar duty applications with narrow or limited space.

BENEFITS

- Compact design
- Robust, reliable and efficient, offering maximum value for money
- High-precision one piece propeller with back-swept design reduces clogging

TECHNICAL DATA

- Motor size: 11 to 250 kW
- Flow rate (Q): 4,850 l/s (17,460 m³/h)
- Head (H): 7 m
- Liquid temperature: 0 °C to +40 °C
- Discharge diameter: Up to 1,400 mm
- Insulation class: F
- Maximum installation depth: 20 m
- Maximum hydraulic efficiency: 85%

VARIANTS

- Propeller in stainless steel is standard; other materials available on request
- Sensors for monitoring the pump: bearing and winding temperature, vibrations and water in oil

APPLICATIONS

- RAW WATER INTAKE
- WASTEWATER TRANSPORT
- FLOOD CONTROL
- WASTEWATER TREATMENT



MIXED FLOW PUMP – KWM

Mixed flow pump designed for the high flow at low head requirements of, wastewater treatment recirculation control and other heavy-duty pumping applications.

BENEFITS

- With Turbulence optimizer™, for best-in-class hydraulic efficiency up to 86 %
- High-voltage motors for low installation costs
- Robust, reliable and efficient, offering maximum value for money

TECHNICAL DATA

- Motor size: 11 to 700 kW (Up to 850 kW on request)
- Flow rate (Q): 5,555 l/s (20,000 m³/h)
- Head (H): 20 m (Up to 400 m on request)
- Liquid temperature: 0 °C to +40 °C
- Discharge diameter: column (FPV up to DN 2,200)
- Insulation class: F
- Maximum installation depth: 20 m
- Maximum hydraulic efficiency: 85 %

VARIANTS

- Impeller in cast iron is standard; stainless steel available on request
- Sensors for monitoring the pump: bearing and winding temperature, vibrations and water in oil

APPLICATIONS

- **RAW WATER INTAKE**
- **WASTEWATER TRANSPORT**
- **FLOOD CONTROL**
- **WASTEWATER TREATMENT**

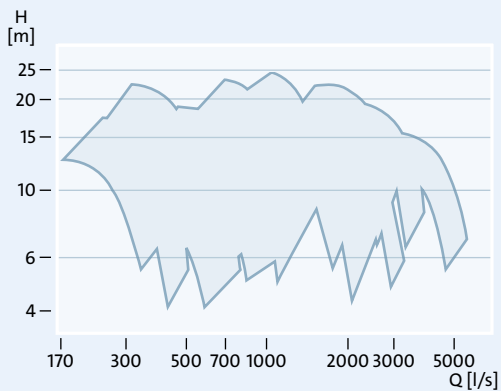



Mixers, flowmakers, aeration, ejectors and diffusers

Mixers, flowmakers and recirculation pumps available from Grundfos cover everything from small-scale mixers, ideal for prefabricated pumping stations, to large-scale flowmakers created for large tanks and basins and recirculation pumps for moving large flows at low head – a requirement often seen at treatment plants, for recirculation between process tanks.



MIXERS – SMD/SMG

Mixers for keeping particles evenly distributed in wastewater and sludge, preventing sedimentation and supporting treatment processes. Available as direct driven (SMD) versions from 0.7 to 3.5 kW, or planetary gear driven (SMG) versions from 0.9 to 18.0 kW.

BENEFITS

- Hydrodynamic optimised 2- or 3 blade propellers in stainless steel for high efficiency, reliable, and non-clogging operation
- Optimised for energy efficiency by use of IE3 motor components
- Full range of high-quality installation accessories
- Suitable for continuous and variable speed drive operation

TECHNICAL DATA

- Motor size: 0.7 to 18.0 kW
- Liquid temperature: +5 °C to +40 °C
- Thrust to power ratio:
SMD: 0.18 to 0.24 N/W
SMG: 0.25 to 0.43 N/W
- Propeller diameter:
SMD: 210 to 370 mm
SMG: 550 to 900 mm

- Propeller speed:
SMD: 967 to 1478 rpm
SMG: 269 to 359 rpm
- Axial Thrust:
SMD: 170 to 830 N
SMG: 360 to 4360 N

APPLICATIONS

- WASTEWATER TRANSPORT
- WASTEWATER TREATMENT
- DRINKING WATER TREATMENT
- MIXING IN INDUSTRIAL APPLICATIONS



FLOWMAKERS – SFG

Flowmakers for keeping particles evenly distributed in even the largest wastewater tanks and basins, preventing sedimentation and optimising the treatment process. Gear driven flowmakers from 0.7 to 8.0 kW.

BENEFITS

- Hydrodynamic optimised 2 or 3 blade propellers for high efficiency, reliable, and non-clogging operation
- Optimised for energy efficiency by use of IE3 motor components
- Full range of high-quality installation accessories
- Suitable for continuous and variable speed drive operation

TECHNICAL DATA

- Motor size: 0.7 to 8.0 kW
- Liquid temperature: +5 °C to +40 °C
- Thrust to power ratio: 0.55 to 1.34 N/W
- Propeller diameter: 1300 to 2660 mm
- Propeller speed: 26 to 88 rpm
- Axial Thrust: 665 to 6570 N

APPLICATIONS

- WASTEWATER TREATMENT
- DRINKING WATER TREATMENT
- MIXING IN INDUSTRIAL APPLICATIONS

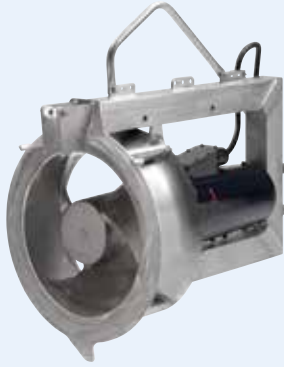

SUBMERSIBLE RECIRCULATION PUMPS – SRG

Submersible recirculation pumps to handle large flows with low heads that are equally suitable for wastewater treatment plants and flood control. The triple sealing system ensures maximum protection of the mechanical shaft seal, and the bracket makes installation very easy.

BENEFITS

- Hydrodynamic optimised stainless steel propeller for high efficiency, reliable, and non-clogging operation
- Optimised for energy efficiency by use of IE3 motor components
- Wide performance range
- Suitable for continuous and variable speed drive operation

TECHNICAL DATA

- Motor size: 0.8 to 24.0 kW
- Flow rate (Q): 1450 l/sec (5250 m³/h)
- Head (H): 2.1 m
- Liquid temperature: +5 °C to +40 °C
- Discharge diameter: 300 to 800 mm
- Maximum hydraulic efficiency: 68 %

APPLICATIONS

- FLOOD CONTROL
- WASTEWATER TREATMENT

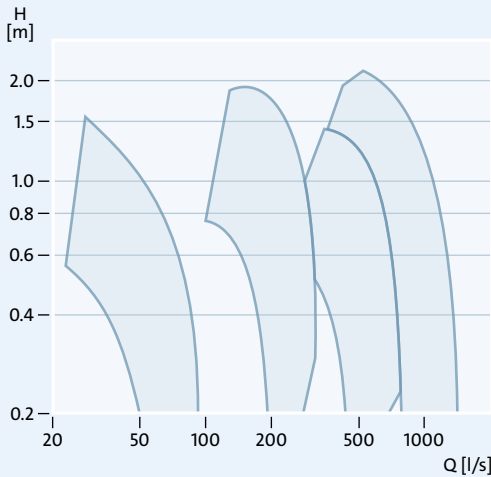

EJECTORS

Self-aspirating aerator that keeps aerobic treatment processes running and also helps to avoid odour problems in wastewater storage, as anaerobic zones can be eliminated providing mixing and aeration in the same device.

BENEFITS

- Robust industrial design for continuous operation, made completely in stainless steel for strength
- Easy to install, operate and maintain, as they do not require any blowers, air distribution piping or control valves
- Submerged aerator increases oxygen transfer time, and the submerged installation reduces noise and limits aerosol formation at the tank

TECHNICAL DATA

- Motor size: 4 to 50 kW
- Liquid temperature: 0 °C to +40 °C
- Standard Oxygen Transfer Rate at 4 m submersion: SOTR 61 [kgO₂/h]

APPLICATIONS

- WASTEWATER TRANSPORT
- FLOOD CONTROL
- WASTEWATER TREATMENT

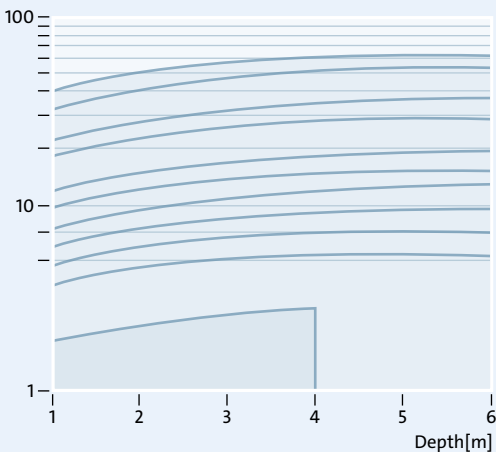

SEWAGE AERATION DIFFUSERS

A wide range of energy efficient, sturdy and flexible membrane disc and tube fine bubble diffusers for process tanks and other wastewater treatment applications. For new build or refurbishment, systems include pipes and fittings, manifold, anchors and diffusers.



BENEFITS

- Customised energy efficient, fine bubbled diffuser systems delivered with complete working layout drawings and a calculation of system performance
- Diffuser systems are delivered pre-assembled, with fast and easy one-bolt on-site installation of the air distribution pipes
- A large range of disc and tubular diffusers, with system components available in a range of materials for different wastewater types

TECHNICAL DATA

- Disc diffusers 9" & 12" Maximum $Q_{nominal}$ 8.0 Nm³/h
- Tube diffusers 2" & 3" Maximum $Q_{nominal}$ 34.0 Nm³/h

APPLICATIONS

- DRINKING WATER TREATMENT
- WASTEWATER TREATMENT

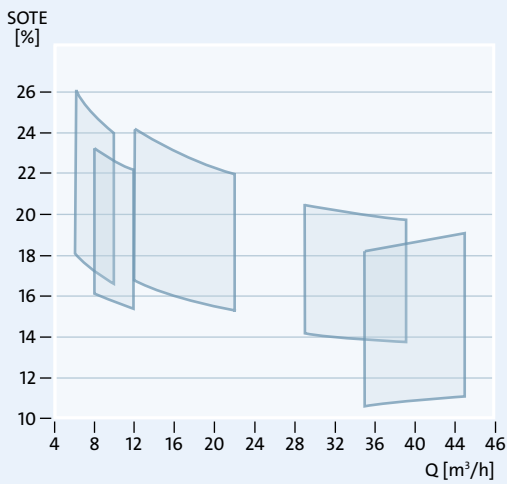
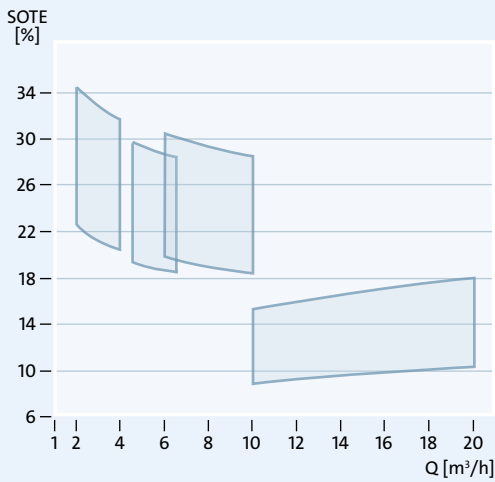



Prefabricated pumping stations

Grundfos offers a full range of functional modular pumping stations – complete with all necessary pumps, piping, valves and level controls. The pump pit, pumps and controls can be combined to suit specific requirements for each individual application.

The Grundfos prefabricated pumping stations are available in a variety of sizes and heights. Depending on the selected pump, applications can be for drainage, effluent, stormwater and wastewater. The pumping stations are made either from polyethylene (PEHD) or Glass Reinforced Polyester (GRP). All pre-installed piping is stainless steel or PEHD.



PREFABRICATED PUMPING STATIONS

Sturdy and well-designed pump pit sized to suit requirements, with up to three wastewater pumps easily installed on auto couplings.

All necessary components such as piping and valves are built in or placed in a separate valve chamber. Grundfos Dedicated Control offer operational reliability, integration and automatic optimisation.

BENEFITS

- Sturdy construction from high quality corrosion-free materials;
- Designed for easy and fast installation
- The design of the pit sump limits sludge and odour problems and is for unattended operation and remote control

PRODUCT DATA

- Maximum diameter: 400 to 3000 mm
- Maximum length: 8 m
- Material of tank: PEHD / GRP

As variant we can make other diameters and lengths

APPLICATIONS

- **WASTEWATER TRANSPORT**
- **WASTEWATER TREATMENT**
- **FLOOD TREATMENT**

DESIGN

Design your own pumping stations based on Grundfos standard components. Find our Pumping Station Creator in Grundfos Product Center under Tools or use the URL code.

COMPONENTS

- Primarily designed for up to three Grundfos wastewater pumps
- Grundfos controllers offer a full range of options for monitoring, control, communication and optimisation
- Options for level sensors, external control units and valves



Dosing and disinfection

Grundfos has one of the broadest product ranges in the market for chemical dosing and disinfection. The portfolio covers everything from disinfection of drinking water and wastewater to precision dosing of chemistry in industrial processes and sensitive membrane filtration solutions for water treatment.

Grundfos offers a complete range of dosing pumps covering a broad space for example for flocculation, disinfection and pH adjustment. Supplemented with a broad accessory portfolio, the portfolio supports customers to build complete dosing solutions, including measurement and control. Alternatively, Grundfos can design and build a turn-key dosing skid and chemical preparation solutions.

Specially for disinfection applications, Grundfos offers components and solutions for gas chlorination and on-site production of chlorine and chlorine dioxide.



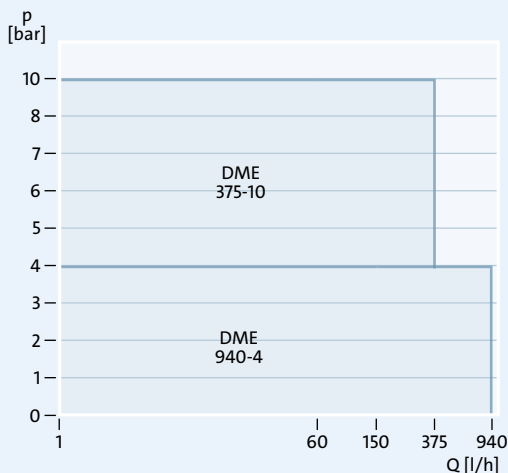
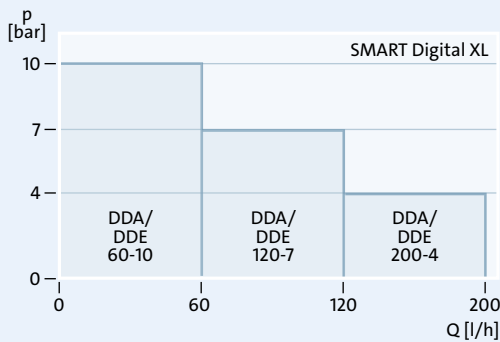
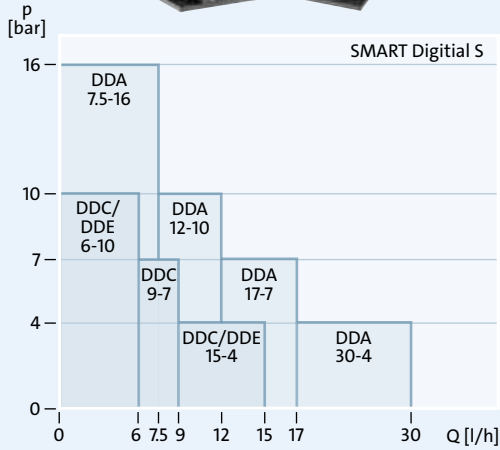

SMART DIGITAL – DDA, DDC AND DDE

Diaphragm dosing pumps with powerful variable-speed stepper or Permanent Magnet Synchronous motors offer high dosing accuracy and flow control, longer maintenance intervals due to the universal chemical resistance of the full-PTFE double diaphragm, and reduced energy consumption from the state-of-the-art drive technology.

The SMART Digital range includes the original SMART Digital DDA, DDC, and DDE pumps which cover flows up to 30 l/h, and the SMART Digital XL DDA and DDE pumps which cover flows up to 200 l/h.

BENEFITS

- **Reduced TOTEX:** simplified setup removing standard accessories, longer service intervals, and high accuracy leading to reduced energy and chemical consumption.
- **Fieldbus communication:** Profibus, Modbus RTU and TCP, Ethernet IP and Profinet for complete control and integration.
- **Modularity:** The included click-stop mounting plate and the possibility to turn the control cube in three positions are some examples of the unique flexibility offered, with only a few variants.
- **Simplicity:** Easy handling and perfect overview and control ensure simple installation, commissioning and operation.
- **Flow intelligence:** The pump monitors the dosing process of liquids when the FlowControl function is activated, for advanced process reliability.

TECHNICAL DATA

- Flow (Q): 0.0025 to 200 l/h
- Operating pressure: 4 to 16 bar
- Setting range: Up to 1:3000

APPLICATIONS

- **DRINKING WATER TREATMENT**
- **WASTEWATER TREATMENT**

DIGITAL DOSING – DME

Digital Dosing pumps that combine perfect precision and user-friendliness for large dosing quantities up to 940 l/h, offering all the benefits of the highly acclaimed smaller Digital Dosing range, making accurate dosing easier than ever.

BENEFITS

- Wide dosing range with a turndown ratio of 1:800 for a range of water supply, wastewater and water treatment applications
- Easy to install, the operator can set the pump to discharge exactly the quantity of dosing liquid required in the application
- Available with Profibus interface to supply performance data and status information for quality control, preventive maintenance and future reference

TECHNICAL DATA

- Flow (Q): 0.469 to 940 l/h
- Operating pressure: 4 to 10 bar
- Setting range: up to 1:800

APPLICATIONS

- **DRINKING WATER TREATMENT**
- **WASTEWATER TREATMENT**

VARIANTS

- The dosing heads of DME pumps are available in stainless steel, PVDF, and environmentally friendly, cost-efficient polypropylene

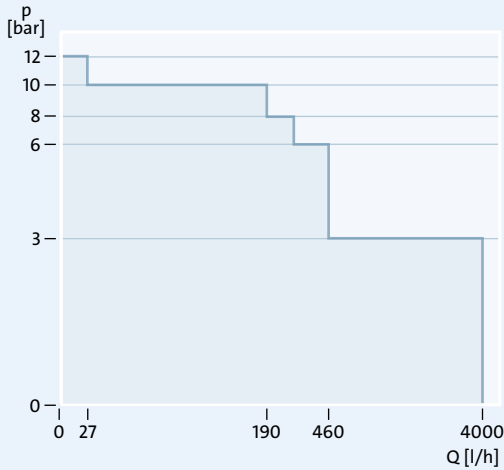

MECHANICAL DIAPHRAGM DOSING PUMPS – DMX

Robust diaphragm-based design with high-quality motors for many dosing applications, they require minimum maintenance and are highly versatile, covering a wide flow range and offering a variety of dosing head sizes, materials and accessories.

BENEFITS

- Dosing from 0.4 up to 2 x 4000 l/h
- Compact design – saves money and space
- Perfect material selection for housing and liquid-wetted parts
- EX/ATEX versions available

TECHNICAL DATA

- Motor size: 0.09 to 2.2 kW
- Flow rate (Q): 0.4 to 2 x 4000 l/h
- Maximum system pressure: 12 bar
- Liquid temperature: Up to +70 °C
- Discharge diameter: DN 8 to DN 65
- Enclosure class: IP 55 or IP 65 (depends on motor)
- Dosing flow variation: below +/- 1.5 %
- Dosing linearity: below +/- 4 %

APPLICATIONS

- DRINKING WATER TREATMENT
- WASTEWATER TREATMENT

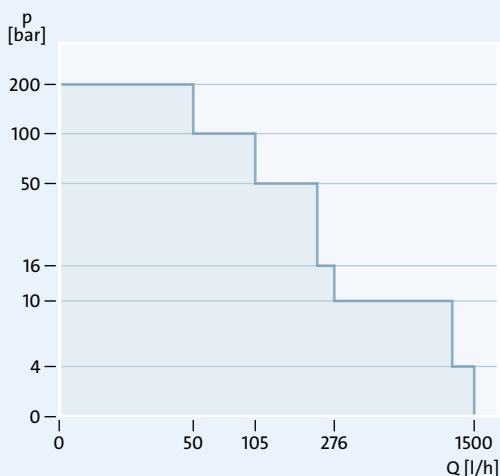

HYDRAULIC PISTON DIAPHRAGM DOSING PUMPS – DMH

Extremely strong, robust pumps for applications requiring a reliable dosing and high-pressure capability for high-pressure applications from 50 up to 200 bar. Highly versatile for a wide flow range and offering a variety of dosing head sizes, materials and accessories.

BENEFITS

- Variable speed via inverter drive and automatic stroke adjustment with servomotor
- EX/ATEX and API 675 versions available
- Very accurate dosing
- Dosing of flammable liquids
- Full PTFE membrane as a standard

TECHNICAL DATA

- Motor size: 0.09 to 2.2 kW
- Flow rate (Q): 0.15 to 2 x 1500 l/h
- Maximum system pressure: 200 bar
- Discharge diameter: DN 4 to DN 32
- Enclosure class: IP 65
- Dosing flow variation: Below +/- 1 % (DMH 28x)
- Dosing flow linearity: Below +/- 1 % (DMH 28x)

APPLICATIONS

- DRINKING WATER TREATMENT
- WASTEWATER TREATMENT



DOSING PUMP ACCESSORIES:

Comprehensive range of accessories covering every requirement when dosing with Grundfos pumps. The range includes:

- DOSING TANKS
- FOOT VALVES & SUCTION LANCES
- MULTIFUNCTION VALVES
- PRESSURE LOADING VALVES
- PRESSURE RELIEF VALVES
- INJECTION UNITS
- HOSES
- CONNECTORS
- CABLES & PLUGS
- HAND MIXERS & ELECTRIC MIXERS
- PULSATION DAMPENERS
- ADAPTORS

BENEFITS

- Save and reliable operation of Grundfos dosing pumps
- Easy system integration

APPLICATIONS

- DRINKING WATER TREATMENT
- WASTEWATER TREATMENT



DOSING TANK AND SKID SYSTEMS – DTS, DSS

The complete chemical feed systems are designed to make dosing technology available as a complete package

DTS: cost-effective dosing stations

Cost-effective dosing tank stations for storing and dosing liquid chemicals. They can be configured by means of a type key and can be flexibly applied to perform various dosing tasks.

Made from high-quality materials, DTS units can be employed universally.

DSS and customized solutions:

Complete panel or cabinet mounted dosing systems, with all necessary pipework, valves and dosing pumps. Standardised packaged systems or custom systems according to customers specifications are available.

BENEFITS

- Complete and ready to use
- Easy installation and commissioning
- Save and reliable operation of Grundfos dosing pumps

TECHNICAL DATA

DTS:

- 6 tank sizes between 60 and 1000l for dosing pumps up to 60 l/h

DSS and customised solutions:

- Cabinet or panel mounted

APPLICATIONS

- DRINKING WATER TREATMENT
- WASTEWATER TREATMENT



FULL-VACUUM CHLORINE GAS DOSING SYSTEMS – VACCUPERM

Gas dosing systems working in accordance with the tried-and-tested full-vacuum principle, which regulates the addition of gaseous chlorine reliably and precisely.

BENEFITS

- Systems for direct installation on chlorine gas cylinders or drums or for installation in header lines
- Precise regulation and dosing of gaseous chlorine
- Complete range of accessories available on request: injectors, automatic changeover units, evaporators, liquid traps, gas warning systems

TECHNICAL DATA

- VGB compact dosing units up to 4 kg/h
- VGA vacuum and dosing regulators up to 20 kg/h
- VGS high performance systems up to 200 kg/h

APPLICATIONS

- **DRINKING WATER TREATMENT**
- **WATER DISTRIBUTION**
- **WASTEWATER TREATMENT**



ON-SITE SODIUM HYPOCHLORITE GENERATORS – SELCOPERM ELECTRO-CHLORINATION

Selcoperm electrolyzers produce sodium hypochlorite electrolytically, directly from a solution of common salt using electricity, offering health and safety benefits for operators and savings on transport and handling.

BENEFITS

- Requires only salt, water and electricity for low-cost generation of your disinfectant
- Generates chlorine on site according to your requirements, saving you transportation and storage costs
- Common salt is non-toxic and easy to store
- Customised solutions on request

SELCOPERM SES 125-2000

TECHNICAL DATA

- Comprises electrolysis cell, degassing column, brine dosing pump and softener
- Salt consumption 4-4.5 kg per kg of Cl₂
- Power consumption 5.5-6.5 kWh (AC) per kg of Cl₂
- Capacities from 110 to 1800g/h
- Sodium hypochlorite concentration 5 – 6.5 g/l

SELCOPERM SES 5000-45000

TECHNICAL DATA

- Capacities from 5 to 45 kg/h
- Salt consumption 3 - 3.5 kg per kg of Cl₂
- Power consumption 5 - 5.4 kWh (AC) per kg of Cl₂
- Sodium hypochlorite concentration 8 – 8.5 g/l

APPLICATIONS

- **DRINKING WATER TREATMENT**
- **WATER DISTRIBUTION**
- **WASTEWATER TREATMENT**



CHLORINE DIOXIDE GENERATORS – OXIPERM

Chlorine dioxide generators that are extremely easy to use, bringing together precise dosing technology, an ideal mixture of components, quick chemical reactions with Maximum conversion rates, and outstanding reliability for effective disinfection.

BENEFITS

- Compact system to be installed on confined spaces
- On-site preparation of chlorine dioxide
- Complete chemical reaction within a minimum of time
- Low operating costs and low consumption of chemicals

OXIPERM PRO OCD 162

TECHNICAL DATA

- Capacities: 5/10/30/60 g/h
- Precursor chemicals: hydrochloric acid (9 mass-%) and sodium chlorite (7.5 mass-%)
- Produced Chlorine Dioxide concentration: 2g/L
- Integrated digital dosing pump for precise dosage of chlorine dioxide

OXIPERM 166 OCG 166

TECHNICAL DATA

- Capacities 0.75 to 10kg/h
- Precursors: chlorine gas and sodium chlorite (24 mass-%)
- Produced Chlorine Dioxide concentration: 3g/L

APPLICATIONS

- DRINKING WATER TREATMENT
- WATER DISTRIBUTION
- WASTEWATER TREATMENT

CHEMICAL PREPARATION SYSTEMS – POLYDOS

The Polydos series are flexible, environmentally friendly and economic dosing and preparation systems that range from one to three chamber installations for preparation of dry or liquid polymers. We can customise the system to match the application.

BENEFITS

- Compact system with a small footprint (compared to a batching unit), fully automatic preparation of polymer incorporating powder handling, polymer mixing and aging stages
- Configured according to the required polymer consumption and the desired concentration
- Our VFI vortex water sensor ensures an exact concentration thanks to a proportional dosing of the polyelectrolyte
- Customisation of systems to match the application
- Additionally to our Polydos unit we can propose powder handling of big-bags solution, granulates/powders/liquids conveying solution. Dosing of prepartate solution can be done with Grundfos Polydos 520 dosing station, and also with additional Polydos P510 post dilution

VARIANTS

- Polydos 412E is a fully automatic three-chamber polyelectrolyte preparation system for concentrated liquid and dry polymers
- Polydos 420E is a fully automatic two-chamber preparation system for liquid concentrated polymer only
- KD 440 is a fully automatic one-chamber preparation system for different products such as aluminium sulphate, polyelectrolyte, lime milk and activated carbon
- Polydos 460E is a fully automatic two-chamber preparation system for liquid concentrated polymer

TECHNICAL DATA

- Capacity range: Up to 10 m³/h of prepared solution with 60 minutes maturation time
- Concentration range: 0.05 to 0.5 %
- Water inlet: Shut-off valve, solenoid valve, pressure reducing valve and flow meter.
- Maximum viscosity of the polymer solution: 2500 mPas
- Ultra-sonic level sensor to enable flow proportional preparation

MATERIAL:

- Dry material feeder and feeding worm, agitator shaft and stainless steel propeller
- Tank material: PPH or SS
- Lines and connections: PVC-U

APPLICATIONS:

- DRINKING WATER TREATMENT
- WASTEWATER TREATMENT



Transforming water, together with Grundfos solutions

We help you adapt more sustainable, intelligent, and optimised water management solutions without ever compromising on system reliability and uptime. Offering an end-to-end portfolio covering the entire water cycle, we deliver the intelligent pumps, systems, and services you need to revolutionise water use in water supply, wastewater, and groundwater & irrigation applications.