

MTR

50/60 Hz IEC

Installation and operating instructions



MTR

English (GB)

Installation and operating instructions 4

中文 (CN)

安装和使用说明书 23

한국어 (KO)

설치 및 작동 지침 41

繁體中文 (TW)

安裝操作手冊 59

Appendix A. 76

Appendix B. 78

Declaration of conformity 79

Declaration of conformity 83

English (GB) Installation and operating instructions

Original installation and operating instructions

Table of contents

1. General information	4
1.1 Hazard statements	4
1.2 Notes	4
2. Product introduction	5
2.1 Intended use	5
2.2 Pumped liquids	5
2.3 Identification.	6
3. Receiving the product.	8
3.1 Transporting the product	8
3.2 Inspecting the product	8
3.3 Lifting the product.	8
4. Installation requirements	9
4.1 Location	9
5. Mechanical installation	9
5.1 Mounting the product	9
6. Electrical connection	12
6.1 Changing the terminal box position	12
6.2 Frequency converter operation	12
7. Starting up the product	13
7.1 Preparing for startup	13
7.2 Venting the product	14
8. Servicing the product	14
8.1 Contaminated products	15
8.2 Service documentation	15
8.3 Maintenance	15
9. Taking the product out of operation.	16
9.1 Taking the product permanently out of operation	16
10. Fault finding the product	17
10.1 The motor does not run when started.	17
10.2 The motor-protective circuit breaker trips immediately when the power supply is switched on	18
10.3 The motor-protective circuit breaker trips occasionally.	18
10.4 The motor-protective circuit breaker has not tripped, but the motor does not run	18
10.5 The pump runs but gives no liquid, or the pump performance is not constant	19
10.6 Leakage from the shaft seal	19
10.7 Noise	19
11. Technical data	20
11.1 Operating conditions	20
11.2 Electrical data	21

11.x MTR 1s/1/3 HS high-speed operation 22

12. Disposing of the product 22

1. General information



Read this document before you install the product. Installation and operation must comply with local regulations and accepted codes of good practice.

1.1 Hazard statements

The symbols and hazard statements below may appear in Grundfos installation and operating instructions, safety instructions and service instructions.



DANGER

Indicates a hazardous situation which, if not avoided, will result in death or serious personal injury.



WARNING

Indicates a hazardous situation which, if not avoided, could result in death or serious personal injury.



CAUTION

Indicates a hazardous situation which, if not avoided, could result in minor or moderate personal injury.

The hazard statements are structured in the following way:

SIGNAL WORD



Description of the hazard

Consequence of ignoring the warning

- Action to avoid the hazard.

1.2 Notes

The symbols and notes below may appear in Grundfos installation and operating instructions, safety instructions and service instructions.



Observe these instructions for explosion-proof products.



A blue or grey circle with a white graphical symbol indicates that an action must be taken.



A red or grey circle with a diagonal bar, possibly with a black graphical symbol, indicates that an action must not be taken or must be stopped.



If these instructions are not observed, it may result in malfunction or damage to the equipment.



Tips and advice that make the work easier.

2. Product introduction

These installation and operating instructions describe Grundfos MTR model A and model C pumps fitted with 50 Hz or 60 Hz IEC motors.

MTR pumps are vertical multistage centrifugal pumps designed to be mounted on top of tanks with the chamber stack immersed in the pumped liquid. To meet specific depths of tanks or containers, the immersed length of the pump can be varied using empty chambers.

The product consists of a motor and a pump unit.

Material versions for MTR

- A-version with wetted parts of cast iron and stainless steel.
- I-version with wetted parts of stainless steel grade EN/DIN 1.4301.
- N-version with wetted parts of stainless steel grade EN/DIN 1.4401.

2.1 Intended use

The tank-mounted multistage centrifugal pumps are designed for the following applications:

- liquid transfer in machine tools
- condensate transfer
- liquid transfer in industrial washing machines
- pressure boosting of cold or hot clean liquids
- similar applications.

2.2 Pumped liquids

The product is suitable for pumping clean, thin, non-aggressive and non-explosive liquids without solid particles or fibres. The liquid must not attack the pump materials chemically and mechanically.

When pumping liquids with a density and/or viscosity higher than that of water, use motors with correspondingly higher outputs, if required.

Whether a pump is suitable for a particular liquid depends on a number of factors of which the most important are the chloride content, pH-value, temperature and content of chemicals and oils.



Aggressive liquids may attack or dissolve the protective oxide film of the stainless steel and thus cause corrosion.

2.3 Identification

2.3.1 Nameplate for MTR, MTRE

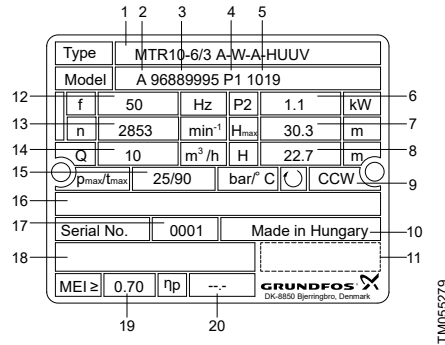

Example of a pump nameplate

Pos.	Description
1	Type designation
2	Model
3	Product number
4	Production code
5	Production year and week (YYWW)
6	Power at rated flow rate and rated speed (P2)
7	Head against closed valve
8	Head at rated flow rate
9	Direction of rotation: CCW: Counterclockwise CW: Clockwise
10	Country of origin
11	Approval marks
12	Frequency
13	Rated speed
14	Rated flow rate
15	Maximum system pressure/maximum liquid temperature
16	Technical file number (stated if the pump is ATEX-classified) or customer-specific information

Pos.	Description
17	Serial number (stated if the pump is ATEX-classified)
18	ATEX category (stated if the pump is ATEX-classified)
19	Minimum efficiency index
20	Hydraulic pump efficiency at rated flow rate

Related information

3.2 Inspecting the product

2.3.2 Type key for MTR, MTRE

Example of a pump type key.

MTRE 32-2/1-1 A-F-A-HUUV

Code	Explanation
MTR	Pump type
E	Pump with integrated frequency converter
32	Rated flow rate [m³/h]
2	Number of chambers
1	Number of impellers
1	Number of impellers with reduced diameter
A	Code for pump version
F	Code for pipe connection
A	Code for materials
	Code for shaft seal:
H	• Shaft seal type designation
U	• Seal face material (rotating seal face)
U	• Seal face material (stationary seal face)
V	• Secondary seal material (rubber parts)

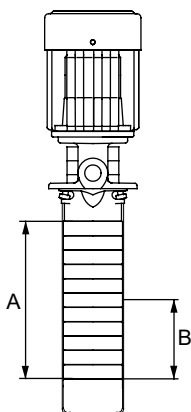

TM014993

Number of chambers (A) and number of impellers (B)

Related information

[5.1.2 Horizontal mounting of version H pumps](#)

2.3.2.1 Key to codes

Note that each individual pump type is not available in all variants.

Code	Description
Pump version	
A	Basic version
B	Oversize motor
C	Inlet pipe
D	Drainage back to tank
E	Pump with certificate/approval
F	120 °C version
H	Horizontal version
HS	High pressure
J	E-pump with different maximum speed
L	With extension pipe
P	Undersize motor
T	Double oversize
X	Special version
Pipe connection	
F	DIN flange
G	ANSI flange
J	JIS flange

Code	Description
M	Square flange
W	Internal thread
WB	NPT internal thread
X	Special version
Materials	
A	Basic version
I	Wetted parts EN/DIN 1.4301 / AISI 304
N	Wetted parts EN/DIN 1.4401 / AISI 316
X	Special version
Shaft seal type designation	
A	O-ring seal with fixed seal driver
B	Bellows seal, rubber
C	O-ring seal with spring as seal driver
H	Balanced cartridge seal with O-ring
R	O-ring seal, type A, with reduced seal faces
Seal face material (rotating and stationary seal face)	
A	Carbon, metal-impregnated
B	Carbon, synthetic resin-impregnated
Q	Silicon carbide
U	Cemented tungsten carbide
V	Metal oxides, ceramic
Secondary seal material (rubber parts)	
E	EPDM
F	FXM (Fluoraz [®])
K	FFKM (Kalrez [®])
P	NBR
V	FKM (Viton [®])

3. Receiving the product

3.1 Transporting the product



WARNING

Falling objects

Death or serious personal injury

- Secure the product during transport to prevent it from tilting or falling down.



CAUTION

Back injury

Minor or moderate personal injury

- Use lifting equipment.



CAUTION

Crushing of feet

Minor or moderate personal injury

- Wear safety shoes when moving the product.

3.2 Inspecting the product

Before installing the product, do the following:

1. Check that the product is as ordered.
2. Check that no visible parts have been damaged.
3. If parts are damaged or missing, contact your local Grundfos sales company.

Related information

[2.3.1 Nameplate for MTR, MTR E](#)

3.3 Lifting the product

WARNING

Falling objects

Death or serious personal injury



- Do not use the motor eyebolts to lift the entire product if the pump is fitted with a motor of another make than Grundfos MG and MGE.

- Follow the lifting instructions.
- Use lifting equipment which is approved for the weight of the product.
- Persons must keep a safe distance to the product during lifting operations.
- Wear personal protective equipment.



Note that typically the centre of gravity of the pump is close to the motor.

3.3.1 Lifting the product in vertical position

To lift the entire pump with motor, follow the below instructions for the size and type of motor fitted on your pump. Valid for motors up to 45 kW.

Pumps with motor sizes 0.37 - 5.5 kW

Valid for Grundfos MG, MGE and for all types of sourced motors.

- Lift the product in the motor flange by means of straps or similar lifting equipment.

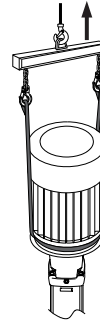

TM068597

Pumps with motor sizes 7.5 - 22 kW

Valid for Grundfos MG and MGE motors only.

- Lift the product by means of the motor eyebolts.

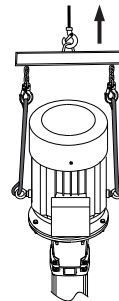

TM068598

Pumps with motor sizes 7.5 - 45 kW

Valid for all types of sourced motors. Not valid for Grundfos MG and MGE.

- Lift the product by means of the lifting brackets on the motor flange.

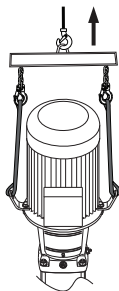

4. Installation requirements

4.1 Location

The product is intended for indoor use. If you install the product outdoors, follow the requirements in the section on outdoor installation.

Related information

[4.1.1 Outdoor installation](#)

4.1.1 Outdoor installation

When the pump is installed outdoors, we recommend that you provide the motor with a rain cover. We also recommend that you open one of the drain holes in the motor flange.

Related information

[4.1 Location](#)

5. Mechanical installation

WARNING

Moving parts

Death or serious personal injury



- Tighten the coupling screws to the correct torque.
- Install the coupling guards securely to the pump with the screws intended for this purpose.

CAUTION

Hot surface

Minor or moderate personal injury



- The product must be installed so that persons cannot accidentally come into contact with the hot surface of the motor.

TMD088599

5.1 Mounting the product

The pump is designed for tank mounting in vertical position. For horizontal mounting, see the section on MTR version H.

The pump is positioned in a hole cut into the tank and is secured to the tank by four hexagon head screws through the holes in the mounting flange.

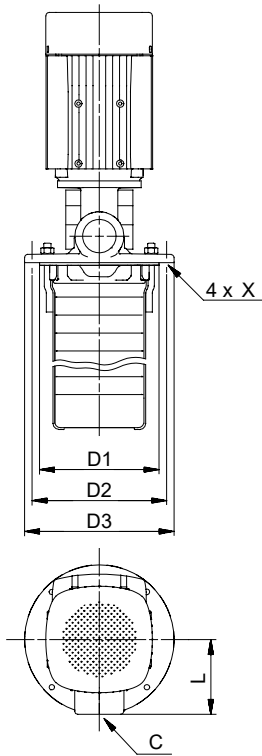

Vertical installation

Mounting flange dimensions:

Pump type	D1*	D2*	D3*	L*	C	X*
MTR 1s, 1, 2, 3, 4, 5, 8 version A	140	160	180	100	Rp 1 1/4 G 1 1/4	Ø7.5
MTR 1s, 1, 2, 3, 4, 5, 8 version I, N	140	160	180	100	Rp 1 1/4 G 1 1/4	Ø9
MTR 10, 15, 20	200	225	250	125	Rp 2 G 2	Ø9
MTR 32	190	220	250	150	DN 65	Ø12
MTR 45, 64	240	265	290	165	DN 80	Ø12

* The numbers are indicated in millimetres.

5.1.1 Inlet conditions

The bottom of the pump strainer must be at least 25 mm above the bottom of the tank.

The pumps are designed to provide full performance to a level of A mm above the bottom of the strainer.

At a liquid level between A and B mm above the bottom of the strainer, the built-in priming screw protects the pump against dry running.

MTR 32, 45 and 64 pumps have no priming screw.

Pump type	A [mm]	B [mm]
MTR 1s, 1, 2, 3, 4, 5, 8	41	28
MTR 10, 15, 20	50	25
MTR 32, 45, 64	70	-

The distance between the flange and the liquid level must be minimum 25 mm.

The distance between the pump and the tank bottom must be minimum 25 mm.

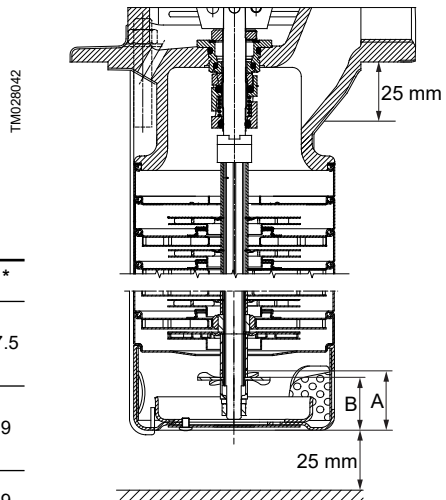

MTR 1s, 1, 2, 3, 4, 5, 8

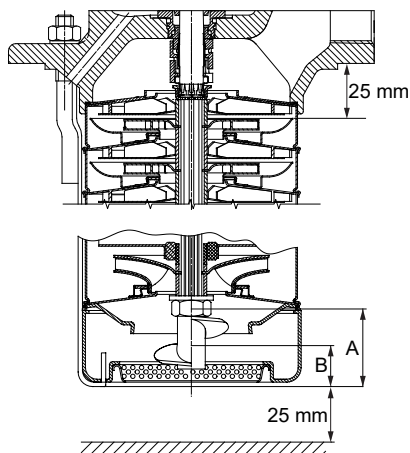

MTR 10, 15, 20

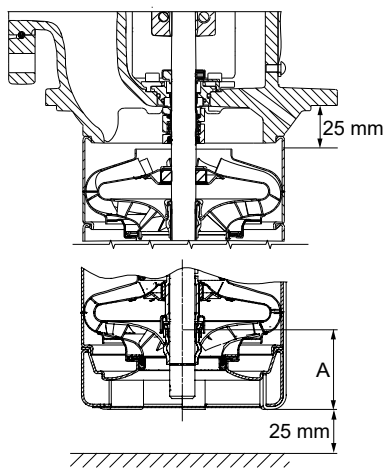

MTR 32, 45, 64

5.1.2 Horizontal mounting of version H pumps

MTR, MTRE version H pumps are suitable for horizontal mounting. The pump head is fitted with a plug in the drain hole.

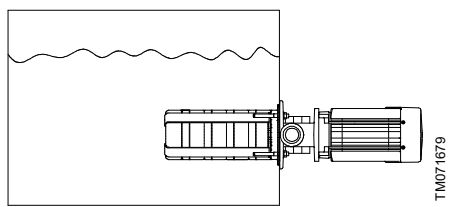

Horizontally installed MTR version H pump

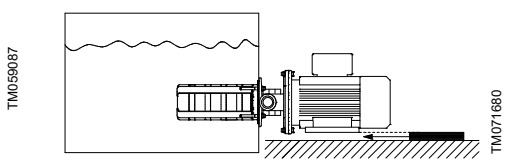

Horizontally installed MTR version H pump with foot support

- Check the pump nameplate to confirm that the pump is suitable for horizontal mounting. The code for the pump version must be H. See the section on type key.
- Check if the motor needs support. Motors from 5.5 kW and up have a foot and must be supported.
- Fit a sealing gasket or similar between the pump flange and the tank to prevent leakage.

! Drain the tank before changing the shaft seal.

! Pump version H for horizontal mounting is available for MTR, MTRE 1s, 1, 2, 3, 4, 5, 8, 10, 15 and 20. MTR, MTRE 32, 45, 64 pumps must be installed in a vertical position.

Related information

[2.3.2 Type key for MTR, MTRE](#)

6. Electrical connection

WARNING

Electric shock

Death or serious personal injury



- Switch off the power supply before you start any work on the product. Make sure that the power supply cannot be switched on accidentally.
- Connect the product to an external main switch close to the product and to a motor-protective circuit breaker or a CUE frequency converter. Make sure that you can lock the main switch in OFF position (isolated). Type and requirements as specified in EN 60204-1, 5.3.2.



All electrical connections must be carried out by a qualified electrician in accordance with local regulations.



Check that the supply voltage and frequency correspond to the values stated on the nameplate.



Carry out the electrical connection as shown in the wiring diagram located inside the terminal box cover.

Single-phase Grundfos motors incorporate a thermal switch and require no additional motor protection.

Three-phase motors must be connected to a motor-protective circuit breaker.

6.1 Changing the terminal box position

WARNING

Electric shock

Death or serious personal injury



- Switch off the power supply before you start any work on the product. Make sure that the power supply cannot be switched on accidentally.

The terminal box can be turned to four positions in 90° steps.

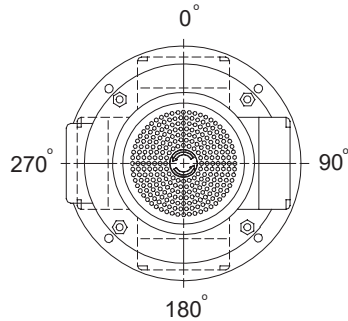

TMD04257

Terminal box positions, top view

Follow this procedure to change the terminal box position:

1. If necessary, remove the coupling guards. Do not remove the coupling.
2. Remove the bolts securing the motor to the pump.
3. Turn the motor to the required position.
4. Refit and tighten the bolts.
5. Refit the coupling guards.

6.2 Frequency converter operation

You can use three-phase motors for frequency converter operation following the conditions below. This section applies to motors defined in IEC 60034.

Related information

10.7 Noise

6.2.1 General conditions

Protect all motors used with frequency converters against voltage peaks and dU/dt according to IEC 60034-17. Grundfos recommends that you use insulated bearings for motors from frame size 225 (45 kW/2-pole, 30 kW/4-pole and 22 kW/6-pole).

6.2.2 Mains-voltage-dependent conditions

200-240 V

No output filters are required for frequency-converter-operated motors with mains voltages up to 240 V.

380-500 V

For frequency-converter-operated motors with a power cable length less than 25 m and a mains supply up to 460 V, no additional motor protection against voltage peaks is required. For frequency-converter-operated motors with a power cable length of more than 25 m or a mains supply higher than 460 V, sine-wave filters are required.

500 V and higher

Always use sine-wave filters for motors marked with 500 V or higher voltages.



Motors with reinforced insulation can be supplied as an option. These motors are according to IEC 60034-25, and therefore there is no need for sine-wave filters. This does not eliminate the requirement for insulated bearings from frame size 225.

Exception

- Protect Grundfos motors types MG 71 and MG 80 (up to 1.1 kW/2-pole and up to 0.75 kW/4-pole) for supply voltages up to and including 440 V without phase insulation against voltage peaks above 650 V between the supply terminals.
- If you use MG 71 and MG 80 without phase insulation for input voltages above 240 V, it requires that you use sine-wave filters at the output of the frequency converter.

MG 71 and MG 80 with phase insulation for use with variable frequency drives are available as standard products.

Motors supplied by Grundfos

You can connect all three-phase MG motors with phase insulation to a frequency converter.

Other motor makes than those supplied by Grundfos

Contact Grundfos or the motor manufacturer.

6.2.3 Phase insulation, MG 71 and 80

MG motors, frame sizes 71 and 80, do not have phase insulation as standard. The motors are not suitable for frequency converter operation as they are not protected against the voltage peaks caused by the frequency converter operation. Only motors with a rated voltage equal to 460 V or above have phase insulation.



Frequency converter operation of MG motors without phase insulation will cause damage to the motor.

We recommend that you protect all other motors against voltage peaks higher than 1200 V by 2000 V/µsec.

You can eliminate the above disturbances, that is both increased acoustic noise and detrimental voltage peaks, by fitting an LC filter between the frequency converter and the motor.

For further information, contact the frequency converter or motor supplier.

7. Starting up the product

CAUTION

Too high pressure and leakage

Minor or moderate personal injury



- Do not run the product against a closed outlet valve for more than approximately 5 minutes.

7.1 Preparing for startup

- Make sure that all pipe connections are tight, stress-free and sealed.
- Make sure that the pump is immersed to the recommended level and that it is partly filled with liquid.
- Make sure that the liquid level in the tank is above the minimum immersion depth.
- Make sure that the strainer or chip trays are not blocked by impurities.
- Make sure that all safety equipment is installed and tested for functionality.

7.2 Venting the product



Make sure that the pump is immersed and partly filled with liquid before starting it.

1. Close the isolating valve on the outlet side of the pump and open the isolating valve on the inlet side.
2. If the pump is fitted with a vent valve, open the valve (pos. 1).

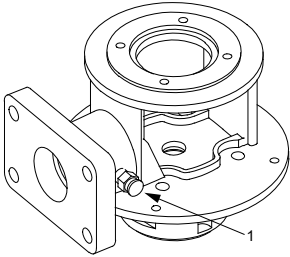

3. See the correct direction of rotation of the pump on the motor fan cover or on the coupling guard.

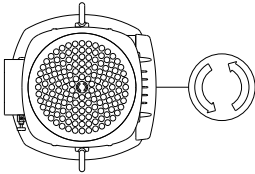

4. Start the pump and check the direction of rotation. If the direction of rotation is wrong, interchange two phases to the motor in the power supply.
5. Open the isolating valve on the outlet side of the pump a little.
6. If the pump is fitted with a vent valve, close the valve when a steady flow of liquid runs out of it.
7. Completely open the isolating valve on the outlet side of the pump.

The pump has now been vented and is ready for operation.

TM016428

TM076491

8. Servicing the product

WARNING

Electric shock

Death or serious personal injury



- Switch off the power supply before you start any work on the product. Make sure that the power supply cannot be switched on accidentally.

WARNING

Moving parts

Death or serious personal injury



- Tighten the coupling screws to the correct torque.
- Install the coupling guards securely to the pump with the screws intended for this purpose.

WARNING

Falling objects

Death or serious personal injury



- Do not use the motor eyebolts to lift the entire product if the pump is fitted with a motor of another make than Grundfos MG and MGE.
- Follow the lifting instructions.
- Use lifting equipment which is approved for the weight of the product.
- Persons must keep a safe distance to the product during lifting operations.
- Wear personal protective equipment.

CAUTION

Corrosive liquids

Minor or moderate personal injury



- Wear personal protective equipment.

CAUTION

Toxic liquids

Minor or moderate personal injury



- Wear personal protective equipment.

CAUTION

Hot or cold liquid

Minor or moderate personal injury



- Wear personal protective equipment.





CAUTION
Hot or cold surface

Minor or moderate personal injury



- Make sure that no one can accidentally come into contact with hot or cold surfaces.

8.1 Contaminated products

CAUTION
Biological hazard

Minor or moderate personal injury



- Flush the pump thoroughly with clean water and rinse the pump parts in water after dismantling.

The product will be classified as contaminated if it has been used for a liquid which is injurious to health or toxic. If you request Grundfos to service the product, contact Grundfos with details about the pumped liquid before returning the product for service. Otherwise, Grundfos can refuse to accept the product for service. Any application for service must include details about the pumped liquid.

Clean the product in the best possible way before you return it. Costs of returning the product are to be paid by the customer.

Related information

[9.1 Taking the product permanently out of operation](#)

8.2 Service documentation

Pumps

Service instructions and service kits are available in Grundfos Product Center at <http://product-selection.grundfos.com>.

Grundfos motors

Service documentation is available in Grundfos Product Center at <http://product-selection.grundfos.com>. If you have any questions, please contact the nearest Grundfos company or service workshop.

Sourced motors of other makes than Grundfos

Contact the motor manufacturer.

8.3 Maintenance

8.3.1 Periodic checks

Make the following checks at regular intervals, depending on the conditions and time of operation.

- Check the quantity of liquid and the operating pressure.
- Check that there are no leaks.
- Check that the motor is not overheating.

- Check the tripping function of the motor-protective circuit breaker.
- Check that all controls are operating satisfactorily.

If the above checks do not reveal any abnormal operating details, no further checks are necessary. Should any faults be found, check the symptoms according to the section on fault finding the product.

Related information

[10. Fault finding the product](#)

8.3.2 Pump

Pump bearings and shaft seal are maintenance-free.

8.3.3 Filters

Clean chip trays and filters at regular intervals to ensure a correct flow of liquid. This will also increase the life of the pump.

8.3.4 Motor bearings

Motors not fitted with grease nipples are maintenance-free.

Motors fitted with grease nipples must be lubricated with a high-temperature, lithium-based grease. See the instructions on the fan cover.

In the case of seasonal operation where the motor is idle for more than 6 months of the year, grease the motor when you take the pump out of operation.

Depending on the ambient temperature, replace or lubricate the motor bearings according to the tables below.

- The tables apply to 2-pole motors.
- Intervals for 4-pole motors are twice as long as those for 2-pole motors.

If the ambient temperature is lower than 40 °C, replace or lubricate the bearings at the same intervals as for 40 °C.

Intervals for 2-pole motors:

Motor size [kW]	Bearing replacement interval [operating hours*]				
	40 °C	45 °C	50 °C	55 °C	60 °C
0.37 - 0.75	18000	-	-	-	-
1.1 - 7.5	20000	15500	12500	10000	750

* The number of operating hours stated for bearing replacement are guidelines only.

Motor size [kW]	Lubrication interval [operating hours]				
	40 °C	45 °C	50 °C	55 °C	60 °C
11 - 18.5	4500	3400	2500	1700	1100
22	4000	3100	2300	1500	1000
30-55	4000	3000	2000	1500	-
75	2000	1500	1000	500	-

8.3.5 Coupling adjustment

For adjustment of the coupling in MTR 1s to 20, see the drawings in the appendix.

For adjustment of the coupling in MTR 32, 45, 64, see the drawings in the appendix.

Related information

- A.1. [Coupling adjustment of MTR 1s to 20](#)
- A.2. [Coupling adjustment of MTR 32, 45, 64](#)

9. Taking the product out of operation

9.1 Taking the product permanently out of operation

WARNING

Electric shock

Death or serious personal injury



- Switch off the power supply before you start any work on the product. Make sure that the power supply cannot be switched on accidentally.

WARNING

Falling objects

Death or serious personal injury



- Do not use the motor eyebolts to lift the entire product if the pump is fitted with a motor of another make than Grundfos MG and MGE.
- Follow the lifting instructions.
- Use lifting equipment which is approved for the weight of the product.
- Persons must keep a safe distance to the product during lifting operations.
- Wear personal protective equipment.

CAUTION

Corrosive liquids

Minor or moderate personal injury



- Wear personal protective equipment.



CAUTION

Toxic liquids

Minor or moderate personal injury

- Wear personal protective equipment.



CAUTION

Hot or cold liquid

Minor or moderate personal injury

- Wear personal protective equipment.



CAUTION

Hot or cold surface

Minor or moderate personal injury

- Make sure that no one can accidentally come into contact with hot or cold surfaces.





The product will be classified as contaminated if it has been used for a liquid which is injurious to health or toxic.

Related information

- [8.1 Contaminated products](#)

10. Fault finding the product

-  **WARNING**
Electric shock
 Death or serious personal injury
- Switch off the power supply before you start any work on the product. Make sure that the power supply cannot be switched on accidentally.

-  **WARNING**
Moving parts
 Death or serious personal injury
- Tighten the coupling screws to the correct torque.
 - Install the coupling guards securely to the pump with the screws intended for this purpose.

-  **CAUTION**
Corrosive liquids
 Minor or moderate personal injury
- Wear personal protective equipment.

-  **CAUTION**
Toxic liquids
 Minor or moderate personal injury
- Wear personal protective equipment.

-  **CAUTION**
Hot or cold liquid
 Minor or moderate personal injury
- Wear personal protective equipment.

-  **CAUTION**
Hot or cold surface
 Minor or moderate personal injury
- Make sure that no one can accidentally come into contact with hot or cold surfaces.

Related information

[8.3.1 Periodic checks](#)

10.1 The motor does not run when started.

Cause	Remedy
Power supply failure.	Connect the power supply.
One or more fuses are blown.	Replace the fuses.
The motor-protective circuit breaker has tripped.	Reactivate the motor-protective circuit breaker.
The thermal protection has tripped.	Reactivate the thermal protection.
The main contacts in the motor-protective circuit breaker are not making contact, or the coil is faulty.	Replace the contacts or the magnetic coil.
The control circuit is defective.	Repair the control circuit.
The motor is defective.	Replace the motor.

10.2 The motor-protective circuit breaker trips immediately when the power supply is switched on

Cause	Remedy
A fuse is blown or the motor-protective circuit breaker has tripped.	Replace the fuse or reset the motor-protective circuit breaker.
The contacts in the motor-protective circuit breaker are faulty.	Replace the motor-protective circuit breaker contacts.
The cable connection is loose or faulty.	Fasten or replace the cable connection.
The motor winding is defective.	Replace the motor.
The pump is mechanically blocked.	Remove the mechanical blocking of the pump.
The overload setting for the motor-protective circuit breaker is too low.	Set the motor-protective circuit breaker correctly.

10.3 The motor-protective circuit breaker trips occasionally

Cause	Remedy
The overload setting for the motor-protective circuit breaker is too low.	Set the motor-protective circuit breaker correctly.
The voltage is low at peak times.	Ensure a constant power supply.

10.4 The motor-protective circuit breaker has not tripped, but the motor does not run

Cause	Remedy
Power supply failure.	Connect the power supply.
One or more fuses are blown.	Replace the fuses.
The thermal protection has tripped.	Reactivate the thermal protection.
The main contacts in the motor-protective circuit breaker are not making contact, or the coil is faulty.	Replace the contacts or the magnetic coil.
The control circuit is defective.	Repair the control circuit.

10.5 The pump runs but gives no liquid, or the pump performance is not constant

Cause	Remedy
The pump strainer is partly blocked by impurities.	Clean the strainer.
The liquid level in the tank is too low.	Increase the liquid level.
The pump draws in air.	Check the inlet conditions.

10.6 Leakage from the shaft seal

Cause	Remedy
The shaft seal is defective.	Replace the shaft seal.

10.7 Noise

Cause	Remedy
Cavitation.	Check the inlet conditions.
The pump does not rotate freely because of an incorrect pump shaft position (frictional resistance).	Adjust the pump shaft.
Frequency converter operation.	<p>Frequency converter operation may cause increased acoustic noise from the motor. Make sure to protect the motor against voltage peaks and dU/dt according to IEC 60034-17.</p> <p>For noise-critical applications, fit an output filter between the motor and the frequency converter to reduce the voltage peaks. For particularly noise-critical applications, fit a sinusoidal filter.</p> <p>See Grundfos recommendations in the section on frequency converter operation.</p>

Related information

[6.2 Frequency converter operation](#)

11. Technical data

11.1 Operating conditions

11.1.1 Operating pressure and liquid temperature

Pump type	MTR
Minimum liquid temperature [°C]	-10
Maximum liquid temperature [°C]	90 (120 [*])
Maximum operating pressure [bar]	25

* Applies to MTR pump version F.

The maximum liquid temperature depends on the shaft seal type and the pump type. The maximum liquid temperature is stated on the pump nameplate.

11.1.2 Maximum permissible operating pressure and liquid temperature for the shaft seal

11.1.2.1 Shaft seals for MTR, MTR E

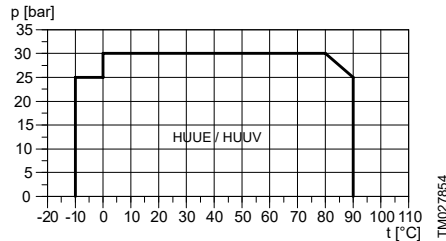

Maximum permissible operating pressure and liquid temperature for the shaft seal.

Shaft seal [*]	Description	Temperature range [°C]
HUUE/ HUUV	O-ring seal (cartridge type), balanced, tungsten carbide/ tungsten carbide, HUUE/ HUUV (EPDM/FKM)	-10 to +90

* Other shaft seals on request.

11.1.3 Minimum flow rate

The curve shows the minimum flow rate as a percentage of the rated flow rate in relation to the liquid temperature.

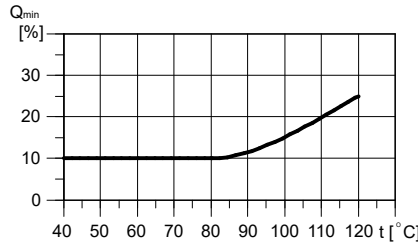

Minimum flow rate in percentage of the rated flow rate



Do not use the pump at flow rates below the minimum flow rate. The motor risks overheating.

11.1.4 Ambient temperature and altitude

The table shows the maximum permissible ambient temperature at full load and the maximum permissible installation altitude above sea level at full load.

Motor power [kW]	Motor make	Max. ambient temperature [°C]	Max. altitude [m]
0.06 - 0.18	Siemens	40	1000
0.25 - 0.55	Grundfos MG	40	1000
0.75 - 2.2	Grundfos MG	60	3500
3.0 - 4.5	Siemens	55	2750

Motor output derating factors

If the ambient temperature exceeds the maximum permissible temperature value or the pump is installed at an altitude exceeding the maximum permissible altitude value, the motor must not be fully loaded due to the risk of overheating. Overheating may result from excessive ambient temperatures or the low density and consequently low cooling effect of the air.

In such cases, it may be necessary to use a motor with a higher rated output.

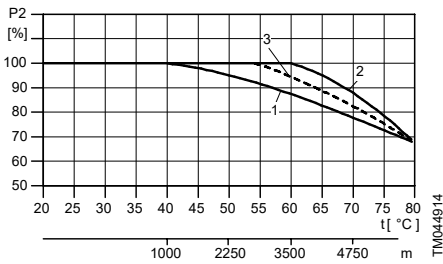

Motor output (P2) in relation to ambient temperature and altitude

Curve	Motor power [kW]	Motor make	Motor efficiency class
1	0.06 - 0.18	Siemens	IE3
1	0.25 - 0.55	Grundfos MG	IE3
2	0.75 - 22	Grundfos MG	IE3
3	30-45	Siemens	IE3

Example of maximum motor load

Pump with a 2.2 kW IE3 motor (derating curve 2):

- If this pump is installed 4750 m above sea level, the motor must not be loaded more than 88 % of the rated output.
- At an ambient temperature of 75 °C, the motor must not be loaded more than 78 % of the rated output.
- If the pump is installed 4750 m above sea level at an ambient temperature of 75 °C, multiply the derating factors. The motor must not be loaded more than 88 % × 78 % = 68.6 % of the rated output.



If the motor load is not reduced in case the ambient temperature or installation altitude is exceeded, the motor life will be limited, and the warranty is void.

11.1.5 Maximum number of starts

Motor power [kW]	Recommended maximum number of starts per hour
0.06 - 0.18	100
0.25 - 2.2	250
3-4	100
5.5 - 11	50
15-22	40
30-45	8

11.1.6 Sound pressure level

The table below shows airborne noise emitted by pumps with motors fitted by Grundfos.

Motor power [kW]	50 Hz	60 Hz
	ISO 3743-2 / ISO 1680	ISO 3743-2 / ISO 1680
	L _{pA} [dB(A)]	L _{pA} [dB(A)]
0.37	50	55
0.55	50	53
0.75	50	54
1.1	52	57
1.5	54	59
2.2	54	59
3.0	55	60
4.0	62	66
5.5	60	65
7.5	60	65
11	60	65
15	60	65
18.5	60	65
22	66	70
30	67	75
37	67	75
45	67.5	75

11.2 Electrical data

See the motor nameplate.

11.3 MTRE 1s/1/3 HS high-speed operation

11.3.1 Shaft seals for MTRE HS

Special operating ranges apply to these pump types at high-speed operation:

- MTRE 1s-XX/19 HS
- MTRE 1-XX/19 HS
- MTRE 3-XX/19 HS

At high-speed operation, 5400 rpm, MTRE 1s/1/3 HS pumps can operate in range 3.

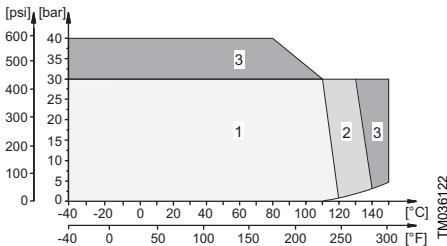

Three different operating ranges for the HUUE/HUUV cartridge shaft seals fitted to MTRE HS pumps.

Pos.	Description
1	Optimum operating range with the longest life of the shaft seal.
2	Risk of periodic noise in connection with start-up and variation in pressure and temperature.
3	Outer operating range where the life of the shaft seal may be reduced. Grundfos recommends a service check every 8000-12,000 hours for operating range 3.

The standard seal in MTR, MTRE pumps is an HUUV seal, which is applicable in oil-containing liquids within the whole operating range. However, the maximum temperature for the pump is 90 °C.

Pump type	MTRE 1s/1/3 HS
Minimum liquid temperature [°C]	-10
Maximum liquid temperature [°C]	+90
Maximum operating pressure [bar]	38

11.3.2 Sound pressure levels for MTRE 1s/1/3 HS

The table below shows airborne noise emitted by MTRE 1s/1/3 HS pumps at high-speed operation.

Motor power [kW]	Maximum motor speed [rpm]	100 Hz L _{pA} [dB(A)]
4	5400	74
5.5	5300	74
7.5	5100	79

12. Disposing of the product

This product or parts of it must be disposed of in an environmentally sound way.

1. Use the public or private waste collection service.
2. If this is not possible, contact the nearest Grundfos company or service workshop.



The crossed-out wheeled bin symbol on a product means that it must be disposed of separately from household waste. When a product marked with this symbol reaches its end of life, take it to a collection point designated by the local waste disposal authorities. The separate collection and recycling of such products will help protect the environment and human health.

See also end-of-life information at www.grundfos.com/product-recycling.

Appendix A

A.1. Coupling adjustment of MTR 1s to 20

>

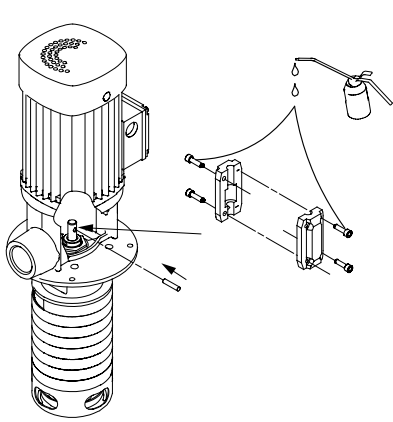

TM028050

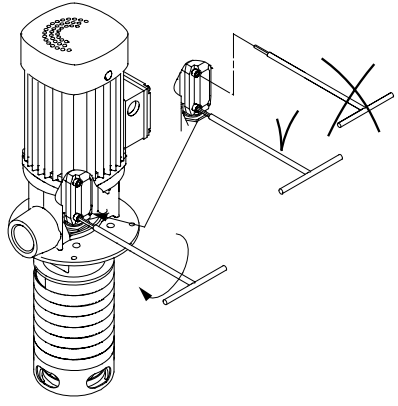

TM028051

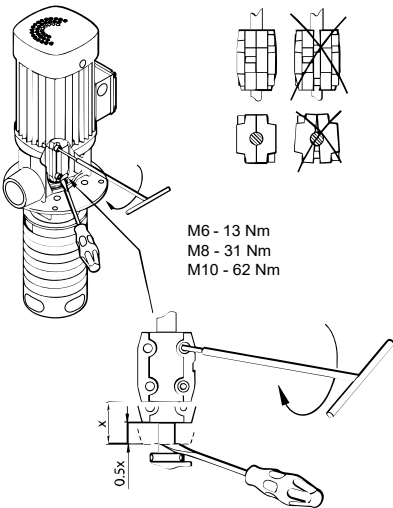

TM079040

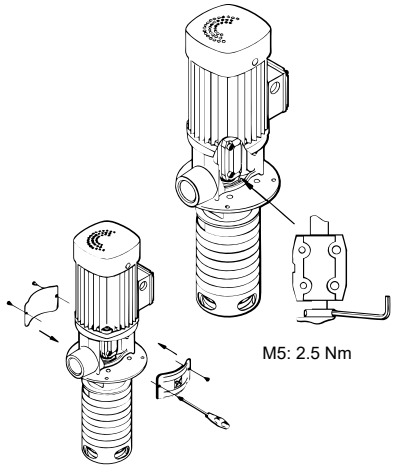

TM079041

Related information

- 8.3.5 Coupling adjustment
- 8.3.5 耦合調整
- 8.3.5 커플링 조정
- 8.3.5 聯軸器調整

A.2. Coupling adjustment of MTR 32, 45, 64

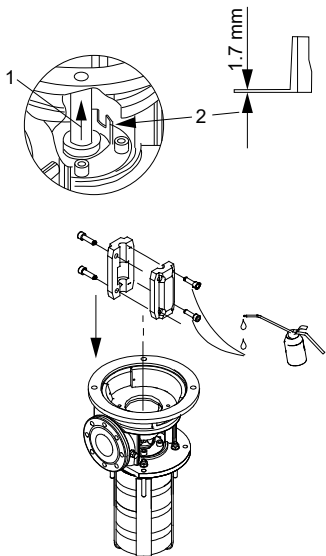

TM079042

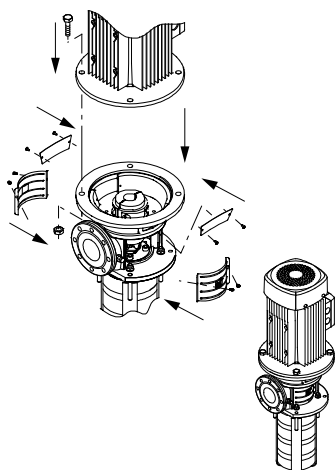

TM019786

Related information

- 8.3.5 耦合调整
- 8.3.5 커플링 조정
- 8.3.5 聯軸器調整
- 8.3.5 Coupling adjustment

Appendix B

B.1. China RoHS, table A

产品中有害物质的名称及含量

部件名称	有害物质					
	铅 (Pb)	汞 (Hg)	镉 (Cd)	六价铬 (Cr6+)	多溴联苯 (PBB)	多溴联苯醚 (PBDE)
泵壳	X	0	0	0	0	0
紧固件	X	0	0	0	0	0
管件	X	0	0	0	0	0
定子	X	0	0	0	0	0
转子	X	0	0	0	0	0

本表格依据 SJ/T 11364 的规定编制

O: 表示该有害物质在该部件所有均质材料中的含量均在 GB/T 26572 规定的限量要求以下。
X: 表示该有害物质至少在该部件的某一均质材料中的含量超出 GB/T 26572 该规定的限量要求。

 该产品环保使用期限为 10 年，标识如左图所示。
此环保期限只适用于产品在安装与使用说明书中所规定的条件下工作

Declaration of conformity

GB: EC/EU declaration of conformity

We, Grundfos, declare under our sole responsibility that the products MTR, SPK, MTH, MTC, MTS, to which the declaration below relates, are in conformity with the Council Directives listed below on the approximation of the laws of the EC/EU member states.

CZ: Prohlášení o shodě EU

My firma Grundfos prohlašujeme na svou plnou odpovědnost, že výrobky MTR, SPK, MTH, MTC, MTS, na které se toto prohlášení vztahuje, jsou v souladu s níže uvedenými ustanoveními směrnice Rady pro sblížení právních předpisů členských států Evropského společenství.

DK: EF-/EU-overensstemmelseserklæring

Vi, Grundfos, erklærer under ansvar at produkterne MTR, SPK, MTH, MTC, MTS som erklæringen nedenfor omhandler, er i overensstemmelse med Rådets direktiver der er nævnt nedenfor, om indbyrdes tilnærmelse til EF-/EU-medlemsstaternes lovgivning.

ES: Declaración de conformidad de la CE/UE

Grundfos declara, bajo su exclusiva responsabilidad, que los productos MTR, SPK, MTH, MTC, MTS a los que hace referencia la siguiente declaración cumplen lo establecido por las siguientes Directivas del Consejo sobre la aproximación de las legislaciones de los Estados miembros de la CE/UE.

FR: Déclaration de conformité CE/UE

Nous, Grundfos, déclarons sous notre seule responsabilité, que les produits MTR, SPK, MTH, MTC, MTS, auxquels se réfère cette déclaration, sont conformes aux Directives du Conseil concernant le rapprochement des législations des États membres CE/UE relatives aux normes énoncées ci-dessous.

HR: EC/EU deklaracija sukladnosti

Mi, Grundfos, izjavljujemo s punom odgovornošću da su proizvodi MTR, SPK, MTH, MTC, MTS, na koja se izjava odnosi u nastavku, u skladu s dolje navedenim direktivama Vijeća o usklađivanju zakona država članica EC/EU-a.

IT: Dichiarazione di conformità CE/UE

Grundfos dichiara sotto la sua esclusiva responsabilità che i prodotti MTR, SPK, MTH, MTC, MTS, ai quale si riferisce questa dichiarazione, sono conformi alle seguenti direttive del Consiglio riguardanti il riavvicinamento delle legislazioni degli Stati membri CE/UE.

BG: Декларация за съответствие на ЕС/ЕО

Ние, фирма Grundfos, заявяваме с пълна отговорност, че продуктите MTR, SPK, MTH, MTC, MTS, за които се отнася настоящата декларация, отговарят на следните директиви на Съвета за уеднаквяване на правните разпоредби на държавите-членки на ЕС/ЕО.

DE: EG-/EU-Konformitätserklärung

Wir, Grundfos, erklären in alleiniger Verantwortung, dass die Produkte MTR, SPK, MTH, MTC, MTS, auf die sich diese Erklärung bezieht, mit den folgenden Richtlinien des Rates zur Angleichung der Rechtsvorschriften der EG-/EU-Mitgliedsstaaten übereinstimmen.

EE: EÜ/ELi vastavusdeklaratsioon

Meie, Grundfos, kinnitame ja kanname ainuisikulist vastutust selle eest, et toode MTR, SPK, MTH, MTC, MTS, mille kohta all olev deklaratsioon käib, on kooskõlas Nõukogu Direktiividega, mis on nimetatud all pool vastavalt vastuvõetud õigusaktidele ühtlustamise kohta EÜ/EL liikmesriikides.

FI: EY-/EU-vaatimusten mukaisuusvakuutus

Grundfos vakuuttaa omalla vastuullaan, että tuotteet MTR, SPK, MTH, MTC, MTS, joita tämä vakuutus koskee, ovat EY-/EU:n jäsenvaltioiden lainsäädännön lähentämiseen tähtäävien Euroopan neuvoston direktiivien vaatimusten mukaisia seuraavasti.

GR: Δήλωση συμμόρφωσης ΕΚ/ΕΕ

Εμείς, η Grundfos, δηλώνουμε με αποκλειστικά δική μας ευθύνη ότι τα προϊόντα MTR, SPK, MTH, MTC, MTS, στα οποία αναφέρεται η παρακάτω δήλωση, συμμορφώνονται με τις παρακάτω Οδηγίες του Συμβουλίου περί προσέγγισης των νομοθεσιών των κρατών μελών της ΕΚ/ΕΕ.

HU: EC/EU megfeleléségi nyilatkozat

Mi, a Grundfos vállalat, teljes felelősséggel kijelentjük, hogy a(z) MTR, SPK, MTH, MTC, MTS termékek, amelyre az alábbi nyilatkozat vonatkozik, megfelelnek az Európai Unió tagállamainak jogi irányelveit összehangoló tanács alábbi előírásainak.

LT: EB/ES atitikties deklaracija

Mes, Grundfos, su visa atsakomybe pareiškiamo, kad produktai MTR, SPK, MTH, MTC, MTS, kuriems skirta ši deklaracija, atitinka žemiau nurodytas Tarybos Direktyvas dėl EB/ES šalių narių įstatymų suderinimo.

LV: EK/ES atbilstības deklarācija

Sabiedrība Grundfos ar pilnu atbildību paziņo, ka produkti MTR, SPK, MTH, MTC, MTS, uz kuru attiecas tālāk redzamā deklarācija, atbilst tālāk norādītajām Padomes direktīvām par EK/ES dalībvalstu normatīvo aktu tuvināšanu.

PL: Deklaracja zgodności WE/UE

My, Grundfos, oświadczamy z pełną odpowiedzialnością, że nasze produkty MTR, SPK, MTH, MTC, MTS, których deklaracja niniejsza dotyczy, są zgodne z następującymi dyrektywami Rady w sprawie zbliżenia przepisów prawnych państw członkowskich.

RO: Declarația de conformitate CE/UE

Noi Grundfos declarăm pe propria răspundere că produsele MTR, SPK, MTH, MTC, MTS, la care se referă această declarație, sunt în conformitate cu Directivele de Consiliu specificate mai jos privind armonizarea legilor statelor membre CE/UE.

RU: Декларация о соответствии нормам ЕЭС/ЕС

Мы, компания Grundfos, со всей ответственностью заявляем, что изделия MTR, SPK, MTH, MTC, MTS, к которым относится нижеприведённая декларация, соответствуют нижеприведённым Директивам Совета Евросоюза о тождественности законов стран-членов ЕЭС/ЕС.

SI: Izjava o skladnosti ES/EU

V Grundfosu s polno odgovornostjo izjavljamo, da je izdelek MTR, SPK, MTH, MTC, MTS, na katerega se spodnja izjava nanaša, v skladu s spodnjimi direktivami Sveta o približevanju zakonodaje za izenačevanje pravnih predpisov držav članic ES/EU.

TR: EC/AB uygunluk bildiřgesi

Grundfos olarak, aşağıdaki bildirim konusu olan MTR, SPK, MTH, MTC, MTS ürünlerinin, EC/AB Üye ülkelerinin direktiflerinin yakınlaştırmasıyla ilgili durumun aşağıdaki Konsey Direktifleriyle uyumlu olduğunu ve bununla ilgili olarak tüm sorumluluğun bize ait olduğunu beyan ederiz.

CN: 欧盟符合性声明

我们，格兰富，在我们的全权责任下声明，产品 MTR, SPK, MTH, MTC, MTS 系列，其制造和性能完全符合以下所列欧盟委员会指令。

NL: EG-/EU-conformiteitsverklaring

Wij, Grundfos, verklaren geheel onder eigen verantwoordelijkheid dat de producten MTR, SPK, MTH, MTC, MTS, waarop de onderstaande verklaring betrekking heeft, in overeenstemming zijn met de onderstaande Richtlijnen van de Raad inzake de onderlinge aanpassing van de wetgeving van de EG-/EU-lidstaten.

PT: Declaração de conformidade CE/UE

A Grundfos declara sob sua única responsabilidade que os produtos MTR, SPK, MTH, MTC, MTS, aos quais diz respeito a declaração abaixo, estão em conformidade com as Diretivas do Conselho sobre a aproximação das legislações dos Estados Membros da CE/UE.

RS: Deklaracija o usklađenosti EC/EU

Mi, kompanija Grundfos, izjavljujemo pod punom vlastitom odgovornošću da je proizvod MTR, SPK, MTH, MTC, MTS, na koji se odnosi deklaracija ispod, u skladu sa dole prikazanim direktivama Saveta za usklađivanje zakona država članica EC/EU.

SE: EG-/EU-försäkran om överensstämmelse

Vi, Grundfos, försäkrar under ansvar att produkterna MTR, SPK, MTH, MTC, MTS, som omfattas av nedanstående försäkran, är i överensstämmelse med de rådsdirektiv om inbördes närmande till EG-/EU-medlemsstaternas lagstiftning som listas nedan.

SK: EC/EU vyhlásenie o zhode

My, spoločnosť Grundfos, vyhlasujeme na svoju plnú zodpovednosť, že produkty MTR, SPK, MTH, MTC, MTS na ktoré sa vyhlásenie uvedené nižšie vzťahuje, sú v súlade s ustanoveniami nižšie uvedených smerníc Rady pre zblíženie právnych predpisov členských štátov EC/EÚ.

UA: Декларація відповідності директивам EC/UE

Ми, компанія Grundfos, під нашу одноосібну відповідальність заявляємо, що вироби MTR, SPK, MTH, MTC, MTS, до яких відносяться нижченаведена декларація, відповідають директивам EC/UE, переліченим нижче, щодо тотожності законів країн-членів ЄС.

JP: EC/EU 適合宣言

Grundfos は、その責任の下に、MTR, SPK, MTH, MTC, MTS 製品が EU 加盟諸国の法規に関連する、以下の評議会指令に適合していることを宣言します。

KO: EC/EU 적합성 선언

Grundfos는 아래의 선언과 관련된 MTR, SPK, MTH, MTC, MTS 제품이 EU 회원국 법률에 기반하여 아래의 이사회 지침을 준수함을 단독 책임 하에 선언합니다.

ID: Deklarasi kesesuaian Komunitas Eropa/Uni Eropa

Kami, Grundfos, menyatakan dengan tanggung jawab kami sendiri bahwa produk MTR, SPK, MTH, MTC, MTS, yang berkaitan dengan pernyataan ini, sesuai dengan Petunjuk Dewan berikut ini serta sedapat mungkin sesuai dengan hukum negara-negara anggota Komunitas Eropa/Uni Eropa.

MK: Декларација за сообразност на ЕЗ/ЕУ

Ние, Grundfos, изјавуваме под целосна одговорност дека производителите MTR, SPK, MTH, MTC, MTS, на кои се однесува долунаведената декларација, се во согласност со овие директиви на Советот за приближување на законите на земјите-членки на ЕЗ/ЕУ.

NO: EFs/EUs samsvarsærklæring

Vi, Grundfos, erklærer under vårt eneansvar at produktene MTR, SPK, MTH, MTC, MTS som denne erklæringen gjelder, er i samsvar med styrets direktiver om tilnærming av forordninger i EF-/EU-landene.

TH: คำประกาศความสอดคล้องตามมาตรฐาน EC/EU

เราในนามของบริษัท Grundfos ขอประกาศภายใต้ความรับผิดชอบของเราแต่เพียงผู้เดียวว่าผลิตภัณฑ์ MTR, SPK, MTH, MTC, MTS ซึ่งเกี่ยวข้องกับคำประกาศนี้ มีความสอดคล้องกับระเบียบคำสั่งตามรายการด้านล่างนี้ของสภาวิชาชีพว่าด้วยค่าประมาณตามกฎหมายของรัฐที่เป็นสมาชิก EC/EU

VI: TUYÊN BỐ TUÂN THỦ EC/EU

Chúng tôi, Grundfos, tuyên bố trong phạm vi trách nhiệm duy nhất của mình rằng sản phẩm MTR, SPK, MTH, MTC, MTS mà tuyên bố dưới đây có liên quan tuân thủ các Chỉ thị Hội đồng sau về việc áp dụng luật pháp của các nước thành viên EC/EU.

IS: EB/ESB-samræmisýfirlýsing

Við, Grundfos, lýsum því yfir og ábyrgjumst að fullu að vörum MTR, SPK, MTH, MTC, MTS, sem þessi yfirlýsing á við um, samræmist tilskipunum ráðs Evrópubandalaganna um samræmingu laga aðildarríkja EB/ESB.

BS: Izjava o usklađenosti EC/EU

Mi, kompanija Grundfos, izjavljujemo pod vlastitom odgovornošću da je proizvod MTR, SPK, MTH, MTC, MTS, na koji se odnosi izjava ispod, u skladu sa niže prikazanim direktivama Vijeća o usklađivanju zakona država članica EC/EU.

KZ: Сәйкестік жөніндегі ЕК/ЕО декларациясы

Біз, Grundfos, ЕК/ЕО мүше елдерінің заңдарына жақын төменде көрсетілген Кеңес директиваларына сәйкес төмендегі декларацияға қатысты MTR, SPK, MTH, MTC, MTS өнімдері біздің жеке жауапкершілігімізде екенін мәлімдейміз.

MY: Perisytiharan keakuran EC/EU

Kami, Grundfos, mengisytiharkan di bawah tanggungjawab kami semata-mata bahawa produk MTR, SPK, MTH, MTC, MTS, yang berkaitan dengan perisytiharan di bawah, akur dengan Perintah Majlis yang disenaraikan di bawah ini tentang penghampiran undang-undang negara ahli EC/EU.

(EC/EU) إقرار مطابقة الاتحاد الأوروبي :AR

نقر نحن، جرونڤوس، بمقتضى مسؤوليتنا الفردية بأن المنتجين MTR, SPK, MTH, MTC, MTS، اللذين يختص بهما الإقرار أدناه، يكونان مطابقين لتوجيهات المجلس المذكورة أدناه بشأن التقريب بين قوانين الدول أعضاء الاتحاد الأوروبي (EC/EU).

TW: EC/EU 合格聲明

葛蘭富根據我們唯一的責任，茲聲明與以下聲明相關之 MTR, SPK, MTH, MTC, MTS 產品，符合下列近似 EU 會員國法律之議會指令。

AL: Deklara e konformitetit të KE/BE

Ne, Grundfos, deklarojmë vetëm nën përgjegjësinë tonë se produktet MTR, SPK, MTH, MTC, MTS, me të cilat lidhet kjo deklaratë, janë në pajtueshmëri me direktivat e Këshillit të renditura më poshtë për për afrimin e ligjeve të shteteve anëtare të KE-/BE-së.

- Machinery Directive (2006/42/EC).
Standards used:
EN 809:1998, A1:2009.
- EcoDesign Directive 2009/125/EC
- RoHS Directives: (2011/65/EU and 2015/863/EU).
Standard used:
EN IEC 63000:2018.

This EC/EU declaration of conformity is only valid when published as part of the Grundfos installation and operating instructions or safety instructions (publication number 98476088, 96440790, 96496967, 98189180).

Bjerringbro, January 1, 2022



Jimm Feldborg
Head of PD IND
Grundfos Holding A/S
Poul Due Jensens Vej 7
8850 Bjerringbro, Denmark

Person authorised to compile technical file and empowered to sign the EC/EU declaration of conformity.

Declaration of conformity

UK declaration of conformity

We, Grundfos, declare under our sole responsibility that the products to which the declaration below relates, are in conformity with UK regulations, standards and specifications to which conformity is declared, as listed below:

Valid for Grundfos products:

MTR, SPK, MTH, MTC, MTS

- Supply of Machinery (Safety) Regulations 2008
Standards used: EN 809:1998, A1:2009.
- The Ecodesign for Energy-Related Products and Energy Information Regulations 2021 and 2019
- The Restriction of the Use of Certain Hazardous Substances in Electrical and Electronic Equipment Regulations 2019
Standards used: EN IEC 63000:2018.

This UK declaration of conformity is only valid when accompanying Grundfos instructions.

UK Importer: Grundfos Pumps Ltd. Grovebury Road, Leighton Buzzard, LU7 4TL.

Bjerringbro, January 1, 2022



Jimm Feldborg
Head of PD IND
Grundfos Holding A/S
Poul Due Jensens Vej 7
8850 Bjerringbro, Denmark

Manufacturer, person authorised to compile the technical file and person empowered to sign the UK declaration of conformity.

10000418662

Argentina

Bombas GRUNDFOS de Argentina S.A.
Ruta Panamericana km. 37.500/Industin
1610 - Garin Pcia. de B.A.
Tel.: +54-3327 414 444
Fax: +54-3327 45 3190

Australia

GRUNDFOS Pumps Pty. Ltd.
P.O. Box 2040
Regency Park
South Australia 5942
Tel.: +61-8-8461-4611
Fax: +61-8-8340-0155

Austria

GRUNDFOS Pumpen Vertrieb
Ges.m.b.H.
Grundfosstraße 2
A-5082 Grödig/Salzburg
Tel.: +43-6246-883-0
Fax: +43-6246-883-30

Belgium

N.V. GRUNDFOS Bellux S.A.
Boomssesteenweg 81-83
B-2630 Aartselaar
Tel.: +32-3-870 7300
Fax: +32-3-870 7301

Belarus

Представительство ГРУНДФОС в
Минске
220125, Минск
ул. Шафарнянская, 11, оф. 56, БЦ
«Порт»
Тел.: +375 17 397 397 3
+375 17 397 397 4
Факс: +375 17 397 397 1
E-mail: minsk@grundfos.com

Bosnia and Herzegovina

GRUNDFOS Sarajevo
Zmaja od Bosne 7-7A
BiH-71000 Sarajevo
Tel.: +387 33 592 480
Fax: +387 33 590 465
www.ba.grundfos.com
E-mail: grundfos@bih.net.ba

Brazil

BOMBAS GRUNDFOS DO BRASIL
Av. Humberto de Alencar Castelo
Branco, 630
CEP 09850 - 300
São Bernardo do Campo - SP
Tel.: +55-11 4393 5533
Fax: +55-11 4343 5015

Bulgaria

Grundfos Bulgaria EOOD
Slatina District
Iztocna Tangenta street no. 100
BG - 1592 Sofia
Tel.: +359 2 49 22 200
Fax: +359 2 49 22 201
E-mail: bulgaria@grundfos.bg

Canada

GRUNDFOS Canada inc.
2941 Brighton Road
Oakville, Ontario
L6H 6C9
Tel.: +1-905 829 9533
Fax: +1-905 829 9512

China

GRUNDFOS Pumps (Shanghai) Co. Ltd.
10F The Hub, No. 33 Suhong Road
Minhang District
Shanghai 201106 PRC
Tel.: +86 21 612 252 22
Fax: +86 21 612 253 33

Columbia

GRUNDFOS Colombia S.A.S.
Km 1.5 via Siberia-Cota Conj. Potrero
Chico,
Parque Empresarial Arcos de Cota Bod.
1A.
Cota, Cundinamarca
Tel.: +57(1)-2913444
Fax: +57(1)-8764586

Croatia

GRUNDFOS CROATIA d.o.o.
Buzinski prilaz 38, Buzin
HR-10010 Zagreb
Tel.: +385 1 6595 400
Fax: +385 1 6595 499
www.hr.grundfos.com

Czech Republic

GRUNDFOS Sales Czechia and Slovakia
s.r.o.
Čajkovského 21
779 00 Olomouc
Tel.: +420-585-716 111

Denmark

GRUNDFOS DK A/S
Martin Bachs Vej 3
DK-8850 Bjerringbro
Tel.: +45-87 50 50 50
Fax: +45-87 50 51 51
E-mail: info_GDK@grundfos.com
www.grundfos.com/DK

Estonia

GRUNDFOS Pumps Eesti OÜ
Peterburi tee 92G
11415 Tallinn
Tel.: + 372 606 1690
Fax: + 372 606 1691

Finland

OY GRUNDFOS Pumput AB
Trukkikuja 1
FI-01360 Vantaa
Tel.: +358-(0) 207 889 500

France

Pompes GRUNDFOS Distribution S.A.
Parc d'Activités de Chesnes
57, rue de Malacombe
F-38290 St. Quentin Fallavier (Lyon)
Tel.: +33-4 74 82 15 15
Fax: +33-4 74 94 10 51

Germany

GRUNDFOS GMBH
Schlüterstr. 33
40699 Erkrath
Tel.: +49-(0) 211 929 69-0
Fax: +49-(0) 211 929 69-3799
E-mail: infoservice@grundfos.de
Service in Deutschland:
kundendienst@grundfos.de

Greece

GRUNDFOS Hellas A.E.B.E.
20th km. Athinon-Markopoulou Av.
P.O. Box 71
GR-19002 Peania
Tel.: +0030-210-66 83 400
Fax: +0030-210-66 46 273

Hong Kong

GRUNDFOS Pumps (Hong Kong) Ltd.
Unit 1, Ground floor, Siu Wai industrial
Centre
29-33 Wing Hong Street & 68 King Lam
Street, Cheung Sha Wan
Kowloon
Tel.: +852-27861706 / 27861741
Fax: +852-27858664

Hungary

GRUNDFOS Hungária Kft.
Tópark u. 8
H-2045 Törökbalint
Tel.: +36-23 511 110
Fax: +36-23 511 111

India

GRUNDFOS Pumps india Private Limited
118 Old Mahabalipuram Road
Thoraiakkam
Chennai 600 097
Tel.: +91-44 2496 6800

Indonesia

PT GRUNDFOS Pompa
Graha intirub Lt. 2 & 3
Jln. Cililitan Besar No.454, Makasar,
Jakarta Timur
ID-Jakarta 13650
Tel.: +62 21-469-51900
Fax: +62 21-460 6910 / 460 6901

Ireland

GRUNDFOS (Ireland) Ltd.
Unit A, Merrywell Business Park
Ballymount Road Lower
Dublin 12
Tel.: +353-1-4089 800
Fax: +353-1-4089 830

Italy

GRUNDFOS Pompe Italia S.r.l.
Via Gran Sasso 4
I-20060 Truccazzano (Milano)
Tel.: +39-02-95838112
Fax: +39-02-95309290 / 95838461

Japan

GRUNDFOS Pumps K.K.
1-2-3, Shin-Miyakoda, Kita-ku
Hamamatsu
431-2103 Japan
Tel.: +81 53 428 4760
Fax: +81 53 428 5005

Korea

GRUNDFOS Pumps Korea Ltd.
6th Floor, Aju Building 679-5
Yeoksam-dong, Kangnam-ku, 135-916
Seoul, Korea
Tel.: +82-2-5317 600
Fax: +82-2-5633 725

Latvia

SIA GRUNDFOS Pumps Latvia
 Deglava biznesa centrs
 Augusta Deglava ielā 60
 LV-1035, Rīga,
 Tel.: + 371 714 9640, 7 149 641
 Fax: + 371 914 9646

Lithuania

GRUNDFOS Pumps UAB
 Smolensko g. 6
 LT-03201 Vilnius
 Tel.: + 370 52 395 430
 Fax: + 370 52 395 431

Malaysia

GRUNDFOS Pumps Sdn. Bhd.
 7 Jalan Peguam U1/25
 Glenmarie Industrial Park
 40150 Shah Alam, Selangor
 Tel.: +60-3-5569 2922
 Fax: +60-3-5569 2866

Mexico

Bombas GRUNDFOS de México
 S.A. de C.V.
 Boulevard TLC No. 15
 Parque industrial Stiva Aeropuerto
 Apodaca, N.L. 66600
 Tel.: +52-81-8144 4000
 Fax: +52-81-8144 4010

Netherlands

GRUNDFOS Netherlands
 Veluwezoom 35
 1326 AE Almere
 Postbus 22015
 1302 CA ALMERE
 Tel.: +31-88-478 6336
 Fax: +31-88-478 6332
 E-mail: info_gnl@grundfos.com

New Zealand

GRUNDFOS Pumps NZ Ltd.
 17 Beatrice Tinsley Crescent
 North Harbour Industrial Estate
 Albany, Auckland
 Tel.: +64-9-415 3240
 Fax: +64-9-415 3250

Norway

GRUNDFOS Pumper A/S
 Strømsveien 344
 Postboks 235, Leirdal
 N-1011 Oslo
 Tel.: +47-22 90 47 00
 Fax: +47-22 32 21 50

Poland

GRUNDFOS Pompy Sp. z o.o.
 ul. Klonowa 23
 Baranowo k. Poznania
 PL-62-081 Przeźmierowo
 Tel.: (+48-61) 650 13 00
 Fax: (+48-61) 650 13 50

Portugal

Bombas GRUNDFOS Portugal, S.A.
 Rua Calvet de Magalhães, 241
 Apartado 1079
 P-2770-153 Paço de Arcos
 Tel.: +351-21-440 76 00
 Fax: +351-21-440 76 90

Romania

GRUNDFOS Pompe România SRL
 S-PARK BUSINESS CENTER, Clădirea
 A2, etaj 2
 Str. Tipografilor, Nr. 11-15, Sector 1, Cod
 013714
 Bucuresti, Romania
 Tel.: 004 021 2004 100
 E-mail: romania@grundfos.ro

Russia

ООО Грундфос Россия
 ул. Школьная, 39-41
 Москва, RU-109544, Russia
 Тел. (+7) 495 564-88-00 (495) 737-30-00
 Факс (+7) 495 564 8811
 E-mail grundfos.moscow@grundfos.com

Serbia

Grundfos Srbija d.o.o.
 Omladinskih brigada 90b
 11070 Novi Beograd
 Tel.: +381 11 2258 740
 Fax: +381 11 2281 769
 www.rs.grundfos.com

Singapore

GRUNDFOS (Singapore) Pte. Ltd.
 25 Jalan Tukang
 Singapore 619264
 Tel.: +65-6681 9688
 Fax: +65-6681 9689

Slovakia

GRUNDFOS s.r.o.
 Prievozská 4D 821 09 BRATISLAVA
 Tel.: +421 2 5020 1426
 sk.grundfos.com

Slovenia

GRUNDFOS LJUBLJANA, d.o.o.
 Leskoškova 9e, 1122 Ljubljana
 Tel.: +386 (0) 1 568 06 10
 Fax: +386 (0)1 568 06 19
 E-mail: tehnika-si@grundfos.com

South Africa

GRUNDFOS (PTY) LTD
 16 Lascelles Drive, Meadowbrook Estate
 1609 Germiston, Johannesburg
 Tel.: (+27) 10 248 6000
 Fax: (+27) 10 248 6002
 E-mail: lgradidge@grundfos.com

Spain

Bombas GRUNDFOS España S.A.
 Camino de la Fuentequilla, s/n
 E-28110 Algete (Madrid)
 Tel.: +34-91-848 8800
 Fax: +34-91-628 0465

Sweden

GRUNDFOS AB
 Box 333 (Lunnagårdsgatan 6)
 431 24 Mölndal
 Tel.: +46 31 332 23 000
 Fax: +46 31 331 94 60

Switzerland

GRUNDFOS Pumpen AG
 Bruggacherstrasse 10
 CH-8117 Fällanden/ZH
 Tel.: +41-44-806 8111
 Fax: +41-44-806 8115

Taiwan

GRUNDFOS Pumps (Taiwan) Ltd.
 7 Floor, 219 Min-Chuan Road
 Taichung, Taiwan, R.O.C.
 Tel.: +886-4-2305 0868
 Fax: +886-4-2305 0878

Thailand

GRUNDFOS (Thailand) Ltd.
 92 Chaloeem Phrakiat Rama 9 Road
 Dokmai, Pravej, Bangkok 10250
 Tel.: +66-2-725 8999
 Fax: +66-2-725 8998

Turkey

GRUNDFOS POMPA San. ve Tic. Ltd.
 Sti.
 Gebze Organize Sanayi Bölgesi
 Ihsan dede Caddesi
 2. yol 200. Sokak No, 204
 41490 Gebze/ Kocaeli
 Tel.: +90 - 262-679 7979
 Fax: +90 - 262-679 7905
 E-mail: satis@grundfos.com

Ukraine

ТОВ "ГРУНДФОС УКРАЇНА"
 Бізнес Центр Європа
 Столицне шосе, 103
 м. Київ, 03131, Україна
 Tel.: (+38 044) 237 04 00
 Fax: (+38 044) 237 04 01
 E-mail: ukraine@grundfos.com

United Arab Emirates

GRUNDFOS Gulf Distribution
 P.O. Box 16768
 Jebel Ali Free Zone, Dubai
 Tel.: +971 4 8815 166
 Fax: +971 4 8815 136

United Kingdom

GRUNDFOS Pumps Ltd.
 Grovebury Road
 Leighton Buzzard/Beds. LU7 4TL
 Tel.: +44-1525-850000
 Fax: +44-1525-850011

U.S.A.

GRUNDFOS Water Utility Headquarters
 856 Koomey Road
 Brookshire, Texas 77423 USA

Uzbekistan

Grundfos Tashkent, Uzbekistan
 The Representative Office of Grundfos
 Kazakhstan in Uzbekistan
 38a, Oybek street, Tashkent
 Tel.: (+998) 71 150 3290 / 71 150 3291
 Fax: (+998) 71 150 3292

98476141 03.2022

ECM: 1332099
