

DME, Variant AR and AP (60-940 l/h)

Installation and operating instructions



DME AR and AP
Installation and operating instructions
Other languages
<http://net.grundfos.com/qr/i/99301274>

DME, Variant AR and AP (60-940 I/h)

English (GB)	
Installation and operating instructions	5
Čeština (CZ)	
Montážní a provozní návod	41
Deutsch (DE)	
Montage- und Betriebsanleitung	76
Dansk (DK)	
Monterings- og driftsinstruktion	114
Eesti (EE)	
Paigaldus- ja kasutusjuhend	150
Español (ES)	
Instrucciones de instalación y funcionamiento	185
Suomi (FI)	
Asennus- ja käyttöohjeet	223
Français (FR)	
Notice d'installation et de fonctionnement	259
Ελληνικά (GR)	
Οδηγίες εγκατάστασης και λειτουργίας	294
Hrvatski (HR)	
Montažne i pogonske upute	332
Magyar (HU)	
Telepítési és üzemeltetési utasítás	367
Italiano (IT)	
Istruzioni di installazione e funzionamento	404
Lietuviškai (LT)	
Įrengimo ir naudojimo instrukcija	441
Latviešu (LV)	
Uzstādīšanas un ekspluatācijas instrukcija	476
Nederlands (NL)	
Installatie- en bedieningsinstructies	511
Polski (PL)	
Instrukcja montażu i eksploatacji	549
Português (PT)	
Instruções de instalação e funcionamento	586

Română (RO)	
Instrucțiuni de instalare și utilizare	623
Srpski (RS)	
Uputstvo za instalaciju i rad	659
Svenska (SE)	
Monterings- och driftsinstruktion	694
Slovensko (SI)	
Navodila za montažo in obratovanje	729
Türkçe (TR)	
Montaj ve kullanım kılavuzu	764
中文 (CN)	
安装和使用说明书	799
日本語 (JP)	
取扱説明書	831
Norsk (NO)	
Installasjons- og driftsinstruksjoner	866
Dimensions.	901

English (GB) Installation and operating instructions

Original installation and operating instructions

Table of contents

1. Safety instructions	5	5.20 Language	27
1.1 Symbols used in this document	5	5.21 Input setup	27
1.2 Qualification and training of personnel	6	5.22 Empty tank (alarm)	28
1.3 Safety instructions for the operator/user	6	5.23 Measuring units	28
1.4 Safety of the system in the event of a failure in the dosing pump	6	5.24 Dosing monitoring.	29
1.5 Dosing chemicals	6	5.25 Control panel lock.	30
1.6 Diaphragm breakage	7	6. Start-up	32
1.7 Operation with loose dosing head screws	7	7. Calibration	34
2. General description	8	7.1 Direct calibration	34
2.1 Applications	8	7.2 Check calibration	35
2.2 Improper operating methods	8	8. Service	36
2.3 Identification.	8	8.1 Regular maintenance	36
3. Technical data	10	8.2 Cleaning	36
3.1 Mechanical data	10	8.3 Perform service	36
3.2 Electrical data	10	8.4 Diaphragm breakage	38
3.3 Input/output data	11	8.5 Operation with loose dosing head screws	38
3.4 Approvals	11	8.6 Repairs	39
3.5 Dimensions	11	9. Fault finding chart	40
4. Installation	12	10. Disposing of the product	40
4.1 Safety instructions	12		
4.2 Installation environment	12		
4.3 Installation of pump	12		
4.4 Installation example.	13		
4.5 Electrical connection	13		
4.6 Connection overview	14		
5. Functions.	17		
5.1 Control panel	17		
5.2 Start/stop of pump	17		
5.3 Priming/venting of pump	17		
5.4 Level control	18		
5.5 Diaphragm leakage sensor	18		
5.6 Alarm output and indicator lights	18		
5.7 Fieldbus communication	20		
5.8 Menu	20		
5.9 Operating modes	20		
5.10 Manual	21		
5.11 Pulse	21		
5.12 Analog.	21		
5.13 Timer	22		
5.14 Batch	24		
5.15 Anti-cavitation	24		
5.16 Capacity limitation	25		
5.17 Counters	25		
5.18 Resetting	26		
5.19 Return	27		

1. Safety instructions



Read this document before you install the product. Installation and operation must comply with local regulations and accepted codes of good practice.

These installation and operating instructions contain general instructions that must be observed during installation, operation and maintenance of the pump. It must therefore be read by the installation engineer and the relevant qualified operator prior to installation and start-up, and must be available at the installation location at all times.

1.1 Symbols used in this document



WARNING

Indicates a hazardous situation which, if not avoided, could result in death or serious personal injury.



CAUTION

Indicates a hazardous situation which, if not avoided, could result in minor or moderate personal injury.



A blue or grey circle with a white graphical symbol indicates that an action must be taken.



A red or grey circle with a diagonal bar, possibly with a black graphical symbol, indicates that an action must not be taken or must be stopped.



If these instructions are not observed, it may result in malfunction or damage to the equipment.



Tips and advice that make the work easier.

1.2 Qualification and training of personnel

The personnel responsible for the installation, operation and service must be appropriately qualified for these tasks.

Areas of responsibility, levels of authority and the supervision of the personnel must be precisely defined by the operator. If necessary, the personnel must be trained appropriately.

Risks of not observing the safety instructions

Non-observance of the safety instructions may have dangerous consequences for the personnel, the environment and the pump and may result in the loss of any claims for damages.

It may lead to the following hazards:

- Personal injury from exposure to electrical, mechanical and chemical influences.
- Damage to the environment and personal injury from leakage of harmful substances.

1.3 Safety instructions for the operator/user

The safety instructions described in these instructions, existing national regulations on health protection, environmental protection and for accident prevention and any internal working, operating and safety regulations of the operator must be observed.

Information attached to the pump must be observed.

Leakages of dangerous substances must be disposed of in a way that is not harmful to the personnel or the environment.

Damage caused by electrical energy must be prevented, see the regulations of the local electricity supply company.

Before starting work on the pump, the pump must be disconnected from the power supply. The system must be pressureless!

Caution

Note

The mains plug is the separator separating the pump from the mains.

Only original accessories and original spare parts should be used. Using other parts can result in exemption from liability for any resulting consequences.

1.4 Safety of the system in the event of a failure in the dosing pump

The dosing pump was designed according to the latest technologies and is carefully manufactured and tested.

If it fails regardless of this, the safety of the overall system must be ensured. Use the relevant monitoring and control functions for this.

WARNING

Chemical hazard

Death or serious personal injury

- Make sure that any chemicals that are released from the pump or any damaged lines do not cause damage to system parts and buildings.
- The installation of leak monitoring solutions and drip trays is recommended.



1.5 Dosing chemicals

Warning

Before switching the supply voltage back on, the dosing lines must be connected in such a way that any chemicals in the dosing head cannot spray out and put people at risk.

The dosing medium is pressurised and can be harmful to health and the environment.



Warning

When working with chemicals, the accident prevention regulations applicable at the installation site should be applied (e.g. wearing protective clothing).

Observe the chemical manufacturer's safety data sheets and safety instructions when handling chemicals!



Warning

The pump must be equipped with a diaphragm leakage detection when used for crystallising media.



Caution

A deaeration hose, which is routed into a container, e.g. a drip tray, must be connected to the deaeration valve.

The dosing medium must be in liquid aggregate state!

Caution

Observe the freezing and boiling points of the dosing medium!

The resistance of the parts that come into contact with the dosing medium, such as the dosing head, valve ball, gaskets and lines, depends on the medium, media temperature and operating pressure.

Caution

Ensure that parts in contact with the dosing medium are resistant to the dosing medium under operating conditions, see data booklet!

Should you have any questions regarding the material resistance and suitability of the pump for specific dosing media, please contact Grundfos.

1.6 Diaphragm breakage

If the diaphragm leaks or is broken, dosing liquid escapes from the drain opening on the dosing head.

Warning

Danger of explosion, if dosing liquid has entered the pump housing!

Operation with damaged diaphragm can lead to dosing liquid entering the pump housing.



In case of diaphragm breakage, immediately separate the pump from the power supply!

Make sure the pump cannot be put back into operation by accident!

Dismantle the dosing head without connecting the pump to the power supply and make sure no dosing liquid has entered the pump housing. Proceed as described in section Dismantling the diaphragm and valves.

To avoid any danger resulting from diaphragm breakage, observe the following:

- Perform regular maintenance.
- Never operate the pump with blocked or soiled drain opening.
 - If the drain opening is blocked or soiled, proceed as described in section Dismantling the diaphragm and valves.
- Never attach a hose to the drain opening. If a hose is attached to the drain opening, it is impossible to recognise escaping dosing liquid.
- Take suitable precautions to prevent harm to health and damage to property from escaping dosing liquid.
- Never operate the pump with damaged or loose dosing head screws.

Related information

[4.3 Installation of pump](#)

[8.1 Regular maintenance](#)

[8.3.2 Dismantling the diaphragm and valves](#)

[8.4 Diaphragm breakage](#)

1.7 Operation with loose dosing head screws

Warning

Danger of explosion, if dosing liquid has entered the pump housing!

Operation with damaged or loose dosing head screws can lead to dosing liquid entering the pump housing.

If the pump was operated with damaged or loose dosing head screws, immediately separate the pump from the power supply!



Make sure the pump cannot be put back into operation by accident!

Dismantle the dosing head without connecting the pump to the power supply and make sure no dosing liquid has entered the pump housing. Proceed as described in section Dismantling the diaphragm and valves.

Related information

[8.3.2 Dismantling the diaphragm and valves](#)

2. General description

The Grundfos DME dosing pump is a self-priming diaphragm pump.

The pump consists of:

- a **cabinet** incorporating the drive unit and electronics,
- a **dosing head** with back plate, diaphragm, valves, connections and vent valve,
- a **control panel** incorporating display and buttons. The control panel is fitted either to the front or to the side of the cabinet.

The motor is controlled in such a way that the dosing gets as even and constant as possible, irrespective of the capacity range in which the pump is operating.

This is carried out as follows:

The speed of the suction stroke is kept constant and the stroke relatively short, irrespective of the capacity. Contrary to conventional pumps, which generate the dosing stroke as a short pulse, the duration of the dosing stroke will be as long as possible. Thus, an even dosing without peak values is ensured. As the pump is always dosing at full stroke length, it ensures the same high accuracy and suction capability, irrespective of the capacity, which is infinitely variable in the ratio of 1:800.

The pump features an LCD display and a user-friendly control panel which gives access to the pump functions.

2.1 Applications

The pump is suitable for liquid, non-abrasive, non-flammable and non-combustible media strictly in accordance with the instructions in these installation and operating instructions.

Areas of application (among others)

- drinking water treatment
- wastewater treatment
- cooling water treatment
- washing systems
- process water treatment
- chemical industry.

2.2 Improper operating methods

The operational safety of the pump is only guaranteed if it is used in accordance with section Applications.



Warning

Other applications or the operation of pumps in ambient and operating conditions, which are not approved, are considered improper and are not permitted. Grundfos cannot be held liable for any damage resulting from incorrect use.



Warning

The pump must be equipped with a diaphragm leakage detection when used for crystallising media.



Warning

The pump is NOT approved for operation in potentially explosive areas!



Warning

A sunscreen is required for outdoor installation!

Related information

[2.1 Applications](#)

2.3 Identification

2.3.1 Type key

The type key is used to identify the precise pump and is not used for configuration purposes.

Type
DME60-10AR-PP/E/C-F-311F
Nominal dosing capacity [l/h]
DME60-10AR-PP/E/C-F-311F
60
150
375
940
Max. pressure [bar]
DME60-10AR-PP/E/C-F-311F
4
10
Control variant
DME60-10AR-PP/E/C-F-311F
AR Standard
AP Standard + Profibus

Dosing head variantDME60-10AR-PP/E/C-F-311F

PP Polypropylene

PV Polyvinylidene fluoride (PVDF)

SS Stainless steel 1.4401

Gasket material

DME60-10AR-PP/E/C-F-311F

E EPDM

V FKM

T PTFE

Valve ball material

DME60-10AR-PP/E/C-F-311F

G Glass (from DN 32)

T PTFE

SS Stainless steel 1.4401

C Ceramic (up to DN 20)

Control panelDME60-10 AR-PP/E/C-F-311F

F Front-fitted

S Side-fitted

Supply voltageDME60-10AR-PP/E/C-F-311F

3 1 x 100-240 V, 50/60 Hz

Valve typeDME60-10AR-PP/E/C-F-311F

1 Standard valves, not spring-loaded

2 Spring-loaded valve

Hydraulic connectionsDME60-10 AR-PP/E/C-F-311F

A1 Threaded Rp 3/4

A2 Threaded Rp 1 1/4

Q Tubing 19/27 mm + 25/34 mm

Mains plugDME60-10AR-PP/E/C-F-311E

F EU (Schuko)

B USA

G UK

I Australia

E Switzerland

J Japan

L Argentina

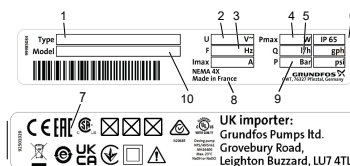
2.3.2 Nameplate

TM080877

Pos. Description

- 1 Type designation
- 2 Voltage
- 3 Frequency
- 4 Power consumption
- 5 Max. dosing flow
- 6 Enclosure class
- 7 Marks of approval
- 8 Country of origin
- 9 Max. operating pressure
- 10 Model

3. Technical data

3.1 Mechanical data

	DME 60	DME 150	DME 375	DME 940
Maximum capacity [l/h] [*]	60	150	376	940
Maximum capacity with anti-cavitation 75 % [l/h] [*]	45	112	282	705
Maximum capacity with anti-cavitation 50 % [l/h] [*]	33.4	83.5	210	525
Maximum capacity with anti-cavitation 25 % [l/h] [*]	16.1	40.4	101	252
Maximum pressure [bar]	10	4	10	4
Maximum stroke rate per minute [strokes/min.]			160	
Maximum suction lift during operation [m]			6	
Maximum suction lift when priming with wet valves [m]			1.5	
Maximum viscosity with spring-loaded valves [mPa s] ^{**}	3000 [mPa s] at 50 % capacity			
Maximum viscosity without spring-loaded valves [mPa s] ^{**}	200			
Diaphragm diameter [mm]	79	106	124	173
Liquid temperature [°C]			0 to 50	
Ambient temperature [°C]			0 to 45	
Accuracy of repeatability			± 1 %	
Sound pressure level [dB(A)]			< 70	

* Irrespective of counter pressure

** Maximum suction lift 1 metre

3.2 Electrical data

	DME 60	DME 150	DME 375	DME 940
Supply voltage [VAC]	1 × 100-240 V			
Maximum current consumption [A]	at 100 V	1.25		2.4
	at 230 V	0.67		1.0
Maximum power consumption P ₁ [W]		67.1		240
Frequency [Hz]			50/60	
Enclosure class			IP65	
Installation category			II	
Pollution degree			2	
Insulation class			B	
Supply cable	1.5 m H05RN-F with plug			

3.3 Input/output data

The pump offers various input and output options, depending on control variant.

Signal input	
Voltage in level sensor input [VDC]	5
Voltage in pulse input [VDC]	5
Minimum pulse-repetition period [ms]	3.3
Impedance in analog 0/4-20 mA input [Ω]	
The analog input requires a signal which is isolated from frame. Min. resistance to frame: 50 k Ω	250
Maximum loop resistance in pulse signal circuit [Ω]	250
Maximum loop resistance in level signal circuit [Ω]	250
Signal output	
Maximum load of alarm relay output, at ohmic load [A]	2
Maximum voltage, alarm relay output [V]	42

3.4 Approvals

Approvals	CE, CSA-US, EAC, NSF61
-----------	---------------------------

NSF61 is only valid for DME 375 and DME 940 standard range (without spring loaded valves).

Certification is based upon a dose rate that yields a sodium hydroxide (NaOH) concentration in potable water that does not exceed 200 mg/L.

Certification is based upon a dose rate that yields a sodium hypochlorite (NaOCl) concentration in potable water that does not exceed 84 mg/L.

Certification of this product has been performed to the health effects requirements of NSF/ANSI Standard 61, which assesses the acceptability of potential extractants from the chemical pump. No evaluation has been performed on the strength or efficacy of the chemical fed. The specified chemicals are not certified by UL to NSF/ANSI Standard 60, so the operation, maintenance and the consistency of the source ingredients may affect the performance of the dosing pump.

3.5 Dimensions

See dimensions at the end of these instructions.



All dimensions are in mm.

4. Installation

4.1 Safety instructions

- Liquid is under pressure and may be hazardous.
- When working with chemicals, local safety rules and regulations must be observed (e.g. wear protective clothes).
- Before starting work on the dosing pump and system, disconnect the electricity supply to the pump, ensuring that it cannot be accidentally switched on. Before reconnecting the electricity supply, make sure that the dosing hose is positioned in such a way that any chemical left in the dosing head is not ejected, thereby exposing persons to danger.
- If the vent valve in the dosing head is used, it must be connected to a hose which is led back to the tank.
- When changing a chemical, make sure that the materials of the dosing pump and system are resistant to the new chemical. If there is any risk of chemical reaction between the two types of chemicals, clean the pump and system thoroughly before adding the new chemical. Proceed as follows: Place the suction tube in water and press the  button until residual chemical has been removed.



When the buttons  and  are pressed simultaneously, the pump can be set to run for a specific number of seconds at maximum capacity. The remaining number of seconds will appear in the display. The maximum value is 300 seconds.

4.2 Installation environment

- Exposure to direct sunlight should be avoided. This applies especially to pumps with plastic dosing heads, as this material can be damaged by sunlight.
- If the pump is installed outside, an enclosure or similar protection is required to protect the pump against rain and similar weathers.

4.3 Installation of pump

- See also section Installation example.

The dosing head may contain water from the factory test. If a liquid which must not come into contact with water is to be dosed, it is recommended to let the pump run with another liquid to remove the water from the dosing head before installation.

Caution

Cross-tighten the dosing head screws with a torque wrench once before commissioning and again after 2-5 operating hours at 5.5 Nm (+0.5 / -0 Nm).

Caution

- Always install the pump on the supporting foot with vertical suction and discharge ports.
- Always use suitable tools for the mounting of plastic parts. Never apply unnecessary force.
- Make sure that the dosing pump and system are designed in such a way that neither system equipment nor buildings are damaged in case of leakage from the pump or rupture of hoses/pipes. The installation of leakage hoses and collecting tanks is recommended.
- Make sure that the drain hole (1) in the dosing head points downwards.

Caution

Never attach a hose to the drain opening.

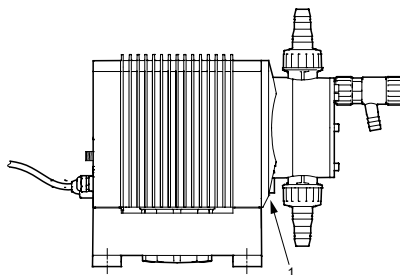

Position of drain hole (1)

TM027066

Related information

[4.4 Installation example](#)

4.4 Installation example

The drawing shows an installation example.

The DME pump can be installed in many different ways. The sketch below shows an example with side-fitted control panel. The tank is a Grundfos chemical tank with a Grundfos level control unit.

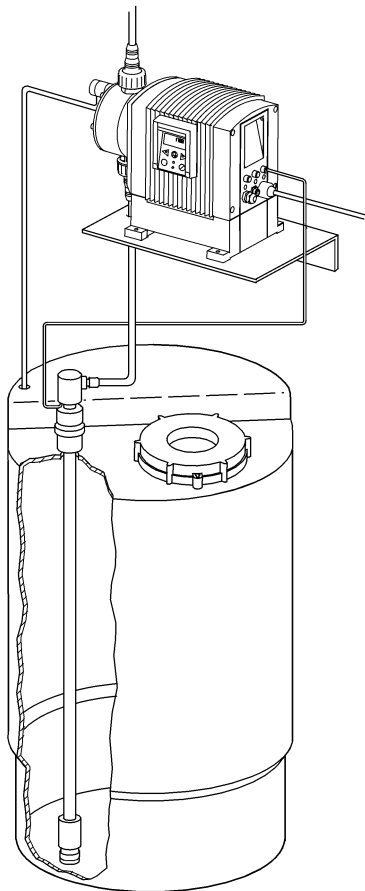

TM027065

4.5 Electrical connection

- The electrical connection of the pump should be carried out by qualified persons in accordance with local regulations.
- For electrical data of the pump, see section Electrical data.
- Do not lay signal cables, if any, together with power cables.

Warning

Danger to life due to non-tripping of the residual current device (RCD)!



If the pump is connected to an electric installation where a residual current device (RCD) is used as an additional protection, this RCD must trip when earth fault currents with DC content (pulsating DC) and smooth DC earth fault currents occur. This means that a RCD type B, sensitive to universal current, must be used.

Related information

[3.2 Electrical data](#)

4.6 Connection overview

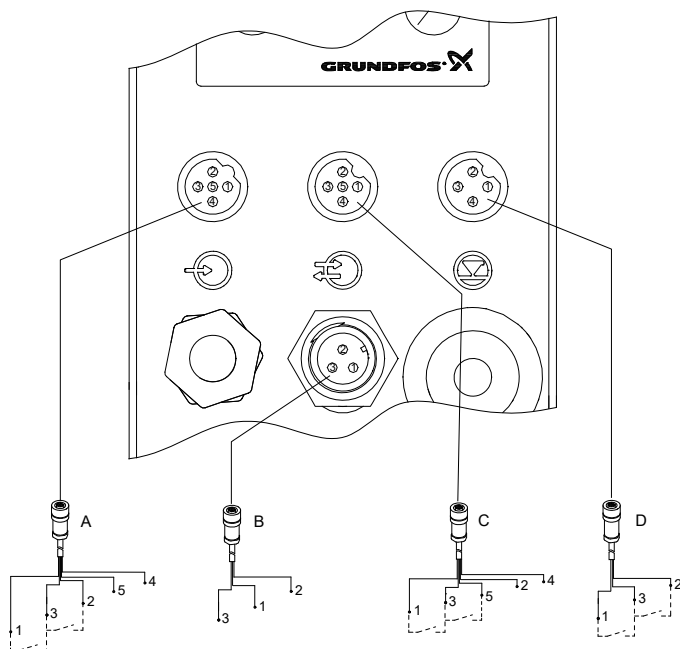

TM027069

Cable A: Input for analog signal, pulse signal and diaphragm leakage

Number / colour	1 / brown	2 / white	3 / blue	4 / black	5 / grey
Function					
Analog				(-) 4-20 mA input	(+) 4-20 mA input
Pulse	Potential-free		Potential-free		
Pulse	5 V			Ground	
Number / colour		2 / black	3 / brown	4 / blue	
Diaphragm leakage ¹⁾		5 V	PNP	Ground	

1) Grundfos diaphragm leakage sensor, product number 96534443.

Cable B: Alarm relay output

Number / colour	1 / brown	2 / white	3 / blue
Function			
Alarm relay	Common	Normally open	Normally closed

Table C: Input for dosing stop and dosing monitoring or dosing output

Number / colour	1 / brown	2 / white	3 / blue	4 / black	5 / grey
Function					
Dosing stop (input)	5 V			Ground	
Dosing stop (input)	Potential-free		Potential-free		
Dosing monitoring			Potential-free		Potential-free
Dosing monitoring				Ground	5 V
Dosing output (pump running)		Open collector (NPN) ²⁾		Ground	

2) Open collector (NPN) can be used for a relay or a lamp.

1. Using the internal 5 VDC power supply:

Max. current: 100 mA

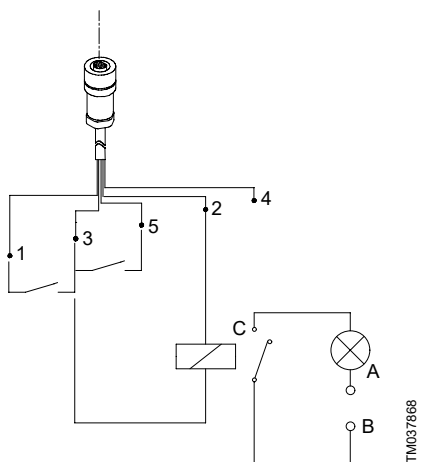

TM037668

2. Using an external power supply:

Max. 24 VDC - 100 mA

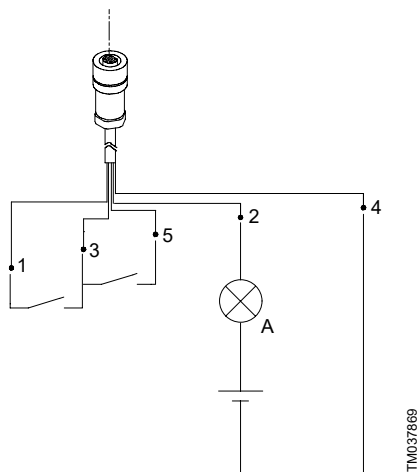

TM037669

Pos.	Description
A	Lamp
B	Power
C	Relay

Cable D: Level input

Number / colour	1 / brown	2 / white	3 / blue	4 / black
Function				
Empty tank	Potential-free ³⁾		Potential-free ³⁾	
Empty tank	5 V			Ground
Low level		Potential-free ³⁾	Potential-free ³⁾	
Low level		5 V		Ground

³⁾ The function of the potential-free contact sets can be selected via the control panel (NO = normally open and NC = normally closed), see section Input setup.

Related information*5.21 Input setup*

5. Functions

5.1 Control panel

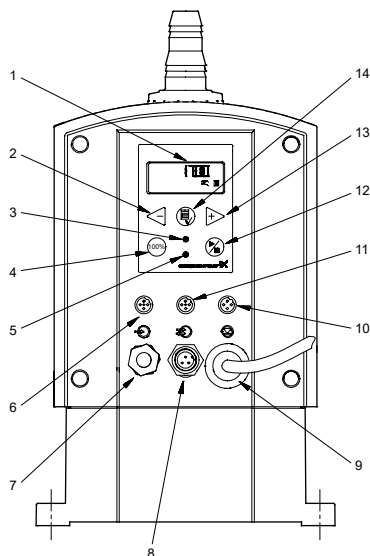

TM027068

Pos.	Description
1	LCD display. See section Menu
2	Navigation/settings. See section Menu
3	Green indicator light. See section Alarm output and indicator lights
4	Maximum capacity (priming). See section Priming/venting of pump
5	Red indicator light. See section Alarm output and indicator lights
6	M12 connection analog/pulse/leakage input. See sections Pulse, Analog, Diaphragm leakage sensor
7	Cable for Profibus control. See section Fieldbus communication
8	Connection alarm relay. See section Alarm output and indicator lights
9	Power supply
10	M12 connection level control. See section Level control

Pos.	Description
11	M12 connection stop dosing. See section Start/stop of pump
12	On/off button. See section Menu
13	Navigation/settings. See section Menu
14	Menu. See section Menu

Related information

- [5.2 Start/stop of pump](#)
- [5.3 Priming/venting of pump](#)
- [5.4 Level control](#)
- [5.5 Diaphragm leakage sensor](#)
- [5.7 Fieldbus communication](#)
- [5.8 Menu](#)
- [5.11 Pulse](#)
- [5.12 Analog](#)

5.2 Start/stop of pump

The pump can be started/stopped in two different ways:



- Locally on the pump control panel.
- By means of an external on/off switch. See section Connection overview.

Related information

- [4.6 Connection overview](#)

5.3 Priming/venting of pump

The pump control panel incorporates a  button. Press this button if the maximum pump capacity is required over a short period, e.g. during start-up. When the button is released, the pump automatically returns to the previous operating mode. During priming/venting, it is recommended to let the pump run without a counter pressure or to open the vent valve.

Note: When the buttons  and  are pressed simultaneously, the pump can be set to run for a specific number of seconds at maximum capacity. The remaining number of seconds will appear in the display. The maximum value is 300 seconds.

5.4 Level control

The pump can be fitted with a level control unit for monitoring of the chemical level in the tank.

The pump can react to two level signals. The pump will react differently, depending on the influence on the individual level sensors.

Level sensors	Pump reaction
Upper sensor activated (closed contact)	Red indicator light is on. Pump running . Alarm relay activated.
Lower sensor activated (closed contact)	Red indicator light is on. Pump stopped . Alarm relay activated.

For connection of the level control unit and alarm output, see section Connection overview.

5.6 Alarm output and indicator lights





The green and red indicator lights on the pump are used for operating and fault indication.

In control variant "AR", the pump can activate an external alarm signal by means of a built-in alarm relay which must only be connected to a safety extra low voltage (SELV) connection.

Note Connect the alarm relay only to voltages which comply with the SELV requirements in EN/IEC 60335-1.

The alarm signal is activated by means of an internal potential-free contact.

The functions of the indicator lights and the built-in alarm relay appear from the table below.

Condition	Green LED	Red LED	Display	Alarm output
Pump running	On	Off	Normal indication	
Set to stop	Flashing	Off	Normal indication	
Pump fault	Off	On	EEPROM	
Supply failure	Off	Off	Off	
Pump running, low chemical level ¹⁾	On	On	LOW	

Related information

[4.6 Connection overview](#)

5.5 Diaphragm leakage sensor

The pump can be fitted with a diaphragm leakage sensor, which detects diaphragm leakage.

The sensor should be connected to the drain hole in the dosing head.











In case of diaphragm leakage, the signal from the sensor generates an alarm and the alarm relay will be activated. See also section Alarm output and indicator lights.

For connection of the diaphragm leakage sensor, see section Connection overview.

Related information

[4.6 Connection overview](#)

[5.6 Alarm output and indicator lights](#)

Condition	Green LED	Red LED	Display	Alarm output
Empty tank ¹⁾	Off	On	EMPTY	
Analog signal < 2 mA	Off	On	NO mA	
The pump is running, but the dosed is too small according to the signal from the dosing monitor ²⁾	On	On	NO FLOW	
Overheating	Off	On	MAX. TEMP.	
Internal communication fault	Off	On	INT. COM.	
Internal Hall fault ³⁾	Off	On	HALL	
Diaphragm leakage ⁴⁾	Off	On	LEAKAGE	
Maximum pressure exceeded ⁴⁾	Off ⁵⁾	On	OVERLOAD	
More pulses than capacity	On	On	MAX. FLOW	
No motor rotation detected ³⁾	Off	On	ORIGO	

1) Requires connection to level sensors. See section Empty tank (alarm).

2) Requires activation of the dosing monitoring function and connection to a dosing monitor.

3) Please contact a Grundfos service centre.

4) Alarms can be reset when the faults have been corrected.

5) The pump will make 10 attempts to restart before going into permanent OFF mode.

Related information

[5.22 Empty tank \(alarm\)](#)

5.7 Fieldbus communication

The pump can be configured for fieldbus applications (Profibus). Apart from the usual installation and operating instructions, Profibus pumps are supplied with a special Profibus installation and operating instructions.

5.8 Menu

The pump features a user-friendly menu which is activated by pressing the  button. During start-up, all texts will appear in English language. To select language, see section Language.

All menu items are described in the following

sections. When  appears at a menu item, it means that this item is activated. By selecting "RETURN" anywhere in the menu structure, you will return to the operating display without changes.

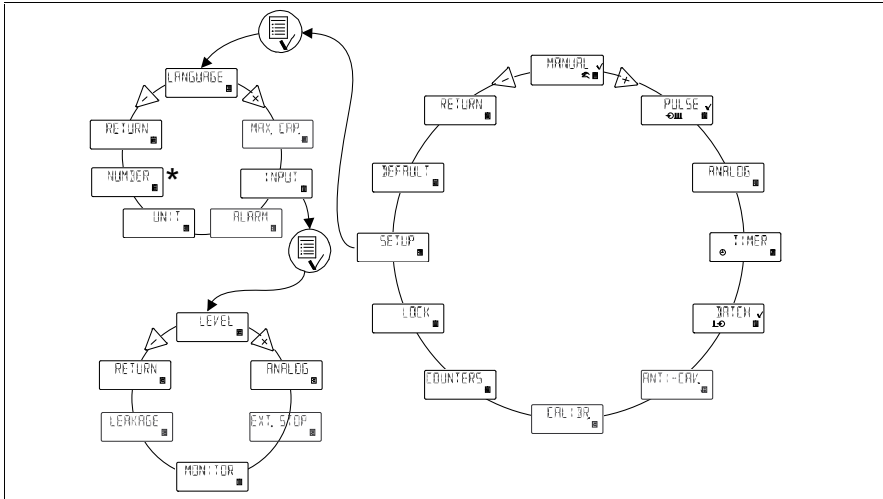

TM077984

* "NUMBER" applies only to versions with Profibus.

Related information

- [5.10 Manual](#)
- [5.11 Pulse](#)
- [5.12 Analog](#)
- [5.13 Timer](#)
- [5.14 Batch](#)
- [5.15 Anti-cavitation](#)
- [5.16 Capacity limitation](#)
- [5.17 Counters](#)
- [5.18 Resetting](#)
- [5.19 Return](#)
- [5.20 Language](#)
- [5.21 Input setup](#)
- [5.22 Empty tank \(alarm\)](#)
- [5.23 Measuring units](#)
- [5.25 Control panel lock](#)
- [7. Calibration](#)

5.9 Operating modes

Note

The displayed I and ml values are only reliable if the pump has been calibrated to the actual installation, see section Calibration

The pump can run in five different operating modes:

- **Manual**
- **Pulse**
- **Analog**
- **Timer** (internal batch control)
- **Batch** (external batch control)

See description in the following sections.

Related information

- [7. Calibration](#)

5.10 Manual

The pump is dosing as constantly and evenly as possible, without any external signals.

Set the quantity to be dosed in l/h or ml/h. The pump automatically changes between the measuring units.

Setting range:

DME 60: 75 ml/h - 60 l/h

DME 150: 200 ml/h - 150 l/h

DME 375: 500 ml/h - 375 l/h

DME 940: 1200 ml/h - 940 l/h

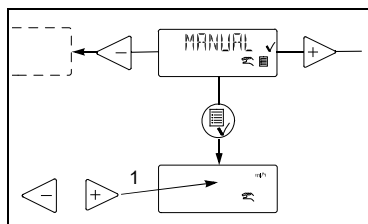

TM077992

Pos.	Description
1	Set value

5.11 Pulse

The pump is dosing according to an external pulse signal, i.e. a water meter with pulse output or a controller.

Set the quantity to be dosed per pulse in ml/pulse. The pump adjusts its capacity according to two factors:

- Frequency of external pulses.
- The set quantity per pulse.

The pump measures the time between two pulses and then calculates the speed giving the capacity required (set quantity per pulse multiplied by the pulse frequency).

The pump does not start until it has received the second pulse, and thus it delivers a constant flow as in the case of "manual" control. The pump calculates a speed for each pulse received.

The pump stops

- when the time between two pulses is three times longer than the time between the two previous pulses, or
- if the time between two pulses exceeds 2 minutes.

The pump will operate at the latest calculated speed until one of the two cases occurs.

The pump stops at the point reached in its duty cycle and starts at this point again having received two new pulses.

Setting range:

DME 60: 0.000625 ml/pulse - 120 ml/pulse

DME 150: 0.00156 ml/pulse - 300 ml/pulse

DME 375: 0.00392 ml/pulse - 750 ml/pulse

DME 940: 0.00980 ml/pulse - 1880 ml/pulse

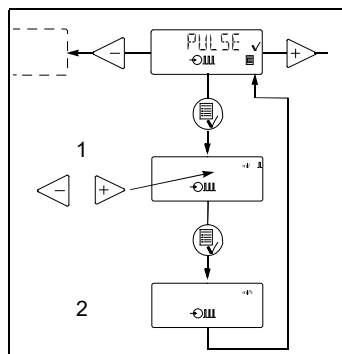

TM077995

Pos.	Description
1	Set quantity in ml/pulse
2	Actual capacity in ml/h or l/h

If the set quantity per pulse multiplied by the pulse frequency exceeds the pump capacity, the pump will run at maximum capacity. Excess pulses will be ignored and "MAX. FLOW" will appear in the display.

5.12 Analog

The pump is dosing according to an external analog signal. The dosed quantity is proportional to the input value in mA.

4-20 (default): 4 mA = 0 %; 20 mA = 100 %

20-4: 4 mA = 100 %; 20 mA = 0 %

0-20: 0 mA = 0 %; 20 mA = 100 %

20-0: 0 mA = 100 %; 20 mA = 0 %

The capacity limitation will influence the capacity. 100 % corresponds to the maximum capacity of the pump or the set maximum capacity, see section Capacity limitation.

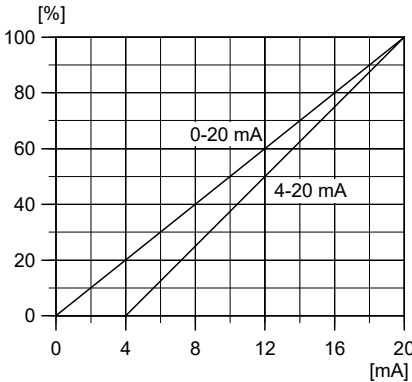

TM024498

The analog input requires a signal which is isolated from frame. Min. resistance to frame: 50 kΩ.

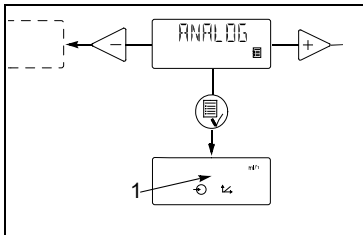

TM077981

Pos.	Description
1	Value according to analog signal

If 4-20 mA or 20-4 mA is selected and the signal falls below 2 mA, the pump will indicate a fault. This situation occurs if the connection is interrupted, for instance if the wire is damaged.

Change the analog mode as illustrated:

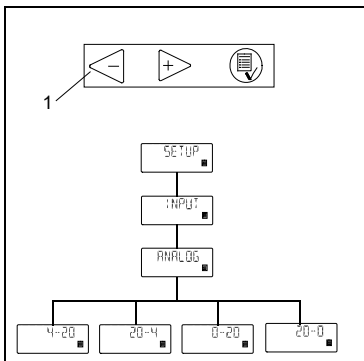

TM078011

Pos.	Description
1	Use the buttons for navigation

Related information

[5.16 Capacity limitation](#)

5.13 Timer

The pump is dosing the set quantity in batches at the maximum capacity or the set maximum capacity, see section Capacity limitation.

The time until the first dosing "NX" and the following sequences "IN" can be set in minutes, hours and days. The maximum time limit is 9 days, 23 hours and 59 minutes (9:23:59). The lowest acceptable value is 1 minute. The internal timer continues even if the pump is stopped by means of the on/off button, empty tank or stop signal.

During operation, "NX" will always count down from "IN" to zero. In this way, the remaining time until the next batch can always be read.

"IN" must be higher than the time required to perform one batch. If "IN" is lower, the next batch will be ignored.

In case of supply failure, the set quantity to be dosed, the "IN" time and the remaining "NX" time are stored. When the supply is reconnected, the pump will start up with the "NX" time at the time of the supply failure. In this way, the timer cycle will continue, but it has been delayed by the duration of the supply failure.

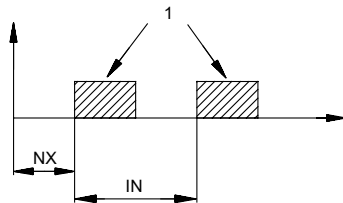

TM018942

Pos.	Description
1	Quantity per batch

Setting range:

- DME 60: 6.25 ml/batch - 120 l/batch
- DME 150: 15.6 ml/batch - 300 l/batch
- DME 375: 39.1 ml/batch - 750 l/batch
- DME 940: 97.9 ml/batch - 1880 l/batch

Only values corresponding to complete dosing strokes (according to the calibration factor) can be selected. The minimum setting depends on the calibration factor. The minimum setting shown above corresponds to the default calibration value.

Example:

If the calibration factor is 625 (= 6.25 ml/stroke), the minimum settable value in timer or batch mode will be 6.25 ml (= 1 stroke) -> the next will be 12.5 ml (= 2 strokes), etc.

These steps will continue up to a value corresponding to 100 dosing strokes. Above this value, the setting range has standard steps as in other operating modes.

If the calibration factor is changed after the setting of timer or batch mode, the pump will automatically recalculate a new number of dosing strokes per batch and change the display value to the nearest possible value compared to the first one set.

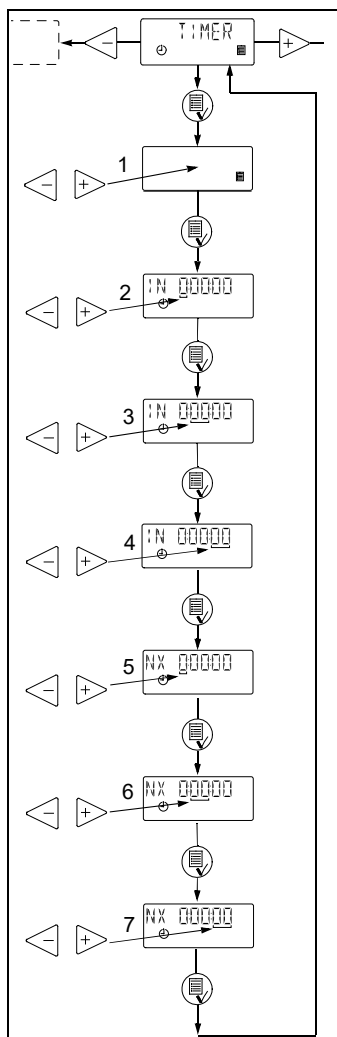

TM077987

Pos.	Description
1	Set quantity per batch
2	Set IN value in days
3	Set IN value in hours
4	Set IN value in minutes
5	Set NX value in days
6	Set NX value in hours
7	Set NX value in minutes

Related information

[5.16 Capacity limitation](#)

5.14 Batch

The pump is dosing the set quantity in batches at the maximum capacity or the set maximum capacity, see section Capacity limitation.

The quantity is dosed every time the pump receives an external pulse.

If the pump receives new pulses before the previous batch is performed, these pulses will be ignored.

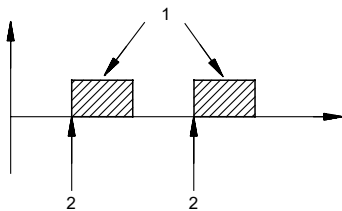

TM018947

Pos.	Description
1	Quantity per batch
2	Pulse

The setting range is the same as for Timer, see section Timer.

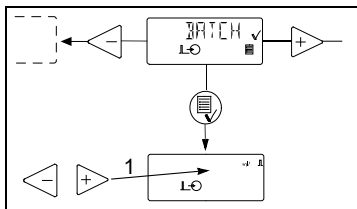

TM007983

Pos.	Description
1	Set value per batch

Related information

[5.13 Timer](#)

[5.16 Capacity limitation](#)

5.15 Anti-cavitation

The pump features an anti-cavitation function. When this function is selected, the pump extends its suction stroke, resulting in optimized priming.

The anti-cavitation function is used:

- when pumping liquids of high viscosity
- in the case of a long suction tube
- in the case of a high suction lift.

Depending on the circumstances, the motor speed during the suction stroke can be reduced by 75 %, 50 % or 25 % compared to the normal motor speed during the suction stroke.

The maximum pump capacity is reduced when the anti-cavitation function is selected. See section Mechanical data.

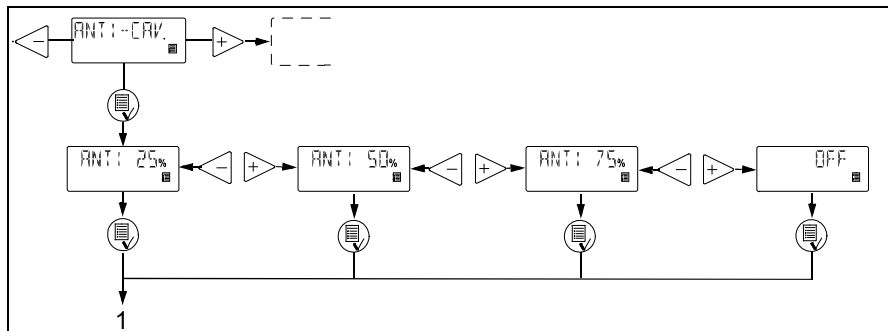

TM077982

Pos.	Description
1	Operating display

Pos.	Description
1	Operating display
2	Set maximum capacity

Related information

3.1 Mechanical data

5.16 Capacity limitation

This function offers the possibility of reducing the maximum pump capacity (MAX. CAP.). It influences the functions in which the pump is normally operating at maximum capacity.

Under normal operating conditions, the pump cannot operate at a capacity which is higher than the one stated in the display. This does not apply to the

maximum capacity button , see section Priming/venting of pump.

Related information

5.3 Priming/venting of pump

5.17 Counters

The pump can display "non-resettable" counters for:

- "QUANTITY" Accumulated value of dosed quantity in litres or US gallons.
- "STROKES" Accumulated number of dosing strokes.
- "HOURS" Accumulated number of operating hours.
- "POWER ON" Accumulated number of times the electricity supply has been switched on.

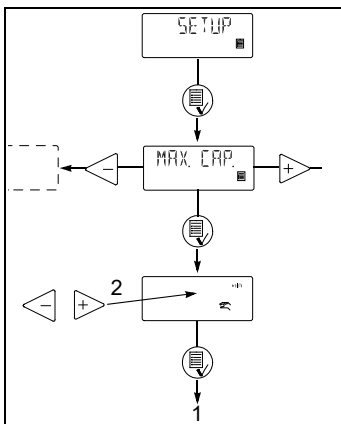

TM077985

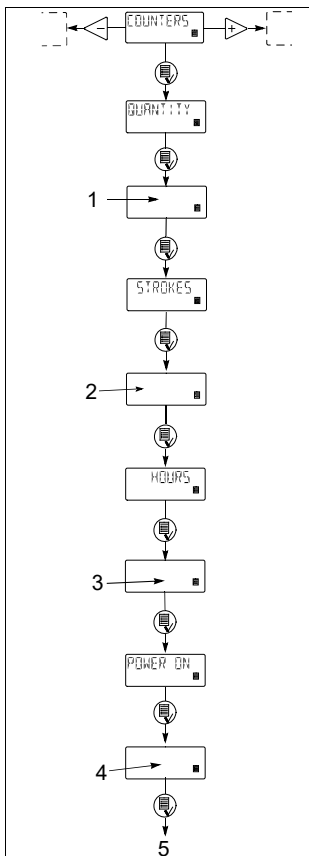

TM077987

Pos.	Description
1	Total dosed quantity
2	Total number of strokes
3	Total number of operating hours
4	Total number of starts
5	Operating display

5.18 Resetting

When "DEFAULT" is activated, the pump will return to the factory settings.

Note: The calibration is also set back to the default setting. This means that a new calibration is required when the "DEFAULT" function has been used.

Default settings are the factory settings of standard pumps. Select "DEFAULT" in the "SETUP" menu.

Default settings:

- Operating mode:** Manual
- Capacity: Maximum capacity
- Control panel lock: Unlocked
- Default lock code: 2583
- Anti-cavitation: Not active
- Analogue signal: 4-20 mA
- Digital inputs: NO (normally open)
- Capacity limitation: Maximum capacity
- Alarm reset required to restart the pump
- Dosing monitoring: Off
- Language: English
- Units: Metric

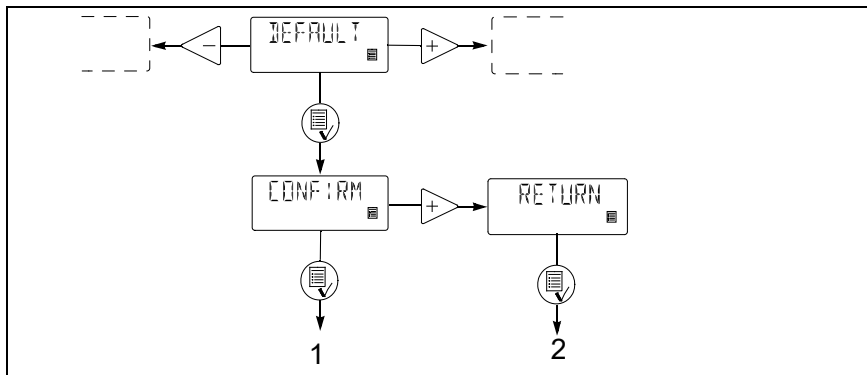

TM077986

Pos.	Description
1	Operating display
2	Operating display without changes

5.19 Return



TM078012

The "RETURN" function makes it possible to return from any level in the menu to the operating display without changes after the menu functions have been used.

5.20 Language

The display text can be displayed in one of the following languages:

- English
- German
- French
- Italian
- Spanish
- Portuguese
- Dutch
- Swedish
- Finnish
- Danish
- Czech
- Slovak
- Polish
- Russian

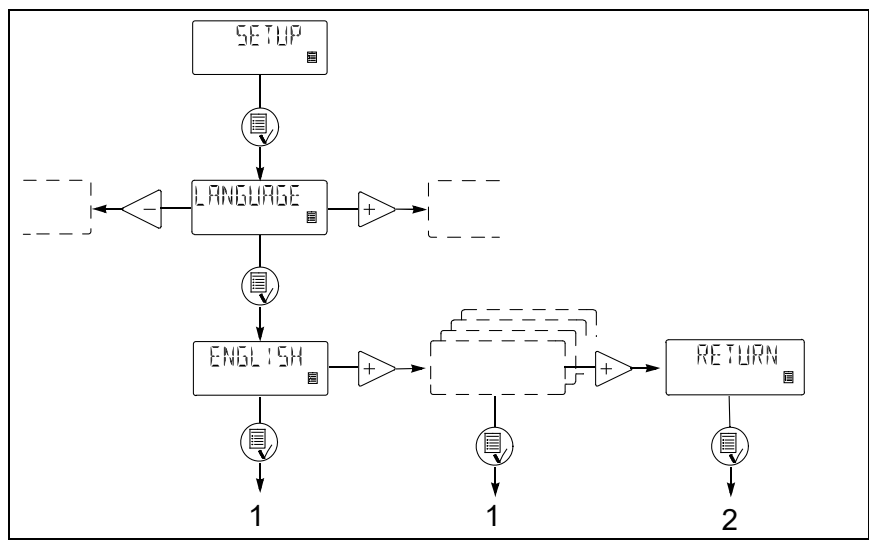

TM077991

Pos.	Description
1	Operating display
2	Operating display without changes

5.21 Input setup

The figure shows all possible settings. The inputs for level, stop dosing and diaphragm leakage can be changed from NO (normally open) to NC (normally closed) function. If changed, the inputs

must be short-circuited in normal operation. The dosing monitoring input can be changed from "OFF" to "ON".

For the analog input, one of the following signal types can be selected:

- 4-20 mA (default)
- 20-4 mA
- 0-20 mA
- 20-0 mA.

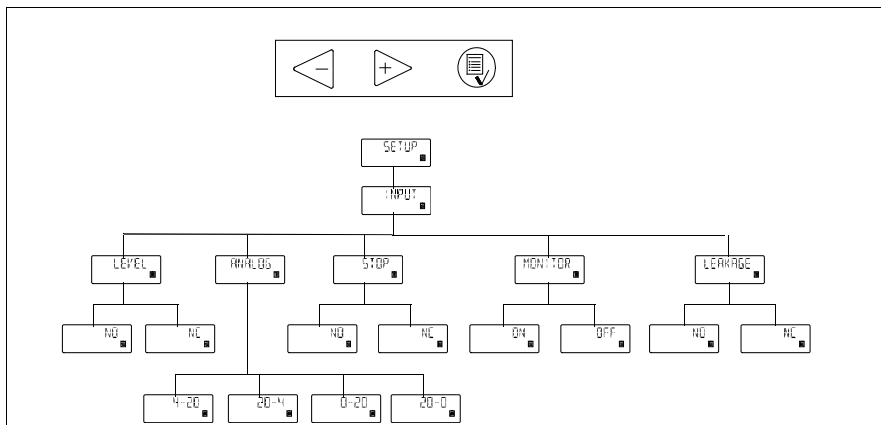

TM077990

Related information

5.12 Analog

5.22 Empty tank (alarm)

The alarm function can be set to "AUT. RES." or "MAN. RES.". This function is used when the level sensor indicates "EMPTY".

The alarm can be reset automatically (AUT. RES.) or manually (MAN. RES.).

For more information about other alarm functions, see section Alarm output and indicator lights.

Related information

5.6 Alarm output and indicator lights

5.23 Measuring units

It is possible to select metric units (litre/millilitre) or US units (gallons).

Metric measuring units:

- **In manual and analog modes**, set the quantity to be dosed in litres per hour (l/h) or millilitres per hour (ml/h).
- **In pulse mode**, set the quantity to be dosed in ml/pulse. The actual capacity is indicated in litres per hour (l/h) or millilitres per hour (ml/h).

- **For calibration**, set the quantity to be dosed in ml per 100 strokes.
- **In timer and batch modes**, set the quantity to be dosed in litres (l) or millilitres (ml).
- Under the "QUANTITY" menu item in the "COUNTERS" menu, the dosed quantity is indicated in litres.

US measuring units:

- **In manual and analog modes**, set the quantity to be dosed in gallons per hour (gph).
- **In pulse mode**, set the quantity to be dosed in ml/pulse. The actual capacity is indicated in gallons per hour (gph).
- **For calibration**, set the quantity to be dosed in ml per 100 strokes.
- **In timer and batch modes**, set the quantity to be dosed in gallons (gal).
- Under the "QUANTITY" menu item in the "COUNTERS" menu, the dosed quantity is indicated in US gallons (gal).

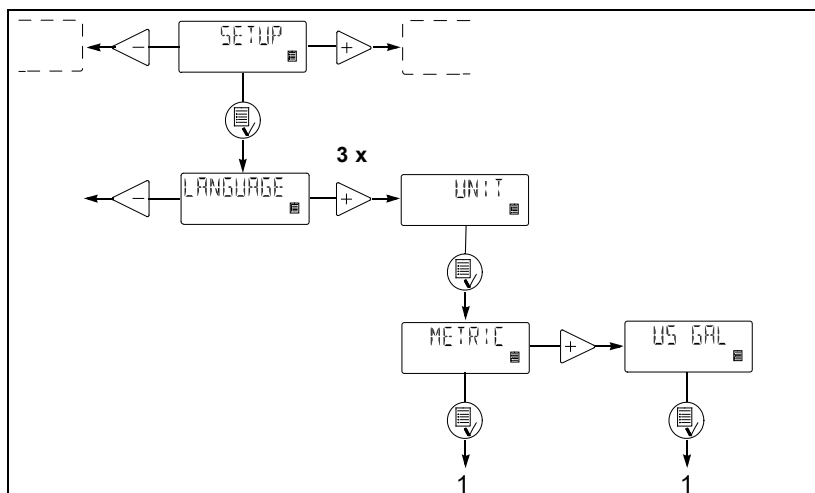

TM077983

Pos.	Description
1	Operating display

5.24 Dosing monitoring

The pump incorporates a dosing monitoring input (see section Connection overview).

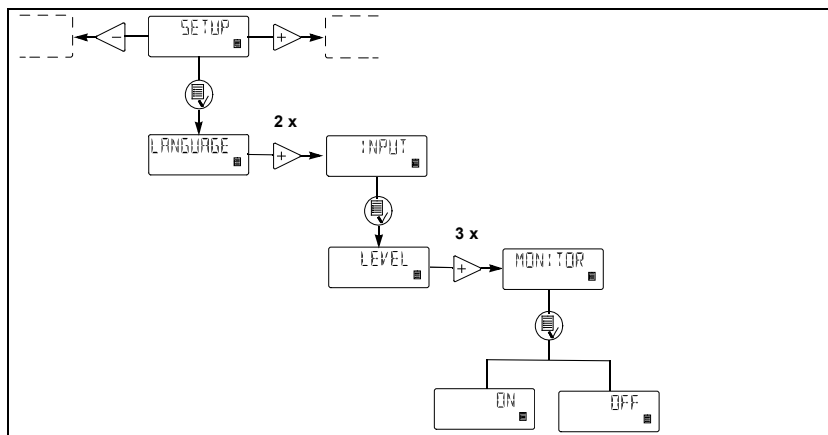

TM077989

The pump can be fitted with a dosing monitor, which detects ineffective dosing strokes.

The dosing monitor is designed to monitor the dosing of liquids which may cause gas accumulation in the dosing head, thus stopping the dosing process even if the pump is still operating.

During the dosing process, the dosing monitor gives pulse signals to the monitor input so that the pump can compare performed dosing strokes (from internal stroke sensor) with externally measured physical strokes (from the dosing monitor). If an external

dosing stroke is not measured as a result of the internal dosing stroke, this is considered a fault that may have been provoked by empty tank or gas in the dosing head.

The dosing monitor should be connected to the input for dosing monitoring. This input must be configured for dosing monitoring. Once the input has been set to dosing monitoring and a dosing monitor has been connected and set, the dosing monitoring function will be active.

Related information

4.6 Connection overview

5.25 Control panel lock

It is possible to lock the buttons on the control panel to prevent malfunction of the pump. The locking function can be set to "ON" or "OFF". The default setting is "OFF".

A PIN code must be entered to change from "OFF" to "ON". When "ON" is selected for the first time, "0000" will appear in the display. If a code has already been entered, it will appear when an attempt to change to "ON" is made. This code can either be re-entered or changed.

If no code has been entered, a code must be set in the same way as the "NX" and "IN" values described in section Timer.

If a code has already been entered, active digits are flashing.

If attempts are made to operate the pump in locked condition, "LOCKED" will appear in the display for 2 seconds, followed by "0000". A code must be entered. If the entering of a code has not been started within 10 seconds, the operating display without changes will appear.

If a wrong code is entered, "LOCKED" will appear in the display for 2 seconds, followed by "0000". A new code must be entered. If the entering of a code has not been started within 10 seconds, the operating display without changes will appear. This display will also appear if the entering of the correct code exceeds 2 minutes.

If the locking function has been activated but the control panel is unlocked, the control panel will be locked automatically if it is not operated for 2 minutes.

The locking function can also be reactivated by selecting "ON" in the "LOCK" menu. The previously entered code will then appear and must be re-entered

by pressing the  button four times. The code can also be changed.

The control panel can be unlocked either by means of the selected code or the factory code 2583.

The following buttons and inputs are still active when the panel is locked:



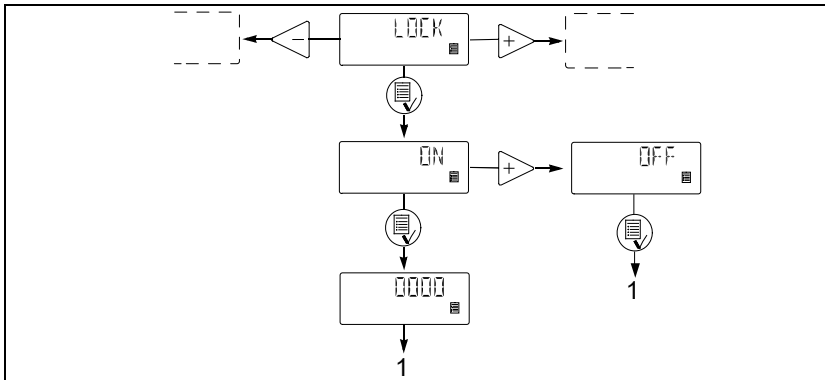



- Priming (-button).
- On/off button.
- All external inputs.



TM077986





Pos.	Description
1	Operating display

Activating the locking function and locking the control panel:

1. Select "LOCK" in the menu.
2. Select "ON" by means of the buttons  and  and confirm with .
3. Enter or re-enter a code by means of the buttons ,  and .

The locking function has now been activated and the control panel is locked.



Unlocking the control panel (without deactivating the locking function):

1. Press  once. "LOCKED" appears in the display for 2 seconds, followed by "0000".
2. Enter the code by means of the buttons ,  and .

* The panel can always be unlocked with code 2583.

The control panel has now been unlocked and will automatically be locked again if the control panel is not operated for 2 minutes.

Deactivating the locking function:

1. Unlock the control panel as described above.
2. Select "LOCK" in the menu.
3. Select "OFF" by means of the buttons  and 
and confirm with .



The locking function has now been deactivated and the control panel is unlocked.

Related information

[5.13 Timer](#)

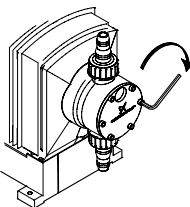
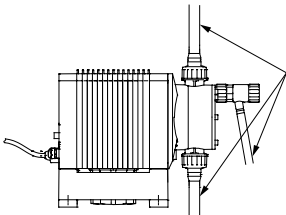
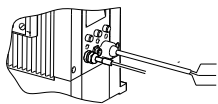
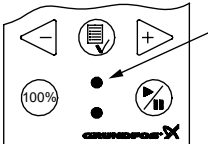
6. Start-up

Step	Action	
1		<p>Prior to start-up, retighten the dosing head screws:</p> <p>Cross-tighten the dosing head screws with a torque wrench once before commissioning and again after 2-5 operating hours at 5.5 Nm (+0.5 / -0 Nm).</p>
2		<p>Connect the hoses/pipes:</p> <p>Connect the suction and dosing tubes/pipes to the pump.</p> <p>Connect a tube to the vent valve, if required, and lead the hose to the tank.</p> <p>Never attach a hose to the drain opening.</p>
3		<p>Connect the cables:</p> <p>Connect the control/level cables, if any, to the pump, see section Connection overview.</p>
4		<p>Switch on the electricity supply:</p> <p>The display is on.</p> <p>The green indicator light is flashing (the pump has stopped).</p> <p>Select language, if required, see section Language.</p>

Step	Action
5	<p>Select the operating mode:</p> <p>Manual. Pulse. Analog. Timer. Batch.</p>
6	<p>Start the pump:</p> <p>Start the pump by pressing the on/off button. The green indicator light is permanently on.</p>
7	<p>Priming/venting:</p> <p>Press the  button on the pump control panel and let the pump run without a counter pressure. Open the vent valve, if required.</p> <p>When the buttons  and  are pressed simultaneously during priming, the pump can be set to run for a specific number of seconds at maximum capacity.</p>
8	<p>Calibration:</p> <p>When the pump has been primed and is running at the right counter pressure, calibrate the pump.</p>

If the pump is not operating satisfactorily, see section Fault finding chart.

Related information

- [4.6 Connection overview](#)
- [5.9 Operating modes](#)
- [5.20 Language](#)
- [7. Calibration](#)
- [9. Fault finding chart](#)

7. Calibration

It is important that the pump is calibrated after installation to ensure that the correct value (ml/h or l/h) appears in the display.

The calibration can be carried out in two different ways:

- **Direct calibration.** The dosed quantity of 100 strokes is measured directly. See section Direct calibration.
- **Check calibration.** See section Check calibration.

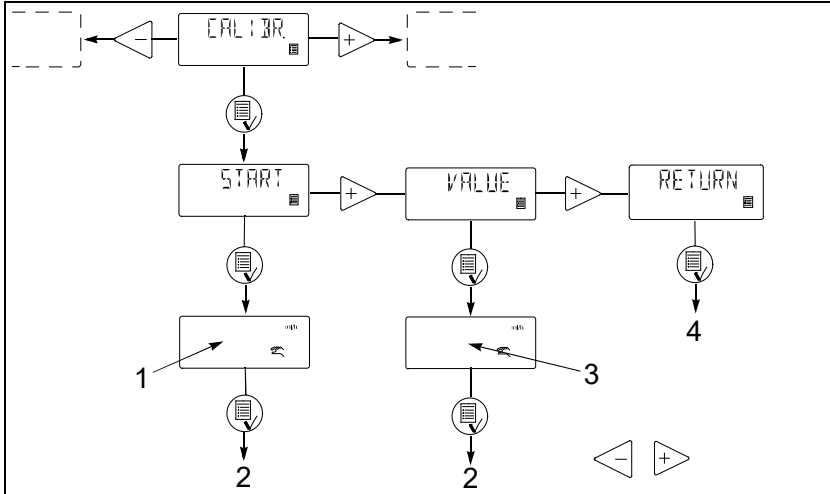

TM077984

Pos.	Description
1	The pump performs 100 dosing strokes
2	Operating display
3	Set value. See section Check calibration
4	Operating display without changes

Related information

- [7.1 Direct calibration](#)
- [7.2 Check calibration](#)

7.1 Direct calibration

Before calibration, make sure that:

- the pump is installed with foot valve, injection valve, etc. in the existing system.
- the pump is running at the counter pressure it is supposed to operate at (adjust the counter pressure valve, if required).
- the pump is operating with the correct suction lift.

To carry out a direct calibration, proceed as follows:

1. Prime the dosing head and the suction tubing.
2. Stop the pump. The green LED is flashing.
3. Fill a graduated glass with dosing liquid, Q_1 .

DME 60: approx. 1.5 l

DME 150: approx. 2.5 l

DME 375: approx. 6 l

DME 940: approx. 14 l

4. Read and note the quantity Q_1 .
5. Place the suction tubing in the graduated glass.

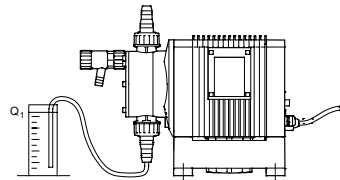

TM027067

6. Go to the calibration menu, see section Menu.
7. Press the button twice.
8. The pump is performing 100 dosing strokes.
9. The factory-calibration value appears in the display.
10. Remove the suction tubing from the graduated glass and read Q_2 .

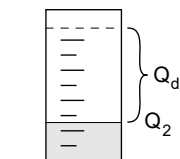

11. Set the display value to $Q_d = Q_1 - Q_2$.
12. Confirm with the  button.
13. The pump is now calibrated and returns to the operating display.

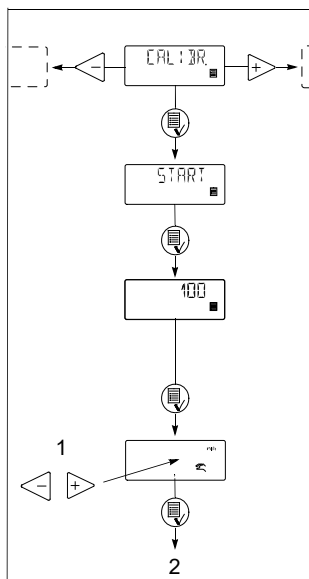

Pump display

Pos.	Description
1	Set value to Q_d
2	Operating display

Related information



[5.8 Menu](#)

7.2 Check calibration

In check calibration, the calibration value is calculated by reading the consumption of chemical in a specific period and comparing this with the number of dosing strokes performed in the same period.

This calibration method is very accurate and especially suitable for check calibration after long periods of operation or if direct calibration is impossible. The calibration can for instance be carried out when the chemical tank is replaced or filled.

To carry out a check calibration, proceed as follows:

1. Stop the pump by pressing the .
2. Read the counter and note the number of dosing strokes, see section Counters.
3. Read and note the quantity in the chemical tank.
4. Start the pump by pressing the  button and let it run for at least 1 hour. The longer the pump is operating, the more accurate the calibration will be.
5. Stop the pump by pressing the .
6. Read the counter and note the number of dosing strokes, see section Counters.
7. Read and note the quantity in the chemical tank.
8. Calculate the dosed quantity in ml and the number of dosing strokes performed during the operating period.
9. Calculate the calibration value as follows: (dosed quantity in ml/dosing strokes) x 100.
10. Set the calculated value in the calibration menu.

Related information

[5.17 Counters](#)

TM019361

TM077988

8. Service

In order to ensure a long service life and dosing accuracy, wearing parts such as diaphragms and valves must be regularly checked for signs of wear. Where necessary, replace worn parts with original spare parts made from suitable materials.

Should you have any questions, please contact your service partner.

8.1 Regular maintenance

Interval	Task
Daily	<p>Check, if liquid leaks from the drain opening (see section Installation of pump) and if the drain opening is blocked or soiled.</p> <p>If so, follow the instructions given in section Diaphragm leakage.</p> <p>Check, if liquid leaks from the dosing head or valves.</p> <p>If the pump was operated with damaged or loose dosing head screws, immediately separate the pump from the power supply! Follow the instructions given in section Operation with loose dosing head screws.</p> <p>If necessary, tighten valves and cap nuts, or perform service.</p>
Weekly	<p>Clean all pump surfaces with a dry and clean cloth.</p> <p>Check dosing head screws.</p> <p>If necessary, cross-tighten dosing head screws with a torque wrench at 5.5 Nm (+0.5 / -0 Nm). Replace damaged screws immediately.</p>
Every 3 months	<p>Replace diaphragm and valves (see section Perform service)</p>
Every 2 years or 8000 operating hours*	<p>Replace diaphragm and valves (see section Perform service)</p>

* For media which result in increased wear, the service interval must be shortened.

Related information

- [1.7 Operation with loose dosing head screws](#)
- [4.3 Installation of pump](#)
- [8.3 Perform service](#)
- [8.4 Diaphragm breakage](#)

8.2 Cleaning

If necessary, clean all pump surfaces with a dry and clean cloth.

8.3 Perform service

Only spare parts and accessories from Grundfos should be used for maintenance. The usage of non-original spare parts and accessories renders any liability for resulting damages null and void.

Further information about carrying out maintenance can be found in the service kit catalog on our homepage (www.grundfos.com).

Warning

Risk of chemical burns!

When dosing dangerous media, observe the corresponding precautions in the safety data sheets!

Wear protective clothing (gloves and goggles) when working on the dosing head, connections or lines!

Do not allow any chemicals to leak from the pump. Collect and dispose of all chemicals correctly!

Before any work to the pump, the pump must be disconnected from the power supply. The system must be pressureless!



Caution

8.3.1 Dosing head overview

Example without deaeration valve.

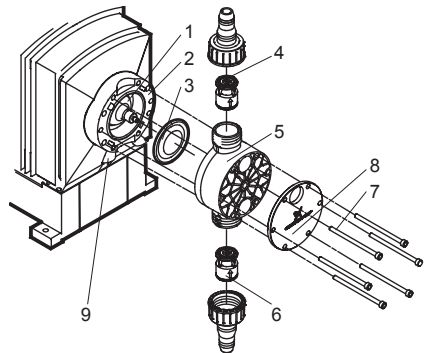

TMC60018

Dosing head, exploded view

Pos.	Description
1	Safety diaphragm
2	Flange
3	Diaphragm
4	Valve on discharge side
5	Dosing head

Pos.	Description
6	Valve on suction side
7	Screws
8	Dosing head front plate (only PP, PVDF)
9	Drain opening

8.3.2 Dismantling the diaphragm and valves

Before dismantling, read section Diaphragm breakage and section Operation with loose dosing head screws thoroughly.



Warning

Danger of explosion, if dosing liquid has entered the pump housing!

If the diaphragm is possibly damaged or if the pump was operated with damaged or loose dosing head screws, don't connect the pump to the power supply!

This section refers to fig. Dosing head, exploded view.

1. Make system pressureless.
2. Empty the dosing head before maintenance and flush it, if necessary.
3. Take suitable steps to ensure that the returning liquid is safely collected.
4. Dismantle suction, pressure and deaeration hoses.
5. Unscrew deaeration valve.
6. Dismantle valves on suction and discharge side (4, 6).
7. Loosen screws (7) on the dosing head (5).
8. Remove the screws, in case of PP or PVDF dosing head together with the front plate (8).
9. Remove the dosing head (5).
10. Unscrew diaphragm (3) counter-clockwise and remove it.
11. Make sure the drain opening (9) is not blocked or soiled. Clean if necessary.
12. Check the safety diaphragm (1) for wear and damage.

If nothing indicates that dosing liquid has entered the pump housing, and if the safety diaphragm is not worn or damaged, go on as described in section Reassembling the diaphragm and valves. Otherwise proceed as described in section Dosing liquid in the pump housing.

Related information

- [1.7 Operation with loose dosing head screws](#)
- [8.3.1 Dosing head overview](#)
- [8.3.3 Reassembling the diaphragm and valves](#)
- [8.4 Diaphragm breakage](#)
- [8.4.1 Dosing liquid in the pump housing](#)

8.3.3 Reassembling the diaphragm and valves

Caution Please observe as well sections Installation, Priming/venting of pump and Start-up!

The pump must only be reassembled, if nothing indicates that dosing liquid has entered the pump housing. Otherwise proceed as described in section Dosing liquid in the pump housing.

This section refers to fig. Dosing head, exploded view.

1. Screw on new diaphragm (3) clockwise.
2. Attach the dosing head (5).
3. Install screws (7), in case of PP or PVDF dosing head together with the front plate (8), and cross-tighten with a torque wrench.
 - Torque: 5.5 Nm (+0.5 / -0 Nm).
4. Install new valves (4, 6).
 - Observe the flow direction (indicated by an arrow on the valve)!
5. Install the deaeration valve.
6. Connect suction, pressure and deaeration hoses.

Caution Cross-tighten the dosing head screws with a torque wrench once before commissioning and again after 2-5 operating hours at 5.5 Nm (+0.5 / -0 Nm).

7. Deaerate dosing pump (see section Priming/venting of pump)

Related information

- [4.1 Safety instructions](#)
- [5.3 Priming/venting of pump](#)
- [6. Start-up](#)
- [8.3.1 Dosing head overview](#)
- [8.4.1 Dosing liquid in the pump housing](#)

8.4 Diaphragm breakage

This section refers to figure Dosing head, exploded view in section Dosing head overview.

If the diaphragm leaks or is broken, dosing liquid escapes from the drain opening (fig. Dosing head, exploded view, pos. 9) on the dosing head flange.

In case of diaphragm breakage, the safety diaphragm (pos. 1) protects the pump housing against ingress of dosing liquid.

When dosing crystallising liquids the drain opening can be blocked by crystallisation. If the pump is not taken out of operation immediately, a pressure can build up between the diaphragm (pos. 3) and the safety diaphragm in the flange (pos. 1). The pressure can press dosing liquid through the safety diaphragm into the pump housing.

Most dosing liquids don't cause any danger when entering the pump housing. However a view liquids can cause a chemical reaction with inner parts of the pump. In the worst case, this reaction can produce explosive gases in the pump housing.

Warning

Danger of explosion, if dosing liquid has entered the pump housing!

Operation with damaged diaphragm can lead to dosing liquid entering the pump housing.



In case of diaphragm breakage, immediately separate the pump from the power supply!

Make sure the pump cannot be put back into operation by accident!

Dismantle the dosing head without connecting the pump to the power supply and make sure no dosing liquid has entered the pump housing. Proceed as described in section Dismantling the diaphragm and valves.

To avoid any danger resulting from diaphragm breakage, observe the following:

- Perform regular maintenance.
- Never operate the pump with blocked or soiled drain opening.
 - If the drain opening is blocked or soiled, proceed as described in section Dismantling the diaphragm and valves.
- Never attach a hose to the drain opening. If a hose is attached to the drain opening, it is impossible to recognise escaping dosing liquid.
- Take suitable precautions to prevent harm to health and damage to property from escaping dosing liquid.
- Never operate the pump with damaged or loose dosing head screws.

Related information

[8.1 Regular maintenance](#)

[8.3.2 Dismantling the diaphragm and valves](#)

[8.3.1 Dosing head overview](#)

8.4.1 Dosing liquid in the pump housing

Warning

Danger of explosion!



Immediately separate the pump from the power supply!

Make sure the pump cannot be put back into operation by accident!

If dosing liquid has entered the pump housing, or if the safety diaphragm is damaged or worn:

- Send the pump to Grundfos for repair, following the instructions given in section Repairs.
- If a repair isn't economically reasonable, dispose of the pump observing the information in section Disposing of the product.

Related information

[8.6 Repairs](#)

[10. Disposing of the product](#)

8.5 Operation with loose dosing head screws

Warning

Danger of explosion, if dosing liquid has entered the pump housing!

Operation with damaged or loose dosing head screws can lead to dosing liquid entering the pump housing.



If the pump was operated with damaged or loose dosing head screws, immediately separate the pump from the power supply!

Make sure the pump cannot be put back into operation by accident!

Dismantle the dosing head without connecting the pump to the power supply and make sure no dosing liquid has entered the pump housing. Proceed as described in section Dismantling the diaphragm and valves.

Related information

[8.3.2 Dismantling the diaphragm and valves](#)

8.6 Repairs

Warning



The pump housing must only be opened by personnel authorised by Grundfos!

Repairs must only be carried out by authorised and qualified personnel!

Switch off the pump and disconnect it from the voltage supply before carrying out maintenance work and repairs!

Note

The replacement of the supply cable must be carried out by an authorised Grundfos service workshop.

After consulting Grundfos, please send the pump, together with the safety declaration completed by a specialist, to Grundfos. The safety declaration can be found at the end of these instructions. It must be copied, completed and attached to the pump.

The pump must be cleaned prior to dispatch!

Caution

If dosing liquid has possibly entered the pump housing, state that explicitly in the safety declaration! Observe section Diaphragm breakage.

If the above requirements are not met, Grundfos may refuse to accept delivery of the pump. The shipping costs will be charged to the sender.

Related information

[8.4 Diaphragm breakage](#)

9. Fault finding chart

Fault	Cause	Remedy
The dosing has stopped or the output is too low.	Valves leaking or blocked.	Check and clean the valves.
	Valves incorrectly installed.	Remove and fit valves. Check that the arrow on the valve casing is pointing in the liquid flow direction. Check that all O-rings have been fitted correctly.
	Suction valve or suction pipe/hose leaking or blocked.	Clean and seal the suction pipe/hose.
	Suction lift too high.	Install the pump in a lower position. Install a priming tank.
	Viscosity too high.	Select the anti-cavitation function, see section Anti-cavitation. Install a pipe/hose with larger cross-section. Fit spring-loaded valves.
Pump out of calibration.	Calibrate the pump, see section Calibration.	
Pump dosing too little or too much.	Pump out of calibration.	Calibrate the pump, see section Calibration.
Pump dosing irregularly.	Valves leaking or blocked.	Check and clean the valves.
Leakage from drain hole.	Diaphragm defective.	Install a new diaphragm.
	Diaphragm not fastened properly.	Install a new diaphragm and ensure that the diaphragm is fastened properly.
Frequent diaphragm failures.	Counter-pressure too high (measured at the pump discharge port).	Check the system. Check the injection valve.
	Sediment in dosing head.	Clean/flush the dosing head.

Related information

[5.15 Anti-cavitation](#)

[7. Calibration](#)

10. Disposing of the product

This product or parts of it must be disposed of in an environmentally sound way.

1. Use the public or private waste collection service.
2. If this is not possible, contact the nearest Grundfos company or service workshop.



The crossed-out wheeled bin symbol on a product means that it must be disposed of separately from household waste. When a product marked with this symbol reaches its end of life, take it to a collection point designated by the local waste disposal authorities. The separate collection and recycling of such products will help protect the environment and human health.

See also end-of-life information at www.grundfos.com/product-recycling.

Dimensions

1. Dimensions

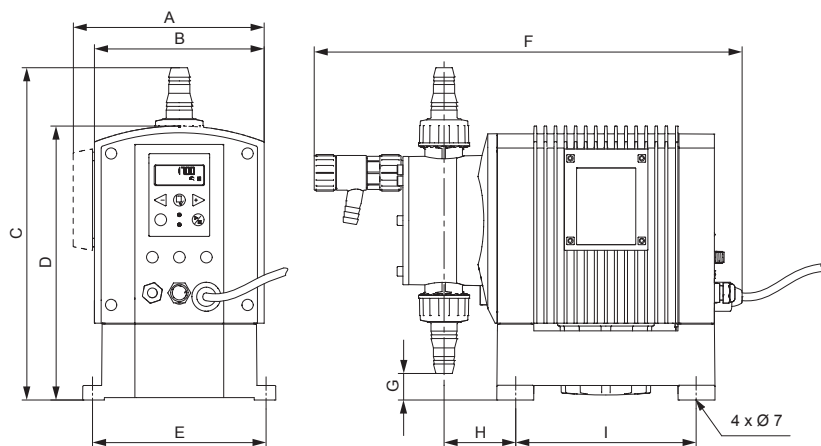

TM027062

	DME 60	DME 150	DME 375	DME 940
A = [mm]	176	176	238	238
B = [mm]	198	198	218	218
C = [mm]	331	345	471	496
D = [mm]	284	284	364	364
E = [mm]	180	180	230	230
F = [mm]	444	444	540	539
G = [mm]	41	28	31	6
H = [mm]	74	74	95	95
I = [mm]	187	187	246	246

Argentina

Bombas GRUNDFOS de Argentina S.A.
Ruta Panamericana km. 37.500/Industin
1610 - Garin Pcia. de B.A.
Tel.: +54-3327 414 444
Fax: +54-3327 45 3190

Australia

GRUNDFOS Pumps Pty. Ltd.
P.O. Box 2040
Regency Park
South Australia 5942
Tel.: +61-8-8461-4611
Fax: +61-8-8340-0155

Austria

GRUNDFOS Pumpen Vertrieb
Ges.m.b.H.
Grundfosstraße 2
A-5082 Grödig/Salzburg
Tel.: +43-6246-883-0
Fax: +43-6246-883-30

Belgium

N.V. GRUNDFOS Bellux S.A.
Boomssesteenweg 81-83
B-2630 Aartselaar
Tel.: +32-3-870 7300
Fax: +32-3-870 7301

Belarus

Представительство ГРУНДФОС в
Минске
220125, Минск
ул. Шафарнянская, 11, оф. 56, БЦ
«Порт»
Тел.: +375 17 397 397 3
+375 17 397 397 4
Факс: +375 17 397 397 1
E-mail: minsk@grundfos.com

Bosnia and Herzegovina

GRUNDFOS Sarajevo
Zmaja od Bosne 7-7A
BiH-71000 Sarajevo
Tel.: +387 33 592 480
Fax: +387 33 590 465
www.ba.grundfos.com
E-mail: grundfos@bih.net.ba

Brazil

BOMBAS GRUNDFOS DO BRASIL
Av. Humberto de Alencar Castelo
Branco, 630
CEP 09850 - 300
São Bernardo do Campo - SP
Tel.: +55-11 4393 5533
Fax: +55-11 4343 5015

Bulgaria

Grundfos Bulgaria EOOD
Slatina District
Iztocna Tangenta street no. 100
BG - 1592 Sofia
Tel.: +359 2 49 22 200
Fax: +359 2 49 22 201
E-mail: bulgaria@grundfos.bg

Canada

GRUNDFOS Canada inc.
2941 Brighton Road
Oakville, Ontario
L6H 6C9
Tel.: +1-905 829 9533
Fax: +1-905 829 9512

China

GRUNDFOS Pumps (Shanghai) Co. Ltd.
10F The Hub, No. 33 Suhong Road
Minhang District
Shanghai 201106 PRC
Tel.: +86 21 612 252 22
Fax: +86 21 612 253 33

Columbia

GRUNDFOS Colombia S.A.S.
Km 1.5 via Siberia-Cota Conj. Potrero
Chico,
Parque Empresarial Arcos de Cota Bod.
1A.
Cota, Cundinamarca
Tel.: +57(1)-2913444
Fax: +57(1)-8764586

Croatia

GRUNDFOS CROATIA d.o.o.
Buzinski prilaz 38, Buzin
HR-10010 Zagreb
Tel.: +385 1 6595 400
Fax: +385 1 6595 499
www.hr.grundfos.com

Czech Republic

GRUNDFOS Sales Czechia and Slovakia
s.r.o.
Čajkovského 21
779 00 Olomouc
Tel.: +420-585-716 111

Denmark

GRUNDFOS DK A/S
Martin Bachs Vej 3
DK-8850 Bjerringbro
Tel.: +45-87 50 50 50
Fax: +45-87 50 51 51
E-mail: info_GDK@grundfos.com
www.grundfos.com/DK

Estonia

GRUNDFOS Pumps Eesti OÜ
Peterburi tee 92G
11415 Tallinn
Tel.: + 372 606 1690
Fax: + 372 606 1691

Finland

OY GRUNDFOS Pumput AB
Trukkikuja 1
FI-01360 Vantaa
Tel.: +358-(0) 207 889 500

France

Pompes GRUNDFOS Distribution S.A.
Parc d'Activités de Chesnes
57, rue de Malacombe
F-38290 St. Quentin Fallavier (Lyon)
Tel.: +33-4 74 82 15 15
Fax: +33-4 74 94 10 51

Germany

GRUNDFOS GMBH
Schlüterstr. 33
40699 Erkrath
Tel.: +49-(0) 211 929 69-0
Fax: +49-(0) 211 929 69-3799
E-mail: infoservice@grundfos.de
Service in Deutschland:
kundendienst@grundfos.de

Greece

GRUNDFOS Hellas A.E.B.E.
20th km. Athinon-Markopoulou Av.
P.O. Box 71
GR-19002 Peania
Tel.: +0030-210-66 83 400
Fax: +0030-210-66 46 273

Hong Kong

GRUNDFOS Pumps (Hong Kong) Ltd.
Unit 1, Ground floor, Siu Wai industrial
Centre
29-33 Wing Hong Street & 68 King Lam
Street, Cheung Sha Wan
Kowloon
Tel.: +852-27861706 / 27861741
Fax: +852-27858664

Hungary

GRUNDFOS Hungária Kft.
Tópark u. 8
H-2045 Törökbalint
Tel.: +36-23 511 111
Fax: +36-23 511 111

India

GRUNDFOS Pumps india Private Limited
118 Old Mahabalipuram Road
Thoraiakkam
Chennai 600 097
Tel.: +91-44 2496 6800

Indonesia

PT GRUNDFOS Pompa
Graha intirub Lt. 2 & 3
Jln. Cililitan Besar No.454, Makasar,
Jakarta Timur
ID-Jakarta 13650
Tel.: +62 21-469-51900
Fax: +62 21-460 6910 / 460 6901

Ireland

GRUNDFOS (Ireland) Ltd.
Unit A, Merrywell Business Park
Ballymount Road Lower
Dublin 12
Tel.: +353-1-4089 800
Fax: +353-1-4089 830

Italy

GRUNDFOS Pompe Italia S.r.l.
Via Gran Sasso 4
I-20060 Truccazzano (Milano)
Tel.: +39-02-95838112
Fax: +39-02-95309290 / 95838461

Japan

GRUNDFOS Pumps K.K.
1-2-3, Shin-Miyakoda, Kita-ku
Hamamatsu
431-2103 Japan
Tel.: +81 53 428 4760
Fax: +81 53 428 5005

Korea

GRUNDFOS Pumps Korea Ltd.
6th Floor, Aju Building 679-5
Yeoksam-dong, Kangnam-ku, 135-916
Seoul, Korea
Tel.: +82-2-5317 600
Fax: +82-2-5633 725

Latvia

SIA GRUNDFOS Pumps Latvia
 Deglava biznesa centrs
 Augusta Deglava ielā 60
 LV-1035, Rīga,
 Tel.: + 371 714 9640, 7 149 641
 Fax: + 371 914 9646

Lithuania

GRUNDFOS Pumps UAB
 Smolensko g. 6
 LT-03201 Vilnius
 Tel.: + 370 52 395 430
 Fax: + 370 52 395 431

Malaysia

GRUNDFOS Pumps Sdn. Bhd.
 7 Jalan Peguam U/125
 Glenmarie Industrial Park
 40150 Shah Alam, Selangor
 Tel.: +60-3-5569 2922
 Fax: +60-3-5569 2866

Mexico

Bombas GRUNDFOS de México
 S.A. de C.V.
 Boulevard TLC No. 15
 Parque industrial Stiva Aeropuerto
 Apodaca, N.L. 66600
 Tel.: +52-81-8144 4000
 Fax: +52-81-8144 4010

Netherlands

GRUNDFOS Netherlands
 Veluwezoom 35
 1326 AE Almere
 Postbus 22015
 1302 CA ALMERE
 Tel.: +31-88-478 6336
 Fax: +31-88-478 6332
 E-mail: info_gnl@grundfos.com

New Zealand

GRUNDFOS Pumps NZ Ltd.
 17 Beatrice Tinsley Crescent
 North Harbour Industrial Estate
 Albany, Auckland
 Tel.: +64-9-415 3240
 Fax: +64-9-415 3250

Norway

GRUNDFOS Pumper A/S
 Strømsveien 344
 Postboks 235, Leirdal
 N-1011 Oslo
 Tel.: +47-22 90 47 00
 Fax: +47-22 32 21 50

Poland

GRUNDFOS Pompy Sp. z o.o.
 ul. Klonowa 23
 Baranowo k. Poznania
 PL-62-081 Przemierowo
 Tel.: (+48-61) 650 13 00
 Fax: (+48-61) 650 13 50

Portugal

Bombas GRUNDFOS Portugal, S.A.
 Rua Calvet de Magalhães, 241
 Apartado 1079
 P-2770-153 Paço de Arcos
 Tel.: +351-21-440 76 00
 Fax: +351-21-440 76 90

Romania

GRUNDFOS Pompe România SRL
 S-PARK BUSINESS CENTER, Clădirea
 A2, etaj 2
 Str. Tipografilor, Nr. 11-15, Sector 1, Cod
 013714
 Bucuresti, Romania
 Tel.: 004 021 2004 100
 E-mail: romania@grundfos.ro

Russia

ООО Грундфос Россия
 ул. Школьная, 39-41
 Москва, RU-109544, Russia
 Тел. (+7) 495 564-88-00 (495) 737-30-00
 Факс (+7) 495 564 8811
 E-mail grundfos.moscow@grundfos.com

Serbia

Grundfos Srbija d.o.o.
 Omladinskih brigada 90b
 11070 Novi Beograd
 Tel.: +381 11 2258 740
 Fax: +381 11 2281 769
 www.rs.grundfos.com

Singapore

GRUNDFOS (Singapore) Pte. Ltd.
 25 Jalan Tukang
 Singapore 619264
 Tel.: +65-6681 9688
 Fax: +65-6681 9689

Slovakia

GRUNDFOS s.r.o.
 Prievozská 4D 821 09 BRATISLAVA
 Tel.: +421 2 5020 1426
 sk.grundfos.com

Slovenia

GRUNDFOS LJUBLJANA, d.o.o.
 Leskoškova 9e, 1122 Ljubljana
 Tel.: +386 (0) 1 568 06 10
 Fax: +386 (0)1 568 06 19
 E-mail: tehnika-si@grundfos.com

South Africa

GRUNDFOS (PTY) LTD
 16 Lascelles Drive, Meadowbrook Estate
 1609 Germiston, Johannesburg
 Tel.: (+27) 10 248 6000
 Fax: (+27) 10 248 6002
 E-mail: lgradidge@grundfos.com

Spain

Bombas GRUNDFOS España S.A.
 Camino de la Fuentesilla, s/n
 E-28110 Algete (Madrid)
 Tel.: +34-91-848 8800
 Fax: +34-91-628 0465

Sweden

GRUNDFOS AB
 Box 333 (Lunnagårdsgatan 6)
 431 24 Mölndal
 Tel.: +46 31 332 23 000
 Fax: +46 31 331 94 60

Switzerland

GRUNDFOS Pumpen AG
 Bruggacherstrasse 10
 CH-8117 Fällanden/ZH
 Tel.: +41-44-806 8111
 Fax: +41-44-806 8115

Taiwan

GRUNDFOS Pumps (Taiwan) Ltd.
 7 Floor, 219 Min-Chuan Road
 Taichung, Taiwan, R.O.C.
 Tel.: +886-4-2305 0868
 Fax: +886-4-2305 0878

Thailand

GRUNDFOS (Thailand) Ltd.
 92 Chalome Phrakiat Rama 9 Road
 Dokmai, Pravej, Bangkok 10250
 Tel.: +66-2-725 8999
 Fax: +66-2-725 8998

Turkey

GRUNDFOS POMPA San. ve Tic. Ltd.
 Sti.
 Gebze Organize Sanayi Bölgesi
 Ihsan dede Caddesi
 2. yol 200. Sokak No, 204
 41490 Gebze/ Kocaeli
 Tel.: +90 - 262-679 7979
 Fax: +90 - 262-679 7905
 E-mail: satis@grundfos.com

Ukraine

ТОВ "ГРУНДФОС УКРАЇНА"
 Бізнес Центр Європа
 Столицне шосе, 103
 м. Київ, 03131, Україна
 Tel.: (+38 044) 237 04 00
 Fax: (+38 044) 237 04 01
 E-mail: ukraine@grundfos.com

United Arab Emirates

GRUNDFOS Gulf Distribution
 P.O. Box 16768
 Jebel Ali Free Zone, Dubai
 Tel.: +971 4 8815 166
 Fax: +971 4 8815 136

United Kingdom

GRUNDFOS Pumps Ltd.
 Grovebury Road
 Leighton Buzzard/Beds. LU7 4TL
 Tel.: +44-1525-850000
 Fax: +44-1525-850011

U.S.A.

Global Headquarters for WU
 856 Koomey Road
 Brookshire, Texas 77423 USA
 Phone: +1-630-236-5500

Uzbekistan

Grundfos Tashkent, Uzbekistan
 The Representative Office of Grundfos
 Kazakhstan in Uzbekistan
 38a, Oybek street, Tashkent
 Tel.: (+998) 71 150 3290 / 71 150 3291
 Fax: (+998) 71 150 3292

99301274 09.2022

ECM: 1322072

www.grundfos.com

GRUNDFOS 

Trademarks displayed in this material, including but not limited to Grundfos and the Grundfos logo, are registered trademarks owned by The Grundfos Group. © 2022 Grundfos Holding A/S, all rights reserved.