



UPA

15-90 / 15-120 / 15-160



最大承压：1兆帕
(10巴)



最小/最大介质温度：
2/95摄氏度



最小/最大环境温度：
2/40摄氏度



UPA 15-90



UPA 15-120



UPA 15-160





噪声 < 43 杜比



最大相对湿度：95%
防护等级：IPX2D

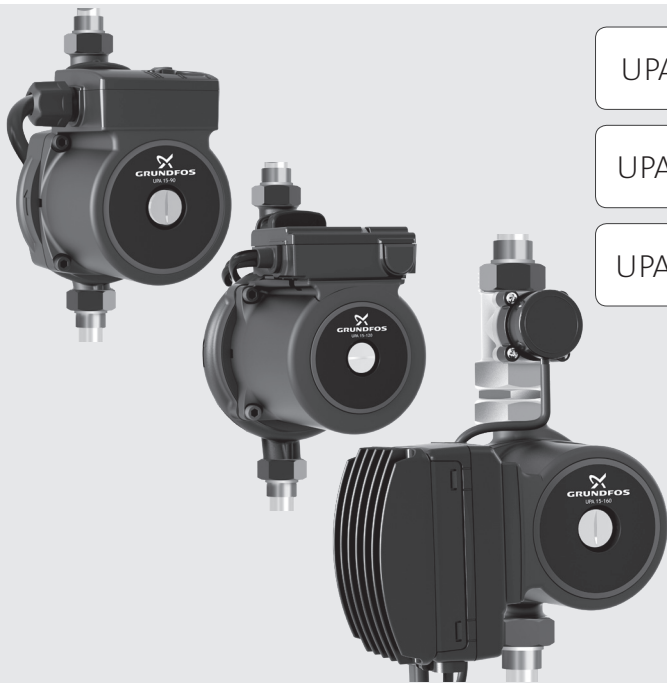

UPA 15-90

UPA 15-120

UPA 15-160

1

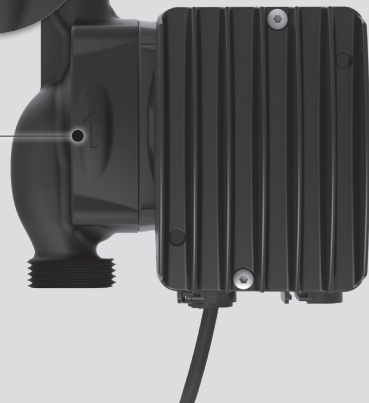

UPA 15-90

UPA 15-120

UPA 15-160

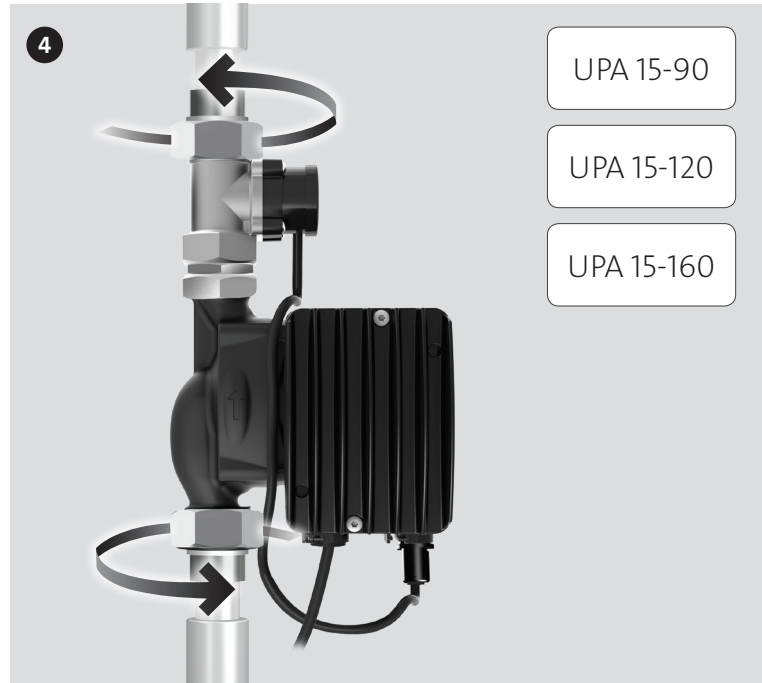
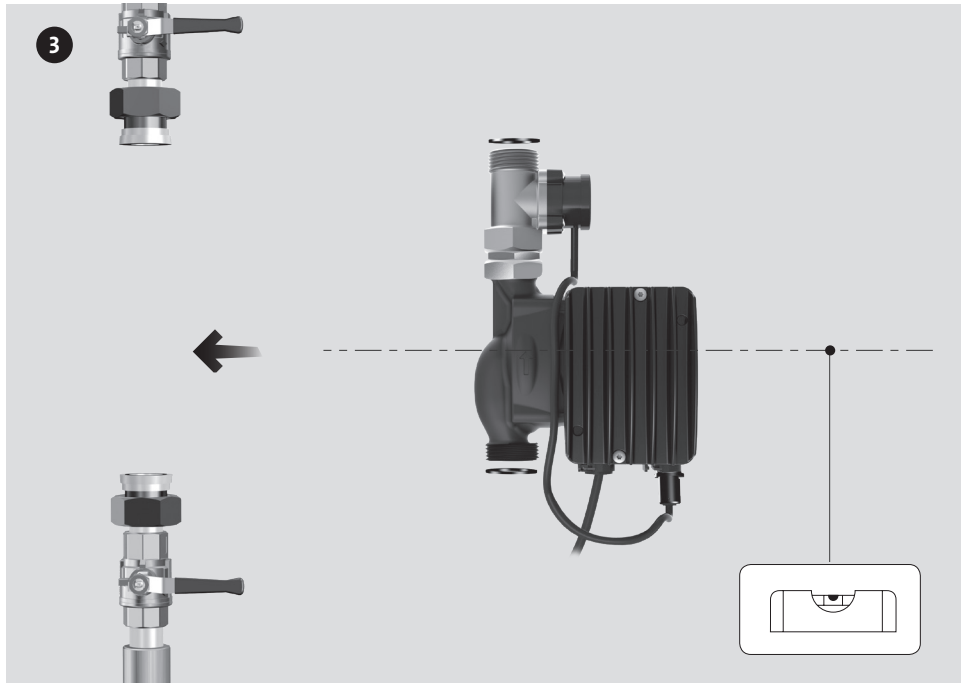
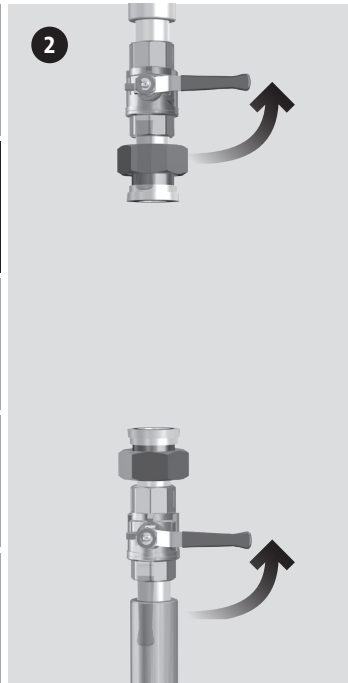



UPA 15-90



UPA 15-120



UPA 15-160

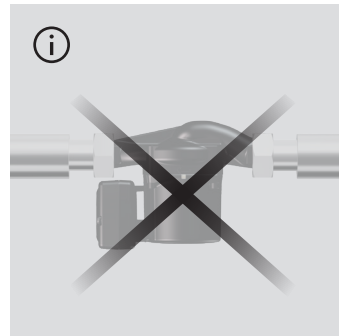
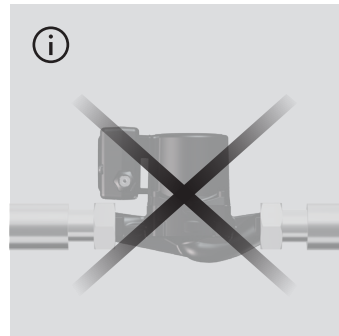
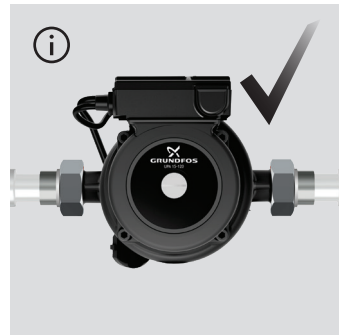
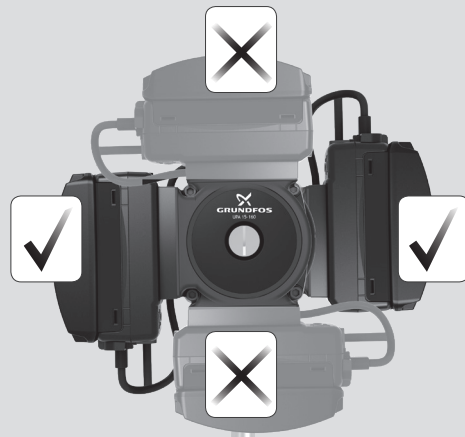



UPA 15-120

UPA 15-160





5

UPA 15-90

UPA 15-120

UPA 15-160

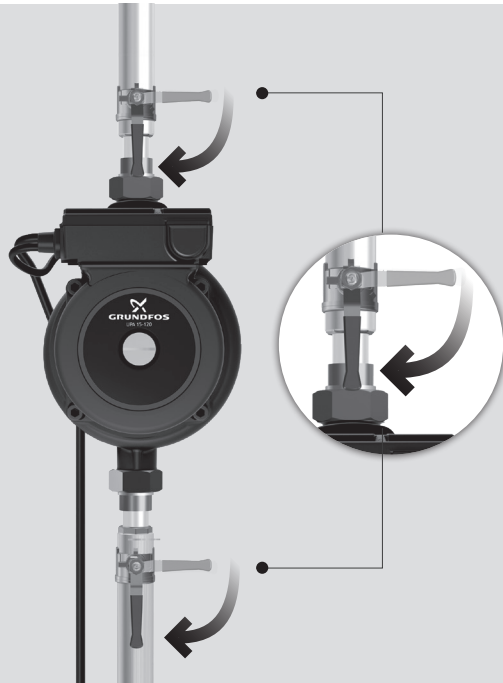

6



1/On

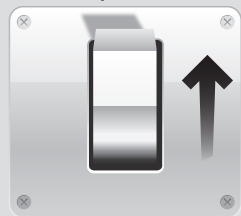

0/Off

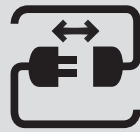
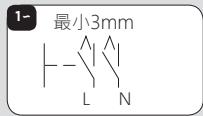

7



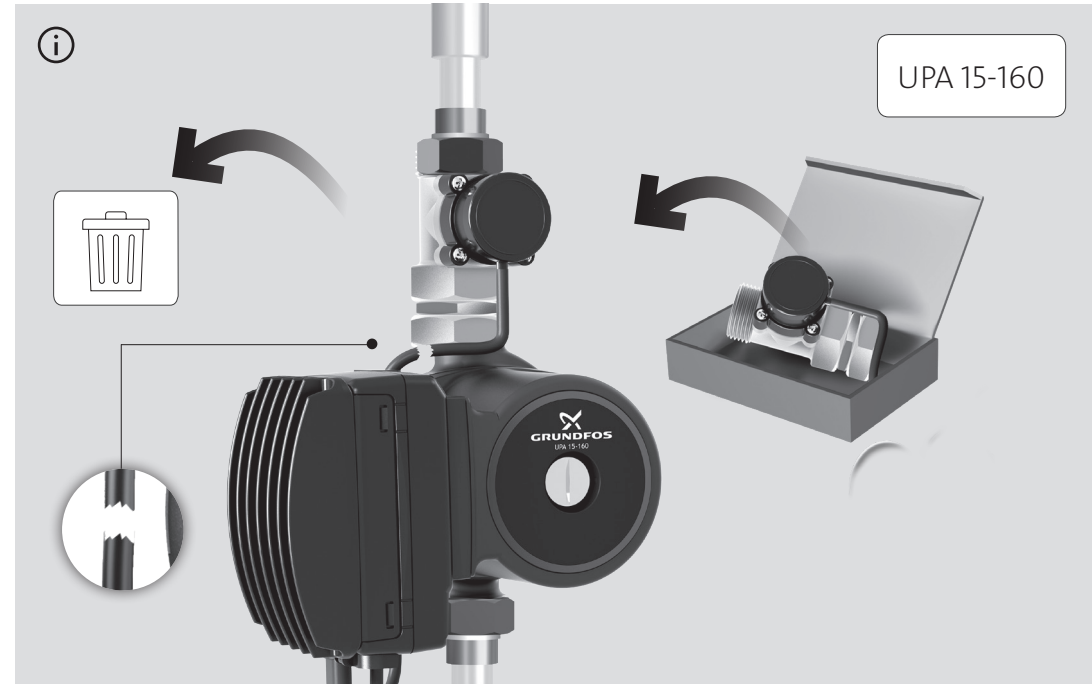
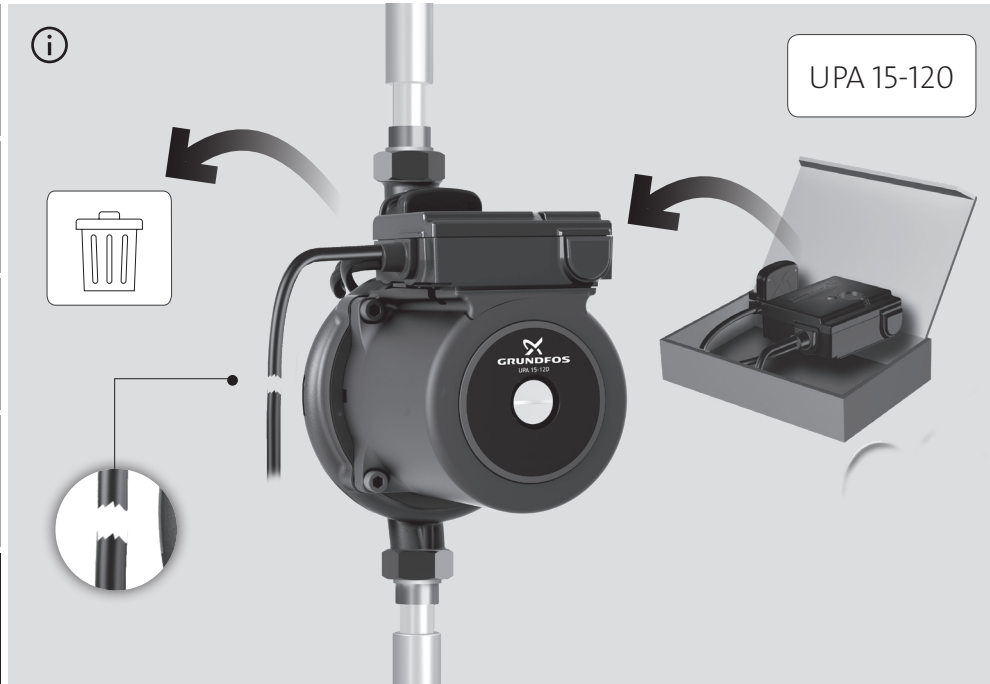





中国：欧盟合格声明

我们格兰富在我们的全权责任下声明，产品 UPA，即该合格证所指之产品，符合欧共体使其成员国法律趋于一致的以下欧共理事会指令：

低电压指令 (2014/35/EU)。

所用标准：
EN 60335-1:2012

电磁兼容性指令 (2014/30/EU)。

所用标准：
EN 55014-1:2006
EN 55014-2:2015

中国
警告

使用该产品需要一定的产品常识和经验。除非在现场监护或指导下，肢体、感官或精神缺陷、失能者请勿使用本产品，该监护人或指导者需对使用者安全负责。儿童不得使用或玩耍本产品。

产品中有害物质的名称及含量

部件名称	有害物质					
	铅	汞	镉	六价铬	多溴联苯	多溴联苯醚
泵壳	X	○	○	○	○	○
印刷电路板	X	○	○	○	○	○

本表格依据 SJ/T 11364 的规定编制

○：表示该有害物质在该部件所有均质材料中的含量均在 GB/T 26572 规定的限量要求以下。

X：表示该有害物质至少在该部件的某一均质材料中的含量超出 GB/T 26572 该规定的限量要求。



该产品环保使用期限为 10 年，标识如左图所示。

此环保期限只适用于产品在安装与使用说明书中所规定的条件下工作

be think innovate

中国
格兰富水泵（上海）有限公司
上海办公室
地址：上海市闵行区苏虹路33号
虹桥天地3号楼10层 201106
电话：400 920 6655

99357444 0118

ECM: 1221827

GRUNDFOS 

The name Grundfos, the Grundfos logo, and be think innovate are registered trademarks owned by Grundfos Holding A/S or Grundfos A/S, Denmark. All rights reserved worldwide.