

TP, TPD

Installation and operating instructions



TP TPD

Installation and operating instructions
(all available languages)
<http://net.grundfos.com/qr/i/96404999>

TP, TPD

English (GB)

Installation and operating instructions	4
Appendix A	25
Appendix B	47

English (GB) Installation and operating instructions

Original installation and operating instructions

Table of contents

1. General information	4
1.1 Hazard statements	4
1.2 Notes	4
2. Product introduction	5
2.1 Product description	5
2.2 Identification	5
2.3 Applications	8
3. Receiving the product	9
3.1 Delivery	9
4. Installing the product	9
4.1 Location	9
4.2 Mechanical installation	10
4.3 Frost protection	14
4.4 Electrical connection	15
5. Starting up the product	17
5.1 Flushing the pipe system	17
5.2 Priming	17
5.3 Checking the direction of rotation	18
5.4 Starting up the pump	18
5.5 Shaft seal run-in	18
5.6 Frequency of starts and stops	18
6. Handling and storing the product	18
6.1 Storing the product	18
7. Servicing the product	19
7.1 Contaminated products	19
7.2 Adjusting the shaft	19
7.3 Blanking flanges	20
7.4 Maintaining the product	20
8. Fault finding the product	21
9. Technical data	23
9.1 Operating conditions	23
9.2 Enclosure class	23
9.3 Electrical data	23
9.4 Sound pressure level	23
9.5 Environment	24
10. Disposing of the product	24

1. General information



Read this document before you install the product. Installation and operation must comply with local regulations and accepted codes of good practice.

1.1 Hazard statements

The symbols and hazard statements below may appear in Grundfos installation and operating instructions, safety instructions and service instructions.



DANGER

Indicates a hazardous situation which, if not avoided, will result in death or serious personal injury.



WARNING

Indicates a hazardous situation which, if not avoided, could result in death or serious personal injury.



CAUTION

Indicates a hazardous situation which, if not avoided, could result in minor or moderate personal injury.

The hazard statements are structured in the following way:



SIGNAL WORD

Description of the hazard

Consequence of ignoring the warning

- Action to avoid the hazard.

1.2 Notes

The symbols and notes below may appear in Grundfos installation and operating instructions, safety instructions and service instructions.



Observe these instructions for explosion-proof products.



A blue or grey circle with a white graphical symbol indicates that an action must be taken.



A red or grey circle with a diagonal bar, possibly with a black graphical symbol, indicates that an action must not be taken or must be stopped.



If these instructions are not observed, it may result in malfunction or damage to the equipment.



Tips and advice that make the work easier.

2. Product introduction

2.1 Product description

These instructions apply to the pump types TP and TPD fitted with Grundfos motors or Siemens motors. If the pump is fitted with another motor make, please note that the motor data may differ from the data stated in these instructions.

2.2 Identification

2.2.1 Nameplate

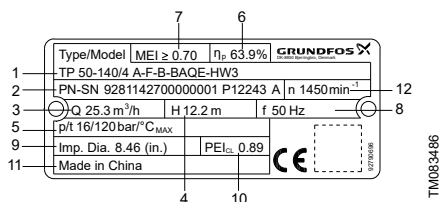

TM083486

Example of TP Nameplate

Pos.	Description
1	Type designation
2	Identification code
	92811427 Product number
	00000001 Serial number
	P1 Production site code
	2243 Production year and week (YYWW)
	A Service model
3	Nominal flow rate
4	Nominal pump head
5	Pressure rating and maximum temperature
6	Hydraulic efficiency at best efficiency point
7	Minimum efficiency index
8	Frequency
9	Actual impeller diameter
	WRAS approval or Pump Energy Index (PEI)
10	PEI _{CL} : constant load
	PEI _{VL} : variable load
11	Country of origin
12	Rated pump speed

2.2.2 Type key

Example of type key: TPED 65-120/2 S-A-F-A-BQQE-GDB

Pos.	1	2	3	4	5	6	7	8	9	10	11	12	13	14
Code	TP	E	D	65	-120	/2	S	-A	-F	-A	-BQQE	-G	D	B

Pos.	Description
1	Pump range
2	Electronically speed-controlled pump, Series 1000, 2000
3	Twin-head pump
4	Nominal diameter of inlet and outlet ports, DN
5	Maximum head [dm]
6	Pole number
7	Code for pump version. The codes may be combined: [Blank]: TPE Series 1000 with MGE motor and without sensor S: TPE Series 2000 with factory-fitted differential-pressure sensor NC: TPE Series 1000 with Siemens motor with integrated CUE SC: TPE Series 2000 with built-in differential-pressure sensor and Siemens motor with integrated CUE
8	Code for pump version. The codes may be combined: A: Basic version A3: PN 25 flange B: Oversize motor (+E): With ATEX approval, certificate or test report, the second character of the code for pump version is an E I: PN 6 flange X: Special version
9	Code for pipe connection: F: DIN flange O: Union
10	Code for materials: A: Basic version I: Stainless steel 1.4308 pump housing and motor stool Z: Bronze pump housing and motor stool B: Bronze impeller S: Stainless steel 1.4408 impeller O: Ductile cast-iron pump housing with cast-iron impeller Y: Ductile cast-iron pump housing with bronze impeller Q: Ductile cast-iron pump housing with stainless steel 1.4408 impeller
11	Code for shaft seal including other plastic and rubber pump parts, except the neck ring. See Codes for shaft seal.
12	Code for rated motor power [kW]. See Codes for rated motor power.
13	Code for phase and voltage or other information [V]. See Codes for phase and voltage or other information.
14	Code for speed variant [rpm]. See Codes for speed variant.

2.2.2.1 Codes for shaft seal

Code example	Description	Code explanation
B	Shaft seal type	A: O-ring seal with fixed seal driver
		B: Rubber bellows seal
		D: O-ring seal, balanced
		G: Bellows seal with reduced seal faces
		R: O-ring seal with reduced seal faces
Q	Material of rotating face	A: Carbon, antimony-impregnated
		B: Carbon, resin-impregnated
		Q: Silicon carbide
Q	Material of stationary seal	B: Carbon, resin-impregnated
		Q: Silicon carbide
		U: Tungsten carbide
E	Material of secondary seal	E: EPDM
		P: NBR rubber
		V: FKM
		F: FXM

2.2.2.2 Codes for rated motor power

Pos. 12 in TP, TPD type key example.

Code	Description	
	[hp]	[kW]
A	0.16	0.12
B	0.25	0.18
C	0.33	0.25
D	0.5	0.37
E	0.75	0.55
F	1	0.75
G	1.5	1.1
H	2	1.5
I	3	2.2
J	4	3
K	5 (5.5 ¹⁾)	3.7 (4 ¹⁾)
L	7.5	5.5
M	10	7.5
N	15	11

Code	Description	
	[hp]	[kW]
O	20	15
P	25	18.5
Q	30	22
R	40	30
S	50	37
T	60	45
U	75	55
V	100	75
W	125	90
X	Bare shaft pump	
Y	> 200 ²⁾	> 150 ²⁾
1	150	110
2	175	132
3	200	150
4	215 ³⁾	160 ³⁾
5	250 ³⁾	185 ³⁾

1) Value in bracket is for the standard IEC motor size. Value outside bracket is for the motor size according to NEMA standards.

2) Used for pumps where the pump shaft input power exceeds 200 hp (150 kW) and is not regulated under the DOE pump rule.

3) Special cases with power sizes above 200 hp (150 kW) which are still regulated under the DOE pump rule. For example: Pump has a P2 value of 198 hp (147.6 kW) in its duty point (in DOE scope) but customer wants the 215 hp (160 kW) motor instead of the 200 hp (150 kW). The pump is in scope of the DOE regulation and requires a PEI value and a motor code.

2.2.2.3 Codes for phase and voltage or other information

Pos. 13 in TP, TPD type key example.

Code	Description
A	E-motor (ECM ⁴⁾), 1 x 200-240 V
B	E-motor (ECM ⁴⁾), 3 x 200-240 V
C	E-motor (ECM ⁴⁾), 3 x 440-480 V
D	E-motor (ECM ⁴⁾), 3 x 380-500 V
W	Not for sale in North America
X	No motor or US DOE regulated motor (CC marked motor)
Y	Out of DOE scope
Z	E-motor, asynchronous motor

4) ECM: Electronically Commutated Motor.

2.2.2.4 Codes for speed variant

Pos. 14 in TP, TPD type key example.

Code	Description
A	1450-2200 RPM, E-motor (ECM ⁵⁾)
B	2900-4000 RPM, E-motor (ECM ⁵⁾)
C	4000-5900 RPM, E-motor (ECM ⁵⁾)
1	2-pole, 50 Hz (Asynchronous motor)
2	2-pole, 60 Hz (Asynchronous motor)
3	4-pole, 50 Hz (Asynchronous motor)
4	4-pole, 60 Hz (Asynchronous motor)
5	6-pole, 50 Hz (Asynchronous motor)
6	6-pole, 60 Hz (Asynchronous motor)
7	8-pole, 50 Hz (Asynchronous motor)
8	8-pole, 60 Hz (Asynchronous motor)

5) ECM: Electronically Commutated Motor.

2.3 Applications

The pumps are designed to circulate hot or cold water in residential, institutional and industrial applications in systems, such as:

- heating systems
- district heating plants
- central heating systems for blocks of flats
- air-conditioning systems
- cooling systems.

In addition, the pump range is used for liquid transfer and water supply in systems such as:

- washing systems
- hot water recirculation systems
- industrial systems in general.

To ensure optimum operation, the dimensioning range of the system must fall within the performance range of the pump.

2.3.1 Pumped liquids

TP, TPD pumps are suitable for thin, clean, non-aggressive and non-explosive liquids without solid particles or fibres that may attack the pump mechanically or chemically.

Examples:

- Central heating system water (the water must meet the requirements of accepted standards on water quality in heating systems)
- cooling liquids
- hot tap water
- industrial liquids
- softened water.

The pumping of liquids with a density and/or kinematic viscosity higher than that of water will have the following effects:

- a considerable pressure drop
- a drop in hydraulic performance
- a rise in power consumption.

In such cases, the pump must be fitted with a bigger motor. If in doubt, contact Grundfos.

The EPDM O-rings fitted as standard are primarily suitable for water.

If the water contains mineral/synthetic oils or chemicals or if other liquids than water are pumped, the O-rings must be chosen accordingly.

3. Receiving the product

3.1 Delivery

The pump is delivered from the factory in a carton with a wooden bottom, which is specially designed for transport by fork-lift truck or a similar vehicle.

4. Installing the product



CAUTION

Hot or cold surface

Minor or moderate personal injury



- When pumping hot or cold liquids, make sure that persons cannot accidentally come into contact with hot or cold surfaces.

4.1 Location

The pump must be sited in a dry, well-ventilated, but frost-free position.

When installing pumps with oval bolt holes in the pump flange (PN 6/10), use washers as shown in the figure below.

- 1: Washer
- 2: Installation side
- 3: Pump side

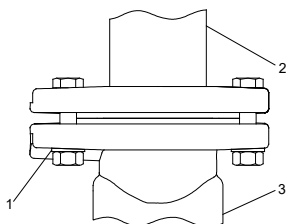

Use of washers for oval bolt holes

Arrows on the pump housing show the direction of flow of liquid through the pump.

Pumps with motors smaller than 11 kW can be installed in horizontal or vertical pipes.

Pumps with motors of 11 kW and up may only be installed in horizontal pipes with the motor in vertical position.

However, some TP, TPE pumps of 11 kW and up may be suspended directly in the pipes (horizontally or vertically). See the section TP, TPE pumps from 11 kW and up suspended in the pipes.

In installations where the pump is suspended directly in the pipes, the pump can support the pipe length L on both sides of the pump (L less than $3 \times DN$), see the figure below. In installations where the pump is suspended directly in the pipes, the pump must be

lifted and held in correct position by means of ropes or similar until both pump flanges are completely fastened to the pipe flanges.

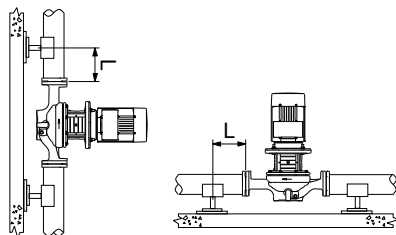

Pump suspended directly in the pipes



The motor must never be installed below the horizontal plane.

For inspection and motor or pump head removal, the following clearance is required above the motor:

- 300 mm for motors up to and including 4.0 kW.
- 1 m for motors of 5.5 kW and up.

See the figure below.

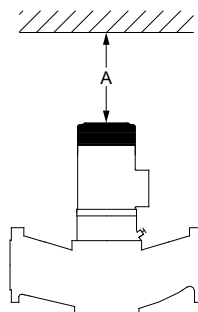

Required clearance above the motor

Motor size	A
0.25 - 4.0 kW	≥ 300 mm
5.5 kW and up	≥ 1 m

Twin-head pumps installed in horizontal pipes must be fitted with an automatic vent in the upper part of the pump housing. See the figure below. The automatic vent is not supplied with the pump.

TM085150

TM010683

TM003733

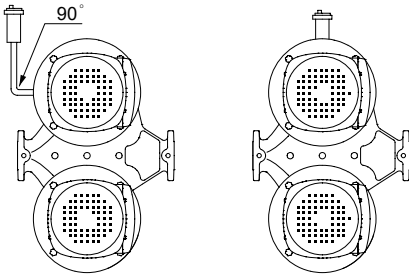

TM0038127

Automatic vent

If the liquid temperature falls below the ambient temperature or if the pump is installed outside, condensation may form in the motor during inactivity. In this case, make sure that the drain hole in the motor flange is open and points downwards. See the figure below.

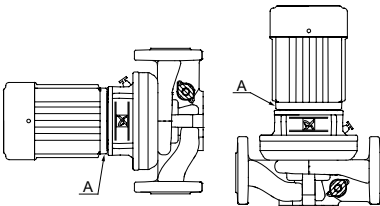

TM009831

A: Drain hole Drain hole in motor flange

If twin-head pumps are used for pumping liquids with a temperature below 0 °C (32 °F), condensed water may freeze and cause the coupling to get stuck. The problem can be remedied by installing heating elements. For pumps with motors smaller than 11 kW, the pump must be installed with the motor shaft in horizontal position.

4.2 Mechanical installation



The pump must be installed according to national water regulations and standards.

4.2.1 Lifting the product

DANGER **Overhead load**

Death or serious personal injury

- The lifting eyes fitted to large pump motors can be used for lifting the pump head (motor, motor stool and impeller). Do not use the lifting eyes for lifting the entire pump and motor assembly.
- TPD: Do not use the centrally positioned thread of the pump housing for lifting purposes as the thread is placed below the centre of gravity of the pump.



Pumps without lifting eyes must be lifted by means of nylon straps.

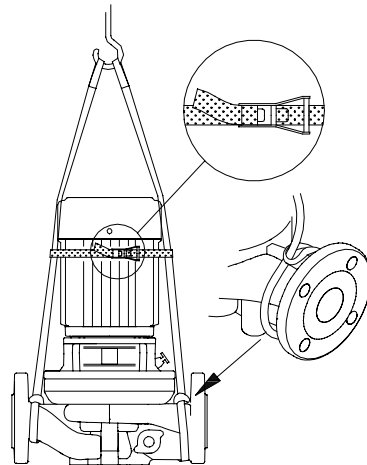

TM027007

TP pump without lifting eyes

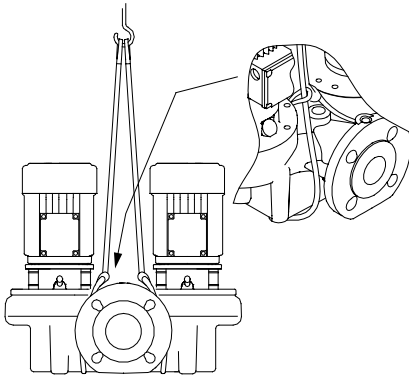

TPD pumps without lifting eyes

Pumps with lifting eyes must be lifted by means of nylon straps and shackles.

TM027008

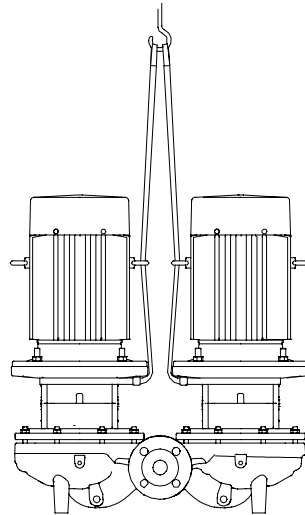

TPD pump with lifting eyes

TM027010

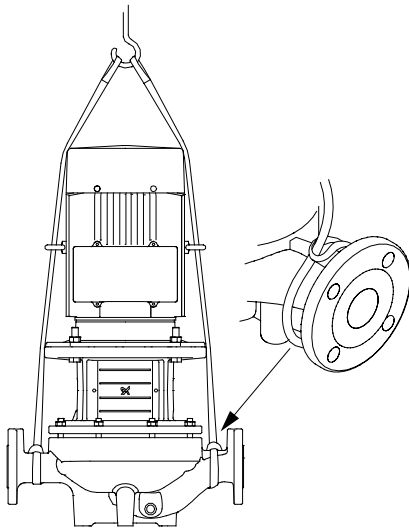

TP pump with lifting eyes

TM027009

4.2.2 Pipes

Fit isolating valves on either side of the pump to avoid draining the system if the pump needs to be cleaned or repaired.

The pump is suitable for pipeline mounting, provided that the pipes are adequately supported either side of the pump. TP 25-50, 25-80, 25-90, 32-50, 32-80, 32-90, 40-50, 40-80 and 40-90 are designed for pipeline mounting only.

When installing the pipes, make sure that the pump housing is not stressed by the pipes.

The inlet and outlet pipes must be of an adequate size, taking the pump inlet pressure into account.

To avoid sediment buildup, do not fit the pump at the lowest point of the system.

Install the pipes so that air pockets are avoided, especially on the inlet side of the pump. See the figure below.

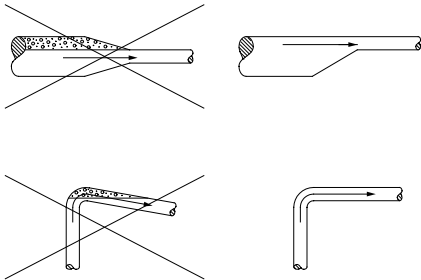

TM002263

Correct pipes on the inlet side of the pump

DANGER

Pump can explode

Death or serious personal injury



- The pump is not allowed to run against a closed valve except during startup. Operating against a closed valve at an extended period of time will cause an increase in temperature and the formation of steam and may result in damages to or explosion of the pump housing. The valve must be kept open during operation.

If there is any danger of the pump running against a closed outlet valve, ensure a minimum liquid flow through the pump by connecting a bypass or a drain to the outlet pipe. The drain can for instance be connected to a tank. The minimum flow rate must be at least 10 % of the maximum flow rate. The flow rate and head are stated on the pump nameplate.

4.2.3 Elimination of noise and vibrations

In order to achieve optimum operation and minimum noise and vibration, consider vibration damping of the pump. Generally, always consider this for pumps with motors of 11 kW and up. Vibration damping is mandatory for motors of 90 kW and up as well as the pumps stated in the table below:

Pump type	P2 [kW]	Frequency [Hz]
TP 200-280/4	37	60
TP 200-290/4	37	50
TP 200-320/4	45	60
TP 200-360/4	55	60
TP 200-390/4	75	60

Smaller motor sizes, however, may also cause undesirable noise and vibration.

Noise and vibration are generated by the revolutions of the motor and pump and by the flow in pipes and fittings. The effect on the environment is subjective and depends on correct installation and the state of the rest of the system.

Elimination of noise and vibrations is best achieved by means of a concrete foundation, vibration dampers and expansion joints. See the figure below.

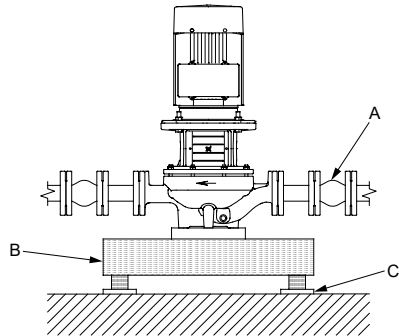

TM024953

Foundation for TP pump

Pos.	Description
A	Expansion joint
B	Concrete pedestal
C	Vibration damper

At high liquid velocities (greater than 5 m/s), we recommend that you fit larger expansion joints matching the pipes.

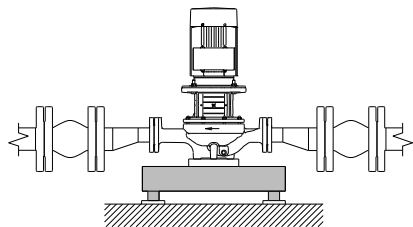

TM085205

TP pump installed with larger expansion joints

4.2.4 Foundation

We recommend that you install the pump on a concrete foundation which is heavy enough to provide permanent and rigid support for the entire pump. The foundation must be capable of absorbing any vibration, normal strain or shock. As a rule of thumb, the weight of the concrete foundation must be 1.5 times the weight of the pump. Place the pump on the foundation and fasten it.

4.2.4.1 Recommended concrete foundations for TP, TPD Series 300 pumps

For TP Series 300 pumps with weights of 150 kg or more, we recommend that you mount the pump on a concrete foundation with the dimensions stated in the table below. The same recommendation applies for TPD Series 300 pumps with weights of 300 kg or more.

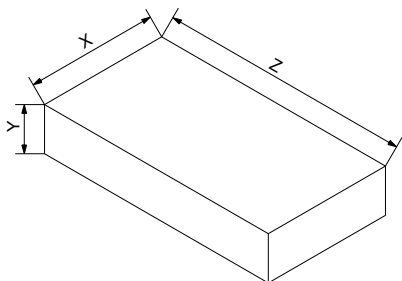

TM039190

Foundation for TP, TPD Series 300 pumps

Concrete foundation dimensions			
Pump weight [kg]	Y (height) [mm]	Z (length) [mm]	X (width) [mm]
150	280	565	565
200	310	620	620
250	330	670	670
300	360	710	710
350	375	750	750
400	390	780	780
450 ≤ DN 200	410	810	810
500	420	840	840
550	440	870	870
600	450	900	900
650	460	920	920
700	470	940	940
750	480	970	970

Concrete foundation dimensions			
Pump weight [kg]	Y (height) [mm]	Z (length) [mm]	X (width) [mm]
800	490	990	990
850	500	1010	1010
900	510	1030	1030
950	520	1050	1050
1000	530	1060	1060
1050	540	1080	1080
1100	550	1100	1100
1150	560	1100	1100
1200	560	1130	1130
1250	570	1150	1150
1300	580	1160	1160
1350	590	1180	1180
1400	600	1190	1190
1450	600	1200	1200
1500	610	1220	1220
1550	620	1230	1230
1600	620	1250	1250
1650	630	1250	1250
1700	635	1270	1270
800	450	1400	800
1000	450	1400	1000
1200	450	1400	1200
1400	500	1600	1200
1600	500	1600	1350
1800	500	1600	1500
2000	550	1600	1600
2200 DN 300	550	1700	1700
2400 DN 350	550	1800	1800
2600 DN 400	600	1800	1800
3000	600	2000	2000
3400	680	2000	2000
3800	760	2000	2000
4200	840	2000	2000
4600	920	2000	2000
5000	1000	2000	2000
5400	1080	2000	2000

4.2.5 Changing terminal box positions



DANGER **Electric shock**

Death or serious personal injury

- Before starting work on the pump, make sure that the power supply has been switched off and that it cannot be accidentally switched on.

The terminal box can be turned to four positions, in 90 ° steps.

Change the terminal box position as follows:

1. If necessary, remove the coupling guards using a screwdriver. Do not remove the coupling.
2. Remove the screws securing the motor to the pump.
3. Turn the motor to the required position.
4. Replace and tighten the screws.
5. Replace the coupling guards.

4.2.6 Base plate

Single-head pumps (except TP 25-50, 25-80, 25-90, 32-50, 32-80, 32-90, 40-50, 40-80 and 40-90) have two tapped holes in the bottom of the pump housing which can be used for fitting a Grundfos base plate to the pump. The base plate is available as an optional extra.

Twin-head pumps have four tapped holes in the bottom of the pump housing. For some twin-head pumps, a base plate consisting of two halves is available.

4.2.7 Insulation



Do not insulate the motor stool as this will trap any vapour escaping from the shaft seal, thus causing corrosion. Covering the motor stool with insulation will also make inspection and service difficult.

Follow the guidelines in the figure below when insulating the pump.

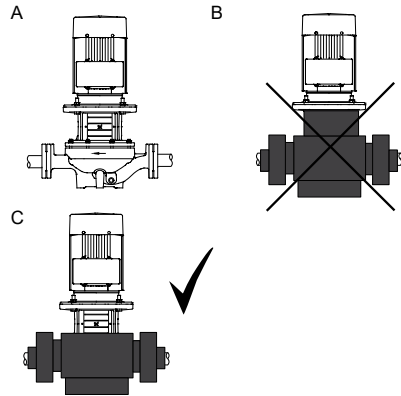

Insulation of TP pumps

Pos.	Description
A	Without insulation
B	Incorrect insulation
C	Correct insulation

4.3 Frost protection

Pumps which are not being used during periods of frost must be drained to avoid damage.

4.3.1 Condensation cover

When installing the pumps outdoors, provide the motor with a suitable cover to avoid condensation, and make sure that the drain hole in the motor flange is open and points downwards. See the figure below.

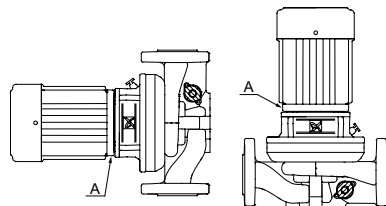

A: Drain hole
Drain hole in motor flange

When mounting the condensation cover on top of the motor, make sure to leave enough space for the air to cool the motor.

TM052328

TM009631

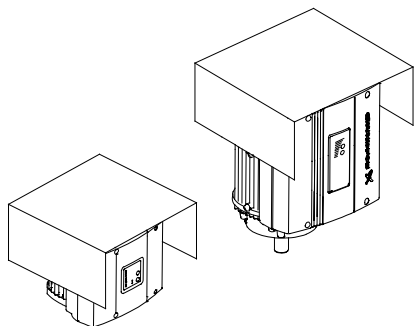

TM028514

Motors with condensation cover

4.4 Electrical connection

Make the electrical connection in accordance with local regulations.

DANGER Electric shock

Death or serious personal injury

- Before removing the terminal box cover and before removing or dismantling the pump, make sure that the power supply has been switched off. Connect the pump to an external main switch with a minimum contact gap of 3 mm in all poles.
- The pump must be connected to an external main switch close to the pump and to a motor-protective circuit breaker. Make sure you can lock the main switch in OFF position (isolated). Type and requirements are specified in EN 60204-1, 5.3.2.



DANGER Electric shock

Death or serious personal injury

- The motor must be protected against overload by an external motor-protective circuit breaker with IEC trip class 10 or 20.
- We recommend that you use trip class 20.
- The current setting of the motor-protective circuit breaker must be adjusted to the nominal current stated on the motor nameplate.



The operating voltage and frequency are stated on the pump nameplate. Make sure that the motor is suitable for the power supply on which it will be used. Single-phase standard motors incorporate a thermal switch and require no additional motor protection.

Three-phase motors must be connected to a motor protection device.

Motors of 3 kW and up incorporate thermistors (PTC). The thermistors are designed according to DIN 44082.

Make the electrical connection as shown in the diagram inside the terminal box cover.

The motors of twin-head pumps are to be connected separately.

4.4.1 Cable entry/screwed connection, MG motor

All motors are supplied without screwed cable entries. The table below shows the numbers and sizes of cable entry holes of the terminal box of Grundfos MG motors according to the standard EN 50262.

Frame size	Model	Number x dimensions	Description
MG 71 and 80	B, C	2 x M20 x 1.5	The holes have precast threads and are closed with knock-out cable entries.
MG 90 and 100	B, C, D	4 x M20	The holes are closed with knock-out cable entries.
MG 112 and 132	C, D, F, H	4 x M25	
MG 160 and 180	F, H	4 x M40 2 x M20	

4.4.2 Frequency converter operation



Motor types Siemens, MG 71 and MG 80 for supply voltages up to and including 440 V (seeing the motor nameplate) must be protected against voltage peaks higher than 650 V between the supply terminals.

4.4.2.1 Grundfos motors

All three-phase Grundfos motors from frame size 90 and up can be connected to a frequency converter.

The connection of a frequency converter will often have the effect that the motor insulation system is loaded more and that the motor will be more noisy than during normal operation. In addition, large motors are more at risk of being loaded with bearing currents caused by the frequency converter.

Check these operating conditions if the pump is driven via a frequency converter:

Operating conditions	Action
2-pole motors from 45 kW, 4-pole motors from 37 kW and 6-pole motors from 30 kW	Check that one of the motor bearings is electrically isolated. Contact Grundfos.
Noise critical applications	Fit an output filter between the motor and the frequency converter; this reduces the voltage peaks and thus the noise.
Particularly noise critical applications	Fit a sinusoidal filter.
Cable length	Fit a cable that meets the specifications laid down by the frequency converter supplier. The length of the cable between motor and frequency converter affects the motor load.
Supply voltage up to 500 V	Check that the motor is suitable for frequency converter operation.
Supply voltage between 500 V and 690 V	Fit a sinusoidal filter between the motor and the frequency converter which reduces the voltage peaks and thus the noise, or check that the motor has reinforced insulation.
Supply voltage of 690 V and higher	Fit a sinusoidal filter and check that the motor has reinforced insulation.



Grundfos MG motors do not have reinforced insulation. When it comes to reinforced insulation, other motors supplies are able to supply such motors as FPV variants.

4.4.2.2 Other motor makes than Grundfos

Contact Grundfos or the motor manufacturer.

4.4.3 Synchronous motors

Pumps fitted with synchronous motors must be connected to a Grundfos CUE frequency converter.



Example of installation without filter

Symbol	Designation
1	CUE
4	Standard motor
One line	Unscreened cable
Double line	Screened cable



Synchronous motors must not be connected directly to mains supply.

The CUE must be of T/C CUE203 followed by additional numbers and characters. See the CUE Installation and operating instruction to setup frequency driver together with synchronous motor. If another frequency driver brand other than CUE is required or specified, contact Grundfos.

T/C: CUE203P1M2T5E20H1BXCXXXXXXAXBXCXXXXX
 Prod. no: 12345678 S/N: 123456G234
 1.5 kW (400V)
 IN: 3x380-500 V 50/60Hz 3.7A
 OUT: 3x0-Vin 0-100Hz 4.1 A 2.8 kVA
 CHASSIS/IP20 Tamb. 45C/122F
 ■■■■■■■■BAR CODE■■■■■■■■■

CE
MADE IN DENMARK

Listed 76X1 E134261 Ind. Contr. Eq.
See manual for prefuse

CAUTION:
SEE MANUAL / VOIR MANUEL

WARNING:
STORED CHARGE DO NOT TOUCH UNTIL
4 MIN AFTER DISCONNECTION
CHARGE RESIDUELLE, ATTENDRE
4 MIN APRES DECONNEXION

Example of CUE nameplate

Text	Description
T/C	CUE: product name 203... :internal code

5. Starting up the product

5.1 Flushing the pipe system

CAUTION

Biological hazard

Minor or moderate personal injury



- When pumping drinking water, the pump must be flushed thoroughly with clean water before startup in order to remove any foreign matters, such as preservatives, test liquid, or grease.

- Before starting up the pump, thoroughly clean, flush and fill the pipe system with clean water.



The warranty does not cover any damage caused by flushing the pipe system by means of the pump.



The pump is not designed to pump liquids containing solid particles such as pipe debris and welding slag.

5.2 Priming



Always fill and vent the pump before starting the pump. To ensure correct venting, the vent screw must point upwards.

5.2.1 Priming the product in closed systems or open systems where the liquid level is above the pump inlet

WARNING

Escaping liquid

Death or serious personal injury



- Pay attention to the orientation of the vent hole to ensure that the escaping liquid does not cause personal injury or damage to the motor or other components.
- In hot-liquid installations, pay special attention to the risk of personal injury caused by scalding hot liquid.
- In cold-liquid installations, pay special attention to the risk of personal injury caused by cold liquid.

1. Close the isolating valve on the outlet side and loosen the vent screw in the motor stool.

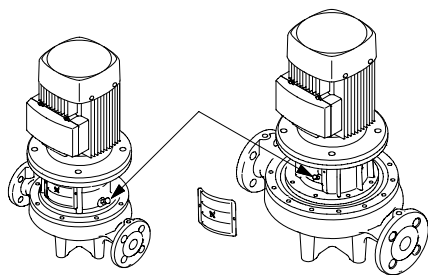

TMO38126

Position of vent screw

2. Slowly open the isolating valve on the inlet side until a steady stream of liquid runs out of the vent hole.
3. Tighten the vent screw and completely open the isolating valve(s).

5.2.2 Priming the product in open systems where the liquid level is below the pump inlet

The inlet pipe and the pump must be filled with liquid and vented before the pump is started.

1. Close the isolating valve on the outlet side and open the isolating valve on the inlet side.
2. Loosen the vent screw.
3. Remove the plug from one of the pump flanges, depending on the pump location.
4. Pour liquid through the priming hole until the inlet pipe and the pump are filled with liquid.
5. Replace the plug and tighten securely.
6. Tighten the vent screw.

The inlet pipe can to some extent be filled with liquid and vented before it is connected to the pump. A priming device can also be installed before the pump.

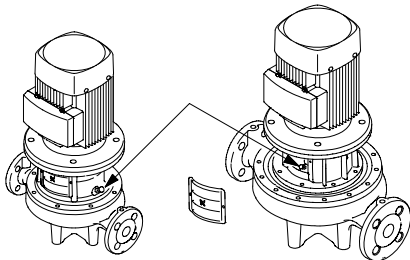

TMO38126

Position of vent screw

5.3 Checking the direction of rotation

Do not start the pump to check the direction of rotation until it has been filled with liquid.



Do not check the direction of rotation with the motor alone, as an adjustment of the shaft position is required when the coupling has been removed.

The correct direction of rotation is shown by arrows on the motor fan cover or on the pump housing.

5.4 Starting up the pump

WARNING

Escaping liquid

Death or serious personal injury

- Pay attention to the orientation of the vent hole to ensure that the escaping liquid does not cause personal injury or damage to the motor or other components.
- In hot-liquid installations, pay special attention to the risk of personal injury caused by scalding hot liquid.
- In cold-liquid installations, pay special attention to the risk of personal injury caused by cold liquid.



1. Open the isolating valve on the inlet side of the pump completely and leave the isolating valve on the outlet side almost closed.
2. Start the pump.
3. Vent the pump during startup by loosening the air vent screw in the pump head or pump head cover until a steady stream of liquid runs out of the vent hole
4. When the pipe system has been filled with liquid, slowly open the isolating valve on the outlet side until it is completely open.

5.5 Shaft seal run-in

The seal faces are lubricated by the pumped liquid, meaning that there may be a certain amount of leakage from the shaft seal. When the pump is started for the first time, or when a new shaft seal has been installed, a certain run-in period is required before the leakage is reduced to an acceptable level. The time required for this depends on the operating conditions, that is every time the operating conditions change, a new run-in period will be started.

Under normal conditions, the leaking liquid will evaporate. As a result, no leakage will be detected. Liquids such as kerosene will not evaporate, and drops will be visible, but this is not a shaft seal failure.

5.6 Frequency of starts and stops

Frame size	Maximum number of starts per hour		
	2-pole	4-pole	6-pole
56-71	100	250	350
80-100	60	140	160
112-132	30	60	80
160-180	15	30	50
200-225	8	15	30
250-315	4	8	12

- On twin-head pumps, the duty and standby pumps must be alternated on a regular basis, that is once a week, to ensure an even distribution of the operating hours on both pumps. Pump change can be effected either manually or automatically by installing a suitable pump controller.
- If twin-head pumps are used for hot water recirculation, the duty and standby pumps must be alternated on a regular basis, that is once a day, to avoid blocking of the standby pump due to deposits (calcareous deposits, etc.). We recommend automatic pump change.

6. Handling and storing the product

6.1 Storing the product

The contractor must inspect the equipment on delivery and make sure that it is stored in such a way that corrosion and damage are avoided.

If you do not operate the pump soon after arrival, store it in a clean, dry place with slow, moderate changes in ambient temperature. Protect the pump from moisture, dust, dirt and foreign bodies. Before and during storage we recommend these precautions:

1. Make sure that the bearings are filled with the recommended grease to prevent moisture from entering around the shaft.
2. Make sure that the inlet and outlet ports and all other openings are covered with cardboard, wood or masking tape to prevent foreign objects from entering the pump.
3. Cover the unit with a tarpaulin or waterproof material or other suitable covering if it is to be stored where there is no protective covering.
4. Rotate the shaft two turns every two weeks to prevent corrosion of the bearing surfaces and the shaft seal faces due to moisture.

If more than six months will pass before the equipment is put into operation, consider applying a suitable corrosion inhibitor to the internal pump parts.

Make sure that the corrosion inhibitor used does not affect the rubber parts with which it comes into contact.

Commercially available preservatives can be used for this purpose. Please observe the manufacturer's instructions for application or removal.

To prevent water, dust, etc. from entering the pump, keep all openings covered until the pipes are to be fitted. The cost of having to dismantle the pump during startup to remove foreign objects can be very high.

7. Servicing the product

7.1 Contaminated products



CAUTION

Biological hazard

Minor or moderate personal injury

- Flush the pump thoroughly with clean water and rinse the pump parts in water after dismantling.

The product will be classified as contaminated if it has been used for a liquid which is toxic or injurious to health.

If you request Grundfos to service the product, contact Grundfos with details about the liquid before returning the product for service. Otherwise, Grundfos can refuse to accept the product for service.

The product must be cleaned thoroughly before you return it.

Costs of returning the product are to be paid by the customer.

7.2 Adjusting the shaft

If the motor has been removed during installation or for repair of the pump, the pump shaft must be adjusted after the motor has been replaced.

7.2.1 Adjusting the shaft for pumps with two-part coupling, TP Series 100 and 200

Make sure that the shaft pin is fitted in the pump shaft.

Adjust the pump shaft as follows:

1. Remove the coupling guards using a screwdriver.
2. Fit the hexagon socket head screws in the coupling and leave loose.
3. Raise the coupling and the pump shaft as far as possible (towards the motor) with a screwdriver or a similar tool so that the pump and motor shafts touch each other.

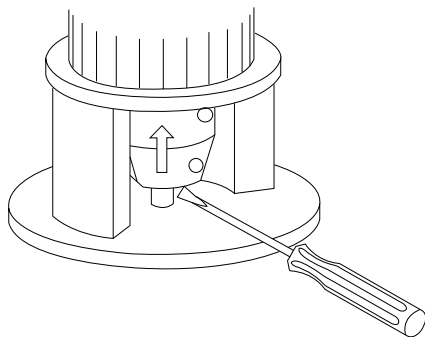

TM006415

Raising the coupling and the pump shaft

4. Tighten the hexagon socket head screws in the coupling to 5 Nm (0.5 kpm).
5. Check that the gaps either side of the coupling halves are equal.
6. Tighten the screws two and two (one side at a time) to the torque stated below.

Hexagon socket head screw	Torque
M6 x 20	13 Nm (1.3 kpm)
M8 x 25	31 Nm (3.1 kpm)

7. Fit the coupling guards.

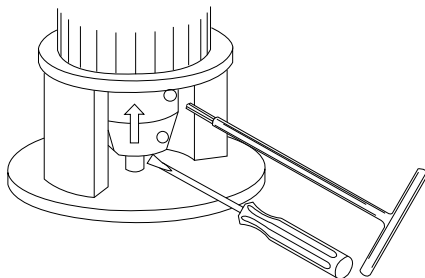

TM006416

Tightening the screws

7.2.2 Pumps with integral shaft and coupling

For pumps with integral shaft and coupling, we recommend that you do not remove the motor. If the motor has been removed, it is necessary to remove the motor stool in order to refit the motor correctly. Otherwise, the shaft seal may be damaged.

7.3 Blanking flanges

For twin-head pumps, a blanking flange with a pump housing gasket is available. See the figure below.

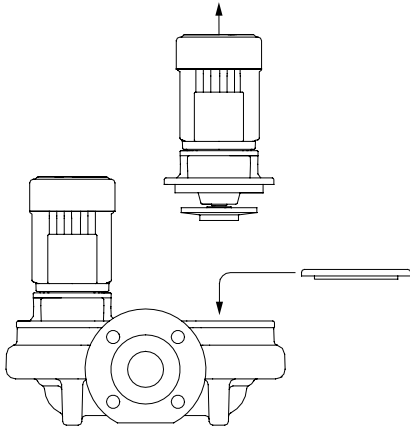

Fitting the blanking flange

If one pump requires service, the blanking flange is fitted to allow the other pump to continue operating.

7.4 Maintaining the product

DANGER Electric shock

Death or serious personal injury



- Before starting any work on the product, make sure that the power supply has been switched off and that it cannot be accidentally switched on.

WARNING Escaping liquid

Death or serious personal injury



- Make sure that the escaping liquid does not cause injury to persons or damage to the motor or other components. In hot-liquid installations, pay special attention to the risk of injury caused by scalding hot liquid. In cold-liquid installations, pay special attention to the risk of injury caused by the cold liquid.

7.4.1 Pump

The pump is maintenance-free.

If the pump is to be drained for a long period of inactivity, inject a few drops of silicone oil on the shaft between the motor stool and the coupling. This will prevent the shaft seal faces from sticking.

TP 25-50/2, 25-80/2, 25-90/2, 32-50/2, 32-80/2, 32-90/2, 40-50/2, 40-80/2 and 40-90/2 must be operated minimum once every month in minimum 5 minutes to prevent the shaft seal faces from sticking.

7.4.2 Motor

The motor must be checked at regular intervals. It is important to keep the motor clean in order to ensure adequate ventilation. If the pump is installed in a dusty environment, both pump and motor must be cleaned and checked regularly.

7.4.3 Lubrication

MG motors

The bearings of motors up to 11 kW are greased for life and require no lubrication.

The bearings of motors of 11 kW and up must be greased in accordance with the indications on the motor nameplate.

Other motors

For other motor makes with grease nipples, lubricate the motor according to the indications on the motor nameplate.

7.4.4 Bearing grease

The motor must be lubricated with a lithium-based, high-temperature grease.

- The technical specification of the grease must correspond to DIN 51825, K3N, or better.
- The viscosity of the basic oil must be higher than 50 cSt (mm²/s) at 40 °C (104 °F) and 8 cSt (mm²/s) at 100 °C (212 °F).
- The grease filling rate must be 30-40 %.

7.4.5 Frost protection

Pumps which are not being used during periods of frost must be drained to avoid damage.

TMD06360

8. Fault finding the product

DANGER

Electric shock

Death or serious personal injury



- Before removing the terminal box cover and before removing or dismantling the pump, make sure that the power supply has been switched off and that it cannot be accidentally switched on.



WARNING

Escaping liquid

Death or serious personal injury

- Make sure that the escaping liquid does not cause injury to persons or damage to the motor or other components.
- In hot-liquid installations, pay special attention to the risk of injury caused by scalding hot liquid.
- In cold-liquid installations, pay special attention to the risk of injury caused by the cold liquid.

Fault	Cause and remedy
The motor does not run when started.	Power supply failure. The fuses are blown. The motor protection device has tripped. The main contacts in the motor protection device are not making contact or the coil is faulty. The control circuit fuses are defective. The motor is defective.
The motor protection device trips immediately when the power supply is switched on.	Power supply failure. The contacts in the motor protection device are faulty. The cable connection is loose or faulty. The motor winding is defective. The pump is mechanically blocked. The overload setting is too low.
The motor protection device trips occasionally.	The overload setting is too low. The supply voltage is periodically too low or too high. The differential pressure across the pump is too low.
The motor protection device has not tripped, but the pump does not run.	Power supply failure. The fuses are blown. The main contacts in the motor protection device are not making contact or the coil is faulty. The control circuit fuses are defective.
The pump capacity is not constant.	The pump inlet pressure is too low. The inlet pipe or pump is partly blocked by impurities. The pump draws in air.
The pump runs but gives no water.	The inlet pipe or pump is blocked by impurities. The foot or non-return valve is blocked in closed position. There is a leakage in the inlet pipe. There is air in the inlet pipe or pump. The motor rotates in the wrong direction.
The pump runs backwards when switched off. ⁶⁾	There is a leakage in the inlet pipe. The foot or non-return valve is defective. The foot or non-return valve is blocked in open or partly open position.

Fault	Cause and remedy
There is a leakage in the shaft seal.	<p>The pump shaft position is incorrect.</p> <p>The shaft seal is defective.</p>
Noise.	<p>The pump is cavitating.</p> <p>The pump does not rotate freely (frictional resistance) because of incorrect pump shaft position.</p> <p>Frequency converter operation: See section Frequency converter operation.</p> <p>There is resonance in the installation.</p> <p>There are foreign bodies in the pump.</p>
The pump runs constantly (applies only to pumps with automatic start/stop).	<p>The stop pressure is too high in relation to the required quantity of water.</p> <p>The water consumption is larger than anticipated.</p> <p>There is a leakage in the outlet pipe.</p> <p>The direction of rotation of the pump is incorrect.</p> <p>The pipes, valves or strainer are blocked by impurities.</p> <p>The pump controller, if used, is defective.</p>
The period of operation is too long (applies only to pumps with automatic start/stop).	<p>The stop pressure is too high in relation to the required quantity of water.</p> <p>The pipes, valves or strainer are blocked by impurities.</p> <p>The pump is partly blocked or seized up.</p> <p>The water consumption is larger than anticipated.</p> <p>There is a leakage in the outlet pipe.</p>

⁶⁾ In twin-head pump installations, the standby pump will often rotate slowly.

9. Technical data

9.1 Operating conditions

9.1.1 Ambient temperature



Do not exceed the allowable maximum ambient temperature stated on the motor nameplate. If nothing is stated, the allowable maximum ambient temperature is 40 °C.

Maximum ambient temperature: 55 °C (131 °F).

9.1.2 Liquid temperature

Liquid temperature: -40 to +150 °C (-40 to +302 °F).

The maximum liquid temperature depends on the mechanical shaft seal type and the pump type.

Depending on the cast-iron version and the pump application, the maximum liquid temperature may be limited by local regulations and laws.

The maximum liquid temperature is marked on the pump nameplate.



If the pump is operating with liquids at high temperatures, the life of the shaft seal may be reduced. It may be necessary to replace the shaft seal more often.

9.1.3 Maximum Operating pressure and test pressure



Do not exceed the maximum operating pressure stated on the pump nameplate.

The pressure test has been made with water containing anticorrosive additives at a temperature of 20 °C (68 °F).

Pressure stage	Operating pressure		Test pressure	
	[bar]	[MPa]	[bar]	[MPa]
PN 6	6	0.6	10	1.0
PN 6 / PN 10	10	1.0	15	1.5
PN 16	16	1.6	24	2.4
PN 25	25	2.5	38	3.8

The pumps comply with IEC 60335-2-51 if they are used in closed heating or cooling systems.

The pumps comply with IEC 60335-2-51 if they are used in service water applications and the maximum allowable operating pressure stated on the pump nameplate is equal to or higher than 1.0 MPa.

9.1.4 Inlet pressure

To ensure optimum and quiet pump operation, the inlet pressure (system pressure) must be adjusted correctly.

For the calculation of specific inlet pressures, contact the local Grundfos company or see the data booklet for TP, TPD, TPE, TPED, TPE2, TPE2 D, TPE3, TPE3 D, if at hand.

The total pressure of the inlet pressure and the pump pressure must be lower than the maximum operating pressure stated on the pump nameplate.

The pumps comply with IEC 60335-2-51 if the maximum inlet pressure is equal to or less than half of the maximum operating pressure stated on the pump nameplate.

9.1.5 Max. flow rate



Do not exceed the maximum flow rate as otherwise there is a risk of, for instance, cavitation and overload.

The minimum and maximum flow rates and total heads can be read either from the performance curve pages in the relevant data booklets or from a curve for a specific pump when selecting it in Grundfos Product Center. See www.grundfos.com.

9.2 Enclosure class

Closed drain hole in motor: IP55

Open drain hole in motor: IP44. See the figure below.

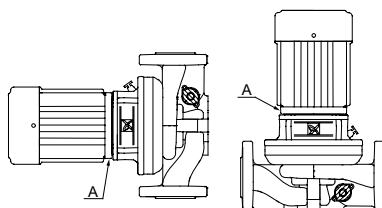

Drain hole (A) in motor flange

TM008631

9.3 Electrical data

See the motor nameplate.

9.4 Sound pressure level

The sound pressure level of the pump with single-phase motors is lower than 70 dB(A).

The sound pressure level of the pump with three-phase motors is shown in the table below.

Maximum sound pressure level

Three-phase motors [kW]	50 Hz [dB(A)]			60 Hz [dB(A)]	
	2-pole	4-pole	6-pole	2-pole	4-pole
0.12	< 70	< 70	-	< 70	< 70
0.18	< 70	< 70	-	< 70	< 70
0.25	56	41	-	< 70	45
0.37	56	45	-	57	45
0.55	57	42	-	56	45
0.75	53	59.5	-	57	49
1.1	53	49.5	-	58	53
1.5	58	50	47	64	53
2.2	60	51	52	65	55
3.0	59.5	53	63	53.5	55
4.0	63	54	63	67.5	57
5.5	62	50	63	68	62
7.5	60	51	66	65	62
11.0	60	53	-	64.5	66
15.0	60	66	-	65	66
18.5	60.5	63	-	65.5	63
22.0	65.5	63	-	70.5	63
30.0	70	65	-	75	65
37.0	71	66	-	75	65
45.0	67	66	-	75	65
55.0	72	67	-	75	68
75.0	74	70	-	77	71
90.0	73	70	-	77	71
110	76	70	-	81	75
132	76	70	-	81	75
160	76	70	-	81	75
200	-	70	-	81	75
250	-	73	-	86	77
315	-	73	-	-	77
355	-	75	-	-	-
400	-	75	-	-	-
500	-	75	-	-	-
560	-	78	-	-	-
630	-	78	-	-	-

9.5 Environment

The pump is designed for installation in a non-aggressive and non-explosive atmosphere.

Maximum relative humidity: 95 %.

10. Disposing of the product

This product or parts of it must be disposed of in an environmentally sound way.

1. Use the public or private waste collection service.
2. If this is not possible, contact the nearest Grundfos company or service workshop.



The crossed-out wheeled bin symbol on a product means that it must be disposed of separately from household waste. When a product marked with this symbol reaches its end of life, take it to a collection point designated by the local waste disposal authorities. The separate collection and recycling of such products will help protect the environment and human health.

See also end-of-life information at www.grundfos.com/product-recycling.

Appendix A

A.1. Minimum inlet pressure, 50 Hz, 2-pole

Pump type (50 Hz)	p [bar]						
	20 °C	60 °C	90 °C	110 °C	120 °C	140 °C	150 °C
TP 25-50/2	0.1	0.1	0.2	0.5	-	-	-
TP 25-80/2	0.1	0.1	0.1	0.3	-	-	-
TP 25-90/2	0.1	0.1	0.2	0.5	-	-	-
TP 32-50/2	0.1	0.1	0.1	0.2	-	-	-
TP 32-80/2	0.1	0.1	0.2	0.5	-	-	-
TP 32-90/2	0.1	0.1	0.2	0.5	-	-	-
TP, TPD 32-60/2	0.1	0.1	0.2	1.0	1.5	3.2	-
TP, TPD 32-120/2	0.1	0.2	0.7	1.5	2.0	3.7	-
TP, TPD 32-150/2	0.1	0.3	0.8	1.6	2.1	3.8	-
TP, TPD 32-180/2	0.5	0.7	1.2	2.0	2.5	4.2	-
TP, TPD 32-230/2	0.7	0.9	1.4	2.2	2.7	4.4	-
TP, TPD 32-200/2	0.1	0.1	0.2	0.9	1.5	3.1	-
TP, TPD 32-250/2	0.1	0.1	0.3	1.0	1.6	3.2	-
TP, TPD 32-320/2	0.1	0.1	0.6	1.3	1.9	3.5	-
TP, TPD 32-380/2	0.1	0.2	0.7	1.4	2.0	3.6	-
TP, TPD 32-460/2	0.1	0.2	0.7	1.4	1.9	3.6	-
TP, TPD 32-580/2	0.2	0.4	0.9	1.6	2.2	3.8	-
TP 40-50/2	0.1	0.1	0.1	0.3	-	-	-
TP 40-80/2	0.1	0.1	0.2	0.5	-	-	-
TP 40-90/2	0.1	0.1	0.2	0.5	-	-	-
TP, TPD 40-60/2	0.1	0.1	0.5	1.2	1.8	3.5	-
TP, TPD 40-120/2	0.1	0.1	0.4	1.2	1.7	3.4	-
TP 40-180/2	0.1	0.2	0.7	1.5	2.0	3.7	-
TP, TPD 40-190/2	0.1	0.3	0.8	1.6	2.1	3.8	-
TP, TPD 40-230/2	0.7	0.9	1.4	2.2	2.7	4.4	-
TP, TPD 40-270/2	0.7	0.9	1.4	2.2	2.7	4.4	-
TP, TPD 40-240/2	0.1	0.1	0.4	1.1	1.7	3.3	-
TP, TPD 40-300/2	0.1	0.1	0.4	1.1	1.6	3.3	-
TP, TPD 40-360/2	0.2	0.4	0.9	1.6	2.1	3.8	-
TP, TPD 40-430/2	0.1	0.1	0.5	1.2	1.8	3.4	-
TP, TPD 40-530/2	0.1	0.1	0.6	1.3	1.9	3.5	-
TP, TPD 40-630/2	0.1	0.3	0.8	1.5	2.1	3.7	-
TP, TPD 50-60/2	0.1	0.1	0.4	1.1	1.7	3.4	-
TP, TPD 50-120/2	0.1	0.2	0.7	1.5	2.0	3.7	-

Pump type (50 Hz)	p [bar]						
	20 °C	60 °C	90 °C	110 °C	120 °C	140 °C	150 °C
TP, TPD 50-180/2	0.1	0.2	0.7	1.4	2.0	3.7	-
TP, TPD 50-160/2	0.1	0.1	0.1	0.8	1.4	3.0	-
TP, TPD 50-190/2	0.1	0.1	0.1	0.8	1.4	3.0	-
TP, TPD 50-240/2	0.1	0.1	0.1	0.8	1.4	3.0	-
TP, TPD 50-290/2	0.1	0.1	0.2	0.9	1.5	3.1	-
TP, TPD 50-360/2	0.1	0.1	0.2	1.0	1.5	3.1	-
TP, TPD 50-430/2	0.1	0.1	0.4	1.1	1.6	3.3	-
TP, TPD 50-420/2	0.1	0.1	0.3	1.1	1.6	3.2	-
TP, TPD 50-540/2	0.1	0.1	0.5	1.3	1.8	3.4	-
TP, TPD 50-630/2	0.1	0.1	0.6	1.4	1.9	3.6	-
TP, TPD 50-710/2	0.6	0.8	1.3	2.0	2.6	4.2	-
TP, TPD 50-830/2	0.5	0.7	1.2	2.0	2.5	4.1	-
TP, TPD 50-900/2	1.0	1.2	1.7	2.4	3.0	4.6	-
TP, TPD 65-60/2	0.1	0.3	0.8	1.5	2.1	3.8	-
TP, TPD 65-120/2	0.5	0.7	1.2	2.0	2.5	4.2	-
TP, TPD 65-180/2	0.3	0.5	1.0	1.8	2.3	4.0	-
TP, TPD 65-170/2	0.1	0.1	0.1	0.9	1.4	3.1	-
TP, TPD 65-210/2	0.1	0.1	0.2	0.9	1.5	3.1	-
TP, TPD 65-250/2	0.1	0.1	0.3	1.0	1.6	3.2	-
TP, TPD 65-340/2	0.1	0.1	0.2	0.9	1.4	3.1	-
TP, TPD 65-410/2	0.1	0.1	0.2	0.9	1.4	3.1	-
TP, TPD 65-460/2	0.1	0.1	0.2	1.0	1.5	3.1	-
TP, TPD 65-550/2	0.1	0.1	0.3	1.0	1.6	3.2	-
TP, TPD 65-660/2	0.1	0.1	0.4	1.1	1.6	3.3	-
TP, TPD 65-720/2	0.1	0.1	0.6	1.3	1.9	3.5	-
TP, TPD 65-930/2	0.6	0.8	1.3	2.0	2.6	4.2	-
TP, TPD 80-120/2	1.2	1.4	1.9	2.7	3.2	4.9	-
TP, TPD 80-140/2	0.1	0.2	0.7	1.4	1.9	3.6	-
TP, TPD 80-180/2	0.1	0.1	0.3	1.1	1.6	3.2	-
TP, TPD 80-210/2	0.1	0.1	0.4	1.1	1.7	3.3	-
TP, TPD 80-240/2	0.1	0.1	0.5	1.3	1.8	3.4	-
TP, TPD 80-250/2	0.1	0.3	0.8	1.6	2.1	3.7	-
TP, TPD 80-330/2	0.1	0.2	0.7	1.4	2.0	3.6	-
TP, TPD 80-400/2	0.2	0.4	0.9	1.6	2.2	3.8	-
TP, TPD 80-520/2	0.1	0.1	0.6	1.4	1.9	3.5	-
TP, TPD 80-570/2	0.1	0.3	0.8	1.6	2.1	3.7	-
TP, TPD 80-700/2	0.6	0.8	1.3	2.1	2.6	4.2	-
TP, TPD 100-120/2	1.9	2.1	2.6	3.4	3.9	5.6	-

Pump type (50 Hz)	p [bar]						
	20 °C	60 °C	90 °C	110 °C	120 °C	140 °C	150 °C
TP, TPD 100-160/2	0.1	0.1	0.6	1.3	1.9	3.5	-
TP, TPD 100-200/2	0.1	0.1	0.4	1.2	1.7	3.3	-
TP, TPD 100-240/2	0.1	0.1	0.5	1.3	1.8	3.4	-
TP, TPD 100-250/2	0.6	0.8	1.3	2.0	2.5	4.2	-
TP, TPD 100-310/2	0.6	0.8	1.3	2.0	2.6	4.2	-
TP, TPD 100-360/2	0.6	0.8	1.3	2.0	2.5	4.2	-
TP, TPD 100-390/2	1.0	1.2	1.7	2.4	3.0	4.6	-
TP, TPD 100-480/2	1.5	1.7	2.2	2.9	3.5	5.1	-
TP 100-530/2	1.6	1.8	2.2	3.2	3.7	5.3	6.6
TP 100-650/2	1.4	1.6	2.0	3.0	3.5	5.1	6.4
TP 100-800/2	1.3	1.5	1.9	2.9	3.4	5.0	6.3
TP 100-950/2	1.3	1.5	1.9	2.9	3.4	5.0	6.3
TP 100-1040/2	1.2	1.4	1.8	2.8	3.3	4.9	6.2
TP 100-1200/2	1.2	1.4	1.8	2.8	3.3	4.9	6.2
TP 100-1410/2	1.2	1.4	1.8	2.8	3.3	4.9	6.2
TP 125-310/2	0.4	0.5	1.0	1.7	2.3	3.9	-
TP 125-360/2	0.5	0.6	1.1	1.8	2.4	4.0	-

A.2. Minimum inlet pressure, 50 Hz, 4-pole

Pump type (50 Hz)	p [bar]						
	20 °C	60 °C	90 °C	110 °C	120 °C	140 °C	150 °C
TP, TPD 32-30/4	0.1	0.1	0.1	0.8	1.4	3.1	-
TP, TPD 32-40/4	0.1	0.1	0.1	0.9	1.4	3.1	-
TP, TPD 32-60/4	0.1	0.1	0.3	1.1	1.6	3.3	-
TP, TPD 32-80/4	0.1	0.1	0.1	0.5	1.0	2.7	-
TP, TPD 32-100/4	0.1	0.1	0.1	0.5	1.1	2.7	-
TP, TPD 32-120/4	0.1	0.1	0.1	0.6	1.1	2.7	-
TP, TPD 40-30/4	0.1	0.1	0.2	0.9	1.5	3.2	-
TP 40-60/4	0.1	0.1	0.1	0.8	1.4	3.1	-
TP, TPD 40-90/4	0.1	0.1	0.3	1.0	1.6	3.3	-
TP, TPD 40-100/4	0.1	0.1	0.2	0.9	1.5	3.1	-
TP, TPD 40-110/4	0.1	0.1	0.1	0.6	1.2	2.8	-
TP, TPD 40-140/4	0.1	0.1	0.1	0.7	1.3	2.9	-
TP, TPD 50-30/4	0.1	0.1	0.1	0.9	1.4	3.1	-
TP, TPD 50-60/4	0.1	0.1	0.2	0.9	1.5	3.2	-
TP, TPD 50-90/4	0.1	0.1	0.1	0.6	1.1	2.8	-
TP, TPD 50-80/4	0.1	0.1	0.1	0.8	1.3	3.0	-

Pump type (50 Hz)	p [bar]						
	20 °C	60 °C	90 °C	110 °C	120 °C	140 °C	150 °C
TP, TPD 50-120/4	0.1	0.1	0.1	0.7	1.3	2.9	-
TP, TPD 50-140/4	0.1	0.1	0.1	0.7	1.3	2.9	-
TP, TPD 50-190/4	0.1	0.1	0.1	0.9	1.4	3.0	-
TP, TPD 50-230/4	0.1	0.1	0.2	1.0	1.5	3.1	-
TP, TPD 65-30/4	0.1	0.2	0.7	1.5	2.0	3.7	-
TP, TPD 65-60/4	0.2	0.4	0.9	1.6	2.2	3.9	-
TP, TPD 65-90/4	0.1	0.1	0.1	0.6	1.1	2.7	-
TP, TPD 65-110/4	0.1	0.1	0.1	0.6	1.1	2.7	-
TP, TPD 65-130/4	0.1	0.1	0.1	0.6	1.1	2.8	-
TP, TPD 65-150/4	0.1	0.1	0.1	0.6	1.2	2.8	-
TP, TPD 65-170/4	0.1	0.1	0.1	0.6	1.2	2.8	-
TP, TPD 65-240/4	0.1	0.1	0.1	0.8	1.3	2.9	-
TP, TPD 80-30/4	0.8	1.0	1.5	2.2	2.8	4.5	-
TP, TPD 80-60/4	0.8	1.0	1.5	2.3	2.8	4.5	-
TP, TPD 80-70/4	0.1	0.1	0.1	0.8	1.3	2.9	-
TP, TPD 80-90/4	0.1	0.1	0.1	0.7	1.2	2.8	-
TP, TPD 80-110/4	0.1	0.1	0.1	0.8	1.4	3.0	-
TP, TPD 80-150/4	0.1	0.1	0.1	0.8	1.3	2.9	-
TP, TPD 80-170/4	0.1	0.1	0.2	1.0	1.5	3.1	-
TP, TPD 80-240/4	0.1	0.1	0.3	1.0	1.5	3.2	-
TP, TPD 80-270/4	0.1	0.1	0.2	0.9	1.5	3.1	-
TP, TPD 80-340/4	0.1	0.1	0.3	1.1	1.6	3.2	-
TP, TPD 100-30/4	0.8	1.0	1.5	2.2	2.8	4.5	-
TP, TPD 100-65/4	0.1	0.1	0.1	0.8	1.3	3.0	-
TP, TPD 100-70/4	0.1	0.1	0.1	0.8	1.3	3.0	-
TP, TPD 100-90/4	0.1	0.1	0.1	0.9	1.4	3.0	-
TP, TPD 100-110/4	0.1	0.1	0.2	1.0	1.5	3.1	-
TP, TPD 100-130/4	0.1	0.1	0.6	1.3	1.9	3.5	-
TP, TPD 100-170/4	0.3	0.5	1.0	1.7	2.3	3.9	-
TP 100-140/4	0.2	0.4	0.8	1.8	2.3	3.9	5.2
TP, TPD 100-200/4	0.1	0.1	0.5	1.2	1.8	3.4	4.7
TP, TPD 100-250/4	0.1	0.2	0.7	1.4	2.0	3.6	4.9
TP, TPD 100-330/4	0.3	0.5	1.0	1.7	2.3	3.9	5.2
TP, TPD 100-370/4	0.3	0.5	1.0	1.7	2.3	3.9	5.2
TP, TPD 100-410/4	0.5	0.7	1.2	1.9	2.5	4.1	5.4
TP 125-60/4	0.1	0.1	0.1	0.8	1.4	3.0	-
TP 125-80/4	0.1	0.1	0.1	0.9	1.4	3.1	-
TP 125-95/4	0.1	0.1	0.2	0.9	1.5	3.1	-

Pump type (50 Hz)	p [bar]						
	20 °C	60 °C	90 °C	110 °C	120 °C	140 °C	150 °C
TP, TPD 125-110/4	0.1	0.1	0.1	0.9	1.4	3.0	-
TP, TPD 125-130/4	0.1	0.1	0.2	0.9	1.5	3.1	-
TP, TPD 125-160/4	0.1	0.1	0.2	1.0	1.5	3.1	-
TP 125-150/4	0.2	0.4	0.8	1.8	2.3	3.9	5.2
TP, TPD 125-190/4	0.1	0.1	0.2	0.9	1.5	3.1	4.4
TP, TPD 125-230/4	0.1	0.1	0.3	1.0	1.6	3.2	4.5
TP, TPD 125-300/4	0.1	0.1	0.2	0.9	1.5	3.1	4.4
TP, TPD 125-340/4	0.1	0.1	0.3	1.0	1.5	3.2	4.5
TP, TPD 125-400/4	0.1	0.1	0.3	1.0	1.6	3.2	4.5
TP 150-70/4	0.1	0.1	0.3	1.1	1.6	3.2	-
TP 150-110/4	0.1	0.1	0.4	1.1	1.7	3.3	-
TP 150-155/4	0.1	0.1	0.5	1.2	1.8	3.4	-
TP 150-170/4	0.1	0.1	0.6	1.3	1.9	3.5	-
TP, TPD 150-130/4	0.1	0.1	0.4	1.1	1.6	3.3	4.6
TP, TPD 150-160/4	0.1	0.1	0.4	1.1	1.7	3.3	4.6
TP, TPD 150-200/4	0.1	0.1	0.4	1.1	1.7	3.3	4.6
TP, TPD 150-220/4	0.1	0.1	0.5	1.2	1.8	3.4	4.7
TP, TPD 150-250/4	0.1	0.1	0.6	1.3	1.9	3.5	4.8
TP 150-260/4	0.1	0.1	0.5	1.2	1.8	3.4	4.7
TP 150-280/4	0.1	0.3	0.8	1.5	2.1	3.7	5.0
TP 150-340/4	0.1	0.2	0.7	1.5	2.0	3.6	4.9
TP 150-390/4	0.1	0.2	0.7	1.4	2.0	3.6	4.9
TP 150-450/4	0.1	0.1	0.5	1.2	1.8	3.4	4.7
TP 150-520/4	0.1	0.1	1.0	1.5	1.9	3.5	4.8
TP 150-660/4	0.1	0.2	0.7	1.4	1.9	3.6	4.9
TP 150-680/4	0.1	0.2	0.7	1.4	2.0	3.6	-
TP 200-50/4	0.3	0.4	0.9	1.7	2.2	3.8	-
TP 200-70/4	0.1	0.3	0.8	1.5	2.1	3.7	-
TP 200-90/4	0.1	0.2	0.7	1.4	2.0	3.6	-
TP 200-130/4	0.1	0.1	0.5	1.2	1.8	3.4	-
TP 200-150/4	0.1	0.1	0.4	1.2	1.7	3.3	-
TP 200-160/4	0.3	0.5	1.0	1.7	2.3	3.9	5.2
TP 200-190/4	0.2	0.4	0.9	1.6	2.2	3.8	5.1
TP 200-200/4	0.2	0.4	0.9	1.6	2.1	3.8	5.1
TP 200-240/4	0.1	0.2	0.7	1.4	2.0	3.6	4.9
TP 200-270/4	0.1	0.1	0.4	1.1	1.7	3.3	4.6
TP 200-290/4	0.1	0.1	0.6	1.3	1.9	3.5	4.8
TP 200-320/4	0.1	0.1	0.5	1.2	1.8	3.4	4.7

Pump type (50 Hz)	p [bar]						
	20 °C	60 °C	90 °C	110 °C	120 °C	140 °C	150 °C
TP 200-330/4	0.1	0.1	0.3	1.1	1.6	3.2	4.5
TP 200-360/4	0.1	0.1	0.3	1.1	1.6	3.2	4.5
TP 200-400/4	0.1	0.1	0.3	1.0	1.6	3.2	4.5
TP 200-410/4	0.1	0.2	0.7	1.4	1.9	3.6	4.9
TP 200-470/4	0.1	0.1	0.4	1.1	1.6	3.3	4.6
TP 200-530/4	0.1	0.1	0.4	1.1	1.7	3.3	4.6
TP 200-590/4	0.1	0.2	0.7	1.4	2.0	3.6	4.9
TP 200-660/4	0.2	0.4	0.9	1.7	2.2	3.8	5.1
TP 300-190/4	0.5	0.7	1.1	2.1	2.6	4.2	5.5
TP 300-220/4	0.3	0.5	0.9	1.9	2.4	4.0	5.3
TP 300-250/4	0.1	0.3	0.7	1.7	2.2	3.8	5.1
TP 300-290/4	0.5	0.7	1.1	2.1	2.6	4.2	5.5
TP 300-390/4	0.5	0.7	1.1	2.1	2.6	4.2	5.5
TP 300-420/4	0.5	0.7	1.1	2.1	2.6	4.2	5.5
TP 300-430/4	0.5	0.7	1.1	2.1	2.6	4.2	5.5
TP 300-500/4	0.4	0.6	1.0	2.0	2.5	4.1	5.4
TP 300-550/4	0.3	0.5	0.9	1.9	2.4	4.0	5.3
TP 350-280/4	1.7	1.9	2.3	3.3	3.8	5.4	6.7
TP 350-320/4	1.6	1.8	2.2	3.2	3.7	5.3	6.6
TP 350-360/4	1.5	1.7	2.1	3.1	3.6	5.2	6.5
TP 350-420/4	1.4	1.6	2.0	3.0	3.5	5.1	6.4
TP 350-480/4	1.3	1.5	1.9	2.9	3.4	5.0	6.3
TP 350-530/4	0.5	0.7	1.1	2.1	2.6	4.2	5.5
TP 350-650/4	0.4	0.6	1.0	2.0	2.5	4.1	5.4
TP 350-780/4	0.3	0.5	0.9	1.9	2.4	4.0	5.3
TP 400-470/4	0.7	0.7	1.4	2.1	2.6	4.3	5.6
TP 400-510/4	1.6	1.7	2.3	3.1	3.6	5.2	6.5
TP 400-540/4	0.8	0.9	1.5	2.2	2.8	4.4	5.7
TP 400-670/4	0.8	0.8	1.5	2.2	2.8	4.4	5.7
TP 400-720/4	0.9	0.9	1.5	2.3	2.8	4.5	5.8
TP 400-760/4	1.4	1.5	2.1	2.8	3.4	5.0	6.3
TP 400-670/4	0.8	0.8	1.5	2.2	2.8	4.4	5.7
TP 400-720/4	0.9	0.9	1.5	2.3	2.8	4.5	5.8
TP 400-760/4	1.4	1.5	2.1	2.8	3.4	5.0	6.3

A.3. Minimum inlet pressure, 50 Hz, 6-pole

Pump type (50 Hz)	p [bar]						
	20 °C	60 °C	90 °C	110 °C	120 °C	140 °C	150 °C
TP, TPD 125-60/6	0.1	0.1	0.1	0.7	1.2	2.8	-
TP, TPD 125-70/6	0.1	0.1	0.1	0.7	1.3	2.9	-
TP, TPD 125-80/6	0.1	0.1	0.1	0.7	1.2	2.9	-
TP, TPD 125-100/6	0.1	0.1	0.1	0.8	1.4	3.0	-
TP, TPD 125-130/6	0.1	0.1	0.1	0.7	1.3	2.9	-
TP, TPD 125-160/6	0.1	0.1	0.1	0.7	1.3	2.9	-
TP, TPD 150-60/6	0.1	0.1	0.1	0.7	1.3	2.9	-
TP, TPD 150-70/6	0.1	0.1	0.1	0.7	1.3	2.9	-
TP, TPD 150-90/6	0.1	0.1	0.1	0.8	1.3	2.9	-
TP, TPD 150-110/6	0.1	0.1	0.1	0.8	1.3	3.0	-

A.4. Minimum inlet pressure, 60 Hz, 2-pole

Pump type (60 Hz)	p [bar]						
	20 °C	60 °C	90 °C	110 °C	120 °C	140 °C	150 °C
TP 32-80/2	0.4	0.4	0.4	1.2	1.7	3.4	-
TP 32-160/2	0.4	0.6	1.1	1.9	2.4	4.1	-
TP 32-220/2	0.7	0.9	1.4	2.2	2.7	4.4	-
TP 32-260/2	0.7	0.9	1.4	2.2	2.7	4.4	-
TP 32-330/2	0.7	0.9	1.4	2.2	2.7	4.4	-
TP, TPD 32-300/2	0.1	0.1	0.1	0.7	1.2	2.8	-
TP, TPD 32-360/2	0.1	0.1	0.1	0.7	1.2	2.8	-
TP, TPD 32-450/2	0.1	0.1	0.1	0.7	1.2	2.8	-
TP, TPD 32-550/2	0.1	0.1	0.1	0.7	1.2	2.9	-
TP, TPD 32-680/2	0.1	0.1	0.2	0.9	1.5	3.1	-
TP, TPD 32-820/2	0.5	0.7	1.2	1.9	2.5	4.1	-
TP 40-80/2	0.1	0.3	0.8	1.6	2.1	3.8	-
TP 40-160/2	0.1	0.2	0.7	1.5	2.0	3.7	-
TP 40-240/2	0.4	0.6	1.1	1.9	2.4	4.1	-
TP 40-270/2	0.7	0.9	1.4	2.2	2.7	4.4	-
TP 40-330/2	0.7	0.9	1.4	2.2	2.7	4.4	-
TP 40-390/2	0.7	0.9	1.4	2.2	2.7	4.4	-
TP, TPD 40-400/2	0.1	0.1	0.1	0.9	1.4	3.1	-
TP, TPD 40-460/2	0.1	0.1	0.3	1.0	1.6	3.2	-
TP, TPD 40-530/2	0.1	0.1	0.4	1.1	1.7	3.3	-
TP, TPD 40-690/2	0.1	0.2	0.7	1.4	2.0	3.6	-

Pump type (60 Hz)	p [bar]						
	20 °C	60 °C	90 °C	110 °C	120 °C	140 °C	150 °C
TP, TPD 40-820/2	0.1	0.3	0.8	1.6	2.1	3.7	-
TP, TPD 40-920/2	0.4	0.6	1.1	1.8	2.4	4.0	-
TP 50-80/2	0.1	0.1	0.6	1.4	1.9	3.6	-
TP 50-160/2	0.4	0.6	1.1	1.9	2.4	4.1	-
TP 50-240/2	0.3	0.5	1.0	1.8	2.3	4.0	-
TP, TPD 50-250/2	0.1	0.1	0.2	1.0	1.5	3.1	-
TP, TPD 50-300/2	0.1	0.1	0.3	1.0	1.6	3.2	-
TP, TPD 50-350/2	0.1	0.1	0.3	1.0	1.6	3.2	-
TP, TPD 50-410/2	0.1	0.1	0.4	1.1	1.6	3.3	-
TP, TPD 50-430/2	0.1	0.1	0.4	1.1	1.7	3.3	-
TP, TPD 50-530/2	0.1	0.1	0.5	1.3	1.8	3.5	-
TP, TPD 50-640/2	0.1	0.1	0.6	1.4	1.9	3.5	-
TP, TPD 50-720/2	0.1	0.3	0.8	1.6	2.1	3.7	-
TP, TPD 50-790/2	0.5	0.7	1.2	1.9	2.5	4.1	-
TP, TPD 50-880/2	0.8	1.0	1.5	2.2	2.8	4.4	-
TP 50-1050/2	1.1	1.3	1.8	2.5	3.1	4.7	-
TP 65-80/2	0.6	0.8	1.3	2.1	2.6	4.3	-
TP 65-160/2	1.1	1.3	1.8	2.6	3.1	4.8	-
TP 65-240/2	0.9	1.1	1.6	2.4	2.9	4.6	-
TP, TPD 65-200/2	0.1	0.1	0.3	1.0	1.5	3.2	-
TP, TPD 65-250/2	0.1	0.1	0.4	1.1	1.7	3.3	-
TP, TPD 65-340/2	0.1	0.1	0.2	1.0	1.5	3.1	-
TP, TPD 65-390/2	0.1	0.1	0.3	1.0	1.5	3.2	-
TP, TPD 65-480/2	0.1	0.1	0.3	1.0	1.6	3.2	-
TP, TPD 65-540/2	0.1	0.1	0.3	1.1	1.6	3.2	-
TP, TPD 65-630/2	0.1	0.1	0.4	1.1	1.7	3.3	-
TP, TPD 65-740/2	0.1	0.1	0.6	1.3	1.9	3.5	-
TP, TPD 65-910/2	0.1	0.2	0.7	1.5	2.0	3.6	-
TP, TPD 65-920/2	0.1	0.2	0.7	1.4	2.0	3.6	-
TP, TPD 65-1050/2	0.1	0.2	0.7	1.5	2.0	3.6	-
TP 80-160/2	2.1	2.3	2.8	3.6	4.1	5.8	-
TP, TPD 80-200/2	0.5	0.7	1.2	1.9	2.5	4.1	-
TP, TPD 80-240/2	0.1	0.2	0.7	1.4	2.0	3.6	-
TP, TPD 80-290/2	0.1	0.3	0.8	1.5	2.1	3.7	-
TP, TPD 80-330/2	0.2	0.4	0.9	1.7	2.2	3.8	-
TP, TPD 80-400/2	0.6	0.8	1.3	2.1	2.6	4.2	-
TP, TPD 80-480/2	0.1	0.3	0.8	1.5	2.1	3.7	-
TP, TPD 80-530/2	0.2	0.4	0.9	1.6	2.1	3.8	-

Pump type (60 Hz)	p [bar]						
	20 °C	60 °C	90 °C	110 °C	120 °C	140 °C	150 °C
TP, TPD 80-640/2	0.6	0.8	1.3	2.0	2.6	4.2	-
TP, TPD 80-750/2	0.6	0.8	1.3	2.0	2.6	4.2	-
TP, TPD 100-230/2	0.4	0.6	1.1	1.9	2.4	4.0	-
TP, TPD 100-300/2	0.2	0.4	0.9	1.6	2.2	3.8	-
TP, TPD 100-370/2	0.3	0.5	1.0	1.7	2.3	3.9	-
TP, TPD 100-350/2	0.9	1.1	1.6	2.3	2.9	4.5	-
TP, TPD 100-380/2	1.2	1.4	1.9	2.6	3.2	4.8	-
TP, TPD 100-530/2	1.7	1.9	2.4	3.2	3.7	5.3	-
TP, TPD 100-630/2	1.4	1.6	2.1	2.8	3.3	5.0	-
TP, TPD 100-700/2	3.0	3.2	3.7	4.4	5.0	6.6	-
TP 100-760/2	1.7	1.9	2.3	3.3	3.8	5.4	6.7
TP 100-940/2	1.6	1.8	2.2	3.2	3.7	5.3	6.6
TP 100-1040/2	1.6	1.8	2.2	3.2	3.7	5.3	6.6
TP 100-1200/2	1.9	2.1	2.5	3.5	4.0	5.6	6.9
TP 100-1360/2	1.8	2.0	2.4	3.4	3.9	5.5	6.8
TP 100-1510/2	1.8	2.0	2.4	3.4	3.9	5.5	6.8

A.5. Minimum inlet pressure, 60 Hz, 4-pole









Pump type (60 Hz)	p [bar]						
	20 °C	60 °C	90 °C	110 °C	120 °C	140 °C	150 °C
TP 32-40/4	0.1	0.1	0.1	0.9	1.4	3.1	-
TP 32-80/4	0.1	0.1	0.5	1.3	1.8	3.5	-
TP, TPD 32-120/4	0.1	0.1	0.1	0.7	1.3	2.9	-
TP, TPD 32-140/4	0.1	0.1	0.1	0.7	1.3	2.9	-
TP, TPD 32-190/4	0.1	0.1	0.1	0.8	1.4	3.0	-
TP 40-40/4	0.1	0.1	0.3	1.1	1.6	3.3	-
TP 40-80/4	0.1	0.1	0.2	1.0	1.5	3.2	-
TP, TPD 40-110/4	0.1	0.1	0.1	0.6	1.2	2.8	-
TP, TPD 40-150/4	0.1	0.1	0.1	0.7	1.3	2.9	-
TP, TPD 40-180/4	0.1	0.1	0.1	0.7	1.3	2.9	-
TP, TPD 40-230/4	0.1	0.1	0.1	0.8	1.3	3.0	-
TP 50-40/4	0.1	0.1	0.3	1.1	1.6	3.3	-
TP 50-80/4	0.1	0.1	0.3	1.1	1.6	3.3	-
TP, TPD 50-100/4	0.1	0.1	0.1	0.7	1.3	2.9	-
TP, TPD 50-115/4	0.1	0.1	0.1	0.8	1.4	3.0	-
TP, TPD 50-130/4	0.1	0.1	0.1	0.9	1.4	3.0	-
TP, TPD 50-180/4	0.1	0.1	0.1	0.8	1.3	3.0	-









Pump type (60 Hz)	p [bar]						
	20 °C	60 °C	90 °C	110 °C	120 °C	140 °C	150 °C
TP, TPD 50-240/4	0.1	0.1	0.2	0.9	1.5	3.1	-
TP, TPD 50-270/4	0.1	0.1	0.3	1.0	1.6	3.2	-
TP, TPD 50-340/4	0.1	0.2	0.7	1.4	2.0	3.6	-
TP 65-40/4	0.4	0.6	1.1	1.9	2.4	4.1	-
TP 65-80/4	0.7	0.9	1.4	2.2	2.7	4.4	-
TP, TPD 65-130/4	0.1	0.1	0.1	0.6	1.2	2.8	-
TP, TPD 65-150/4	0.1	0.1	0.1	0.6	1.2	2.8	-
TP, TPD 65-190/4	0.1	0.1	0.1	0.6	1.2	2.8	-
TP, TPD 65-230/4	0.1	0.1	0.1	0.7	1.3	2.9	-
TP, TPD 65-310/4	0.1	0.1	0.1	0.7	1.3	2.9	-
TP, TPD 65-330/4	0.1	0.1	0.1	0.3	0.8	2.5	-
TP 80-40/4	1.5	1.7	2.2	3.0	3.5	5.2	-
TP 80-80/4	1.6	1.8	2.3	3.1	3.6	5.3	-
TP, TPD 80-110/4	0.1	0.1	0.1	0.8	1.4	3.0	-
TP, TPD 80-150/4	0.1	0.1	0.1	0.8	1.3	2.9	-
TP, TPD 80-170/4	0.1	0.1	0.1	0.8	1.3	3.0	-
TP, TPD 80-230/4	0.1	0.1	0.3	1.0	1.6	3.2	-
TP, TPD 80-280/4	0.1	0.1	0.2	1.0	1.5	3.1	-
TP, TPD 80-340/4	0.1	0.1	0.3	1.0	1.6	3.2	-
TP, TPD 80-410/4	0.1	0.1	0.5	1.2	1.8	3.4	-
TP, TPD 80-460/4	0.1	0.1	0.6	1.3	1.9	3.5	-
TP, TPD 80-510/4	0.1	0.2	0.7	1.5	2.0	3.6	-
TP 100-40/4	1.4	1.6	2.1	2.9	3.4	5.1	-
TP 100-90/4	0.1	0.1	0.2	0.9	1.5	3.1	-
TP, TPD 100-100/4	0.1	0.1	0.2	0.9	1.5	3.1	-
TP, TPD 100-130/4	0.1	0.1	0.3	1.0	1.6	3.2	-
TP, TPD 100-150/4	0.1	0.1	0.6	1.3	1.9	3.5	-
TP, TPD 100-170/4	0.1	0.1	0.6	1.3	1.9	3.5	-
TP, TPD 100-200/4	0.1	0.1	0.4	1.1	1.7	3.3	4.6
TP, TPD 100-240/4	0.1	0.1	0.6	1.3	1.9	3.5	4.8
TP, TPD 100-260/4	0.6	0.8	1.3	2.1	2.7	4.3	5.6
TP, TPD 100-290/4	0.5	0.7	1.2	2.0	2.5	4.1	5.4
TP, TPD 100-340/4	0.6	0.8	1.3	2.0	2.6	4.2	5.5
TP, TPD 100-350/4	0.2	0.4	0.9	1.7	2.3	3.9	5.2
TP, TPD 100-390/4	0.7	0.9	1.4	2.1	2.7	4.3	5.6
TP, TPD 100-470/4	0.9	1.1	1.6	2.3	2.9	4.5	5.8
TP 100-560/4	0.1	0.3	0.7	1.7	2.2	3.8	5.1
TP 125-80/4	0.1	0.1	0.1	0.8	1.4	3.0	-









Pump type (60 Hz)	p [bar]						
	20 °C	60 °C	90 °C	110 °C	120 °C	140 °C	150 °C
TP 125-110/4	0.1	0.1	0.2	0.9	1.5	3.1	-
TP 125-135/4	0.1	0.1	0.3	1.1	1.6	3.3	-
TP, TPD 125-130/4	0.1	0.1	0.3	1.0	1.6	3.2	-
TP, TPD 125-160/4	0.1	0.1	0.3	1.1	1.6	3.2	-
TP, TPD 125-200/4	0.1	0.1	0.2	0.9	1.4	3.1	-
TP, TPD 125-230/4	0.1	0.1	0.4	1.1	1.7	3.3	-
TP 125-220/4	0.1	0.1	0.4	1.1	1.7	3.3	4.5
TP, TPD 125-280/4	0.1	0.1	0.4	1.1	1.7	3.3	4.5
TP, TPD 125-340/4	0.1	0.1	0.5	1.2	1.8	3.4	4.6
TP, TPD 125-365/4	0.3	0.5	1.0	1.7	2.3	3.9	5.2
TP, TPD 125-420/4	0.1	0.1	0.3	1.0	1.6	3.2	4.5
TP, TPD 125-480/4	0.1	0.1	0.5	1.2	1.8	3.4	4.7
TP 125-550/4	0.1	0.3	0.7	1.7	2.2	3.8	5.1
TP 125-580/4	0.1	0.3	0.7	1.7	2.2	3.8	5.1
TP 150-130/4	0.1	0.1	0.5	1.2	1.8	3.4	-
TP 150-160/4	0.1	0.2	0.7	1.5	2.0	3.6	-
TP 150-200/4	0.2	0.4	0.9	1.6	2.1	3.8	-
TP 150-220/4	0.3	0.5	1.0	1.7	2.3	3.9	-
TP, TPD 150-180/4	0.1	0.2	0.7	1.4	1.9	3.6	4.9
TP, TPD 150-210/4	0.1	0.2	0.7	1.4	2.0	3.6	4.9
TP, TPD 150-240/4	0.1	0.2	0.7	1.5	2.0	3.6	4.9
TP, TPD 150-300/4	0.1	0.3	0.8	1.5	2.1	3.7	5.0
TP, TPD 150-340/4	0.1	0.3	0.8	1.5	2.1	3.7	5.0
TP 150-360/4	0.3	0.5	1.0	1.8	2.3	4.0	5.3
TP 150-400/4	0.1	0.1	0.1	0.8	1.4	3.1	4.4
TP 150-440/4	0.1	0.1	0.4	1.1	1.7	3.3	4.6
TP 150-480/4	0.1	0.1	0.5	1.3	1.8	3.4	4.7
TP 150-610/4	0.1	0.2	0.7	1.4	2.0	3.6	4.9
TP 150-700/4	0.1	0.3	0.8	1.5	2.1	3.7	5.0
TP 150-810/4	0.3	0.4	0.9	1.7	2.2	3.8	5.1
TP 150-960/4	0.4	0.6	1.1	1.8	2.3	3.8	5.1
TP 200-80/4	0.9	1.1	1.6	2.3	2.9	4.5	-
TP 200-110/4	0.5	0.6	1.1	1.9	2.4	4.0	-
TP 200-140/4	0.3	0.5	1.0	1.7	2.3	3.9	-
TP 200-190/4	0.2	0.4	0.9	1.6	2.2	3.8	-
TP 200-210/4	0.1	0.2	0.7	1.4	2.0	3.6	-
TP 200-250/4	0.9	1.0	1.5	2.3	2.8	4.4	5.7
TP 200-280/4	0.7	0.9	1.4	2.1	2.7	4.3	5.6









Pump type (60 Hz)	p [bar]						
	20 °C	60 °C	90 °C	110 °C	120 °C	140 °C	150 °C
TP 200-320/4	0.6	0.8	1.3	2.0	2.6	4.2	5.5
TP 200-360/4	0.4	0.6	1.1	1.8	2.4	4.0	5.3
TP 200-390/4	0.3	0.5	1.0	1.7	2.2	3.9	5.2
TP 200-400/4	0.1	0.1	0.6	1.3	1.9	3.6	4.9
TP 200-430/4	0.1	0.1	0.6	1.4	1.9	3.6	4.9
TP 200-440/4	0.1	0.2	0.7	1.5	2.0	3.7	5.0
TP 200-490/4	0.1	0.1	0.1	0.8	1.4	3.1	4.4
TP 200-500/4	0.2	0.4	0.9	1.6	2.2	3.9	5.2
TP 200-540/4	0.1	0.1	0.1	0.8	1.4	3.1	4.4
TP 200-600/4	0.1	0.1	0.1	0.8	1.4	3.1	4.4
TP 200-680/4	0.1	0.1	0.1	0.8	1.4	3.1	4.4
TP 200-770/4	0.1	0.2	0.7	1.4	2.0	3.7	5.0
TP 300-230/4	0.8	1.0	1.4	2.4	2.9	4.5	5.8
TP 300-270/4	0.7	0.9	1.3	2.3	2.8	4.4	5.7
TP 300-360/4	0.7	0.9	1.3	2.3	2.8	4.4	5.7
TP 300-370/4	0.8	1.0	1.4	2.4	2.9	4.5	5.8
TP 300-440/4	0.8	1.0	1.4	2.4	2.9	4.5	5.8
TP 300-550/4	0.8	1.0	1.4	2.4	2.9	4.5	5.8
TP 300-630/4	0.8	1.0	1.4	2.4	2.9	4.5	5.8
TP 300-640/4	0.7	0.9	1.3	2.3	2.8	4.4	5.7
TP 300-750/4	0.7	0.9	1.3	2.3	2.8	4.4	5.7
TP 350-400/4	2.0	2.2	2.6	3.6	4.1	5.7	7.0
TP 350-450/4	2.0	2.2	2.6	3.6	4.1	5.7	7.0
TP 350-540/4	2.0	2.2	2.6	3.6	4.1	5.7	7.0
TP 350-680/4	2.0	2.2	2.6	3.6	4.1	5.7	7.0
TP 350-450/4	2.0	2.2	2.6	3.6	4.1	5.7	7.0
TP 350-540/4	2.0	2.2	2.6	3.6	4.1	5.7	7.0
TP 350-680/4	2.0	2.2	2.6	3.6	4.1	5.7	7.0

A.6. TP, TPE pumps from 11 kW and up suspended in the pipes

Pump type	PN 16	PN 25	P2 [kW]								
50 Hz											
TP, TPE 65-460/2	•	-	11	-	-	-	-	-	-	•	-
TP, TPE 65-550/2	•	-	15	-	-	-	-	-	-	•	-
TP, TPE 65-660/2	•	-	18.5	-	-	-	-	-	-	•	-
TP, TPE 65-720/2	•	-	22	-	-	-	-	-	-	•	-
TP, TPE 80-330/2	•	-	11	-	-	-	-	-	-	•	-
TP, TPE 80-400/2	•	-	15	-	-	-	-	-	-	•	-
TP, TPE 80-520/2	•	-	18.5	-	-	-	-	-	-	•	-
TP, TPE 80-570/2	•	-	22	-	-	-	-	-	-	•	-
TP, TPE 100-250/2	•	-	11	-	-	-	-	-	-	•	-
TP, TPE 100-310/2	•	-	15	-	-	-	-	-	-	•	-
TP, TPE 100-360/2	•	-	18.5	-	-	-	-	-	-	•	-
TP, TPE 100-390/2	•	-	22	-	-	-	-	-	-	•	-
TP, TPE 80-340/4	•	-	11	-	-	-	-	-	-	•	-
TP, TPE 100-250/4	•	•	11	-	-	-	-	-	-	•	-
TP, TPE 100-330/4	•	•	15	-	-	-	-	-	-	•	-
TP, TPE 100-370/4	•	•	18.5	-	-	-	-	-	-	•	-
TP 100-410/4	•	•	22	-	-	-	-	-	-	•	-
TP, TPE 125-190/4	•	•	11	-	-	-	-	-	-	•	-
TP, TPE 125-230/4	•	•	15	-	-	-	-	-	-	•	-
TP, TPE 125-300/4	•	•	18.5	-	-	-	-	-	-	•	-
TP 125-340/4	•	•	22	-	-	-	-	-	-	•	-
TP, TPE 150-200/4	•	•	15	-	-	-	-	-	-	•	-
TP, TPE 150-220/4	•	•	18.5	-	-	-	-	-	-	•	-
TP 150-250/4	•	•	22	-	-	-	-	-	-	•	-
TP, TPE 150-260/4	-	•	18.5	•	-	-	-	-	-	-	-
TP 150-280/4	-	•	22	•	-	-	-	-	-	-	-
TP 150-340/4	-	•	30	•	-	-	-	-	-	-	-
TP 150-390/4	-	•	37	•	-	-	-	-	-	-	-
TP 150-450/4	-	•	45	•	-	-	-	-	-	-	-
TP 150-520/4	-	•	55	•	-	-	-	-	-	-	-
TP 150-660/4	-	•	75	•	-	-	-	-	-	-	-
TP, TPE 200-160/4	-	•	15	•	-	-	-	-	-	-	-
TP, TPE 200-190/4	-	•	18.5	•	-	-	-	-	-	-	-
TP 200-200/4	-	•	22	•	-	-	-	-	-	-	-
TP 200-240/4	-	•	30	•	-	-	-	-	-	-	-

Pump type	PN 16	PN 25	P2 [kW]								
TP 200-270/4	-	•	45			•					-
TP 200-320/4	-	•	55			•					-
TP 200-330/4	-	•	37			•					-
TP 200-360/4	-	•	45			•					-
TP 200-400/4	-	•	55			•					-
TP 200-410/4	-	•	75			•					-
TP 200-470/4	-	•	75			•					-
TP 300-190/4	-	•	30			•					-
TP 300-220/4	-	•	37			•					-
TP 300-250/4	-	•	45			•					-
TP 300-290/4	-	•	55			•					-
TP 300-390/4	-	•	75			•					-
TP 300-420/4	-	•	90			•					-
TP 300-430/4	-	•	110			•					-
TP 300-500/4	-	•	132			•					-
TP 300-550/4	-	•	160			•					-
TP 350-230/4	-	•	55			•					-
TP 350-280/4	-	•	75			•					-
TP 350-310/4	-	•	90			•					-
TP 350-360/4	-	•	110			•					-
TP 350-420/4	-	•	132			•					-
TP 350-480/4	-	•	160			•					-
TP 350-530/4	-	•	200			•					-
TP 350-650/4	-	•	250			•					-
TP 350-780/4	-	•	315			•					-
60 Hz											
TP, TPE 65-480/2	•	-	11			-					•
TP, TPE 65-540/2	•	-	15			-					•
TP, TPE 65-630/2	•	-	18.5			-					•
TP, TPE 65-740/2	•	-	22			-					•
TP, TPE 80-330/2	•	-	11			-					•
TP, TPE 80-400/2	•	-	15			-					•
TP, TPE 80-480/2	•	-	18.5			-					•
TP, TPE 80-530/2	•	-	22			-					•
TP, TPE 100-300/2	•	-	11			-					•
TP, TPE 100-370/2	•	-	15			-					•
TP, TPE 100-350/2	•	-	18.5			-					•
TP, TPE 100-380/2	•	-	22			-					•

Pump type	PN 16	PN 25	P2 [kW]								
TP, TPE 80-340/4	●	-	11							●	
TP, TPE 80-410/4	●	-	15							●	
TP, TPE 80-460/4	●	-	18.5							●	
TP 80-510/4	●	-	22							●	
TP, TPE 100-240/4	●	●	11		●					●	
TP, TPE 100-260/4	●	-	11							●	
TP, TPE 100-290/4	●	●	15		●					●	
TP, TPE 100-340/4	●	●	18.5		●					●	
TP 100-350/4	●	-	22							●	
TP 100-390/4	●	●	22		●					●	
TP 100-470/4	-	●	30		●					-	
TP 100-560/4	-	●	37		●					-	
TP, TPE 125-200/4	●	-	11							●	
TP, TPE 125-230/4	●	-	15							●	
TP, TPE 125-220/4	-	●	15							●	
TP, TPE 125-280/4	●	●	18.5							●	
TP 125-340/4	●	●	22							●	
TP 125-365/4	-	●	30		●					-	
TP 125-420/4	-	●	30		●					-	
TP 125-480/4	-	●	37		●					-	
TP 125-550/4	-	●	45		●					-	
TP 125-580/4	-	●	55		●					-	
TP, TPE 150-180/4	●	●	15							●	
TP, TPE 150-210/4	●	●	18.5							●	
TP 150-240/4	●	●	22							●	
TP 150-300/4	-	●	30		●					-	
TP 150-340/4	-	●	37		●					-	
TP 150-360/4	-	●	30		●					-	
TP 150-400/4	-	●	37		●					-	
TP 150-440/4	-	●	45		●					-	
TP 150-480/4	-	●	55		●					-	
TP 150-610/4	-	●	75		●					-	
TP 150-810/4	-	●	110		●					-	
TP 150-960/4	-	●	132		●					-	
TP 200-250/4	-	●	30		●					-	
TP 200-400/4	-	●	75		●					-	
TP 200-430/4	-	●	55		●					-	
TP 300-230/4	-	●	45		●					-	

Pump type	PN 16	PN 25	P2 [kW]								
TP 300-270/4	-	•	55			•					-
TP 300-360/4	-	•	75			•					-
TP 300-370/4	-	•	90			•					-
TP 300-440/4	-	•	110			•					-
TP 300-550/4	-	•	132			•					-
TP 300-630/4	-	•	160			•					-
TP 300-640/4	-	•	200			•					-
TP 300-750/4	-	•	250			•					-
TP 350-280/4	-	•	90			•					-
TP 350-330/4	-	•	110			•					-
TP 350-390/4	-	•	132			•					-
TP 350-440/4	-	•	160			•					-
TP 350-450/4	-	•	160			•					-
TP 350-540/4	-	•	200			•					-
TP 350-680/4	-	•	250			•					-

A.7. Dimensions of base plates, TP, TPE Series 200

Pump type	Hexagon head screws
50 Hz: TP, TPE 32 TP, TPE 40 TP, TPE 50 TP 65-60/2 TP, TPE 65-120/2 TP 65-180/2	60 Hz: TP 32 TP 40 TP 50 TP 65-80/2, 65-160/2, 65-240/2 2 x M12 x 20 mm
50 Hz: TP 65-30/4 TP, TPE 65-60/4 TP, TPE 80 TP, TPE 100	60 Hz: TP 65-40/4, 65-80/4 TP 80 TP 100 2 x M16 x 30 mm

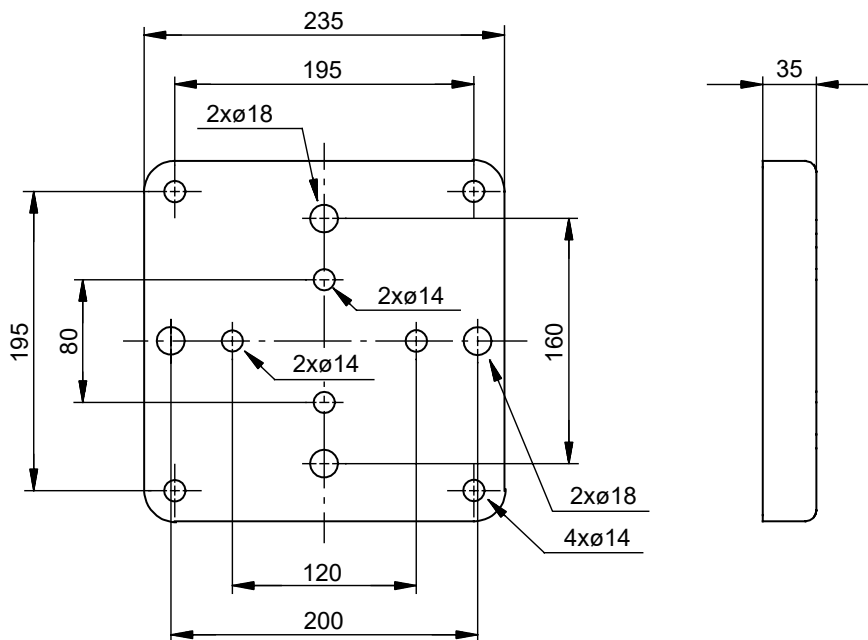

TMD 09835

A.8. Dimensions of base plates, TP, TPE Series 300

Pump type	Hexagon head screws
50 Hz:	
TP, TPE 32	60 Hz:
TP, TPE 40	TP, TPE 32
TP, TPE 50	TP, TPE 40
TP, TPE 65	TP, TPE 50
TP, TPE 80-xx/2	TP, TPE 65
TP, TPE 80-70/4	TP, TPE 80-xx/2
TP, TPE 80-90/4	TP 80-110/4
TP, TPE 80-110/4	TP, TPE 80-150/4
TP, TPE 80-150/4	TP, TPE 80-170/4
TP, TPE 80-170/4	TP, TPE 100-230/2
TP, TPE 100-160/2	TP, TPE 100-300/2
TP, TPE 100-200/2	TP, TPE 100-370/2
TP, TPE 100-240/2	

2 x M16 x 30 mm

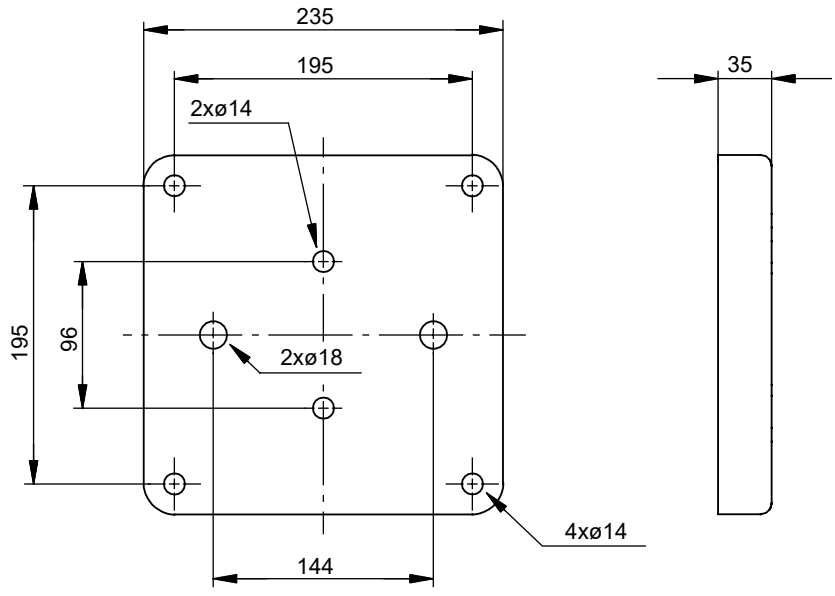

TIM003755

Pump type **Hexagon head screws**

50 Hz:	60 Hz:
TP, TPE 80-240/4	TP, TPE 80-230/4
TP, TPE 80-270/4	TP, TPE 80-280/4
TP, TPE 80-340/4	TP, TPE 80-340/4
TP, TPE 80-340/4	TP, TPE 80-410/4
TP, TPE 100-250/2	TP, TPE 80-460/4
TP, TPE 100-310/2	TP, TPE 80-510/4
TP, TPE 100-360/2	TP, TPE 100-350/2
TP, TPE 100-390/2	TP, TPE 100-380/2
TP, TPE 100-480/2	TP, TPE 100-530/2
TP 100-530/2	TP, TPE 100-630/2
TP 100-650/2	TP, TPE 100-700/2
TP 100-800/2	TP 100-760/2
TP 100-950/2	TP 100-940/2
TP 100-1040/2	TP 100-1040/2
TP 100-1200/2	TP 100-1200/2
TP 100-1410/2	TP 100-1360/2
TP, TPE 100-xx/4	TP 100-1510/2
TP, TPE 125-xx/4	TP, TPE 100-xx/4
TP, TPE 150-xx/4	TP, TPE 125-xx/4
TP 125-xx/6	TP, TPE 150-xx/4
TP 150-xx/6	TP, TPE 100-260/4
	TP 100-350/4

2 x M16 x 30 mm

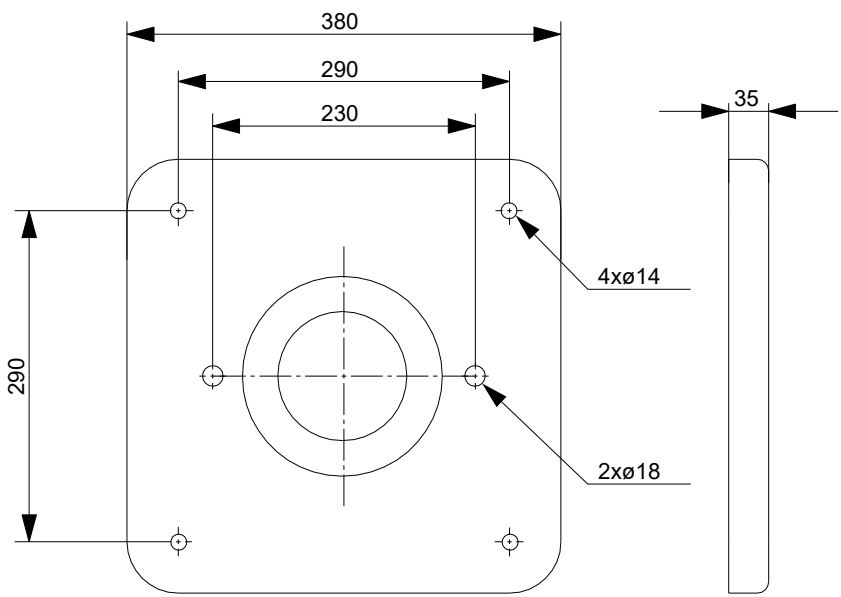

TM028869

A.9. Dimensions of base plates, TPD, TPED Series 300

Pump type	Hexagon head screws
50 Hz:	
TPD, TPED 32	
TPD, TPED 40	
TPD, TPED 50	
TPD, TPED 65	
TPD, TPED 80-xx/2	
TPD, TPED 80-70/4	
TPD, TPED 80-90/4	
TPD, TPED 80-110/4	
TPD, TPED 80-150/4	
TPD, TPED 80-170/4	
TPD, TPED 100-160/2	
TPD, TPED 100-200/2	
TPD, TPED 100-240/2	
60 Hz:	
TPD 32	
TPD 40	
TPD 50	
TPD 65	
TPD 80-xx/2	
TPD 80-110/4	
TPD 80-150/4	
TPD 80-170/4	
TPD 100-230/2	
TPD 100-300/2	
TPD 100-370/2	
	4 x M16 x 30 m

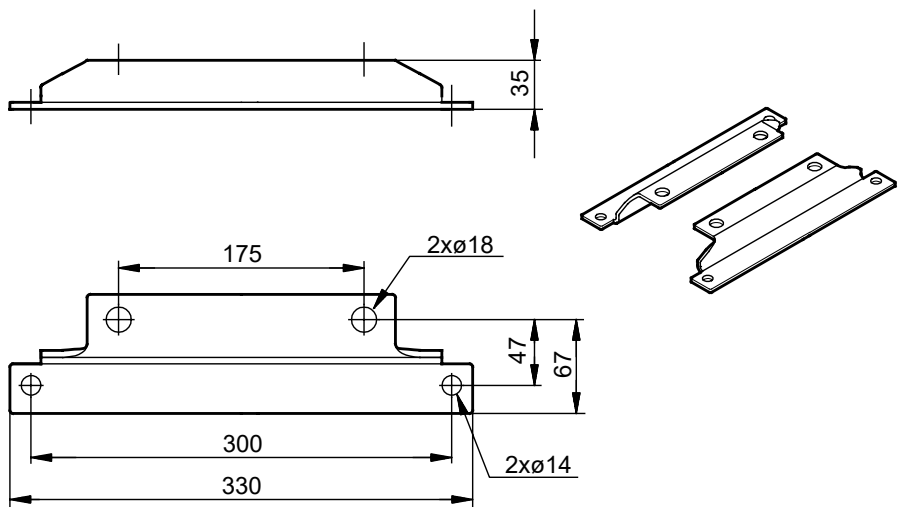

TM025336

Pump type	Hexagon head screws
50 Hz:	
TPD, TPED 100-250/2	
TPD, TPED 100-310/2	
TPD, TPED 100-360/2	
TPD, TPED 100-390/2	
TPD, TPED 100-65/4	
TPD, TPED 100-70/4	
TPD, TPED 100-90/4	
TPD, TPED 100-110/4	
TPD, TPED 100-130/4	
TPD, TPED 100-170/4	
60 Hz:	
TPD 100-350/2	
TPD 100-380/2	
TPD 100-530/2	
TPD 100-630/2	
TPD 100-700/2	
TPD 100-100/4	
TPD 100-130/4	
TPD 100-150/4	
TPD 100-170/4	

4 x M16 x 30 mm

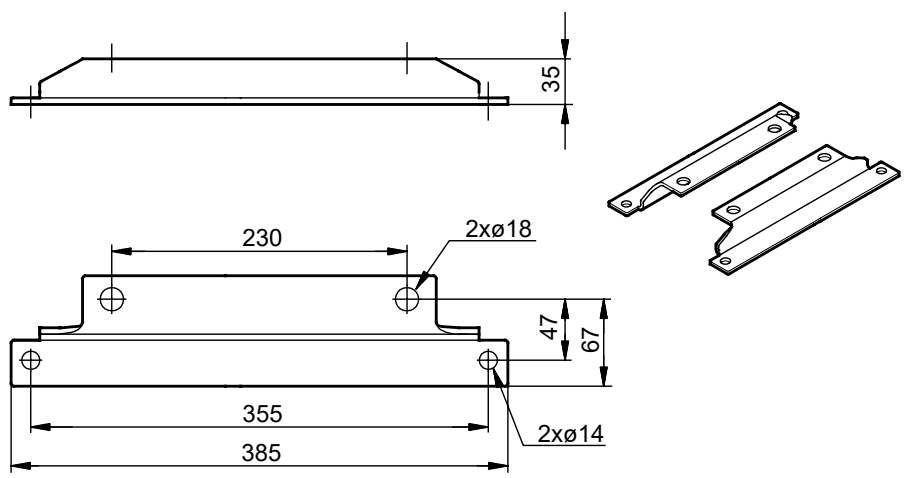

TM028870

Appendix B

B.1. 中国 RoHS

产品中有害物质的名称及含量

部件名称	有害物质					
	铅 (Pb)	汞 (Hg)	镉 (Cd)	六价铬 (Cr6+)	多溴联苯 (PBB)	多溴联苯醚 (PBDE)
泵壳	X	0	0	0	0	0
紧固件	X	0	0	0	0	0
管件	X	0	0	0	0	0
定子	X	0	0	0	0	0
转子	X	0	0	0	0	0

本表格依据 SJ/T 11364 的规定编制

O: 表示该有害物质在该部件所有均质材料中的含量均在 GB/T 26572 规定的限量要求以下。
X: 表示该有害物质至少在该部件的某一均质材料中的含量超出 GB/T 26572 该规定的限量要求。

 该产品环保使用期限为 10 年，标识如左图所示。
此环保期限只适用于产品在安装与使用说明书中所规定的条件下工作

Argentina

Bombas GRUNDFOS de Argentina S.A.
Ruta Panamericana km. 37.500 Industrias
1619 - Garin Pcia. de B.A.
Tel.: +54-3327 414 444
Fax: +54-3327 45 3190

Australia

GRUNDFOS Pumps Pty. Ltd.
P.O. Box 2040
Regency Park
South Australia 5942
Tel.: +61-8-8461-4611
Fax: +61-8-8340-0155

Austria

GRUNDFOS Pumpen Vertrieb
Ges.m.b.H.
Grundfosstraße 2
A-5082 Grödig/Salzburg
Tel.: +43-6246-883-0
Fax: +43-6246-883-30

Belgium

N.V. GRUNDFOS Bellux S.A.
Boomssesteenweg 81-83
B-2630 Aartselaar
Tel.: +32-3-870 7300
Fax: +32-3-870 7301

Bosnia and Herzegovina

GRUNDFOS Sarajevo
Zmajia od Bosne 7-7A
BiH-71000 Sarajevo
Tel.: +387 33 592 480
Fax: +387 33 590 465
www.ba.grundfos.com
E-mail: grundfos@bih.net.ba

Brazil

BOMBAS GRUNDFOS DO BRASIL
Av. Humberto de Alencar Castelo
Branco, 630
CEP 09850 - 300
São Bernardo do Campo - SP
Tel.: +55-11 4393 5533
Fax: +55-11 4343 5015

Bulgaria

Grundfos Bulgaria EOOD
Slatina District
Iztocna Tangenta street no. 100
BG - 1592 Sofia
Tel.: +359 2 49 22 200
Fax: +359 2 49 22 201
E-mail: bulgaria@grundfos.bg

Canada

GRUNDFOS Canada inc.
2941 Brighton Road
Oakville, Ontario
L6H 6C9
Tel.: +1-905 829 9533
Fax: +1-905 829 9512

China

GRUNDFOS Pumps (Shanghai) Co. Ltd.
10F The Hub, No. 33 Suhong Road
Minhang District
Shanghai 201106 PRC
Tel.: +86 21 612 252 22
Fax: +86 21 612 253 33

Columbia

GRUNDFOS Colombia S.A.S.
Km 1.5 vía Siberia-Cota Conj. Potrero
Chico,
Parque Empresarial Arcos de Cota Bd.
1A.
Cota, Cundinamarca
Tel.: +57(1)-2913444
Fax: +57(1)-8764586

Croatia

GRUNDFOS CROATIA d.o.o.
Buzinski prilaz 38, Buzin
HR-10010 Zagreb
Tel.: +385 1 6595 400
Fax: +385 1 6595 499
www.hr.grundfos.com

Czech Republic

GRUNDFOS Sales Czechia and Slovakia
s.r.o.
Čajkovského 21
779 00 Olomouc
Tel.: +420-585-716 111

Denmark

GRUNDFOS DK A/S
Martin Bachs Vej 3
DK-8850 Bjerringbro
Tel.: +45-87 50 50 50
Fax: +45-87 50 51 51
E-mail: info_GDK@grundfos.com
www.grundfos.com/DK

Estonia

GRUNDFOS Pumps Eesti OÜ
Peterburi tee 92G
11415 Tallinn
Tel.: + 372 606 1690
Fax: + 372 606 1691

Finland

OY GRUNDFOS Pumput AB
Trukkikujua 1
FI-01360 Vantaa
Tel.: +358-(0) 207 889 500

France

Pompes GRUNDFOS Distribution S.A.
Parc d'Activités de Chesnes
57, rue de Malacombe
F-38290 St. Quentin Fallavier (Lyon)
Tel.: +33-4 74 82 15 15
Fax: +33-4 74 94 10 51

Germany

GRUNDFOS GMBH
Schlüterstr. 33
40699 Erkrath
Tel.: +49-(0) 211 929 69-0
Fax: +49-(0) 211 929 69-3799
E-mail: infoservice@grundfos.de
Service in Deutschland:
kundendienst@grundfos.de

Greece

GRUNDFOS Hellas A.E.B.E.
20th km. Athinon-Markopoulou Av.
P.O. Box 71
GR-19002 Peania
Tel.: +0030-210-66 83 400
Fax: +0030-210-66 46 273

Hong Kong

GRUNDFOS Pumps (Hong Kong) Ltd.
Unit 1, Ground floor, Siu Wai industrial
Centre
29-33 Wing Hong Street & 68 King Lam
Street, Cheung Sha Wan
Kowloon
Tel.: +852-27861706 / 27861741
Fax: +852-27858664

Hungary

GRUNDFOS Hungária Kft.
Tópark u. 8
H-2045 Törökbalint
Tel.: +36-23 511 110
Fax: +36-23 511 111

India

GRUNDFOS Pumps india Private Limited
118 Old Mahabalipuram Road
Thoraipakkam
Chennai 600 097
Tel.: +91-44 2496 6800

Indonesia

PT GRUNDFOS Pompa
Graha intrub Lt. 2 & 3
Jln. Cililitan Besar No.454. Makasar,
Jakarta Timur
ID-Jakarta 13650
Tel.: +62 21-469-51900
Fax: +62 21-460 6910 / 460 6901

Ireland

GRUNDFOS (Ireland) Ltd.
Unit A, Merrywell Business Park
Ballymount Road Lower
Dublin 12
Tel.: +353-1-4089 800
Fax: +353-1-4089 830

Italy

GRUNDFOS Pompe Italia S.r.l.
Via Gran Sasso 4
I-20060 Truccazzano (Milano)
Tel.: +39-02-95838112
Fax: +39-02-95309290 / 95838461

Japan

GRUNDFOS Pumps K.K.
1-2-3, Shin-Miyakoda, Kita-ku
Hamamatsu
431-2103 Japan
Tel.: +81 53 428 4760
Fax: +81 53 428 5005

Kazakhstan

Grundfos Kazakhstan LLP
7' Kyz-Zhibek Str., Kok-Tobe micr.
KZ-050020 Almaty Kazakhstan
Tel.: +7 (727) 227-98-55/56

Korea

GRUNDFOS Pumps Korea Ltd.
6th Floor, Aju Building 679-5
Yeoksam-dong, Kangnam-ku, 135-916
Seoul, Korea
Tel.: +82-2-5317 600
Fax: +82-2-5633 725

Latvia

SIA GRUNDFOS Pumps Latvia
Deglava biznesa centrs
Augusta Deglava ielā 60
LV-1035, Rīga,
Tel.: + 371 714 9640, 7 149 641
Fax: + 371 914 9646

Lithuania

GRUNDFOS Pumps UAB
Smolensko g. 6
LT-03201 Vilnius
Tel.: + 370 52 395 430
Fax: + 370 52 395 431

Malaysia

GRUNDFOS Pumps Sdn. Bhd.
7 Jalan Peguam U1/25
Glenmarie Industrial Park
40150 Shah Alam, Selangor
Tel.: +60-3-5569 2922
Fax: +60-3-5569 2866

Mexico

Bombas GRUNDFOS de México
S.A. de C.V.
Boulevard TLC No. 15
Parque industrial Stiva Aeropuerto
Apodaca, N.L. 66600
Tel.: +52-81-8144 4000
Fax: +52-81-8144 4010

Netherlands

GRUNDFOS Netherlands
Veluwezoom 35
1326 AE Almere
Postbus 22015
1302 CA ALMERE
Tel.: +31-88-478 6336
Fax: +31-88-478 6332
E-mail: info_gnl@grundfos.com

New Zealand

GRUNDFOS Pumps NZ Ltd.
17 Beatrice Tinsley Crescent
North Harbour Industrial Estate
Albany, Auckland
Tel.: +64-9-415 3240
Fax: +64-9-415 3250

Norway

GRUNDFOS Pumper A/S
Strømsveien 344
Postboks 235, Leirdal
N-1011 Oslo
Tel.: +47-22 90 47 00
Fax: +47-22 32 21 50

Poland

GRUNDFOS Pompy Sp. z o.o.
ul. Klonowa 23
Baranowo k. Poznania
PL-62-081 Przeźmierowo
Tel.: (+48-61) 650 13 00
Fax: (+48-61) 650 13 50

Portugal

Bombas GRUNDFOS Portugal, S.A.
Rua Calvet de Magalhães, 241
Apartado 1079
P-2770-153 Paço de Arcos
Tel.: +351-21-440 76 00
Fax: +351-21-440 76 90

Romania

GRUNDFOS Pompe România SRL
S-PARK BUSINESS CENTER, Clădirea
A2, etaj 2
Str. Tipografilor, Nr. 11-15, Sector 1, Cod
013714
Bucuresti, Romania
Tel.: 004 021 2004 100
E-mail: romania@grundfos.ro

Serbia

Grundfos Srbija d.o.o.
Orladijskih brigada 90b
11070 Novi Beograd
Tel.: +381 11 2258 740
Fax: +381 11 2281 769
www.rs.grundfos.com

Singapore

GRUNDFOS (Singapore) Pte. Ltd.
25 Jalan Tukang
Singapore 619264
Tel.: +65-6681 9688
Fax: +65-6681 9689

Slovakia

GRUNDFOS s.r.o.
Prievozská 4D 821 09 BRATISLAVA
Tel.: +421 2 5020 1426
sk.grundfos.com

Slovenia

GRUNDFOS LJUBLJANA, d.o.o.
Leskoškova 9e, 1122 Ljubljana
Tel.: +386 (0) 1 568 06 10
Fax: +386 (0)1 568 06 19
E-mail: tehnika-si@grundfos.com

South Africa

GRUNDFOS (PTY) LTD
16 Lascelles Drive, Meadowbrook Estate
1609 Germiston, Johannesburg
Tel.: (+27) 10 248 6000
Fax: (+27) 10 248 6002
E-mail: lgradidge@grundfos.com

Spain

Bombas GRUNDFOS España S.A.
Camino de la Fuentevilla, s/n
E-28110 Algete (Madrid)
Tel.: +34-91-848 8800
Fax: +34-91-628 0465

Sweden

GRUNDFOS AB
Box 333 (Lunnagårdsgatan 6)
431 24 Mölndal
Tel.: +46 31 332 23 000
Fax: +46 31 331 94 60

Switzerland

GRUNDFOS Pumpen AG
Bruggacherstrasse 10
CH-8117 Fällanden/ZH
Tel.: +41-44-806 8111
Fax: +41-44-806 8115

Taiwan

GRUNDFOS Pumps (Taiwan) Ltd.
7 Floor, 219 Min-Chuan Road
Taichung, Taiwan, R.O.C.
Tel.: +886-4-2305 0868
Fax: +886-4-2305 0878

Thailand

GRUNDFOS (Thailand) Ltd.
92 Chaloe Phrakiat Rama 9 Road
Dokmai, Pravej, Bangkok 10250
Tel.: +66-2-725 8999
Fax: +66-2-725 8998

Turkey

GRUNDFOS POMPA San. ve Tic. Ltd.
Sti.
Gebze Organize Sanayi Bölgesi
İhsan dede Caddesi
2. yol 200, Sokak No. 204
41490 Gebze/ Kocaeli
Tel.: +90 - 262-679 7979
Fax: +90 - 262-679 7905
E-mail: satis@grundfos.com

Ukraine

ТОВ "ГРУНДФОС УКРАЇНА"
Бізнес Центр Європа
Столичне шосе, 103
м. Київ, 03131, Україна
Tel.: (+38 044) 237 04 00
Fax: (+38 044) 237 04 01
E-mail: ukraine@grundfos.com

United Arab Emirates

GRUNDFOS Gulf Distribution
P.O. Box 16768
Jebel Ali Free Zone, Dubai
Tel.: +971 4 8815 166
Fax: +971 4 8815 136

United Kingdom

GRUNDFOS Pumps Ltd.
Grovebury Road
Leighton Buzzard/Beds. LU7 4TL
Tel.: +44-1525-850000
Fax: +44-1525-850011

U.S.A.

Global Headquarters for WU
856 Koomey Road
Brookshire, Texas 77423 USA
Phone: +1-630-236-5500

Uzbekistan

Grundfos Tashkent, Uzbekistan
The Representative Office of Grundfos
Kazakhstan in Uzbekistan
38a, Oybek street, Tashkent
Tel.: (+998) 71 150 3290 / 71 150 3291
Fax: (+998) 71 150 3292

96404999 12.2023

ECM: 1383319

www.grundfos.com

GRUNDFOS 

Trademarks displayed in this material, including but not limited to Grundfos and the Grundfos logo, are registered trademarks owned by The Grundfos Group. © 2023 Grundfos Holding A/S, all rights reserved.