

TPE Series 1000

Installation and operating instructions



English (US) Installation and operating instructions

Original installation and operating instructions.

CONTENTS

	Page		Page
1. Limited warranty	3	19. Megging	31
2. Symbols used in this document	3	20. Technical data, single-phase motors	31
3. Abbreviations and definitions	3	20.1 Supply voltage	31
4. General information	4	20.2 Leakage current	31
4.1 Radio communication	4	21. Technical data, three-phase motors	31
4.2 Battery	4	21.1 Supply voltage	31
5. Mechanical installation	4	21.2 Leakage current	31
5.1 Mounting	4	22. Inputs/outputs	31
5.2 Cable entries	4	23. Other technical data	32
5.3 Ensuring motor cooling	4	23.1 Torques	32
5.4 Outdoor installation	4	23.2 Sound pressure level	32
5.5 Drain holes	4	24. Disposal	32
6. Electrical installation	5		
6.1 Protection against electric shock, indirect contact	5		
6.2 Mains supply	5		
6.3 Additional protection	6		
6.4 Connection terminals	7		
6.5 Signal cables	9		
6.6 Bus connection cable	9		
7. Operating conditions	9		
7.1 Maximum number of starts and stops	9		
7.2 Ambient temperature	9		
7.3 Installation altitude	10		
7.4 Air humidity	10		
7.5 Motor cooling	10		
8. User interfaces	10		
9. Standard control panel	11		
9.1 Setpoint setting	11		
10. Grundfos GO Remote	12		
10.1 Communication	12		
10.2 Menu overview for Grundfos GO Remote	13		
11. Description of selected functions	15		
11.1 Setpoint	15		
11.2 Operating mode	15		
11.3 Set manual speed	15		
11.4 Control mode	15		
11.5 Analog inputs	18		
11.6 Pt100/1000 inputs	18		
11.7 Digital inputs	19		
11.8 Digital inputs/outputs	19		
11.9 Relay outputs	20		
11.10 Analog output	20		
11.11 Controller settings	20		
11.12 Operating range	21		
11.13 Setpoint influence	21		
11.14 Monitoring functions	24		
11.15 Special functions	24		
11.16 Communication	24		
11.17 General settings	24		
12. Assist	25		
12.1 Setup of multi-pump system	25		
13. Selection of control mode	26		
14. Changing the position of the control panel	27		
15. Bus signal	28		
16. Priority of settings	28		
17. Grundfos Eye	29		
18. Signal relays	30		

**Warning**

Prior to installation, read these installation and operating instructions. Installation and operation must comply with local regulations and accepted codes of good practice.

1. Limited warranty

Products manufactured by GRUNDFOS PUMPS CORPORATION (Grundfos) are warranted to the original user only to be free of defects in material and workmanship for a period of 24 months from date of installation, but not more than 30 months from date of manufacture. Grundfos' liability under this warranty shall be limited to repairing or replacing at Grundfos' option, without charge, F.O.B. Grundfos' factory or authorized service station, any product of Grundfos' manufacture. Grundfos will not be liable for any costs of removal, installation, transportation, or any other charges which may arise in connection with a warranty claim. Products which are sold but not manufactured by Grundfos are subject to the warranty provided by the manufacturer of said products and not by Grundfos' warranty. Grundfos will not be liable for damage or wear to products caused by abnormal operating conditions, accident, abuse, misuse, unauthorized alteration or repair, or if the product was not installed in accordance with Grundfos' printed installation and operating instructions.

To obtain service under this warranty, the defective product must be returned to the distributor or dealer of Grundfos' products from which it was purchased together with proof of purchase and installation date, failure date, and supporting installation data. Unless otherwise provided, the distributor or dealer will contact Grundfos or an authorized service station for instructions. Any defective product to be returned to Grundfos or a service station must be sent freight prepaid; documentation supporting the warranty claim and/or a Return Material Authorization must be included if so instructed.

GRUNDFOS WILL NOT BE LIABLE FOR ANY INCIDENTAL OR CONSEQUENTIAL DAMAGES, LOSSES, OR EXPENSES ARISING FROM INSTALLATION, USE, OR ANY OTHER CAUSES. THERE ARE NO EXPRESS OR IMPLIED WARRANTIES, INCLUDING MERCHANTABILITY OR FITNESS FOR A PARTICULAR PURPOSE, WHICH EXTEND BEYOND THOSE WARRANTIES DESCRIBED OR REFERRED TO ABOVE.

Some jurisdictions do not allow the exclusion or limitation of incidental or consequential damages and some jurisdictions do not allow limit actions on how long implied warranties may last. Therefore, the above limitations or exclusions may not apply to you. This warranty gives you specific legal rights and you may also have other rights which vary from jurisdiction to jurisdiction.

2. Symbols used in this document



Warning

If these safety instructions are not observed, it may result in personal injury.



Warning

If these instructions are not observed, it may lead to electric shock with consequent risk of serious personal injury or death.



Warning

The surface of the product may be so hot that it may cause burns or personal injury.

Caution

If these safety instructions are not observed, it may result in malfunction or damage to the equipment.

Note

Notes or instructions that make the job easier and ensure safe operation.

3. Abbreviations and definitions

AI	Analog input.
AL	Alarm, out of range at lower limit.
AO	Analog output.
AU	Alarm, out of range at upper limit.
Current sinking	The ability to draw current into the terminal and guide it towards GND in the internal circuitry.
Current sourcing	The ability to push current out of the terminal and into an external load which must return it to GND.
DI	Digital input.
DO	Digital output.
ELCB	Earth leakage circuit breaker.
FM	Functional module.
GDS	Grundfos Digital Sensor. Factory-fitted sensor in some Grundfos pumps.
GENIbus	Proprietary Grundfos fieldbus standard.
GFCI	Ground fault circuit interrupter. (USA and Canada).
GND	Ground.
Grundfos Eye	Status indicator light.
LIVE	Low voltage with the risk of electric shock if the terminals are touched.
OC	Open collector: Configurable open-collector output.
PE	Protective earth.
PELV	Protective extra-low voltage. A voltage that cannot exceed ELV under normal conditions and under single-fault conditions, except earth faults in other circuits.
SELV	Safety extra-low voltage. A voltage that cannot exceed ELV under normal conditions and under single-fault conditions, including earth faults in other circuits.
TPE	Pump without factory-fitted differential-pressure and temperature sensor.

4. General information

These installation and operating instructions apply to the Grundfos TPE pumps.

The pumps are fitted with frequency-controlled permanent-magnet motors for single-phase or three-phase mains connection.

4.1 Radio communication

For installation in the USA and Canada, see also page 33.

This product can communicate with the Grundfos GO Remote and other products of the same type via the built-in radio module.

In some cases, an external antenna may be required.

Only Grundfos-approved external antennas may be connected to this product, and only by a Grundfos-approved installer.

4.2 Battery

Pumps fitted with the advanced functional module (FM 300) incorporate a Li-ion battery. The Li-ion battery complies with the Battery Directive (2006/66/EC). The battery does not contain mercury, lead and cadmium.

5. Mechanical installation



Warning

Installation and operation must comply with local regulations and accepted codes of good practice.

5.1 Mounting

The pump must be secured to a solid foundation by bolts through the holes in the flange or the base plate.

Note

In order to maintain the UL mark, additional installation procedures must be followed. See page 33.

5.2 Cable entries

The motor has four M20 screwed cable entries fitted with blind plugs from factory.

The following cable glands are included:

- 2 x M20 cable gland, cable diameter $\varnothing 0.016$ " (5 mm)
- 1 x M20 cable gland, cable diameter $\varnothing 0.023 - 0.046$ " (7-14 mm).

5.3 Ensuring motor cooling

Note

In order to ensure sufficient cooling of the motor, the distance (D) between the end of the fan cover and a wall or other fixed objects must always be at least 0.16" (50 mm), irrespective of motor size. See fig. 1.

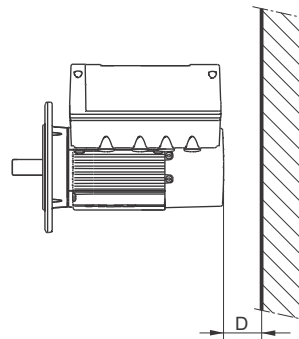

Fig. 1 Minimum distance (D) from the motor to a wall or other fixed objects

5.4 Outdoor installation

When installed outdoors, the motor must be provided with a suitable cover to avoid condensation on the electronic components. See fig. 2.

Note

When fitting a cover to the motor, observe the guideline in section 5.3 Ensuring motor cooling.

The cover must be sufficiently large to ensure that the motor is not exposed to direct sunlight, rain or snow. Grundfos does not supply covers. We therefore recommend that you have a cover built for the specific application. In areas with high air humidity, we recommend that you enable the built-in standstill heating function.

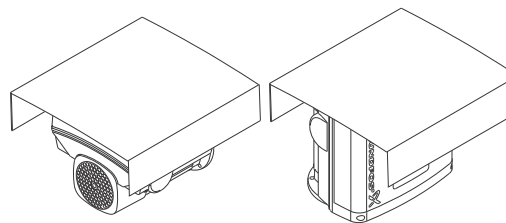

Fig. 2 Examples of covers (not supplied by Grundfos)

5.5 Drain holes

When the motor is installed in moist surroundings or areas with high air humidity, the bottom drain hole should be open.

The enclosure class of the motor will then be lower. The open drain hole helps prevent condensation in the motor as it will make the motor self-venting and allow water and humid air to escape.

The motor has a plugged drain hole on the drive side. The flange can be turned 90° to both sides or 180°.

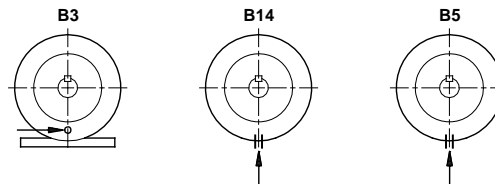

Fig. 3 Drain holes

TM05 5236 3512

TM05 7919 1613

TM02 9037 1604

6. Electrical installation

Carry out the electrical connection according to local regulations. Check that the supply voltage and frequency correspond to the values stated on the nameplate.

Warning

Before making any connections in the terminal box, make sure that the power supply has been switched off for at least 5 minutes. Make sure that the power supply cannot be accidentally switched on.



The motor must be connected to an external all-pole mains switch according to local regulations.

The motor must be earthed and protected against indirect contact in accordance with local regulations.

If the power supply cable is damaged, it must be replaced by the manufacturer, the manufacturer's service partner or a similarly qualified person.

The user or the installer is responsible for the installation of correct earthing and protection according to local regulations. All operations must be carried out by a qualified electrician.

Note

6.1 Protection against electric shock, indirect contact



Warning

The motor must be earthed and protected against indirect contact in accordance with local regulations.

Protective-earth conductors must always have a yellow/green (PE) or yellow/green/blue (PEN) colour marking.

6.1.1 Protection against mains voltage transients

The motor is protected against mains voltage transients in accordance with EN 61800-3.

6.1.2 Motor protection

The motor requires no external motor protection. The motor incorporates thermal protection against slow overloading and blocking.

6.2 Mains supply

6.2.1 Single-phase supply voltage

- 1 x 200-240 V - 10 %/+ 10 %, 60 Hz, PE.

Check that the supply voltage and frequency correspond to the values stated on the nameplate.

The wires in the motor terminal box must be as short as possible. Excepted from this is the separated earth conductor which must be so long that it is the last one to be disconnected in case the cable is inadvertently pulled out of the cable entry.

For maximum backup fuse, see section 20.1 Supply voltage.

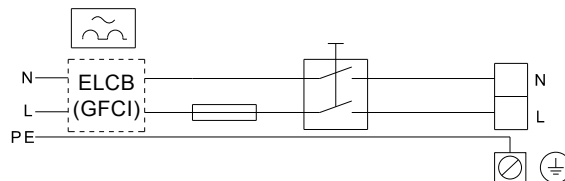

Fig. 4 Example of a mains-connected motor with mains switch, backup fuse and additional protection

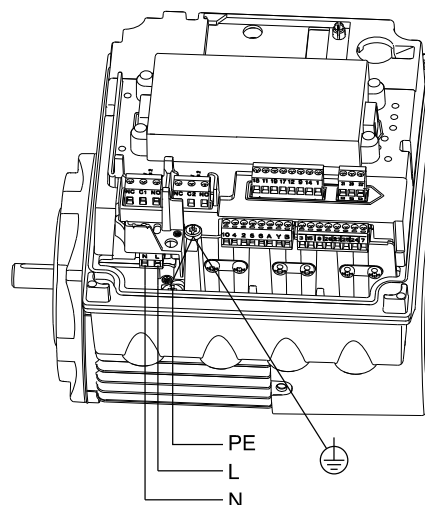

Fig. 5 Mains connection, single-phase motors

TM05 4034 1912

TM05 3494 1512

6.2.2 Three-phase supply voltage

- 3 x 440-480 V - 10 %/+ 10 %, 60 Hz, PE.

Caution

In order to avoid loose connections, ensure that the terminal block for L1, L2 and L3 is pressed home in its socket when the supply cable has been connected.

Note

Corner grounding is not allowed for supply voltages above 3 x 480 V, 60 Hz.

Check that the supply voltage and frequency correspond to the values stated on the nameplate.

The wires in the motor terminal box must be as short as possible. Excepted from this is the separated earth conductor which must be so long that it is the last one to be disconnected in case the cable is inadvertently pulled out of the cable entry.

For maximum backup fuse, see section 21.1 Supply voltage.

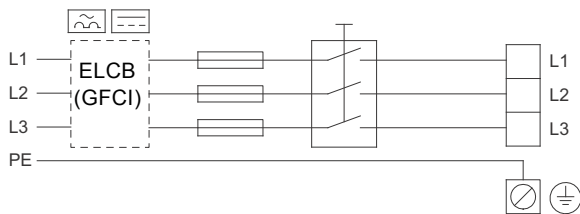

Fig. 6 Example of a mains-connected motor with mains switch, backup fuses and additional protection

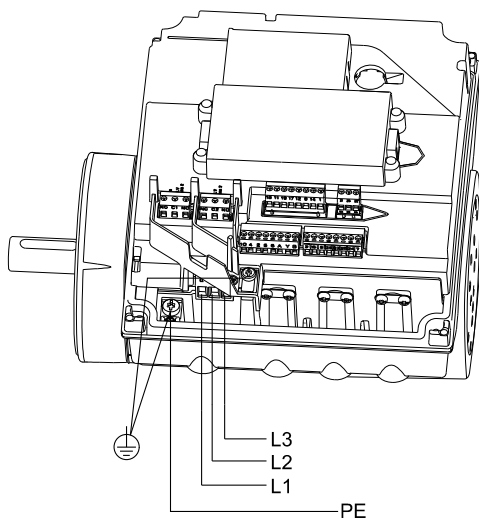

Fig. 7 Mains connection, three-phase motors

TM05 3942 1812

TM05 3495 1512

6.3 Additional protection

6.3.1 Single-phase motors

If the motor is connected to an electric installation where an earth leakage circuit breaker (ELCB) or ground fault circuit interrupter (GFCI) is used as additional protection, this circuit breaker or interrupter must be marked with the following symbol:

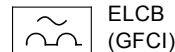

Note

When an earth leakage circuit breaker or ground fault circuit interrupter is selected, the total leakage current of all the electrical equipment in the installation must be taken into account.

The leakage current of the motor can be found in section 20.2 Leakage current.

6.3.2 Three-phase motors

If the motor is connected to an electric installation where an earth leakage circuit breaker (ELCB) or ground fault circuit interrupter (GFCI) is used as additional protection, this circuit breaker or interrupter must be of the following type:

- It must be suitable for handling leakage currents and cutting-in with short pulse-shaped leakage.
- It must trip out when alternating fault currents and fault currents with DC content, i.e. pulsating DC and smooth DC fault currents, occur.

For these motors an earth leakage circuit breaker or ground fault circuit interrupter, type B, must be used.

This circuit breaker or interrupter must be marked with the following symbols:

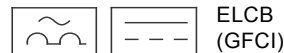

Note

When an earth leakage circuit breaker or ground fault circuit interrupter is selected, the total leakage current of all the electrical equipment in the installation must be taken into account.

The leakage current of the motor can be found in section 21.2 Leakage current.

Protection against phase unbalance

The motor must be connected to a power supply with a quality corresponding to IEC 60146-1-1, class C, to ensure correct motor operation at phase unbalance.

This also ensures long life of the components.

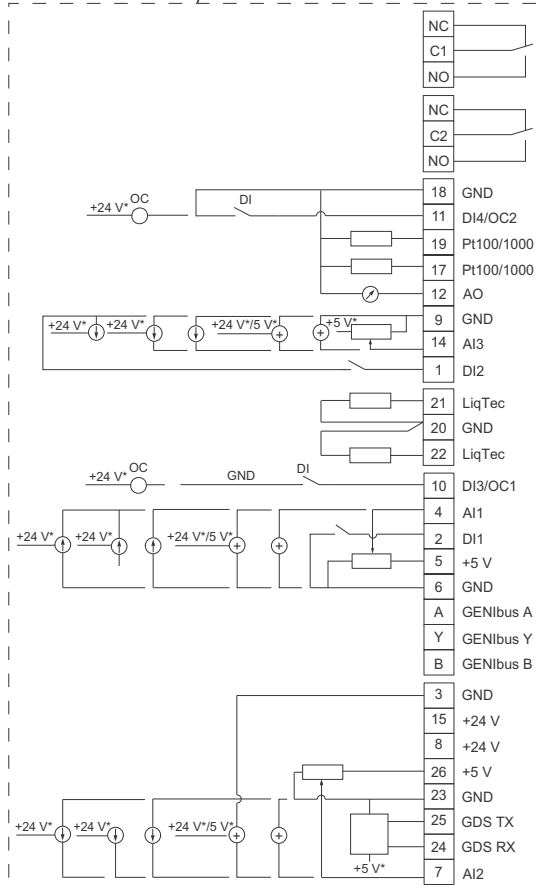
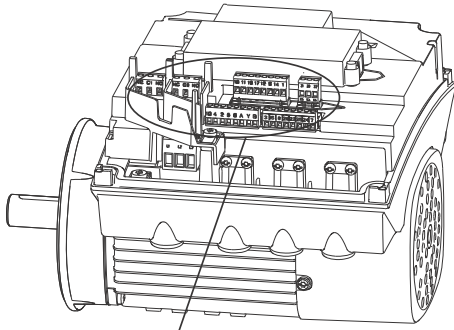

TM05 3509 3512

* If an external supply source is used, there must be a connection to GND.

Fig. 9 Connection terminals, FM 300 (option)

Terminal	Type	Function
NC	Normally closed contact	Signal relay 1 (LIVE or SELV)
C1	Common	
NO	Normally open contact	
NC	Normally closed contact	Signal relay 2 (SELV only)
C2	Common	
NO	Normally open contact	
18	GND	Ground
11	DI4/OC2	Digital input/output, configurable. Open collector: Max. 24 V resistive or inductive.
19	Pt100/1000 input 2	Pt100/1000 sensor input
17	Pt100/1000 input 1	Pt100/1000 sensor input
12	AO	Analog output: 0-20 mA / 4-20 mA / 0-10 V
9	GND	Ground
14	AI3	Analog input: 0-20 mA / 4-20 mA / 0-10 V
1	DI2	Digital input, configurable
21	LiqTec sensor input 1	LiqTec sensor input (white conductor)
20	GND	Ground (brown and black conductors)
22	LiqTec sensor input 2	LiqTec sensor input (blue conductor)
10	DI3/OC1	Digital input/output, configurable. Open collector: Max. 24 V resistive or inductive.
4	AI1	Analog input: 0-20 mA / 4-20 mA / 0.5 - 3.5 V / 0-5 V / 0-10 V
2	DI1	Digital input, configurable
5	+5 V	Supply to potentiometer and sensor
6	GND	Ground
A	GENIbus, A	GENIbus, A (+)
Y	GENIbus, Y	GENIbus, GND
B	GENIbus, B	GENIbus, B (-)
3	GND	Ground
15	+24 V	Supply
8	+24 V	Supply
26	+5 V	Supply to potentiometer and sensor
23	GND	Ground
25	GDS TX	Grundfos Digital Sensor output
24	GDS RX	Grundfos Digital Sensor input
7	AI2	Analog input: 0-20 mA / 4-20 mA / 0.5 - 3.5 V / 0-5 V / 0-10 V

6.5 Signal cables

- Use screened cables with a cross-sectional area of min. AWG 20 (0.5 mm²) and max. AWG 16 (1.5 mm²) for external on/off switch, digital inputs, setpoint and sensor signals.
- Connect the screens of the cables to frame at both ends with good connection. The screens must be as close as possible to the terminals. See fig. 10.

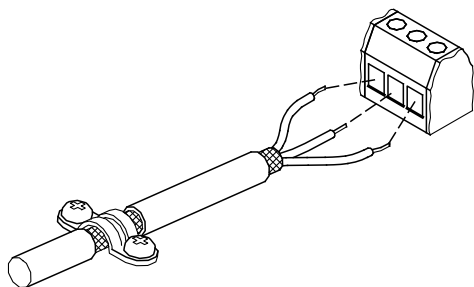

Fig. 10 Stripped cable with screen and wire connections

- Screws for frame connections must always be tightened whether a cable is fitted or not.
- The wires in the motor terminal box must be as short as possible.

6.6 Bus connection cable

6.6.1 New installations

For the bus connection, use a screened 3-core cable with a cross-sectional area of min. AWG 20 (0.5 mm²) and max. AWG 16 (1.5 mm²).

- If the motor is connected to a unit with a cable clamp which is identical to the one on the motor, connect the screen to this cable clamp.
- If the unit has no cable clamp as shown in fig. 11, leave the screen unconnected at this end.

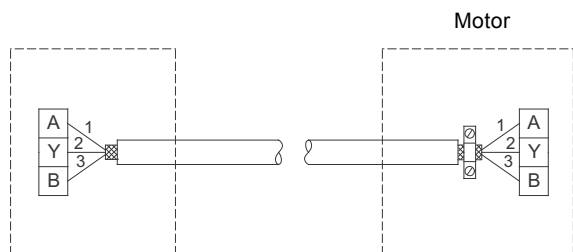

Fig. 11 Connection with screened 3-core cable

6.6.2 Replacing an existing motor

- If a screened 2-core cable is used in the existing installation, connect the cable as shown in fig. 12.

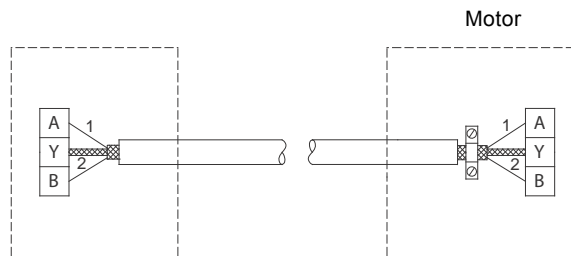

Fig. 12 Connection with screened 2-core cable

- If a screened 3-core cable is used in the existing installation, follow the instructions in section 6.6.1 *New installations*.

7. Operating conditions

7.1 Maximum number of starts and stops

The number of starts and stops via the power supply must not exceed four times per hour.

When switched on via the power supply, the pump will start after approx. 5 seconds.

If a higher number of starts and stops is desired, use the input for external start/stop when starting/stopping the pump.

When started via an external on/off switch, the pump will start immediately.

7.2 Ambient temperature

7.2.1 Ambient temperature during storage and transportation

-22 - +140 °F (-30 - +60 °C).

7.2.2 Ambient temperature during operation

-4 - +122 °F (-20 - +50 °C).

The motor can operate with the rated power output (P2) at 122 °F (50 °C), but continuous operation at higher temperatures will reduce the expected product life. If the motor is to operate at ambient temperatures between 122 and 140 °F (50 and 60 °C), an oversized motor must be selected. Contact Grundfos for further information.

TM02 1325 4402

TM02 8842 0904

TM05 3973 1812

7.3 Installation altitude

Caution

The motor must not be installed more than 6562 ft (2000 m) above sea level.

Installation altitude is the height above sea level of the installation site.

- Motors installed up to 3281 ft (1000 m) above sea level can be loaded 100 %.
- Motors installed more than 3281 ft (1000 m) above sea level must not be fully loaded due to the low density and consequent low cooling effect of the air. See fig. 13.

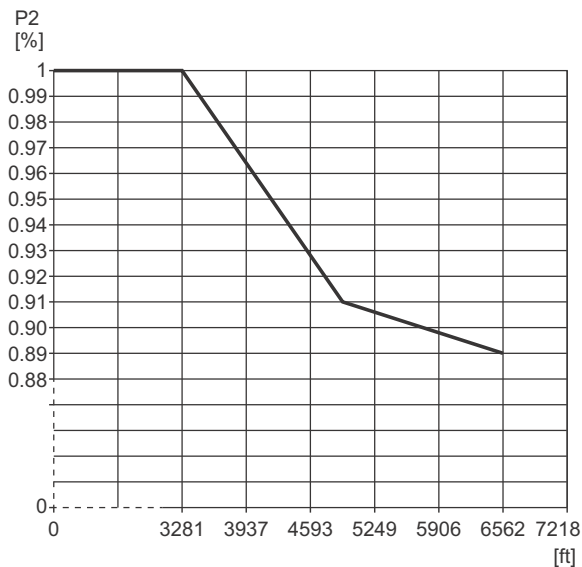

Fig. 13 Derating of motor output power (P2) in relation to altitude above sea level

7.4 Air humidity

Maximum air humidity: 95 %.

If the air humidity is constantly high and above 85 %, one of the drain holes in the drive-end flange should be open. See section 5. *Mechanical installation*.

7.5 Motor cooling

To ensure cooling of motor and electronics, observe the following:

- Position the motor in such a way that adequate cooling is ensured. See section 5.3 *Ensuring motor cooling*.
- The temperature of the cooling air must not exceed 122 °F (50 °C).
- Keep cooling fins and fan blades clean.

8. User interfaces

Warning

The product may be so hot that only the buttons should be touched to avoid burns.

Pump settings can be made by means of the following user interfaces:

- Standard control panel.
See section 9. *Standard control panel*.
- Grundfos GO Remote.
See section 10. *Grundfos GO Remote*.

If the power supply to the pump is switched off, the settings will be stored.

Factory settings

The pumps have been factory-set to constant-curve control mode. See section 9.1.2 *Pump in constant-curve control mode*.

The setpoint value corresponds to maximum pump performance. See data booklet or WebCAPS.

TM05 6400-U.S. 1013

9. Standard control panel

This control panel is fitted as standard on TPE pumps.

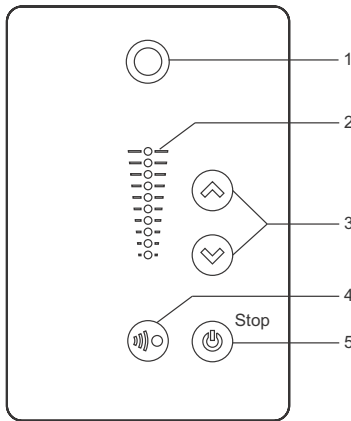

Fig. 14 Standard control panel

Pos.	Symbol	Description
1		Grundfos Eye Shows the operating status of the pump. See section 17. <i>Grundfos Eye</i> for further information.
2	-	Light fields for indication of setpoint.
3		Changes the setpoint.
4		Enables radio communication with the Grundfos GO Remote and other products of the same type.
5		Makes the pump ready for operation/starts and stops the pump. Start: If the button is pressed when the pump is stopped, the pump will only start if no other functions with higher priority have been enabled. See section 16. <i>Priority of settings</i> . Stop: If the button is pressed when the pump is running, the pump will always be stopped. When the pump is stopped via this button, the "Stop" text next to the button will illuminate.

9.1 Setpoint setting

Set the desired setpoint of the pump by pressing or . The light fields on the control panel will indicate the setpoint set.

9.1.1 Pump in differential-pressure control mode

The following example applies to a pump in an application where a pressure sensor gives a feedback to the pump. If the sensor is retrofitted to the pump, it must be set up manually as the pump does not automatically register a connected sensor.

Figure 15 shows that the light fields 5 and 6 are activated, indicating a desired setpoint of 4.3 psi (3 m) with a sensor measuring range from 0 to 8.5 psi (0 to 6 m). The setting range is equal to the sensor measuring range.

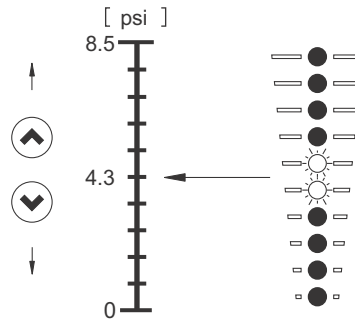

Fig. 15 Setpoint set to 4.3 psi (3 m), differential-pressure control

9.1.2 Pump in constant-curve control mode

In constant-curve control mode, the pump performance will lie between the max. and min. curve of the pump. See fig. 16.

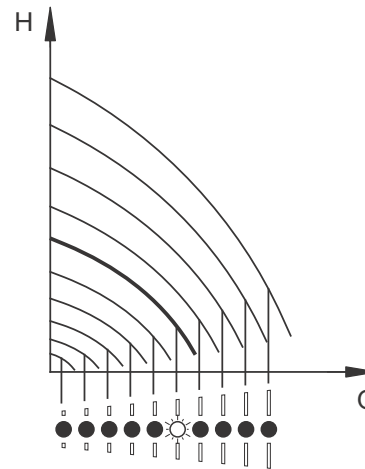

Fig. 16 Pump in constant-curve control mode

Setting to max. curve:

- Press continuously to change over to the max. curve of the pump (top light field flashes). When the top light field is on, press for 3 seconds until the light field starts flashing.
- To change back, press continuously until the desired setpoint is indicated.

Example: Pump set to max. curve.

Figure 17 shows that the top light field is flashing, indicating max. curve.

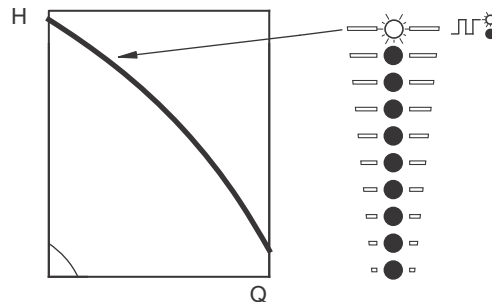

Fig. 17 Max. curve duty

TM05 4848 3512

TM06 0910 1214

TM05 4895 2812

TM05 4896 2812

Setting to min. curve:

- Press continuously to change over to the min. curve of the pump (bottom light field flashes). When the bottom light field is on, press for 3 seconds until the light field starts flashing.
- To change back, press continuously until the desired setpoint is indicated.

Example: Pump set to min. curve.

Figure 18 shows that the bottom light field is flashing, indicating min. curve.

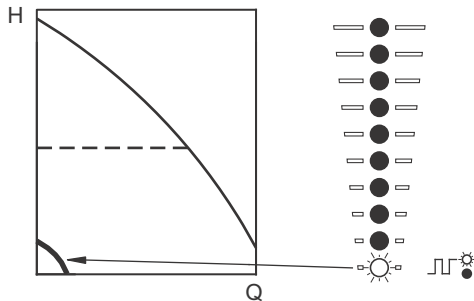

Fig. 18 Min. curve duty

9.1.3 Start/stop of pump

Start the pump by pressing or by continuously pressing until the desired setpoint is indicated.

Stop the pump by pressing . When the pump is stopped, the "Stop" text next to the button will illuminate. The pump can also be stopped by continuously pressing until none of the light fields are on.

If the pump has been stopped by pressing , it can only be given free to operation by pressing again.

If the pump has been stopped by pressing , it can only be restarted by pressing .

The pump can also be stopped with the Grundfos GO Remote or via a digital input set to "External stop". See section 16. *Priority of settings*.

9.1.4 Resetting of fault indications

A fault indication can be reset in one of the following ways:

- Via the digital input if it has been set to "Alarm resetting".
- Briefly press or on the pump. This will not change the setting of the pump.
A fault indication cannot be reset by pressing or if the buttons have been locked.
- Switch off the power supply until the indicator lights are off.
- Switch the external start/stop input off and then on again.
- With the Grundfos GO Remote.

10. Grundfos GO Remote

The pump is designed for wireless radio or infrared communication with the Grundfos GO Remote.

The Grundfos GO Remote enables setting of functions and gives access to status overviews, technical product information and actual operating parameters.

The Grundfos GO Remote offers three different mobile interfaces (MI). See fig. 19.

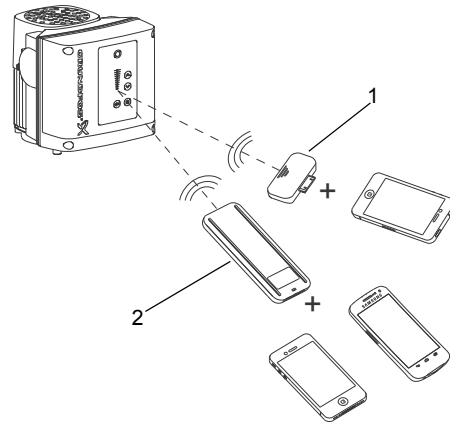

Fig. 19 Grundfos GO Remote communicating with the pump via radio or infrared light

Pos.	Description
1	Grundfos MI 202: Add-on module which can be used in conjunction with Apple iPod touch 4G, iPhone 4G or 4GS.
2	Grundfos MI 204: Add-on module which can be used in conjunction with Apple iPod touch 5G or iPhone 5. Grundfos MI 301: Separate module enabling radio or infrared communication. The module can be used in conjunction with an Android or iOS-based Smartphone with Bluetooth connection.

10.1 Communication

When the Grundfos GO Remote communicates with the pump, the indicator light in the middle of the Grundfos Eye will flash green. See section 17. *Grundfos Eye*.

Communication must be established using one of these communication types:

- radio communication
- infrared communication.

10.1.1 Radio communication

Radio communication can take place at distances up to 30 meters. It is necessary to enable communication by pressing or on the pump control panel.

10.1.2 Infrared communication

When communicating via infrared light, the Grundfos GO Remote must be pointed at the pump control panel.

10.2 Menu overview for Grundfos GO Remote

10.2.1 Main menus

Dashboard
Status
Resulting setpoint
Actual controlled value
Motor speed (rpm, %)
Power consumption
Energy consumption
Acc. flow, specific energy
Operating hours
Motor current
Number of starts
Pt100/1000 input 1
Pt100/1000 input 2
Analog output
Analog input 1
Analog input 2
Analog input 3
Digital input 1
Digital input 2
Digital input 3
Digital input 4
Fitted modules

Settings	Section	Page
Setpoint	11.1 <i>Setpoint</i>	15
Operating mode	11.2 <i>Operating mode</i>	15
Control mode	11.4 <i>Control mode</i>	15
Date and time		
Buttons on product		
Controller	11.11 <i>Controller settings</i>	20
Operating range	11.12 <i>Operating range</i>	21
Ramps	11.15.2 <i>Ramps</i>	24
Pump number	11.16.1 <i>Pump number</i>	24
Radio communication		
Analog input 1		
Analog input 2	11.5 <i>Analog inputs</i>	18
Analog input 3		
Pt100/1000 input 1		
Pt100/1000 input 2	11.6 <i>Pt100/1000 inputs</i>	18
Digital input 1		
Digital input 2	11.7 <i>Digital inputs</i>	19
Digital in/output 3		
Digital in/output 4	11.8 <i>Digital inputs/outputs</i>	19
Predefined setpoint	11.13.2 <i>Predefined setpoints</i>	24
Analog output	11.10 <i>Analog output</i>	20
External setpoint funct.	11.13.1 <i>External setpoint influence</i>	21
Signal relay 1		
Signal relay 2	11.9 <i>Relay outputs</i>	20
Limit 1 exceeded		
Limit 2 exceeded	11.14.1 <i>Limit-exceeded function</i>	24
Standstill heating		
Motor bearing monitoring		
Service		
Reset to factory settings		
Store settings		
Recall settings		
Undo		
Pump name		
Unit configuration		
Alarms and warnings		
Alarm log		
Warning log		
"Reset alarm" button		
Assist		
Assisted pump setup		
Assisted fault advice		
Multi-pump setup		
Product information		
Product information		

11. Description of selected functions

11.1 Setpoint

The setpoint for all control modes can be set in this submenu when the desired control mode has been selected. See section 11.4 *Control mode*.

11.2 Operating mode

Possible operating modes:

- Normal
The pump runs according to the selected control mode.
- Stop
The pump stops.
- Min.
The min. curve mode can be used in periods in which a minimum flow is required.
- Max.
The max. curve mode can be used in periods in which a maximum flow is required.
This operating mode is for instance suitable for systems with hot-water priority.
- Manual
The pump is operating at a manually set speed.
See section 11.3 *Set manual speed*.

The pump can be set to operate according to the max. or min. curve, like an uncontrolled pump. See fig. 20.

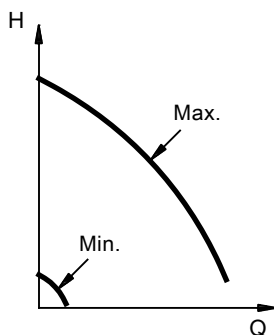

Fig. 20 Max. and min. curves

11.3 Set manual speed

The pump speed can be set in %. When the operating mode has been set to "Manual", the pump will run at the set speed.

11.4 Control mode

Possible control modes:

- Const. pressure (constant pressure)
- Const. temp. (constant temperature)
- Con. diff. press. (constant differential pressure)
- Con. diff. temp. (constant differential temperature)
- Const. flow rate (constant flow rate)
- Const. level (constant level)
- Const. other val. (constant other value)
- Const. curve (constant curve).

Note

The operating mode must be set to "Normal" before a control mode can be enabled.

The setpoint for all control modes can be changed in the "Setpoint" submenu under "Settings" when the desired control mode has been selected.

11.4.1 Constant pressure

The pump maintains a constant discharge pressure, independently of the flow rate. See fig. 21.

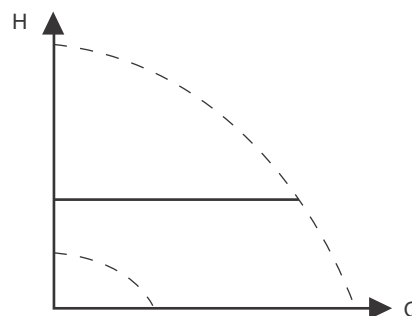

Fig. 21 Constant pressure

This control mode requires an external differential-pressure sensor as shown in the examples below:

Examples

- One external differential-pressure sensor.

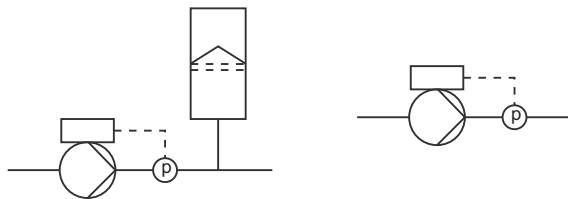

Fig. 22 Constant pressure

TM00 5547 0995

TM05 7901 1613

11.4.2 Constant temperature

This control mode ensures a constant temperature. Constant temperature is a comfort control mode that can be used in domestic hot-water systems to control the flow to maintain a constant temperature in the system. See fig. 23. When this control mode is used, no balancing valves must be installed in the system.

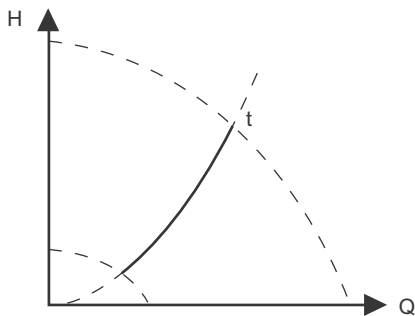

TM05 7900 1613

Fig. 23 Constant temperature

This control mode requires an external temperature sensor as shown in the examples below:

Examples

- One external temperature sensor.

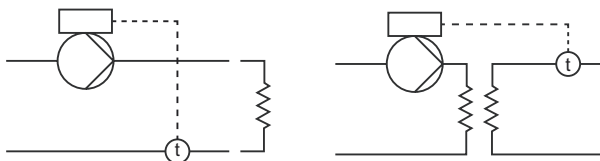
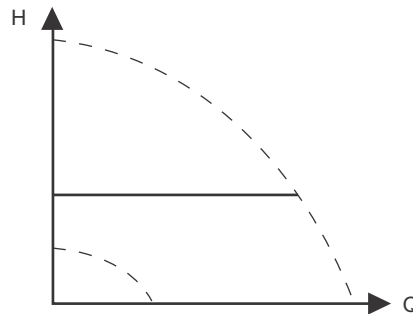

Fig. 24 Constant temperature

11.4.3 Constant differential pressure

The pump maintains a constant differential pressure, independently of the flow in the system. See fig. 25. This control mode is primarily suitable for systems with relatively small pressure losses.



TM05 7901 1613

Fig. 25 Constant differential pressure

This control mode requires either an external differential-pressure sensor or two external pressure sensors as shown in the examples below:

Examples

- One external differential-pressure sensor.

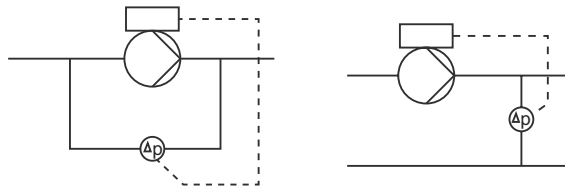

- Two external pressure sensors.

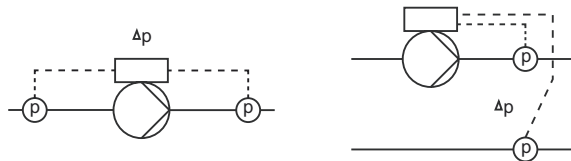
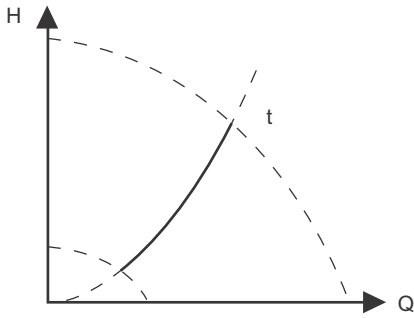

Fig. 26 Constant differential pressure

11.4.4 Constant differential temperature

The pump maintains a constant differential temperature in the system and the pump performance is controlled according to this. See fig. 27.



TM05 7954 1713

Fig. 27 Constant differential temperature

This control mode requires either two external temperature sensors or one external differential-temperature sensor as shown in the examples below:

Examples

- Two external temperature sensors.

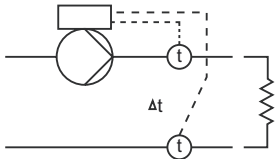

- One external differential-temperature sensor.

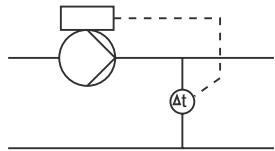
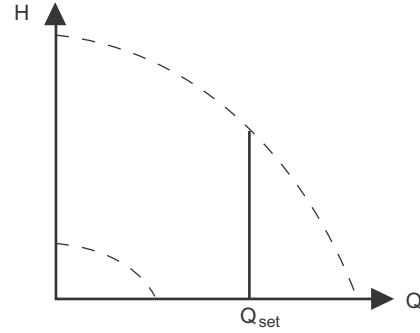

Fig. 28 Constant differential temperature

11.4.5 Constant flow rate

The pump maintains a constant flow in the system, independently of the head. See fig. 29.



TM05 7955 1713

Fig. 29 Constant flow rate

This control mode requires an external flow sensor as shown in the example below:

Example

- One external flow sensor.

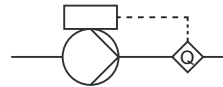
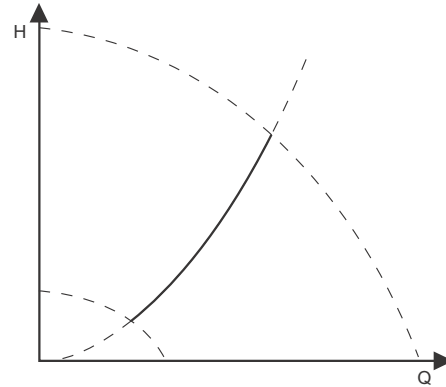

Fig. 30 Constant flow rate

11.4.6 Constant level

The pump maintains a constant level, independently of the flow rate. See fig. 31.



TM05 7941 1613

Fig. 31 Constant level

This control mode requires an external level sensor.

The pump can control the level in a tank in two ways:

- as an emptying function where the pump draws the liquid from the tank.
- as a filling function where the pump pumps the liquid into the tank.

See fig. 32.

The type of level control function depends on the setting of the built-in controller. See section 11.11 *Controller settings*.

Examples

- One external level sensor.
– emptying function.

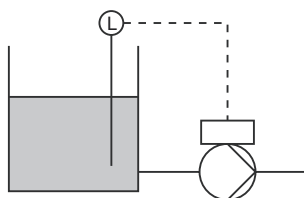

- One external level sensor.
– filling function.

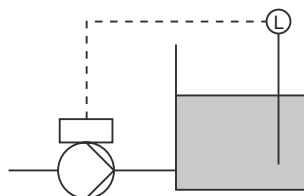

Fig. 32 Constant level

11.4.7 Constant other value

Any other value is kept constant.

11.4.8 Constant curve

The pump can be set to operate according to a constant curve, like an uncontrolled pump. See fig. 33.

The desired speed can be set in % of maximum speed in the range from 25 to 100 % (110 %).

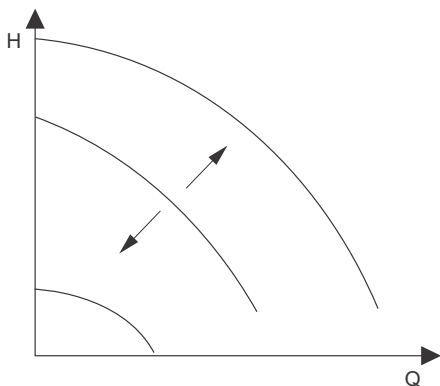

Fig. 33 Constant curve

11.5 Analog inputs

Available inputs depending on the functional module fitted in the pump:

Function (terminal)	FM 300 (advanced)
Analog input 1, setup (4)	•
Analog input 2, setup (7)	•
Analog input 3, setup (14)	•

To set up an analog input, make the settings below.

Function

The analog inputs can be set to these functions:

- Not active
- Feedback sensor
- Ext. setpoint infl.
See section 11.13 *Setpoint influence*.
- Other function.

Measured parameter

Select one of the parameters, i.e. the parameter to be measured in the system by the sensor connected to the actual analog input.

Unit

Available measuring units:

Parameter	Possible units
Pressure	bar, m, kPa, psi, ft
Pump flow	m ³ /h, l/s, yd ³ /h, gpm
Liquid temp.	°C, °F
Other parameter	%

Electrical signal

Select signal type (0.5 - 3.5 V, 0-5 V, 0-10 V, 0-20 mA or 4-20 mA).

Sensor range, min. value

Set the min. value of the connected sensor.

Sensor range, max. value

Set the max. value of the connected sensor.

11.6 Pt100/1000 inputs

Available inputs depending on the functional module fitted in the pump:

Function (terminal)	FM 300 (advanced)
Pt100/1000 input 1, setup (17 and 18)	•
Pt100/1000 input 2, setup (18 and 19)	•

Function

The Pt100/1000 inputs can be set to these functions:

- Not active
- Feedback sensor
- Ext. setpoint infl.
See section 11.13 *Setpoint influence*.
- Other function.

Measured parameter

Select one of the parameters, i.e. the parameter to be measured in the system.

TM05 7957 1713

11.7 Digital inputs

Available inputs depending on the functional module fitted in the pump:

Function (terminal)	FM 300 (advanced)
Digital input 1, setup (2 and 6)	•
Digital input 2, setup (1 and 9)	•

To set up a digital input, make the settings below.

Function

Select one of these functions:

- Not active
When set to "Not active", the input has no function.
- External stop
When the input is deactivated (open circuit), the pump will stop.
- Min. (min. speed)
When the input is activated, the pump will run at the set min. speed.
- Max. (max. speed)
When the input is activated, the pump will run at the set max. speed.
- External fault
When the input is activated, a timer will be started. If the input is activated for more than 5 seconds, the pump will be stopped and a fault will be indicated.
- Alarm resetting
When the input is activated, a possible fault indication will be reset.
- Dry running
When this function has been selected, lack of inlet pressure or water shortage can be detected.
When lack of inlet pressure or water shortage (dry running) is detected, the pump will be stopped. The pump cannot restart as long as the input is activated.
This requires the use of an accessory, such as these:
 - a pressure switch installed on the suction side of the pump
 - a float switch installed on the suction side of the pump.
- Accumulated flow
When this function has been selected, the accumulated flow can be registered. This requires the use of a flowmeter which can give a feedback signal as a pulse per defined flow of water.
See section 11.15.1 *Pulse flowmeter setup*.
- Predefined setpoint digit 1 (applies only to digital input 2).
When digital inputs are set to predefined setpoint, the pump will operate according to a setpoint based on the combination of the activated digital inputs.
See section 11.13.2 *Predefined setpoints*.

The priority of the selected functions in relation to each other appears from section 16. *Priority of settings*. A stop command will always have the highest priority.

11.8 Digital inputs/outputs

Available inputs/outputs depending on the functional module fitted in the pump:

Function (terminal)	FM 300 (advanced)
Digital input/output 3, setup (10 and 16)	•
Digital input/output 4, setup (11 and 18)	•

To set up a digital input/output, make the settings below.

Mode

The digital input/output 3 and 4 can be set to act as digital input or digital output:

- Digital input
- Digital output.

Function

The digital input/output 3 and 4 can be set to these functions:

Possible functions, digital input/output 3

Function if input	Function if output
• Not active	• Not active
• External stop	• Ready
• Min.	• Alarm
• Max.	• Operation
• External fault	• Pump running
• Alarm resetting	• Warning
• Dry running	• Limit 1 exceeded
• Accumulated flow	• Limit 2 exceeded
• Predefined setpoint digit 2	

Possible functions, digital input/output 4

Function if input	Function if output
• Not active	• Not active
• External stop	• Ready
• Min.	• Alarm
• Max.	• Operation
• External fault	• Pump running
• Alarm resetting	• Warning
• Dry running	• Limit 1 exceeded
• Accumulated flow	• Limit 2 exceeded
• Predefined setpoint digit 3	

11.9 Relay outputs

Function (terminal)	FM 300 (advanced)
Relay output 1 (NC, C1, NO)	•
Relay output 2 (NC, C2, NO)	•

The pump incorporates two signal relays for potential-free signalling. See section 18. *Signal relays* for further information. The signal relays can be configured to be activated by one of the following incidents:

- Ready
- Operation
- Alarm
- Warning
- Limit 1 exceeded
- Limit 2 exceeded
- Pump running
- Control of external fan
- Not active.

11.10 Analog output

Whether the analog output is available or not, depends on the functional module fitted in the pump:

Function (terminal)	FM 300 (advanced)
Analog output	•

To set up the analog output, make the settings below.

Output signal

- 0-10 V
- 0-20 mA
- 4-20 mA.

Function of analog output

- Actual speed
- Actual value
- Resulting setpoint
- Motor load
- Motor current
- Limit 1 exceeded
- Limit 2 exceeded
- Flow rate.

11.11 Controller settings

The pumps have a factory default setting of gain (K_p) and integral time (T_i).

However, if the factory setting is not the optimum setting, the gain and the integral time can be changed:

- Set the gain (K_p) within the range from 0.1 to 20.
- Set the integral-action time (T_i) within the range from 0.1 to 3600 s.
If 3600 s is selected, the controller will function as a P controller.

Furthermore, the controller can be set to inverse control. This means that if the setpoint is increased, the speed will be reduced. In the case of inverse control, the gain (K_p) must be set within the range from -0.1 to -20.

Guidelines for setting of PI controller

The tables below show the recommended controller settings:

Differential-pressure control	K_p	T_i
	0.5	0.5
	0.5	L1 < 16.4 ft (5 m): 0.5 L1 > 16.4 ft (5 m): 3 L1 > 32.8 ft (10 m): 5

L1 = Distance ft (m) between pump and sensor.

Temperature control	K_p		T_i
	Heating system ¹⁾	Cooling system ²⁾	
	0.5	-0.5	10 + 5L2
	0.5	-0.5	30 + 5L2

¹⁾ In heating systems, an increase in pump performance will result in a rise in temperature at the sensor.

²⁾ In cooling systems, an increase in pump performance will result in a drop in temperature at the sensor.

L2 = Distance ft (m) between heat exchanger and sensor.

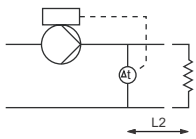
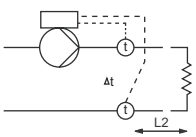
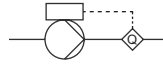
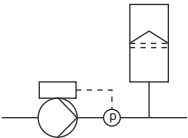
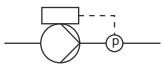
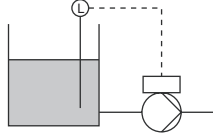
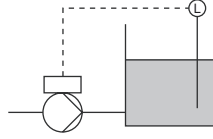
Differential-temperature control	K_p	T_i
	-0.5	10 + 5L2
		
L2 = Distance ft (m) between heat exchanger and sensor.		
Flow control	K_p	T_i
	0.5	0.5
Constant-pressure control	K_p	T_i
	0.5	0.5
	0.1	0.5
Level control	K_p	T_i
	-2.5	100
	2.5	100

General rules of thumb

If the controller is too slow-reacting, increase K_p .
 If the controller is hunting or unstable, dampen the system by reducing K_p or increasing T_i .

11.12 Operating range

Set the operating range as follows:

- Set the min. speed within the range from fixed min. speed to user-set max. speed.
- Set the max. speed within the range from user-set min. speed to fixed max. speed.

The range between the user-set min. and max. speeds is the operating range. See fig. 34.

Note *Speeds below 25 % may result in noise from the shaft seal.*

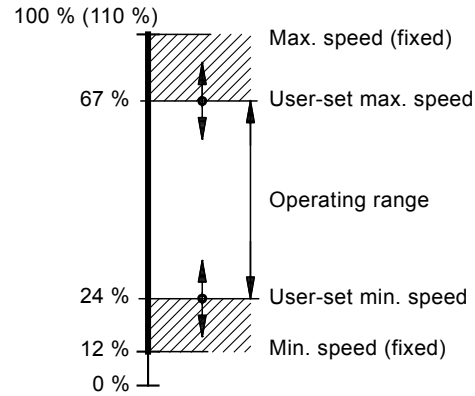

Fig. 34 Example of min. and max. settings

11.13 Setpoint influence

11.13.1 External setpoint influence

It is possible to influence the setpoint by an external signal, either via one of the analog inputs or, if an advanced functional module is fitted, via one of the Pt100/1000 inputs.

Note *Before the "Digital inputs" can be enabled, one of the analog inputs or Pt100/1000 inputs must be set to "External setpoint function".*

See sections 11.5 Analog inputs and 11.6 Pt100/1000 inputs.

If more than one input has been set up for setpoint influence, the function will select the analog input with the lowest number, for example "Analog input 2", and ignore the other inputs, for example "Analog input 3" or "Pt100/1000 input 1".

TM00 6785 5095

Example

See fig. 35.

At a lower sensor value of 0 psi, a set setpoint of 29 psi and an external setpoint of 60 %, the actual setpoint is $0.60 \times (29 - 0) + 0 = 17.4$ psi.

Actual setpoint = actual input signal x (setpoint - lower value) + lower value.

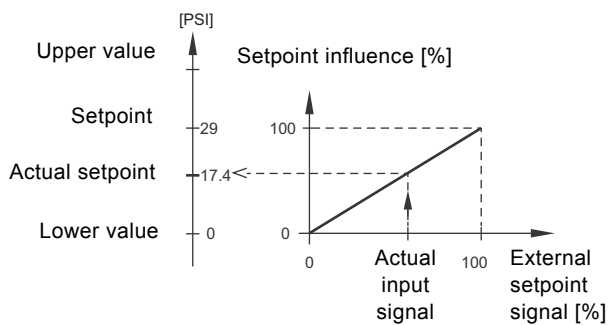

TM06 0854 1014

Fig. 35 Example of setpoint influence

Types of setpoint influence

- Not active
- Linear function
- Linear with Stop
- Linear with Min.
- Inverse function
- Inverse with Stop
- Inverse with Min.
- Influence table
- Influence table with Stop at Min.
- Influence table with Stop at Max.

These functions can be selected:

- Not active
When set to "Not active", the setpoint will not be influenced from any external function.
- Linear function
The setpoint is influenced linearly from 0 to 100 %. See fig. 36.

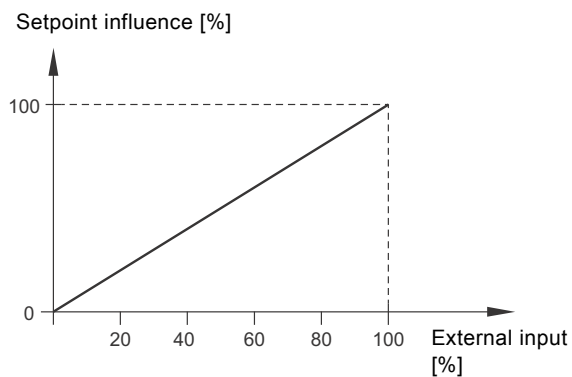

TM05 6280 4612

Fig. 36 Linear function

- "Linear with Stop" and "Linear with Min."

– Linear with Stop

In the input signal range from 20 to 100 %, the setpoint is influenced linearly.

If the input signal is below 10 %, the pump will change to operating mode "Stop".

If the input signal is increased above 15 %, the operating mode will be changed back to "Normal".

See fig. 37.

– Linear with Min.

In the input signal range from 20 to 100 %, the setpoint is influenced linearly.

If the input signal is below 10 %, the pump will change to operating mode "Min."

If the input signal is increased above 15 %, the operating mode will be changed back to "Normal".

See fig. 37.

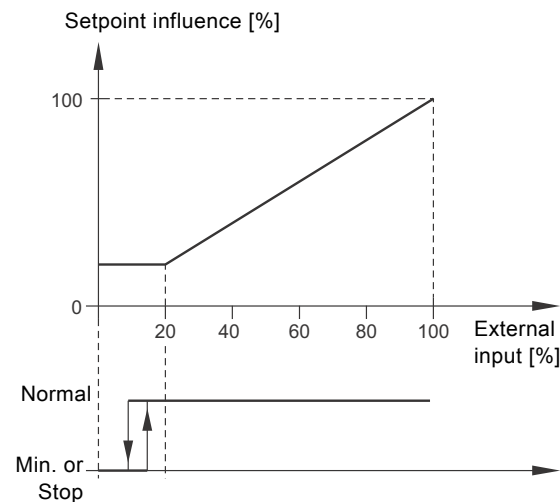

TM05 6281 4612

Fig. 37 "Linear with Stop" and "Linear with Min."

- Inverse function
The setpoint is influenced inversely from 0 to 100 %. See fig. 38.

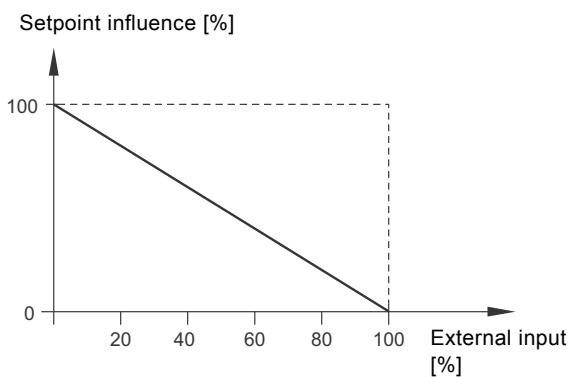

TM05 6283 4612

Fig. 38 Inverse function

- "Inverse with Stop" and "Inverse with Min."
 - Inverse with Stop
 In the input signal range from 0 to 80 %, the setpoint is influenced inversely.
 If the input signal is above 90 %, the pump will change to operating mode "Stop".
 If the input signal is reduced below 85 %, the operating mode will be changed back to "Normal".
 See fig. 39.
 - Inverse with Min.
 In the input signal range from 0 to 80 %, the setpoint is influenced inversely.
 If the input signal is above 90 %, the pump will change to operating mode "Min."
 If the input signal is reduced below 85 %, the operating mode will be changed back to "Normal".
 See fig. 39.

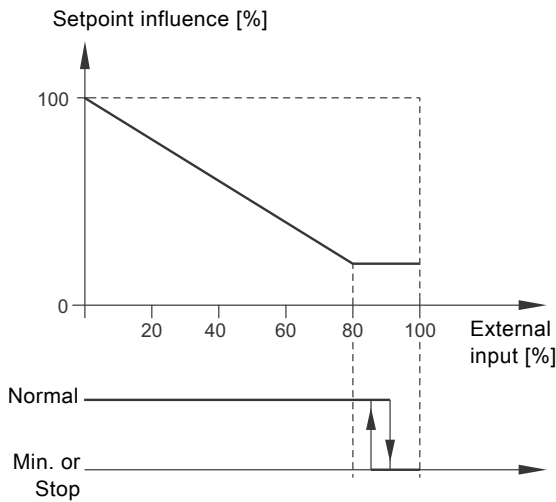

Fig. 39 "Inverse with Stop" and "Inverse with Min."

- Influence table
 The setpoint is influenced by a curve made out of two to eight points. There will be a straight line between the points and a horizontal line before the first point and after the last point.

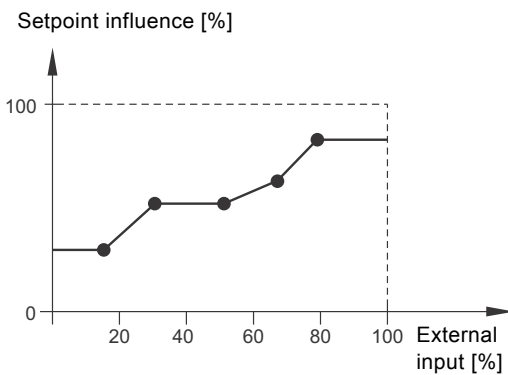

Fig. 40 Influence table

- Influence table with Stop at Min.
 The setpoint is influenced by a curve made out of two to eight points. There will be a straight line between the points and a horizontal line before the first point and after the last point.
 If the input signal is below 10 %, the pump will change to operating mode "Stop".
 If the input signal is increased above 15 %, the operating mode will be changed back to "Normal".
 See fig. 41.

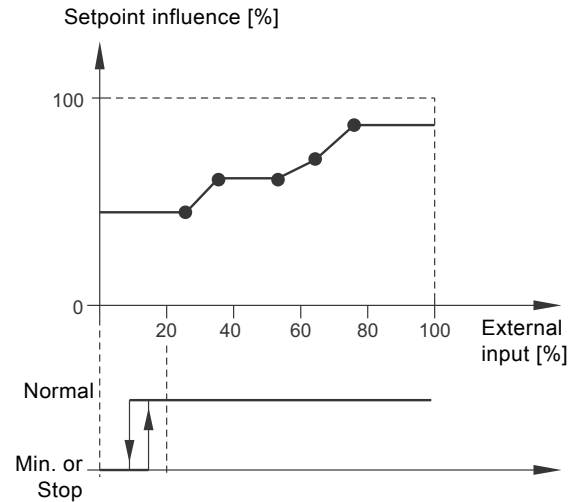

Fig. 41 Influence table with Stop at Min.

- Influence table with Stop at Max.
 The setpoint is influenced by a curve made out of two to eight points. There will be a straight line between the points and a horizontal line before the first point and after the last point.
 If the input signal is above 90 %, the pump will change to operating mode "Min."
 If the input signal is reduced below 85 %, the operating mode will be changed back to "Normal".
 See fig. 42.

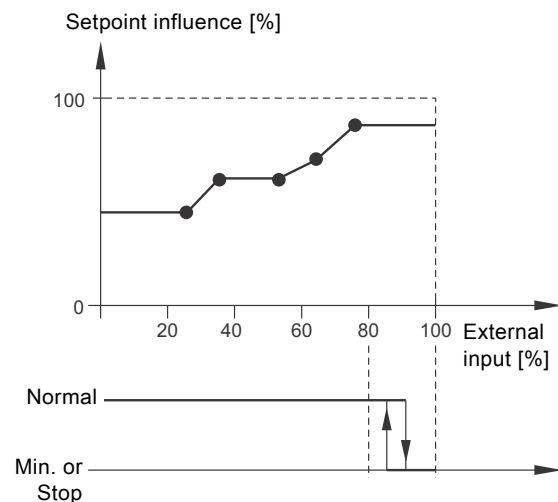

Fig. 42 Influence table with Stop at Max.

TM05 6285 4612

TM05 6283 4612

TM05 6284 4612

TM05 6286 4612

11.13.2 Predefined setpoints

Seven predefined setpoints can be set and activated by combining the input signals to digital inputs 2, 3 and 4 as shown in the table below.

Digital inputs			Setpoint
2	3	4	
0	0	0	Normal setpoint
1	0	0	Predefined setpoint 1
0	1	0	Predefined setpoint 2
1	1	0	Predefined setpoint 3
0	0	1	Predefined setpoint 4
1	0	1	Predefined setpoint 5
0	1	1	Predefined setpoint 6
1	1	1	Predefined setpoint 7

11.14 Monitoring functions

11.14.1 Limit-exceeded function

This function can monitor set limits of analog values. It will react if the values exceed the limits. Each limit can be set as a maximum or minimum value. For each of the monitored values, a warning limit and an alarm limit must be defined.

The function makes it possible to monitor two different locations in a pump system at the same time. For instance the pressure at a consumer and the pump discharge pressure. This ensures that the discharge pressure does not reach a critical value.

If the value exceeds the warning limit, a warning is given. If the value exceeds the alarm limit, the pumps will be stopped.

A delay can be set between the detection of an exceeded limit and the activation of a warning or an alarm. A delay can also be set for resetting a warning or an alarm.

A warning can be reset automatically or manually.

It is possible to set whether the system is to restart automatically after an alarm, or if the alarm must be reset manually. Restarting can be delayed by an adjustable time. It is also possible to set a start-up delay ensuring that the system reaches a steady state before the function becomes active.

11.15 Special functions

11.15.1 Pulse flowmeter setup

An external pulse flowmeter can be connected to one of the digital inputs in order to register the actual and accumulated flows. Based on this, the specific energy (kWh/m³) can also be calculated.

To enable a pulse flowmeter, one of the digital-input functions must be set to "Accumulated flow" and the pumped volume per pulse must be set. See section *11.7 Digital inputs*.

11.15.2 Ramps

The setting of ramps is only relevant in the case of constant-curve operation.

The ramps determine how quickly the motor can accelerate and decelerate, respectively, during start/stop or setpoint changes.

The following can be set:

- acceleration time, 0.1 to 300 s
- deceleration time, 0.1 to 300 s.

The times apply to the acceleration from stop to rated speed and the deceleration from rated speed to stop, respectively.

At short deceleration times, the deceleration of the motor may depend on load and inertia as there is no possibility of actively braking the motor.

If the power supply is switched off, the deceleration of the motor will only depend on load and inertia.

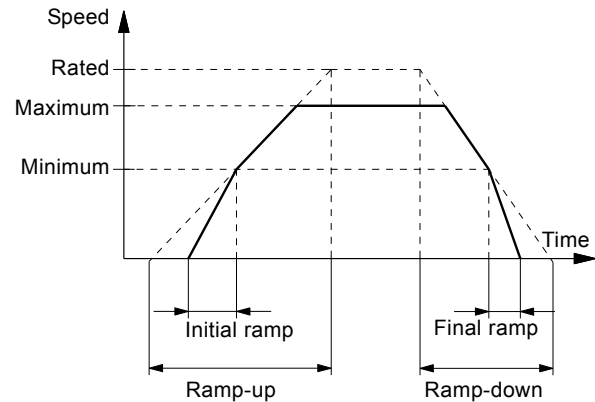

Fig. 43 Ramp-up and ramp-down

11.16 Communication

11.16.1 Pump number

A unique number can be allocated to the pump. This makes it possible to distinguish between pumps in connection with bus communication.

11.17 General settings

11.17.1 Language

A number of languages are available.

Measuring units are automatically changed according to selected language.

TM03 9439 0908

12. Assist

12.1 Setup of multi-pump system

The multi-pump function enables the control of pumps connected in parallel pumps without the use of external controllers.

The pumps in a multi-pump system communicate with each other via the wireless GENlair connection or the wired GENI connection.

A multi-pump system is set up via a selected pump, i.e. the master pump (first selected pump). All Grundfos pumps with a wireless GENlair connection can be connected to the multi-pump system.

The multi-pump functions are described in the following sections.

12.1.1 Alternating operation

Only one pump is operating at a time.

The change from one pump to the other depends on time or energy. If a pump fails, the other pump will take over automatically.

Pump system:

- Two pumps connected in parallel.
The pumps must be of the same type and size. Each pump requires a non-return valve in series with the pump.

12.1.2 Back-up operation

One pump is operating continuously. The back-up pump is operated at intervals to prevent seizing up. If the duty pump stops due to a fault, the back-up pump will start automatically.

Pump system:

- Two pumps connected in parallel.
The pumps must be of the same type and size. Each pump requires a non-return valve in series with the pump.

12.1.3 Cascade operation

Cascade operation ensures that the pump performance is automatically adapted to the consumption by switching pumps on or off. The system thus runs as energy-efficiently as possible with a constant pressure and a limited number of pumps.

All pumps in operation will run at equal speed. Pump changeover is automatic and depends on energy, operating hours and fault.

Pump system:

- Two to four pumps connected in parallel.
The pumps must be of the same type and size. Each pump requires a non-return valve in series with the pump.

The control mode must be set to "Const. pressure", "Con. diff. press." or "Const. curve".

13. Selection of control mode

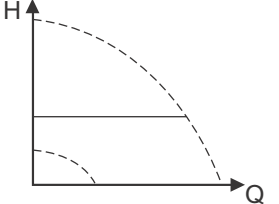
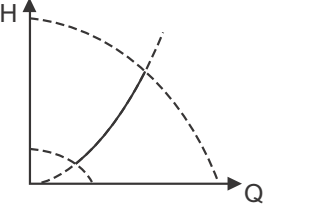
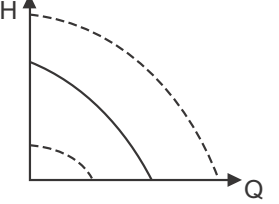
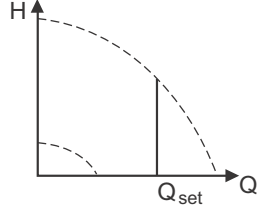
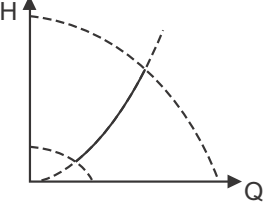
System application	Select this control mode
<p>In systems with relatively small pressure losses in the distribution pipes.</p> <ul style="list-style-type: none"> Two-pipe heating systems with thermostatic valves <ul style="list-style-type: none"> – dimensioned for natural circulation – with small pressure losses in those parts of the system through which the total quantity of water flows (for example boiler, heat exchanger and distribution pipe up to the first branching) or – modified to a high differential temperature between flow pipe and return pipe (for example district heating). Underfloor heating systems with thermostatic valves. One-pipe heating systems with thermostatic valves or pipe balancing valves. Primary circuit pumps in systems with small pressure losses in the primary circuit. 	<p>Constant differential pressure</p> 
<p>In systems with a fixed system characteristic.</p> <p>Examples:</p> <ul style="list-style-type: none"> one-pipe heating systems boiler shunts systems with three-way valves domestic hot-water circulation. 	<p>Constant temperature and constant differential temperature</p> 
<p>If an external controller is installed, the pump is able to change from one constant curve to another, depending on the value of the external signal.</p> <p>The pump can also be set to operate according to the max. or min. curve, like an uncontrolled pump:</p> <ul style="list-style-type: none"> The max. curve mode can be used in periods in which a maximum flow is required. This operating mode is for instance suitable for systems with hot-water priority. The min. curve mode can be used in periods in which a minimum flow is required. 	<p>Constant curve</p> 
<p>In systems requiring a constant flow, independently of pressure drop.</p> <p>Examples:</p> <ul style="list-style-type: none"> chillers for air-conditioning heating surfaces cooling surfaces. 	<p>Constant flow rate</p> 
<p>In systems requiring a constant tank level, independently of the flow rate.</p> <p>Examples:</p> <ul style="list-style-type: none"> process water tanks boiler condensate tanks. 	<p>Constant level</p> 
<p>In systems with pumps operating in parallel.</p> <p>The multi-pump function enables the control of pumps connected in parallel (two to four pumps) without the use of external controllers. The pumps in a multi-pump system communicate with each other via the wireless GENIair connection or the wired GENI connection.</p>	<p>"Assist" menu "Setup of multi-pump system"</p>

14. Changing the position of the control panel

It is possible to turn the control panel 180°. Follow the instructions below.

1. Loosen the four screws (T25) holding the terminal box cover.

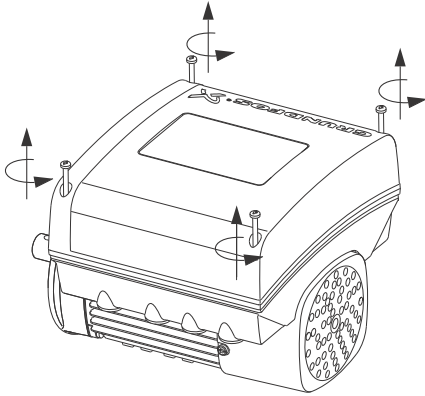

Fig. 44 Loosening the screws

2. Remove the terminal box cover.

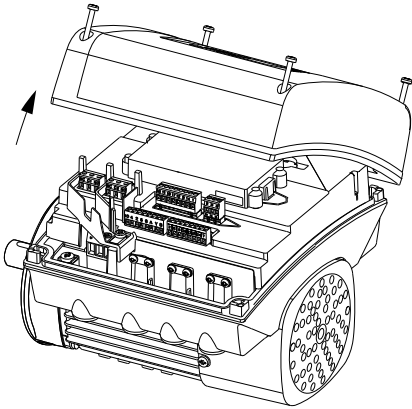

Fig. 45 Removing the terminal box cover

3. Press and hold in the two locking tabs (pos. A) while gently lifting the plastic cover (pos. B).

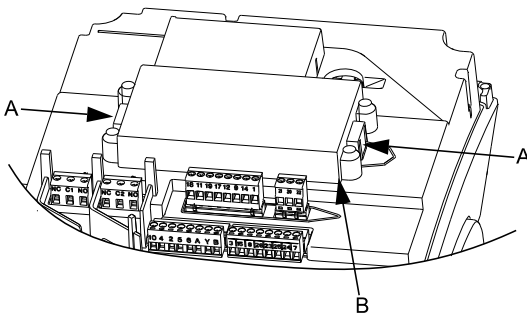

Fig. 46 Lifting the plastic cover

4. Turn the plastic cover 180°.

Note Do not twist the cable more than 90°.

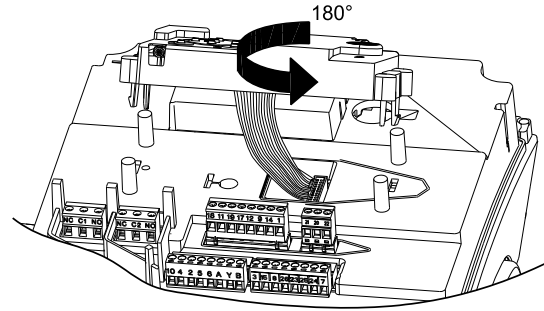

Fig. 47 Turning the plastic cover

5. Re-position the plastic cover correctly on the four rubber pins (pos. C). Make sure that the locking tabs (pos. A) are placed correctly.

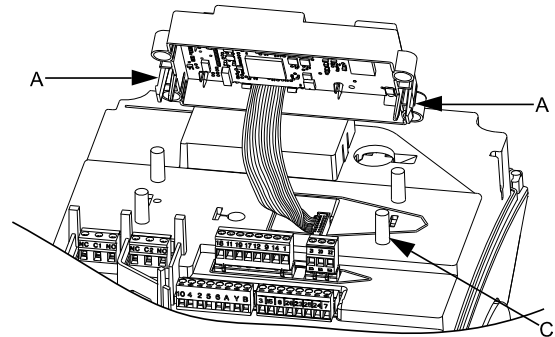

Fig. 48 Re-positioning the plastic cover

6. Fit the terminal box cover, and make sure that it is also turned 180° so that the buttons on the control panel are aligned with the buttons on the plastic cover. Tighten the four screws (T25) with 3.7 lb-ft (5 Nm).

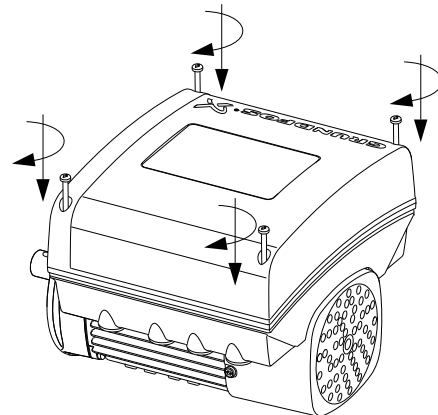

Fig. 49 Fitting the terminal box cover

TM05 5351 3612

TM05 5352 3612

TM05 5353 3612

TM05 5354 3612

TM05 5355 3612

TM05 5356 3612

15. Bus signal

The motor enables serial communication via an RS-485 input. The communication is carried out according to the Grundfos GENIbus protocol and enables connection to a building management system or another external control system.

Via a bus signal, it is possible to remote-set motor operating parameters, such as setpoint and operating mode. At the same time, the motor can, via the bus, provide status information about important parameters, such as actual value of control parameter, input power and fault indications.

Contact Grundfos for further information.

Note

If a bus signal is used, the number of settings available via the Grundfos GO Remote will be reduced.

16. Priority of settings

The motor can always be set to operation at max. speed or to stop with the Grundfos GO Remote.

If two or more functions are enabled at the same time, the motor will operate according to the function with the highest priority.

Example: If, via the digital input, the motor has been set to max. speed, the motor control panel or the Grundfos GO Remote can only set the motor to "Manual" or "Stop".

The priority of the settings appears from the table below:

Priority	Start/stop button	Control panel on motor or Grundfos GO Remote	Digital input	Bus communication
1	Stop			
2		Stop*		
3		Manual		
4		Max. speed*		
5			Stop	
6				Stop
7				Max. speed
8				Min. speed
9				Start
10			Max. speed	
11		Min. speed		
12			Min. speed	
13			Start	
14		Start		

* If the bus communication is interrupted, the motor will resume its previous operating mode, for example "Stop", selected on the motor control panel or with the Grundfos GO Remote.

17. Grundfos Eye

The operating condition of the pump is indicated by the Grundfos Eye on the control panel. See fig. 50, pos. A.

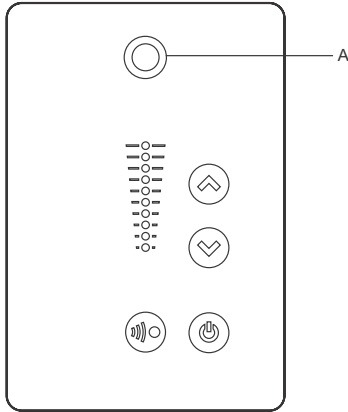

TM05 5993 4312

Fig. 50 Grundfos Eye





























































Grundfos Eye	Indication	Description
	No lights on.	Power off. Motor not running.
	Two opposite green indicator lights rotating in the direction of rotation of the motor when seen from the non-drive end.	Power on. Motor running.
	Two opposite green indicator lights permanently on.	Power on. Motor not running.
	One yellow indicator light rotating in the direction of rotation of the motor when seen from the non-drive end.	Warning. Motor running.
	One yellow indicator light permanently on.	Warning. Motor stopped.
	Two opposite red indicator lights flashing simultaneously.	Alarm. Motor stopped.
	The green indicator light in the middle flashes quickly four times.	Remote control with the Grundfos GO Remote via radio. The motor is trying to communicate with the Grundfos GO Remote. The motor in question is highlighted in the Grundfos GO Remote display to inform the user of the location of the motor.
	The green indicator light in the middle flashes continuously.	When the motor in question is selected in the Grundfos GO Remote menu, the green indicator light in the middle will flash continuously. Press on the motor control panel to allow remote control and data exchange via the Grundfos GO Remote.
	The green indicator light in the middle is permanently on.	Remote control with the Grundfos GO Remote via radio. The motor is communicating with the Grundfos GO Remote via radio connection.
	The green indicator light in the middle flashes quickly while the Grundfos Go Remote is exchanging data with the motor. It will take a few seconds.	Remote control with the Grundfos GO Remote via infrared light. The motor is receiving data from the Grundfos GO Remote via infrared communication.

18. Signal relays

The motor has two outputs for potential-free signals via two internal relays.

The signal outputs can be set to "Operation", "Pump running", "Ready", "Alarm" and "Warning".

The functions of the two signal relays appear from the table below:

Description	Grundfos Eye	Contact position for signal relays when activated					Operating mode
		Operation	Pump running	Ready	Alarm	Warning	
Power off.	 Off						-
Pump running in "Normal" mode	 Green, rotating						Normal, Min. or Max.
Pump running in "Manual" mode.	 Green, rotating						Manual
Pump in operating mode "Stop".	 Green, steady						Stop
Warning, but the pump is running.	 Yellow, rotating						Normal, Min. or Max.
Warning, but the pump is running in "Manual" mode.	 Yellow, rotating						Manual
Warning, but the pump was stopped via "Stop" command.	 Yellow, steady						Stop
Alarm, but the pump is running.	 Red, rotating						Normal, Min. or Max.
Alarm, but the pump is running in "Manual" mode.	 Red, rotating						Manual
Pump stopped due to an alarm.	 Red, flashing						Stop

19. Megging

Caution

Megging of an installation incorporating MLE motors is not allowed, as the built-in electronics may be damaged.

20. Technical data, single-phase motors

20.1 Supply voltage

- 1 x 200-240 V - 10 %/+ 10 %, 60 Hz, PE.

Check that the supply voltage and frequency correspond to the values stated on the nameplate.

Recommended fuse size

Motor size [hp (kW)]	Min. [A]	Max. [A]
0.25 to 1.00 (0.12 to 0.75)	6	10
1.50 to 2.00 (1.1 to 1.5)	10	16

Standard as well as quick-blow or slow-blow fuses may be used.

20.2 Leakage current

Earth leakage current < 3.5 mA (AC supply).

Earth leakage current < 10 mA (DC supply).

The leakage currents are measured in accordance with EN 61800-5-1:2007.

21. Technical data, three-phase motors

21.1 Supply voltage

- 3 x 440-480 V - 10 %/+ 10 %, 60 Hz, PE.

Check that the supply voltage and frequency correspond to the values stated on the nameplate.

Recommended fuse size

Motor size [hp (kW)]	Min. [A]	Max. [A]
0.25 to 1.50 (0.12 to 1.1)	6	6
2.00 to 3.00 (1.5 to 2.2)	6	10

Standard as well as quick-blow or slow-blow fuses may be used.

21.2 Leakage current

Motor size [hp (kW)]	Leakage current [mA]
1.00 to 3.00 (0.75 to 2.2) (supply voltage < 400 V)	< 3.5
1.00 to 3.00 (0.75 to 2.2) (supply voltage > 400 V)	< 5

The leakage currents are measured in accordance with EN 61800-5-1:2007.

22. Inputs/outputs

Ground reference (GND)

All voltages refer to GND.

All currents return to GND.

Absolute maximum voltage and current limits

Exceeding the following electrical limits may result in severely reduced operating reliability and motor life:

Relay 1:

Maximum contact load: 250 VAC, 2 A or 30 VDC, 2 A.

Relay 2:

Maximum contact load: 30 VDC, 2 A.

GENI terminals: -5.5 to 9.0 VDC or < 25 mADC.

Other input/output terminals: -0.5 to 26 VDC or < 15 mADC.

Digital inputs (DI)

Internal pull-up current > 10 mA at $V_i = 0$ VDC.

Internal pull-up to 5 VDC (currentless for $V_i > 5$ VDC).

Certain low logic level: $V_i < 1.5$ VDC.

Certain high logic level: $V_i > 3.0$ VDC.

Hysteresis: No.

Screened cable: 20-16 AWG (0.5 - 1.5 mm²).

Maximum cable length: 1640 ft (500 m).

Open-collector digital outputs (OC)

Current sinking capability: 75 mADC, no current sourcing.

Load types: Resistive or/and inductive.

Low-state output voltage at 75 mADC: Max. 1.2 VDC.

Low-state output voltage at 10 mADC: Max. 0.6 VDC.

Overcurrent protection: Yes.

Screened cable: 20-16 AWG (0.5 - 1.5 mm²).

Maximum cable length: 1640 ft (500 m).

Analog inputs (AI)

Voltage signal ranges:

- 0.5 - 3.5 VDC, AL AU.
- 0-5 VDC, AU.
- 0-10 VDC, AU.

Voltage signal: $R_i > 100$ k Ω at 77 °F (+25 °C).

Leak currents may occur at high operating temperatures.

Keep the source impedance low.

Current signal ranges:

- 0-20 mADC, AU.
- 4-20 mADC, AL AU.

Current signal: $R_i = 292$ Ω .

Current overload protection: Yes. Change to voltage signal.

Measurement tolerance: - 0/+ 3 % of full scale (max.-point coverage).

Screened cable: 20-16 AWG (0.5 - 1.5 mm²).

Maximum cable length: 1640 ft (500 m) (excl. potentiometer).

Potentiometer connected to +5 V, GND, any AI:

Use maximum 10 k Ω .

Maximum cable length: 328 ft (100 m).

Analog output (AO)

Current sourcing capability only.

Voltage signal:

- Range: 0-10 VDC.
- Minimum load between AO and GND: 1 k Ω .
- Short-circuit protection: Yes.

Current signal:

- Ranges: 0-20 and 4-20 mA DC.
- Maximum load between AO and GND: 500 Ω .
- Open-circuit protection: Yes.

Tolerance: - 0/+ 4 % of full scale (max-point coverage).

Screened cable: 20-16 AWG (0.5 - 1.5 mm²).

Maximum cable length: 1640 ft (500 m)

Pt100/1000 inputs (PT)

Temperature range:

- Minimum -22 °F (-30 °C) (88 Ω /882 Ω).
- Maximum 356 °F (+180 °C) (168 Ω /1685 Ω).

Measurement tolerance: \pm 2.7 °F (1.5 °C).

Measurement resolution: < 0.54 °F (0.3 °C).

Automatic range detection (Pt100 or Pt1000): Yes.

Sensor fault alarm: Yes.

Screened cable: 20-16 AWG (0.5 - 1.5 mm²).

Use Pt100 for short wires.

Use Pt1000 for long wires.

LiqTec sensor inputs*

Use Grundfos LiqTec sensor only.

Screened cable: 20-16 AWG (0.5 - 1.5 mm²).

Power supplies (+5 V, +24 V)**+5 V:**

- Output voltage: 5 VDC - 5 %/+ 5 %.
- Maximum current: 50 mA DC (sourcing only).
- Overload protection: Yes.

+24 V:

- Output voltage: 24 VDC - 5 %/+ 5 %.
- Maximum current: 60 mA DC (sourcing only).
- Overload protection: Yes.

Digital outputs (relays)

Potential-free changeover contacts.

Minimum contact load when in use: 5 VDC, 10 mA.

Screened cable: 20-12 AWG (0.5 - 2.5 mm²).

Maximum cable length: 1640 ft (500 m).

Bus input

Grundfos GENIbus protocol, RS-485.

Screened 3-core cable: 20-16 AWG (0.5 - 1.5 mm²).

Maximum cable length: 1640 ft (500 m).

23. Other technical data**EMC (electromagnetic compatibility)**

EN 61800-3.

Residential areas, unlimited distribution, corresponding to CISPR 11, class B, group 1.

Industrial areas, unlimited distribution, corresponding to CISPR 11, class A, group 1.

Contact Grundfos for further information.

Enclosure class

Standard: IP55 (IEC 34-5).

Optional: IP66 (IEC 34-5).

Insulation class

F (IEC 85).

23.1 Torques

Terminal	Thread size	Max. torque [lbf-ft (Nm)]
L1, L2, L3, L, N	M4	1.3 (1.8)
NC, C1, C2, NO	M2.5	0.4 (0.5)
1 to 26 and A, Y, B	M2	0.4 (0.5)

23.2 Sound pressure level

Motor [hp (kW)]	Max. speed stated on nameplate [rpm]	Speed [rpm]	Sound pressure level ISO 3743 [dB(A)]	
			1-phase motors	3-phase motors
0.25 to 1.00 (0.12 to 0.75)	2000	1500	38	38
		2000	42	42
	4000	3000	53	53
		4000	58	58
1.50 (1.10)	2000	1500		38
		2000		42
	4000	3000	53	53
		4000	58	58
2.00 (1.50)	4000	3000	57	57
		4000	64	64
3.00 (2.20)	4000	3000		57
		4000		64

The grey fields indicate that the motor is not yet available in this MLE motor range, but is available in the previous MLE motor range.

24. Disposal

This product or parts of it must be disposed of in an environmentally sound way:

1. Use the public or private waste collection service.
2. If this is not possible, contact the nearest Grundfos company or service workshop.

The waste battery should be disposed of through the national collective schemes. If in doubt, contact your local Grundfos company.

Subject to alterations.

1. Installation in the USA and Canada

Note *In order to maintain the cURus approval, follow these additional installation instructions. The UL approval is according to UL 1004-1.*

1.1 Electrical codes

For USA

This product complies with the Canadian Electrical Code and the US National Electrical Code.
 This product has been tested according to the national standards for Electronically Protected Motors:
 CSA 22.2 100.04: 2009 (applies to Canada only).
 UL 1004-1: June 2011 (applies to USA only).

Pour le Canada

Codes de l'électricité

Ce produit est conforme au Code canadien de l'électricité et au Code national de l'électricité américain.
 Ce produit a été testé selon les normes nationales s'appliquant aux moteurs protégés électroniquement:
 CSA 22.2 100.04: 2009 (s'applique au Canada uniquement).
 UL 1004-1: Juin 2011 (s'applique aux États-Unis uniquement).

1.2 Radio communication

For USA

This device complies with part 15 of the FCC rules and RSS210 of IC rules.
 Operation is subject to the following two conditions:
 • This device may not cause interference.
 • This device must accept any interference, including interference that may cause undesired operation of the device.

Pour le Canada

Communication radio

Ce dispositif est conforme à la partie 15 des règles de la FCC et aux normes RSS210 de l'IC.
 Son fonctionnement est soumis aux deux conditions suivantes:
 • Ce dispositif ne doit pas provoquer de brouillage préjudiciable.
 • Il doit accepter tout brouillage reçu, y compris le brouillage pouvant entraîner un mauvais fonctionnement.

1.3 Identification numbers

For USA

Grundfos Holding A/S
 Contains FCC ID: OG3-RADIOM01-2G4.

For Canada

Grundfos Holding A/S
 Model: RADIOMODULE 2G4
 Contains IC: 10447A-RA2G4M01.

Pour le Canada

Numéros d'identification

Grundfos Holding A/S
 Modèle: RADIOMODULE 2G4
 Contient IC: 10447A-RA2G4M01.

Location of identification numbers

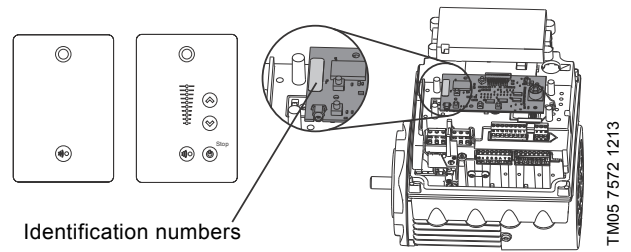

Fig. 1 Identification numbers

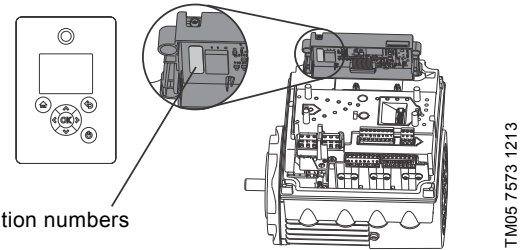

Fig. 2 Identification numbers

1.4 Electrical connection

1.4.1 Conductors

Use 140/167 °F (60/75 °C) copper conductors only.

1.4.2 Torques

Maximum tightening torques for the terminals can be found in section *Torques*, page 32.

1.4.3 Line reactors

Maximum line reactor size must not exceed 1.5 mH.

1.4.4 Fuse size/circuit breaker

If a short-circuit occurs, the pump can be used on a mains supply delivering not more than 5000 RMS symmetrical amperes, 600 V maximum.

Motor size [hp (kW)]	Fuse size	Circuit breaker type/model
0.50 to 3.00 (0.25 to 2.20 kW)	25 A	25 A / inverse time

Fuses

When the motor is protected by fuses, they must be rated for 480 V. Maximum sizes are stated in the table above.

Motors up to and including 3.00 hp [2.20 kW] require class K5 UR fuses.

Circuit breaker

When the pump is protected by a circuit breaker, this must be rated for a maximum voltage of 480 V. The circuit breaker must be of the "inverse time" type.

The interrupting rating (RMS symmetrical amperes) must not be less than the values stated in the table above.

1.4.5 Overload protection

Degree of overload protection provided internally by the drive, in percent of full-load current: 102 %.

Subject to alterations.

GRUNDFOS Kansas City

17100 West 118th Terrace
Olathe, Kansas 66061
Phone: (913) 227-3400
Fax: (913) 227-3500

www.grundfos.us

GRUNDFOS Canada

2941 Brighton Road
Oakville, Ontario L6H 6C9 Canada
Phone: +1-905 829 9533
Telefax: +1-905 829 9512

www.grundfos.ca

GRUNDFOS México

Boulevard TLC No. 15
Parque Industrial Stiva Aeropuerto
C.P. 66600 Apodaca, N.L. México
Phone: 011-52-81-8144 4000
Fax: 011-52-81-8144 4010

www.grundfos.mx

98649522 0514
ECM: 1135163

© Copyright Grundfos Holding A/S

The name Grundfos, the Grundfos logo, and be think innovate are registered trademarks owned by Grundfos Holding A/S or Grundfos A/S, Denmark. All rights reserved worldwide.