

# Hydro MPC



Service instructions





# Hydro MPC

---

## English (GB)

Service instructions .....	4
----------------------------	---

## Original service instructions

## Table of contents

<b>1. General information</b>	<b>4</b>
1.1 Hazard statements	4
1.2 Notes	4
<b>2. Identification</b>	<b>5</b>
2.1 Nameplate	5
2.2 Type key	6
2.3 Identification, IO 351	7
2.4 Identification, CU 352	7
2.5 Software label	7
<b>3. Technical data</b>	<b>8</b>
3.1 Pressure	8
3.2 Temperature	8
3.3 Relative humidity	8
3.4 Sound pressure level	8
3.5 Electrical data	8
<b>4. CU 352 and IO 351</b>	<b>9</b>
4.1 Functions of terminals, CU 352	9
4.2 Functions of terminals, IO 351A and IO 351B	9
4.2.1 IO 351A	9
4.2.2 IO 351B	9
4.2.3 Overview of inputs and outputs of modules	9
4.2.4 System type and IO module variants	10
4.2.5 Internal and external connections	11
4.2.6 CU 352 and IO 351 installation and operating instructions	27
<b>5. Fault correction tools</b>	<b>28</b>
5.1 MPC/CU 352 indicator lights and alarm relay	28
5.2 MPC display	28
5.2.1 Status (1)	28
5.2.2 Alarm log (3.2)	28
5.2.3 Passwords	29
5.2.4 Alarm list	29
5.3 Grundfos GO	32
5.4 PC Tool E-products	32
5.4.1 Network list	32
5.4.2 Monitor	32
5.4.3 Standard configuration	32
5.4.4 Custom configuration	32
5.4.5 Data logging	32
5.4.6 Updating configuration files	32
<b>6. Configuration of Hydro MPC</b>	<b>32</b>
6.1 Necessary equipment	32
6.2 Factory configuration of Hydro MPC	32
6.2.1 Setting the GENIbus number in IO 351 modules, if any	32
6.2.2 Configuration of CU 352	33
6.2.3 Configuration of external frequency converters, if any	35
6.2.4 Step-by-step configuration of E-pumps, if any	38
<b>7. Danfoss frequency converters</b>	<b>39</b>
<b>8. CUE</b>	<b>39</b>
<b>9. MGE</b>	<b>39</b>
<b>10. Disposal</b>	<b>40</b>
10.1 Precautions for disposal	40
10.2 Disposing of the system	40

## 1. General information



Read this document before you start service work on the system. Service work must comply with local regulations and accepted codes of good practice. Observe the safety instructions in the installation and operating instructions for the system.

## 1.1 Hazard statements

The symbols and hazard statements below may appear in Grundfos installation and operating instructions, safety instructions and service instructions.

**DANGER**

Indicates a hazardous situation which, if not avoided, will result in death or serious personal injury.

**WARNING**

Indicates a hazardous situation which, if not avoided, could result in death or serious personal injury.

**CAUTION**

Indicates a hazardous situation which, if not avoided, could result in minor or moderate personal injury.

The hazard statements are structured in the following way:

**SIGNAL WORD****Description of the hazard**

Consequence of ignoring the warning

- Action to avoid the hazard.

## 1.2 Notes

The symbols and notes below may appear in Grundfos installation and operating instructions, safety instructions and service instructions.



Observe these instructions for explosion-proof products.



A blue or grey circle with a white graphical symbol indicates that an action must be taken.



A red or grey circle with a diagonal bar, possibly with a black graphical symbol, indicates that an action must not be taken or must be stopped.



If these instructions are not observed, it may result in malfunction or damage to the equipment.



Tips and advice that make the work easier.

## 2. Identification

This section shows the nameplate, the type key and the codes that can appear in the variant code.



As codes can be combined, a code position may contain more than one code (letter).

### 2.1 Nameplate

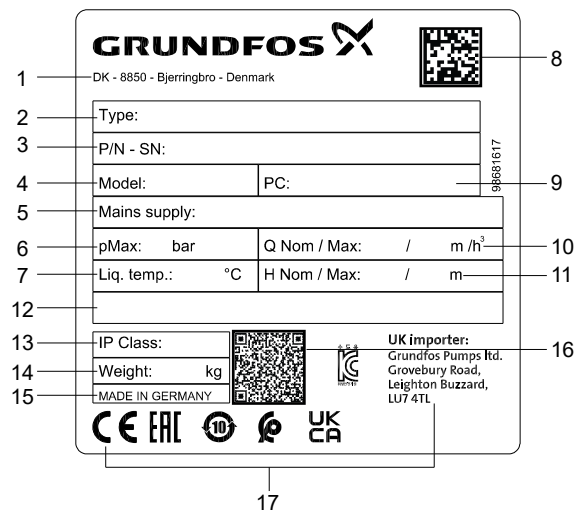

TM083039

*Nameplate example*

Pos.	Description
1	Company address
2	Product type
3	Product number and Serial number
4	Model number
5	Mains supply
6	Max. operating pressure
7	Liquid temperature
8	Barcode
9	Production code
10	Nominal flow rate and maximum flow rate
11	Normal head and maximum head
12	Technical documents
13	IP class
14	Weight
15	Country of origin
16	QR code
17	Marks of approval

## 2.2 Type key

## Example: Hydro MPC-E 6 CRNE155-1-1 U1 A-A-A-ABCD

Code	Explanation	Designation
Hydro MPC		System name
E	E: All pumps E Motor or CUE F: Fixed speed pumps, 1 CUE	S: Fixed speed pumps X: Customised system type System type
6		Number of main pumps
CRNE155-1-1		Pump type
U1	U1: 3 x 380-415 V, N, PE, 50/60 Hz U2: 3 x 380-415 V, PE, 50/60 Hz U3: 3 x 380-415 V, N, PE, 50 Hz U4: 3 x 380-415 V, PE, 50 Hz U5: 3 x 380-415V, N, PE, 60 Hz U6: 3 x 380-415 V, PE, 60 Hz U7: 1 x 200-240 V, PE, 50/60 Hz U8: 1 x 200-240 V, N, PE, 50/60 Hz U9: 3 x 220-240 V, PE, 60 Hz	UA: 3 x 440-480 V, PE, 60 Hz UB: 1 x 220-240 V, N, PE, 50/60 Hz UC: 1 x 220-240 V, N, PE, 50 Hz UD: 3 x 440-480 V, N, PE, 60 Hz UJ: 1 x 208-230 V, PE, 60 Hz UK: 3 x 208-230 V, PE, 60 Hz UL: 3 x 460-480 V, PE, 60 Hz UX: CSU variant (special voltage rating) Voltage code
A	A: Systems with the control cabinet mounted on the same base frame as the pumps. B: Systems with the control cabinet centred on the base frame. C: Systems with the control cabinet mounted on its own base for floor mounting. The control cabinet can be placed up to 2 metres from the pumps. C: Systems with the control cabinet mounted on its own base for floor mounting. The control cabinet can be placed up to 50 ft from the pumps. D: Systems with the control cabinet mounted on its own base frame. The control cabinet can be placed up to 2 metres from the pumps. D: Systems with the control cabinet mounted on its own base frame. The control cabinet can be placed up to 50 ft from the pumps. E: APAC design. Systems with the control cabinet mounted on the same base frame as the pumps. F: APAC design. Systems with the control cabinet centred on the base frame. G: APAC design. Systems with the control cabinet mounted on its own base for floor mounting. The control cabinet can be placed up to 2 metres from the pumps. H: APAC design. Systems with the control cabinet mounted on its own base frame. The control cabinet can be placed up to 2 metres from the pumps. I: APAC design. Systems with the control cabinet prepared for wall mounting. The control cabinet can be placed up to 2 metres from the pumps. W: Systems with the control cabinet prepared for wall mounting. The control cabinet can be placed up to 2 metres from the pumps.	Design
A	A: E B: DOL C: SD	Starting method
A	A: Stainless steel manifold and base frame, and standard valves B: Stainless steel manifold, base frame and valves C: Galvanised steel manifold and base frame, and standard valves D: Stainless steel manifold, galvanised steel base frame, and standard valves H: Galvanised steel manifold and base frame painted black, and standard valves I: Stainless steel manifold and base frame painted black, and standard valves X: Customised material combination	Material combination
ABCD	A: Standard hydraulic, PN 16 B: Pilot pump C: Bypass D: NRV on inlet E: Elbow manifold F: No inlet manifold G: Diaphragm tank H: Dry-running protection I: Repair switch J: Redundant sensor or switch K: 1 free pump position L: 2 free pump position M: 3 free pump position	N: PN 10 pressure rating O: PN 25 pressure rating P: Low prepressure Q: PN 40 pressure rating R: RPM = 50 Hz S: Customised variant T: Certificate U: Undersized motor V: Standard controls with options W: Customised controls 3W: Hydro DDD panel X: More than 4 options Y: Control cabinet with double door Option

## 2.3 Identification, IO 351

### Nameplate

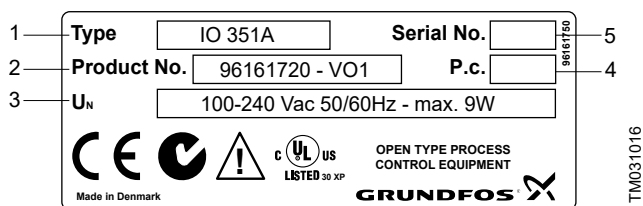

Nameplate, IO 351A

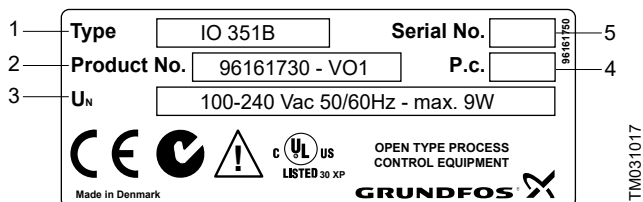

Nameplate, IO 351B

Pos.	Description
1	Type designation
2	Product and version numbers
3	Permissible supply voltage, frequency and maximum power consumption
4	Production code (year and week)
5	Serial number

### Type key

Example: IO 35 1 B

Code	Explanation
IO	Input-output module
35	Controller series
1	Model number
B	A: For pumps with fixed speed B: For pumps with fixed speed and pumps in F-systems controlled by external frequency converters or the CUE, or as input-output module

## 2.4 Identification, CU 352

### Nameplate

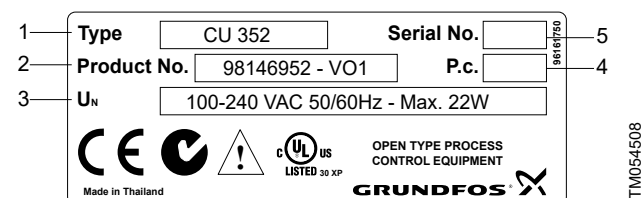

Nameplate, CU 352

Pos.	Description
1	Type designation
2	Product and version numbers
3	Permissible supply voltage, frequency and maximum power consumption
4	Production code (year and week)
5	Serial number

### Type key

Example: CU 35 2 O

Code	Explanation
CU	Control unit
35	Controller series
2	Model number
O	For panel mounting

## 2.5 Software label

The software label is placed on the back of the CU 352.

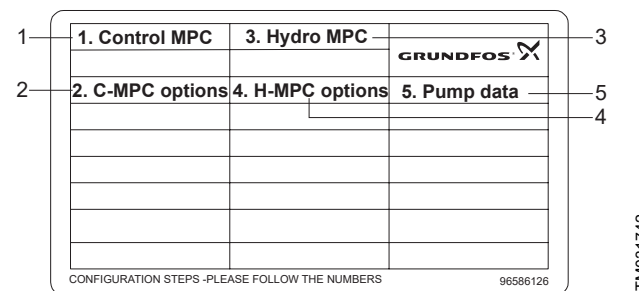

### Software label

Pos.	Description
1	Control MPC - GSC file number
2	Control MPC options - GSC file numbers
3	Hydro MPC - GSC file number <sup>1)</sup>
4	Hydro MPC options - GSC file numbers <sup>1)</sup>
5	Pump data - GSC file number <sup>2)</sup>

1) Applies only to systems.

2) Applies only to CR, CRI, CRN, CRE and CRIE pumps.



A GSC (Grundfos Standard Configuration) file is a configuration data file.

### 3. Technical data

#### 3.1 Pressure

##### Inlet pressure

The Hydro MPC systems can operate with a positive inlet pressure (precharged pressure system) or with a negative inlet pressure (vacuum at the inlet manifold).

We recommend that you calculate the inlet pressure in these cases:

- Water is drawn through long pipes.
- Water is drawn from depths.
- Inlet conditions are poor.



In this document, the term "inlet pressure" is defined as the pressure or vacuum which can be measured immediately before the system.

To avoid cavitation, make sure that there is a minimum inlet pressure on the inlet side of the system. The minimum inlet pressure  $H$  in metres of head can be calculated as follows:

$$H = p_b \times 10.2 - NPSH - H_f - H_v - H_s$$

$p_b$	Barometric pressure in bar. Barometric pressure can be set to 1 bar. In closed systems, $p_b$ indicates the system pressure in bar.
NPSH	Net Positive Suction Head in metres of head. NPSH can be read from the NPSH curve at the highest flow which the individual pump will be delivering.
$H_f$	Friction loss in inlet manifold in metres of head at the highest flow the individual pump will be delivering. Note: If a non-return valve is installed on the inlet side of the pump, the friction loss in the valve must be added. See the manufacturer's data.
$H_v$	Vapour pressure in metres of head.
$H_s$	Safety margin of min. 0.5 metres of head.



You need to convert the head in metres to feet.

##### Maximum inlet pressure

See the CR, CRI, CRN installation and operating instructions supplied with this system.

##### Operating pressure

As standard, the maximum operating pressure is 16 bar.

On request, Grundfos offers Hydro MPC systems with a maximum operating pressure higher than 16 bar.

##### Operating pressure

As standard, the maximum operating pressure is 232 psi (16 bar) for Hydro MPC CR, CRE and 145 psi (10 bar) for Hydro MPC CME.

On request, Grundfos offers Hydro MPC systems with a maximum operating pressure higher than 232 psi (16 bar).

#### 3.2 Temperature

Liquid temperature	5-60 °C
Ambient temperature	0-40 °C

Higher liquid temperature capability is available on request.

#### 3.3 Relative humidity

Maximum 95 %.

#### 3.4 Sound pressure level

See the installation and operating instructions for the CR pumps.

The sound pressure level for a number of pumps can be calculated as follows:

$$L_{max} = L_{pump} + (n - 1) \times 3$$

$L_{max}$	Maximum sound pressure level
$L_{pump}$	Sound pressure level for one pump
$n$	Number of pumps

#### 3.5 Electrical data

##### Supply voltage

See the nameplate.

##### Backup fuse

See the wiring diagram supplied with the system.

##### Digital inputs

Open-circuit voltage	24 VDC
Closed-circuit current	5 mA, DC
Frequency range	0-4 Hz



All digital inputs are supplied with PELV voltage (Protective Extra-Low Voltage).

##### Analog inputs

Input current and voltage	0-20 mA 4-20 mA 0-10 V
Tolerance	± 3.3 % of full scale
Repetitive accuracy	± 1 % of full scale
Input resistance, current	< 250 Ω
Input resistance, voltage, CU 352	50 kΩ ± 10 %
Input resistance, voltage, IO 351	> 50 kΩ ± 10 %
Supply to sensor	24 V, maximum 50 mA, short-circuit protected



All analog inputs are supplied with PELV voltage (Protective Extra-Low Voltage).

##### Digital outputs (relay outputs)

Maximum contact load	240 VAC, 2 A
Minimum contact load	5 VDC, 10 mA

All digital outputs are potential-free relay contacts.



Some outputs have a common C terminal.  
For further information, see the wiring diagram supplied with the system.

##### Inputs for PTC sensor or thermal switch

For PTC sensors to DIN 44082. Thermal switches can also be connected.

Open-circuit voltage	12 VDC ± 15 %
Closed-circuit current	2.6 mA, DC



Inputs for PTC sensors are electrically separated from the other inputs and outputs of the system.



## 4. CU 352 and IO 351

### 4.1 Functions of terminals, CU 352

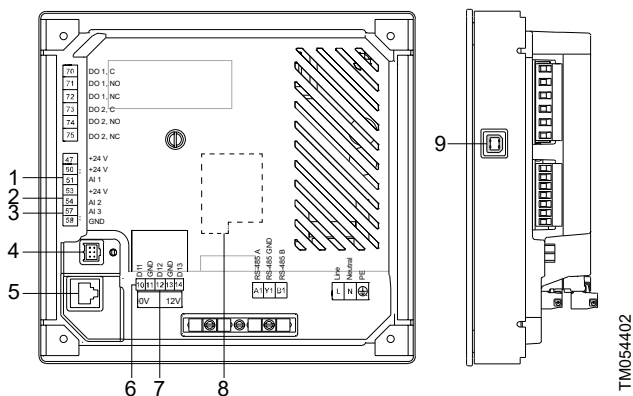

Functions of terminals, CU 352

Pos.	Default settings
1	Outlet pressure
2	Inlet pressure (disabled if no sensor is connected)
3	Configurable analog input (disabled if no sensor is connected)
4	PC Tool connection, TTL
5	Ethernet connection
6	External start/stop
7	Water shortage, pressure/level switch
8	Optional CIM card
9	PC Tool connection, USB

### 4.2 Functions of terminals, IO 351A and IO 351B

#### 4.2.1 IO 351A

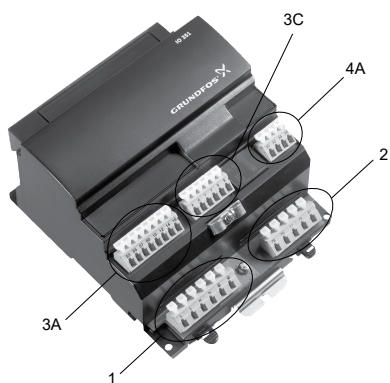

Terminal groups

The module can be divided into these groups:

Group 1	Connection of power supply
Group 2	Digital outputs 1-3
Groups 3A, 3C	Digital inputs GENiBus
Group 4A	Inputs for PTC sensor or thermal switch

#### 4.2.2 IO 351B

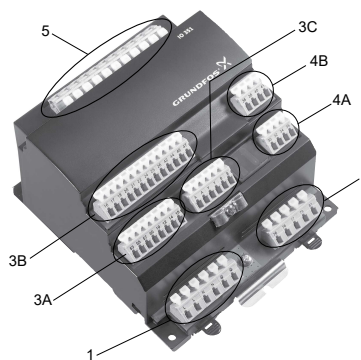

Terminal groups

The module can be divided into these groups:

Group 1	Connection of power supply
Group 2	Digital outputs 1-3
Groups 3A, 3B, 3C	Digital inputs Analog inputs and outputs GENiBus
Groups 4A, 4B	Inputs for PTC sensor or thermal switch
Group 5	Digital outputs 4-7

#### 4.2.3 Overview of inputs and outputs of modules

Type	Pump module A	Pump module B	IO module B
Analog input	Not used	Not used	2
Analog output	-	3	Not used
Digital input	3	9	9
PTC input	3	6	Not used
Digital output	3	7	7

The table below shows the modules and the GENiBus number of the individual system types.

System type and number of pumps	Module required in addition to the CU 352	GENiBus number
E	-	-
ES up to four pumps	A	31
ES five or six pumps	B	31
ED up to five pumps	A	31
ED six pumps	B	31
EDF up to six pumps	B	31
EF up to three pumps	B	31
EF four to six pumps	B + B	31 + 32
F up to three pumps	B	31
F four to six pumps	B + B	31 + 32
S up to three pumps	A	31
S four to six pumps	B	31
	General module	41
	Operating light module	41
	General module + operating light module	41 + 42

TM032110

TM054402

TM081694

## 4.2.4 System type and IO module variants

System type	Maximum number of pumps	Controller/module	GENibus address		Pump number					
			Module	E-pump	1	2	3	4	5	6
E	6	CU 352		1-6	E	E	E	E	E	E
ES	4	CU 352	-	1	E	-	-	-	-	-
		IO 351A	31	-	-	S	S	S	-	-
	6	CU 352	-	1	E	-	-	-	-	-
		IO 351B	31	-	-	S	S	S	S	S
ED	5	CU 352	-	1-2	E	E	-	-	-	-
		IO 351A	31	-	-	-	S	S	S	-
	6	CU 352	-	1-2	E	E	-	-	-	-
		IO 351B	31	-	-	-	S	S	S	S
EDF	6	CU 352	-	-	-	-	-	-	-	-
		IO 351B	31	-	EF	EF	S	S	S	S
EF	6	CU 352	-	-	-	-	-	-	-	-
		IO 351B	31	-	EF	EF	EF	-	-	-
F	6	IO 351B	32	-	-	-	-	EF	EF	EF
		CU 352	-	-	-	-	-	-	-	-
S	3	IO 351B	31	-	F/S	F/S	F/S	-	-	-
		IO 351B	32	-	-	-	-	F/S	F/S	F/S
	6	CU 352	-	-	-	-	-	-	-	-
		IO 351A	31	-	S	S	S	-	-	-
	6	CU 352	-	-	-	-	-	-	-	-
		IO 351B	31	-	S	S	S	S	S	S
<b>Accessory</b>										
All		IO 351B	41 <sup>3)</sup>	-	Data exchange, for instance to a PLC					
		2 x IO 351B	41, 42 <sup>4)</sup>							

3) Interface module or operating module.

4) Interface module and operating module.

## Legend

Pump number	Description
E	0.37 to 22 kW are E-pumps with integrated frequency converter. 30 to 55 kW are variable-speed pumps controlled by Grundfos CUE frequency converters.
S	Mains-operated pump.
EF	Variable-speed pump controlled by an external frequency converter (not CUE).
F/S	Mains-operated pump or variable-speed pump controlled via a common frequency converter.

### 4.2.5 Internal and external connections

This section shows the internal and external connections. The section is split up according to the various system types.

Abbreviations used:

- DI: Digital input
- DO: Digital output
- AO: Analog output
- AI: Analog input
- C: Common.

#### E systems, CU 352

Group	Terminal	Designation	Data	Diagram	
1	L	Connection to phase conductor	1 × 100-240 VAC ± 10 %, 50/60 Hz		TM086695
	N	Connection to neutral conductor			
	PE	Connection to protective earth			
2	A1	RS-485 A	GENIbus (Fix the screen with a cable clamp.)		TM086696
	Y1	RS-485 GND			
	B1	RS-485 B			
		Functional earth			
3	Connection to external fieldbus. See installation and operating instructions for the CIM module.				
4	0 V +12 VDC	Connection to battery	Backup battery		
5	10	DI1	Digital input		TM086697
	11	GND			
	12	DI2			
	13	GND			
	14	DI3			
All terminals (except mains terminals) must only be connected to voltages not exceeding 16 V <sub>rms</sub> and 22.6 V <sub>peak</sub> or 35 VDC.					
6	Ethernet RJ45				
External computing devices connected to the Ethernet connection must comply with the standards IEC 60950 and UL 60950.					
7	GENIbus		Service connection		
8	47	+24 V	Supply to sensor. Short-circuit-protected 30 mA		TM086698
	50	+24 V	Supply to sensor. Short-circuit-protected 30 mA		
	51	AI1	Input for analog signal, 0/4-20 mA or 0-10 V		
	53	+24 V	Supply to sensor. Short-circuit-protected 30 mA		
	54	AI2	Input for analog signal, 0/4-20 mA or 0-10 V		
	57	AI3	Input for analog signal, 0/4-20 mA or 0-10 V		
	58	GND <sup>5)</sup>			
All terminals (except mains terminals) must only be connected to voltages not exceeding 16 V <sub>rms</sub> and 22.6 V <sub>peak</sub> or 35 VDC.					
9	USB port		USB 2.0, type B		
10	70		C		TM086699
	71	Relay 1	NO		
	72		NC		
	73		C		
	74	Relay 2	NO		
	75		NC		

5) GND is separated from other earth connections.

ES systems, IO 351, GENibus number 31

Group	Terminal	Designation	Data	Diagram for standard configuration	
1	L	Phase conductor	1 × 100-240 VAC ± 10 %, 50/60 Hz		TM086700
	L				
	N	Neutral conductor			
	N				
		PE			
2	76	DO1, 2, 3 C	Relay contact, NO Maximum load: 240 VAC, 2 A Minimum load: 5 VDC, 10 mA		TM086701
	76	DO1, 2, 3 C			
	77	DO1 NO			
	79	DO2 NO			
	81	DO3 NO			
3A	10	DI1	Digital input		TM086702
	12	DI2			
	14	DI3			
	15	GND			
The terminals must only be connected to voltages of maximum 16 V <sub>rms</sub> and 22.6 V <sub>peak</sub> or 35 VDC. Fit jumpers instead of the external stops for which the controller is designed.					
3A	53	+24 V	Supply to sensor. Max. 50 mA		TM086703
	55	GND			
	57	AI1	Input for analog signal, 0/4-20 mA or 0-10 V		
	60	AI2			
The terminals must only be connected to voltages of maximum 16 V <sub>rms</sub> and 22.6 V <sub>peak</sub> or 35 VDC.					
3C	A	RS-485 A	GENibus (internal) (Fix the screen with a cable clamp.)		TM086704
	A	RS-485 A			
	Y	RS-485 GND <sup>6)</sup>			
	Y	RS-485 GND <sup>6)</sup>			
	B	RS-485 B			
		B	RS-485 B		
			Functional earth		
4A	30	PTC1	Input for PTC sensor or thermal switch  Fit jumpers if no PTC sensor or thermal switch is connected.  The terminals must only be connected to voltages of maximum 16 V <sub>rms</sub> and 22.6 V <sub>peak</sub> or 35 VDC.		TM086705
	32	PTC2			
	34	PTC3			
	35	GND, PTC			

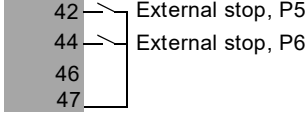
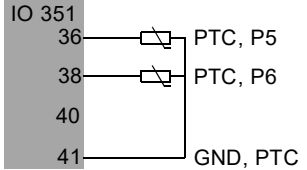
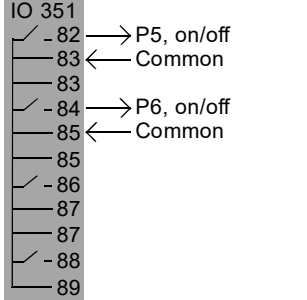
Group	Terminal	Designation	Data	Diagram for standard configuration
3B	16	DI4	Digital input	<p>Cannot be used.</p> 
	17	GND		
	18	AO4	Analog output, 0-10 V	
	20	DI5	Digital input	
	21	GND		
	22	AO5	Analog output, 0-10 V	
	24	DI6	Digital input	
	25	GND		
	26	AO6	Analog output	
	42	DI7		
	44	DI8	Digital input	
	46	DI9		
47	GND			
Fit jumpers instead of the external stops for which the controller is designed.				
4B	36	PTC4		
	38	PTC5	Input for PTC sensor or thermal switch	
	40	PTC6		
	41	GND, PTC		
Fit jumpers if no PTC sensor or thermal switch is connected.				
The terminals must only be connected to voltages of maximum 16 V <sub>rms</sub> and 22.6 V <sub>peak</sub> or 35 VDC.				
5	82	DO4 NO		
	83	DO4 C		
	83	DO4 C		
	84	DO5 NO		
	85	DO5 C	Relay contact, NO	
	85	DO5 C	Maximum load: 240 VAC, 2 A	
	86	DO6 NO	Minimum load: 5 VDC, 10 mA	
	87	DO6 C		
	87	DO6 C		
	88	DO7 NO		
89	DO7 C			

TM086706

TM086707

TM086708

6) GND is separated from other earth connections.

ED systems, IO 351, GENibus number 31

Group	Terminal	Designation	Data	Diagram for standard configuration	
1	L	Phase conductor	$1 \times 100-240 \text{ VAC} \pm 10 \%, 50/60 \text{ Hz}$		TM086700
	L				
	N	Neutral conductor			
	N				
		PE			
2	76	DO1, 2, 3 C	Relay contact, NO Maximum load: 240 VAC, 2 A Minimum load: 5 VDC, 10 mA		TM086714
	76	DO1, 2, 3 C			
	77	DO1 NO			
	79	DO2 NO			
	81	DO3 NO			
3A	10	DI1	Digital input		TM086715
	12	DI2			
	14	DI3			
	15	GND			
The terminals must only be connected to voltages of maximum $16 V_{\text{rms}}$ and $22.6 V_{\text{peak}}$ or 35 VDC. Fit jumpers instead of the external stops for which the controller is designed.					
3A	53	+24 V	Supply to sensor. Max. 50 mA		TM086703
	55	GND			
	57	AI1	Input for analog signal, 0/4-20 mA or 0-10 V		
	60	AI2			
The terminals must only be connected to voltages of maximum $16 V_{\text{rms}}$ and $22.6 V_{\text{peak}}$ or 35 VDC.					
3C	A	RS-485 A	GENibus (internal) (Fix the screen with a cable clamp.)		TM086704
	A	RS-485 A			
	Y	RS-485 GND <sup>7)</sup>			
	Y	RS-485 GND <sup>7)</sup>			
	B	RS-485 B			
	B	RS-485 B			
		Functional earth			
4A	30	PTC1	Input for PTC sensor or thermal switch  Fit jumpers if no PTC sensor or thermal switch is connected. The terminals must only be connected to voltages of maximum $16 V_{\text{rms}}$ and $22.6 V_{\text{peak}}$ or 35 VDC.		TM086716
	32	PTC2			
	34	PTC3			
	35	GND, PTC			

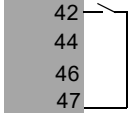
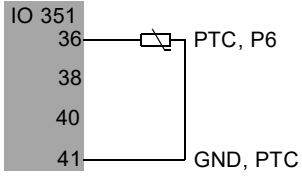
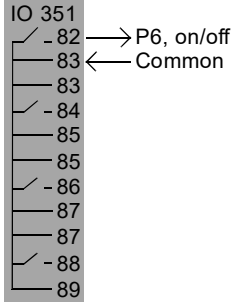
Group	Terminal	Designation	Data	Diagram for standard configuration	
3B	16	DI4	Digital input	<p>Cannot be used.</p> 	
	17	GND			
	18	AO4	Analog output, 0-10 V		
	20	DI5	Digital input		
	21	GND			
	22	AO5	Analog output, 0-10 V		
	24	DI6	Digital input		
	25	GND			
	26	AO6	Analog output		
	42	DI7			
4B	36	PTC4	Input for PTC sensor or thermal switch		
	38	PTC5			
	40	PTC6			
	41	GND, PTC			
Fit jumpers instead of the external stops for which the controller is designed.				<p>TM086717</p>	
Fit jumpers if no PTC sensor or thermal switch is connected.					
The terminals must only be connected to voltages of maximum 16 V <sub>rms</sub> and 22.6 V <sub>peak</sub> or 35 VDC.					
5	82	DO4 NO	Relay contact, NO Maximum load: 240 VAC, 2 A Minimum load: 5 VDC, 10 mA		
	83	DO4 C			
	83	DO4 C			
	84	DO5 NO			
	85	DO5 C			
	85	DO5 C			
	86	DO6 NO			
	87	DO6 C			
	87	DO6 C			
	88	DO7 NO			
	89	DO7 C			
				<p>TM086718</p> <p>TM086719</p>	

7) GND is separated from other earth connections.

EDF systems, IO 351, GENibus number 31

Group	Terminal	Designation	Data	Diagram for standard configuration	
1	L	Phase conductor	1 × 100-240 VAC ± 10 %, 50/60 Hz		TM086700
	L				
	N	Neutral conductor			
	N				
		PE			
2	76	DO1, 2, 3 C	Relay contact, NO Maximum load: 240 VAC, 2 A Minimum load: 5 VDC, 10 mA		TM086720
	76	DO1, 2, 3 C			
	77	DO1 NO			
	79	DO2 NO			
	81	DO3 NO			
3A	10	DI1	Digital input		TM086721
	12	DI2			
	14	DI3			
	15	GND			
The terminals must only be connected to voltages of maximum 16 V <sub>rms</sub> and 22.6 V <sub>peak</sub> or 35 VDC. Fit jumpers instead of the external stops for which the controller is designed.					
3A	53	+24 V	Supply to sensor. Max. 50 mA		TM086703
	55	GND			
	57	AI1	Input for analog signal, 0/4-20 mA or 0-10 V		
	60	AI2			
The terminals must only be connected to voltages of maximum 16 V <sub>rms</sub> and 22.6 V <sub>peak</sub> or 35 VDC.					
3C	A	RS-485 A	GENibus (internal) (Fix the screen with a cable clamp.)		TM086704
	A	RS-485 A			
	Y	RS-485 GND <sup>8)</sup>			
	Y	RS-485 GND <sup>8)</sup>			
	B	RS-485 B			
	B	RS-485 B			
		Functional earth			
4A	30	PTC1	Input for PTC sensor or thermal switch  Fit jumpers if no PTC sensor or thermal switch is connected.  The terminals must only be connected to voltages of maximum 16 V <sub>rms</sub> and 22.6 V <sub>peak</sub> or 35 VDC.		TM086722
	32	PTC2			
	34	PTC3			
	35	GND, PTC			



Group	Terminal	Designation	Data	Diagram for standard configuration
3B	16	DI4	Digital input	
	17	GND		
	18	AO4	Analog output, 0-10 V	
	20	DI5	Digital input	
	21	GND		
	22	AO5	Analog output, 0-10 V	
	24	DI6	Digital input	
	25	GND		
	26	AO6	Analog output	
	42	DI7		
44	DI8	Digital input		
46	DI9			
47	GND			
Fit jumpers instead of the external stops for which the controller is designed.				
4B	36	PTC4		
	38	PTC5	Input for PTC sensor or thermal switch	
	40	PTC6		
	41	GND, PTC		
Fit jumpers if no PTC sensor or thermal switch is connected.				
The terminals must only be connected to voltages of maximum 16 V <sub>rms</sub> and 22.6 V <sub>peak</sub> or 35 VDC.				
5	82	DO4 NO		
	83	DO4 C		
	83	DO4 C		
	84	DO5 NO		
	85	DO5 C	Relay contact, NO	
	85	DO5 C	Maximum load: 240 VAC, 2 A	
	86	DO6 NO	Minimum load: 5 VDC, 10 mA	
	87	DO6 C		
	87	DO6 C		
	88	DO7 NO		
89	DO7 C			

8) GND is separated from other earth connections.

EF systems, module B1, IO 351, GENIbus number 31

Group	Terminal	Designation	Data	Diagram for standard configuration	
1	L	Phase conductor	1 × 100-240 VAC ± 10 %, 50/60 Hz		TM086700
	L				
	N	Neutral conductor			
	N				
		PE			
2	76	DO1, 2, 3 C	Relay contact, NO Maximum load: 240 VAC, 2 A Minimum load: 5 VDC, 10 mA		TM086727
	76	DO1, 2, 3 C			
	77	DO1 NO			
	79	DO2 NO			
	81	DO3 NO			
3A	10	DI1	Digital input		TM086721
	12	DI2			
	14	DI3			
	15	GND			
The terminals must only be connected to voltages of maximum 16 V <sub>rms</sub> and 22.6 V <sub>peak</sub> or 35 VDC.					
Fit jumpers instead of the external stops for which the controller is designed.					
3A	53	+24 V	Supply to sensor. Max. 50 mA		TM086703
	55	GND			
	57	AI1			
	60	AI2			
The terminals must only be connected to voltages of maximum 16 V <sub>rms</sub> and 22.6 V <sub>peak</sub> or 35 VDC.					
3C	A	RS-485 A	GENIbus (internal) (Fix the screen with a cable clamp.)		TM086704
	A	RS-485 A			
	Y	RS-485 GND <sup>9)</sup>			
	Y	RS-485 GND <sup>9)</sup>			
	B	RS-485 B			
	B	RS-485 B			
		Functional earth			
4A	30	PTC1	Input for PTC sensor or thermal switch		TM086722
	32	PTC2			
	34	PTC3			
	35	GND, PTC			
Fit jumpers if no PTC sensor or thermal switch is connected.					
The terminals must only be connected to voltages of maximum 16 V <sub>rms</sub> and 22.6 V <sub>peak</sub> or 35 VDC.					

Group	Terminal	Designation	Data	Diagram for standard configuration	
3B	16	DI4	Digital input		TM086728
	17	GND			
	18	AO4	Analog output, 0-10 V		
	20	DI5	Digital input		
	21	GND			
	22	AO5	Analog output, 0-10 V		
	24	DI6	Digital input		
	25	GND			
	26	AO6	Analog output		
	3B	42	DI7		
44		DI8	Digital input		
46		DI9			
47		GND			
Fit jumpers instead of the external stops for which the controller is designed.					
4B	36	PTC4			TM086730
	38	PTC5	Input for PTC sensor or thermal switch		
	40	PTC6			
	41	GND, PTC			
Fit jumpers if no PTC sensor or thermal switch is connected.					
The terminals must only be connected to voltages of maximum 16 V <sub>rms</sub> and 22.6 V <sub>peak</sub> or 35 VDC.					
5	82	DO4 NO			TM086731
	83	DO4 C			
	83	DO4 C			
	84	DO5 NO			
	85	DO5 C	Relay contact, NO		
	85	DO5 C	Maximum load: 240 VAC, 2 A		
	86	DO6 NO	Minimum load: 5 VDC, 10 mA		
	87	DO6 C			
	87	DO6 C			
	88	DO7 NO			
89	DO7 C				

9) GND is separated from other earth connections.

EF systems, module B2, IO 351, GENIbus number 32

Group	Terminal	Designation	Data	Diagram for standard configuration	
1	L	Phase conductor	1 × 100-240 VAC ± 10 %, 50/60 Hz		TM086700
	L				
	N	Neutral conductor			
	N				
		PE			
2	76	DO1, 2, 3 C	Relay contact, NO Maximum load: 240 VAC, 2 A Minimum load: 5 VDC, 10 mA		TM086727
	76	DO1, 2, 3 C			
	77	DO1 NO			
	79	DO2 NO			
	81	DO3 NO			
3A	10	DI1	Digital input		TM086732
	12	DI2			
	14	DI3			
	15	GND			
The terminals must only be connected to voltages of maximum 16 V <sub>rms</sub> and 22.6 V <sub>peak</sub> or 35 VDC. Fit jumpers instead of the external stops for which the controller is designed.					
3A	53	+24 V	Supply to sensor. Max. 50 mA		TM086703
	55	GND			
	57	AI1	Input for analog signal, 0/4-20 mA or 0-10 V		
	60	AI2			
The terminals must only be connected to voltages of maximum 16 V <sub>rms</sub> and 22.6 V <sub>peak</sub> or 35 VDC.					
3C	A	RS-485 A	GENIbus (internal) (Fix the screen with a cable clamp.)		TM086704
	A	RS-485 A			
	Y	RS-485 GND <sup>10)</sup>			
	Y	RS-485 GND <sup>10)</sup>			
	B	RS-485 B			
	B	RS-485 B			
		Functional earth			
4A	30	PTC1	Input for PTC sensor or thermal switch		TM086733
	32	PTC2			
	34	PTC3			
	35	GND, PTC			
Fit jumpers if no PTC sensor or thermal switch is connected. The terminals must only be connected to voltages of maximum 16 V <sub>rms</sub> and 22.6 V <sub>peak</sub> or 35 VDC.					

Group	Terminal	Designation	Data	Diagram for standard configuration			
3B	16	DI4	Digital input		TM086734		
	17	GND					
	18	AO4	Analog output, 0-10 V				
	20	DI5	Digital input				
	21	GND					
	22	AO5	Analog output, 0-10 V				
	24	DI6	Digital input				
	25	GND					
	26	AO6	Analog output				
	42	DI7					
	44	DI8	Digital input				TM086729
	46	DI9					
47	GND						
Fit jumpers instead of the external stops for which the controller is designed.							
4B	36	PTC4			TM086730		
	38	PTC5	Input for PTC sensor or thermal switch				
	40	PTC6					
	41	GND, PTC					
Fit jumpers if no PTC sensor or thermal switch is connected.							
The terminals must only be connected to voltages of maximum 16 V <sub>rms</sub> and 22.6 V <sub>peak</sub> or 35 VDC.							
5	82	DO4 NO			TM086735		
	83	DO4 C					
	83	DO4 C					
	84	DO5 NO					
	85	DO5 C	Relay contact, NO				
	85	DO5 C	Maximum load: 240 VAC, 2 A				
	86	DO6 NO	Minimum load: 5 VDC, 10 mA				
	87	DO6 C					
	87	DO6 C					
	88	DO7 NO					
89	DO7 C						

<sup>10)</sup> GND is separated from other earth connections.

F systems, module B1, IO 351, GENIbus number 31

Group	Terminal	Designation	Data	Diagram for standard configuration	
1	L	Phase conductor	1 × 100-240 VAC ± 10 %, 50/60 Hz		TM086700
	L				
	N	Neutral conductor			
	N				
	PE				
2	76	DO1, 2, 3 C	Relay contact, NO Maximum load: 240 VAC, 2 A Minimum load: 5 VDC, 10 mA		TM086736
	76	DO1, 2, 3 C			
	77	DO1 NO			
	79	DO2 NO			
	81	DO3 NO			
3A	10	DI1	Digital input		TM086721
	12	DI2			
	14	DI3			
	15	GND			
The terminals must only be connected to voltages of maximum 16 V <sub>rms</sub> and 22.6 V <sub>peak</sub> or 35 VDC. Fit jumpers instead of the external stops for which the controller is designed.					
3A	53	+24 V	Supply to sensor. Max. 50 mA		TM086703
	55	GND			
	57	AI1	Input for analog signal, 0/4-20 mA or 0-10 V		
	60	AI2			
The terminals must only be connected to voltages of maximum 16 V <sub>rms</sub> and 22.6 V <sub>peak</sub> or 35 VDC.					
3C	A	RS-485 A	GENIbus (internal) (Fix the screen with a cable clamp.)		TM086704
	A	RS-485 A			
	Y	RS-485 GND <sup>11)</sup>			
	Y	RS-485 GND <sup>11)</sup>			
	B	RS-485 B			
	B	RS-485 B			
	PE	Functional earth			
4A	30	PTC1	Input for PTC sensor or thermal switch  Fit jumpers if no PTC sensor or thermal switch is connected.  The terminals must only be connected to voltages of maximum 16 V <sub>rms</sub> and 22.6 V <sub>peak</sub> or 35 VDC.		TM086722
	32	PTC2			
	34	PTC3			
	35	GND, PTC			

Group	Terminal	Designation	Data	Diagram for standard configuration	
3B	16	DI4	Digital input		TM086737
	17	GND			
	18	AO4	Analog output, 0-10 V		
	20	DI5	Digital input		
	21	GND			
	22	AO5	Analog output, 0-10 V		
	24	DI6	Digital input		
	25	GND			
	26	AO6	Analog output		
		42	DI7		
44		DI8	Digital input		
46		DI9			
47		GND			
Fit jumpers instead of the external stops for which the controller is designed.					
4B	36	PTC4			TM086730
	38	PTC5	Input for PTC sensor or thermal switch		
	40	PTC6			
	41	GND, PTC			
Fit jumpers if no PTC sensor or thermal switch is connected.					
The terminals must only be connected to voltages of maximum 16 V <sub>rms</sub> and 22.6 V <sub>peak</sub> or 35 VDC.					
5	82	DO4 NO			TM086739
	83	DO4 C			
	83	DO4 C			
	84	DO5 NO			
	85	DO5 C	Relay contact, NO		
	85	DO5 C	Maximum load: 240 VAC, 2 A		
	86	DO6 NO	Minimum load: 5 VDC, 10 mA		
	87	DO6 C			
	87	DO6 C			
	88	DO7 NO			
89	DO7 C				

11) GND is separated from other earth connections.

F systems, module B2, IO 351, GENIbus number 32

Group	Terminal	Designation	Data	Diagram for standard configuration	
1	L	Phase conductor	1 × 100-240 VAC ± 10 %, 50/60 Hz		TM086700
	L				
	N	Neutral conductor			
	N				
		PE			
2	76	DO1, 2, 3 C	Relay contact, NO Maximum load: 240 VAC, 2 A Minimum load: 5 VDC, 10 mA		TM086720
	76	DO1, 2, 3 C			
	77	DO1 NO			
	79	DO2 NO			
	81	DO3 NO			
3A	10	DI1	Digital input		TM086732
	12	DI2			
	14	DI3			
	15	GND			
The terminals must only be connected to voltages of maximum 16 V <sub>rms</sub> and 22.6 V <sub>peak</sub> or 35 VDC. Fit jumpers instead of the external stops for which the controller is designed.					
3A	53	+24 V	Supply to sensor. Max. 50 mA		TM086703
	55	GND			
	57	AI1	Input for analog signal, 0/4-20 mA or 0-10 V		
	60	AI2			
The terminals must only be connected to voltages of maximum 16 V <sub>rms</sub> and 22.6 V <sub>peak</sub> or 35 VDC.					
3C	A	RS-485 A	GENIbus (internal) (Fix the screen with a cable clamp.)		TM086704
	A	RS-485 A			
	Y	RS-485 GND <sup>12)</sup>			
	Y	RS-485 GND <sup>12)</sup>			
	B	RS-485 B			
	B	RS-485 B			
		Functional earth			
4A	30	PTC1	Input for PTC sensor or thermal switch  Fit jumpers if no PTC sensor or thermal switch is connected.  The terminals must only be connected to voltages of maximum 16 V <sub>rms</sub> and 22.6 V <sub>peak</sub> or 35 VDC.		TM086740
	32	PTC2			
	34	PTC3			
	35	GND, PTC			



Group	Terminal	Designation	Data	Diagram for standard configuration	
3B	16	DI4	Digital input	IO 351 16 17 18 20 21 22 23 24 25 26	TM086741
	17	GND			
	18	AO4	Analog output, 0-10 V		
	20	DI5	Digital input		
	21	GND			
	22	AO5	Analog output, 0-10 V		
	24	DI6	Digital input		
	25	GND			
	26	AO6	Analog output		
		42	DI7		
	44	DI8	Digital input	44	
	46	DI9		46	
	47	GND		47	
4B	36	PTC4	Input for PTC sensor or thermal switch	IO 351 36 38 40 41	TM086730
	38	PTC5			
	40	PTC6			
	41	GND, PTC			
	Fit jumpers if no PTC sensor or thermal switch is connected.				
The terminals must only be connected to voltages of maximum 16 V <sub>rms</sub> and 22.6 V <sub>peak</sub> or 35 VDC.					
5	82	DO4 NO	Relay contact, NO Maximum load: 240 VAC, 2 A Minimum load: 5 VDC, 10 mA	IO 351 - 82 → P4, on/off, VFD 83 ← Common 83 - 84 → P5, on/off, VFD 85 ← Common 85 - 86 → P6, on/off, VFD 87 ← Common 87 - 88 89	TM086742
	83	DO4 C			
	83	DO4 C			
	84	DO5 NO			
	85	DO5 C			
	85	DO5 C			
	86	DO6 NO			
	87	DO6 C			
	87	DO6 C			
	88	DO7 NO			
	89	DO7 C			

12) GND is separated from other earth connections.

S systems, IO 351, GENibus number 31

Group	Terminal	Designation	Data	Diagram for standard configuration	
1	L	Phase conductor	1 × 100-240 VAC ± 10 %, 50/60 Hz		TM086700
	L				
	N	Neutral conductor			
	N				
		PE			
2	76	DO1, 2, 3 C	Relay contact, NO Maximum load: 240 VAC, 2 A Minimum load: 5 VDC, 10 mA		TM086736
	76	DO1, 2, 3 C			
	77	DO1 NO			
	79	DO2 NO			
	81	DO3 NO			
3A	10	DI1	Digital input		TM086721
	12	DI2			
	14	DI3			
	15	GND			
The terminals must only be connected to voltages of maximum 16 V <sub>rms</sub> and 22.6 V <sub>peak</sub> or 35 VDC. Fit jumpers instead of the external stops for which the controller is designed.					
3A	53	+24 V	Supply to sensor. Max. 50 mA		TM086703
	55	GND			
	57	AI1	Input for analog signal, 0/4-20 mA or 0-10 V		
	60	AI2			
The terminals must only be connected to voltages of maximum 16 V <sub>rms</sub> and 22.6 V <sub>peak</sub> or 35 VDC.					
3C	A	RS-485 A	GENibus (internal) (Fix the screen with a cable clamp.)		TM086704
	A	RS-485 A			
	Y	RS-485 GND <sup>13)</sup>			
	Y	RS-485 GND <sup>13)</sup>			
	B	RS-485 B			
	B	RS-485 B			
		Functional earth			
4A	30	PTC1	Input for PTC sensor or thermal switch  Fit jumpers if no PTC sensor or thermal switch is connected.  The terminals must only be connected to voltages of maximum 16 V <sub>rms</sub> and 22.6 V <sub>peak</sub> or 35 VDC.		TM086722
	32	PTC2			
	34	PTC3			
	35	GND, PTC			

Group	Terminal	Designation	Data	Diagram for standard configuration	
3B	16	DI4	Digital input		TM086741
	17	GND			
	18	AO4	Analog output, 0-10 V		
	20	DI5	Digital input		
	21	GND			
	22	AO5	Analog output, 0-10 V		
	24	DI6	Digital input		
	25	GND			
	26	AO6	Analog output		
		42	DI7		
44		DI8	Digital input		
46		DI9			
47		GND			
Fit jumpers instead of the external stops for which the controller is designed.					
4B	36	PTC4			TM086725
	38	PTC5	Input for PTC sensor or thermal switch		
	40	PTC6			
	41	GND, PTC			
Fit jumpers if no PTC sensor or thermal switch is connected.					
The terminals must only be connected to voltages of maximum 16 V <sub>rms</sub> and 22.6 V <sub>peak</sub> or 35 VDC.					
5	82	DO4 NO			TM086743
	83	DO4 C			
	83	DO4 C			
	84	DO5 NO			
	85	DO5 C	Relay contact, NO		
	85	DO5 C	Maximum load: 240 VAC, 2 A		
	86	DO6 NO	Minimum load: 5 VDC, 10 mA		
	87	DO6 C			
	87	DO6 C			
	88	DO7 NO			
89	DO7 C				

<sup>13)</sup> GND is separated from other earth connections.

#### 4.2.6 CU 352 and IO 351 installation and operating instructions

See Grundfos Product Center for the CU 352 or IO 351 installation and operating instructions.

## 5. Fault correction tools

### 5.1 MPC/CU 352 indicator lights and alarm relay

See Grundfos Product Center for CU 352 or IO 351 installation and operating instructions.

### 5.2 MPC display

#### 5.2.1 Status (1)

This display is shown when the power is switched on, and it appears if the buttons of the control panel remain untouched for 15 minutes.

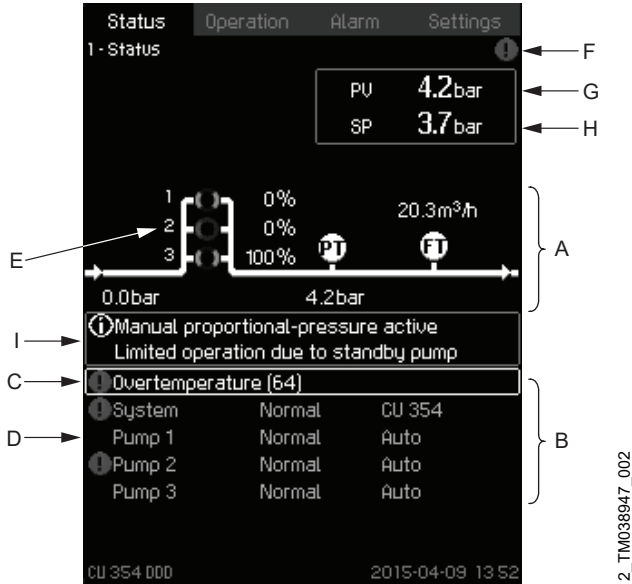

2\_TMO38947\_002

#### Status

##### Description

No settings can be made in this menu.

The actual value (process value, PV) of the control parameter, usually the outlet pressure, is shown in the upper right corner (G) together with the selected setpoint (SP) (H).

The upper half of the display (A) shows a graphic illustration of the system. The selected measuring parameters are shown with sensor symbol and actual value.

In MPC-E systems where the differential pressure across the pumps and pump curve data are known, the display shows the estimated flow rate when the flow rate and speed of the pumps are within a range where it is possible to estimate the flow rate.

≈ : This indicates that the flow rate is an estimated value.



The estimated flow rate may differ from a measured value.

In the middle of the display, an information field (I) is shown if any of the following events occurs:

- Limited operation due to standby pump
- Proportional-pressure influence active
- External setpoint influence active
- Alternative setpoint active
- Low flow boost active
- Pressure relief active
- Clock program active
- Remote-controlled via GENI (RS-485)
- Limited due to reduced operation
- Stopped due to low flow.

The lower display half (B) shows the following:

- the most recent active alarm, if any, and the fault cause with the fault code in brackets

- system status with actual operating mode and control source
- pump status with actual operating mode.



If a fault has occurred, the warning symbol  $\triangle$  or alarm symbol  $\otimes$  is shown in the line (C) together with the cause and fault code, for instance "Overtemperature (64)".

If the fault is related to one of the pumps, one of the symbols  $\triangle$  or  $\otimes$  is also shown in front of the status line (D) of the pump in question. At the same time, the pump status indicator (E) changes colour to either yellow or red as described in the table below. The symbol  $\triangle$  or  $\otimes$  is shown to the right in the top line of the display (F). As long as a fault is present, this symbol is shown in the top line of all displays.

To open a menu line, select the line with [V] or [A] and press [OK].

The display allows you to open status displays showing the following:

- actual alarms
- system status
- status of each pump.

#### Description of pump status

Pump status indicator	Description
Rotating, green	The pump is running.
Permanently green	The pump is ready (not running).
Rotating, yellow	Warning. The pump is running.
Permanently yellow	Warning. The pump is ready (not running).
Permanently red	Alarm. The pump is stopped.

#### 5.2.2 Alarm log (3.2)

The alarm log can store up to 24 warnings and alarms.

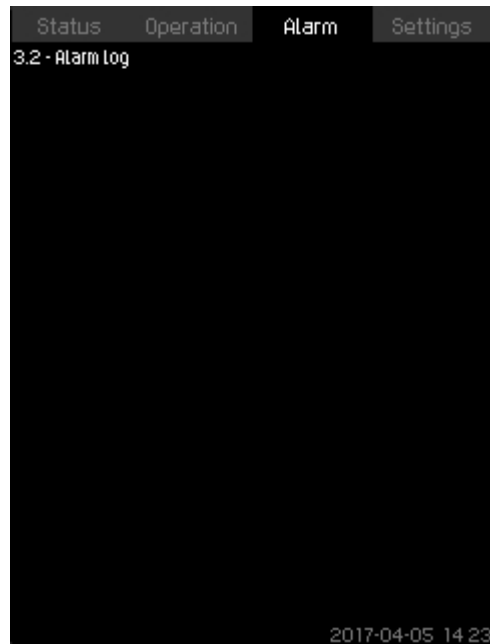

3-2\_TMO32292\_080

#### Alarm log

##### Description

The display shows warnings and alarms.

For every warning or alarm, the following is shown:

- Whether it is a warning  $\triangle$  or an alarm  $\otimes$ .
- Where the fault occurred: **System, Pump 1, Pump 2**, etc.
- In case of input-related faults, the input is shown.
- The cause of the fault and the alarm code in brackets, such as "Water shortage (214)".
- When the fault occurred: **Date and time**.
- When the fault disappeared: **Date and time**. If the fault still exists, date and time are shown as "--:--:--".

The most recent warning or alarm is shown at the top of the display.

### 5.2.3 Passwords

Passwords can be set to prevent unauthorised change of settings in the menus **Operation** and **Settings**.

See the Hydro MPC installation and operating instructions.

Both passwords are disabled. If a password is enabled, the factory setting is **1234**.

### Service passwords

If a customer password is set and not available for a Grundfos service engineer, the system can be unlocked by using the Grundfos service code **6814**. Protect this code and avoid unauthorised use of the code.

### 5.2.4 Alarm list

Check all active alarm codes before starting the fault correction.

MPC alarm indication Protocol description	Alarm code	Associated device and device number	Description/cause	Remedy	Reset type <sup>14)</sup>	Alarm/warning Action type <sup>15)</sup>
Phase failure, pump	2	Pump 1-6	-	Check that all three mains phases are within a 15 V band.	Auto	Warning
Too many restarts	7	Pump 1-6	HSD = hardware shut-down. There has been a fault, and the permissible number of restarts for the fault type has been exceeded. Fault in mains supply. Terminal box defective.	Restore mains supply. Replace terminal box.	Auto	Warning
Undervoltage, pump	40	Pump 1-6	Mains voltage is too low at start.	Bring voltage back to prescribed level.	Auto	Warning
Undervoltage, pump	42	Pump 1-6	Faulty mains supply at the time of cutting in the terminal box.	Restore correct mains supply.	Auto	Warning
Undervoltage, pump	73	Pump 1-6	Fall in mains supply. Mains supply failure while motor is running.	Restore correct mains supply.	Auto	Warning
Overvoltage, pump	32	Pump 1-6	Mains voltage is too high at start.	Bring voltage back to prescribed level.	Auto	Warning
Overload, associated device	48	Pump 1-6	Heavy overload has caused software shut-down (SSD).	Check and possibly reduce the load.	Auto	Warning
Overload, associated device	50	Pump 1-6	MPF = motor protection function. The built-in motor protection has detected a sustained overload (MPF 60 sec. limit).	Check and possibly reduce load or improve cooling.	Auto	Warning
Overload, associated device	51	Pump 1-6	Heavy overload ( $I_{max}$ . very high). Pump blocked at start.	Deblock the pump.	Auto	Warning
Overload, associated device	54	Pump 1-6	The built-in motor protection has detected a transitory overload (MPF 3 sec. limit).	Check and possibly reduce load or improve cooling.	Auto	Warning
Too high motor temperature	65, 70	Pump 1-6	PTC sensor in the motor has signalled overtemperature.	Check and possibly reduce load or improve cooling.	Auto	Warning
Too high motor temperature	67	Pump 1-6	The terminal box has indicated overtemperature.	Check and possibly reduce load or improve cooling. Temperature during operation can be read via PC Tool E-products.	Auto	Warning
Other fault, associated device	76	Pump 1-6	Internal communication fault has occurred in the pump.	Try to reset the fault: Switch off the power supply. Wait until all diodes are out. Switch on the power supply. If this does not remedy the fault, replace the terminal box.	Auto	Warning

MPC alarm indication	Alarm code	Associated device and device number	Description/cause	Remedy	Reset type <sup>14)</sup>	Alarm/warning
Protocol description						Action type <sup>15)</sup>
Limit 1 exceeded	190	Measured parameter	The measured parameter has exceeded the limit set.	Remove the cause of the fault.	Man/ auto	Alarm/warning Stop/unchanged
Limit 2 exceeded	191	Measured parameter	The measured parameter has exceeded the limit set.	Remove the cause of the fault.	Man/ auto	Alarm/warning Stop/unchanged
Pressure relief	219	System	The monitored pressure could not be reduced sufficiently.	Reduce the pressure to below the limit.	Auto	Warning Unchanged
Pressure build-up fault	215	System	The pressure set cannot be reached within the configured time.	Check limit and pipes.	Man/ auto	Alarm/warning Stop/unchanged
Pumps outside duty range	208	System	The pump is running outside the defined range.	Check the system.	Man/ auto	Warning Unchanged
Pilot pump fault	216	Pilot pump	Pilot pump fault.	Check wires. Check the pump.	Auto	Warning
Water shortage Water shortage <sup>16)</sup>	206		The precharge pressure (or the level in the feed tank) is below its programmable warning limit.		Man/ auto	Warning Unchanged
Water shortage Water shortage <sup>16)</sup>	214		The precharge pressure (or the level in the feed tank) is below its programmable alarm limit.	Check the actual pressure and the corresponding settings.	Man/ auto	Alarm Stop
			The pressure switch detects water shortage.	Check the sensor/switch, wiring and input according to the wiring diagram.		Warning Unchanged
Pressure high Pressure above maximum pressure <sup>16)</sup>	210		The operating pressure is above the programmable high-pressure alarm limit.	Check the sensor/switch.	Man/ auto	Alarm Fast stop (overrides min. seq. time)
Pressure low Pressure below min. pressure <sup>16)</sup>	211	Booster system	The operating pressure is below the programmable low-pressure alarm limit.		Man/ auto	Alarm/warning Stop/unchanged
Alarm, all pumps Alarm, all pumps <sup>16)</sup>	203		All pumps set to Auto have stopped due to a pump alarm.	Fault-find according to the alarm message/code: System. Pumps installed. Use fault-finding for the pump.	Auto	Alarm
			Pumps are not indicating alarm.	Check the GENIbus wires, for instance connection and polarity.		Stop
External fault External fault <sup>16)</sup>	003		The digital input set to <b>External fault</b> has been or is still closed.	The fault reading can be reset with the Grundfos GO when the digital input is no longer closed. Reset by pressing [+] or [-].	Man/ auto	Alarm/warning Stop/unchanged
Dissimilar sensor signals Dissimilar sensor signals <sup>16)</sup>	204	Primary sensor and/or redundant sensor	Primary feedback sensor value (pressure) is inconsistent with redundant feedback sensor value.	Check the wiring and input according to the wiring diagram. Check the sensor output according to the value measured.	Auto	Warning Unchanged
Fault, primary sensor Closed-loop feedback sensor signal fault <sup>16)</sup>	089	Primary sensor	A fault in the sensor assigned to the feedback control has been detected.	Check the wiring and input according to the wiring diagram. Check the sensor output according to the value measured.	Auto	Alarm
			Fault in the settings of the sensor assigned to the controller.	Check the settings of the primary sensor.		Stop

MPC alarm indication	Alarm code	Associated device and device number	Description/cause	Remedy	Reset type <sup>14)</sup>	Alarm/warning
Protocol description						Action type <sup>15)</sup>
Fault, sensor General (measurement) sensor signal fault <sup>16)</sup>	088	CU 352 IO 351B as IO module	The signal, for instance 4 to 20 mA, from one of the analog sensors is outside the selected signal range.	Check the wiring and input according to the wiring diagram. Check the sensor output according to the value measured.	Auto	Warning Unchanged
Internal fault, CU 352 Real-time clock out of order <sup>16)</sup>	157		The real-time clock in the CU 352 is out of order.	Replace the CU 352.		Warning
Fault, Ethernet Ethernet: No address from DHCP server <sup>16)</sup>	231		No address from DHCP server.	Communication fault. Contact the system integrator.		
Fault, Ethernet Ethernet: Auto-disabled due to misuse <sup>16)</sup>	232	CU 352	Auto-disabled due to misuse.		Auto	Unchanged
FLASH parameter verification error FLASH parameter verification error <sup>16)</sup>	083		Verification error in the CU 352 FLASH memory.	Replace the CU 352.		
Other fault, associated device	83		Setting data not correct.	Other fault, associated device.		Warning
IO 351 internal fault Hardware fault, type 2 <sup>16)</sup>	080	IO 351	Hardware fault in the IO 351A. Hardware fault in the IO 351B.	See <b>Actual alarms</b> , and identify the faulty IO 351 module from the alarm message. Replace the module.	Auto	Warning Unchanged
VFD not ready VFD not ready <sup>16)</sup>	213	Pump 1-6 CU 352	The VFD signal relay does not release the VFD for operation.	Check for VFD alarm. Check the wiring and input according to the wiring diagram.	Auto	Warning Unchanged
Communication fault Pump communication fault <sup>16)</sup>	010	Pump 1-6 IO 351	No GENIbus communication with a device connected to the CU 352.	See <b>Actual alarms</b> , and identify the faulty device from the alarm message. Check the power supply. Check the GENIbus cable connection. Check that the GENIbus number of the device is correct, using the Grundfos GO.	Auto	Warning Unchanged
Device alarms	From device	Pump 1-6	The device is in alarm condition.	See <b>Actual alarms</b> and identify the faulty device from the alarm message. Fault-find according to the service instructions for the device.	Auto	Warning Unchanged

<sup>14)</sup> Reset either of these types:

- **Auto acknowledgement** (automatic).
- **Auto acknowledgement** or **Manual acknowledgement** (automatic/manual).

<sup>15)</sup> System goes to operating mode **Stop** (no delay (< 0.5 s) between pump disconnections).

<sup>16)</sup> Protocol description.

### 5.3 Grundfos GO

The Grundfos GO can be used for setting the addresses of the IO 351 modules and for reading out settings. The general-purpose IO module inputs and outputs are set up via the CU 352 or with a PC Tool connected via the CU 352.

### 5.4 PC Tool E-products

The Grundfos PC Tool E-products supports the system and the components included. A detailed PC Tool Help assistant is available in the tool program, and a user manual in PDF format can be printed from the tool. The tool can be connected to the CU 352 of the system and communicate with IO modules and E-pumps. The **Network list** of the tool shows the units which are capable of communicating with the application in question.

The tool supports these functions:

- network list
- monitor
- standard configuration
- custom configuration
- data logging
- updating configuration files.

#### 5.4.1 Network list

This is a list of all GENIbus products connected to the network. Clicking **Network list** in the toolbar allows you to toggle between the network list expanded and collapsed.

#### 5.4.2 Monitor

This function gives an overview and details of the operating status of the system.

#### Output

If the expected output function does not take place according to the graphical presentation, it may be due to the following faults:

- Defective component connected to the output. Check the component according to the wiring diagram.
- The output from the IO module does not function according to the graphical presentation. Check the physical output.

#### Input

If the expected input function does not take place according to the graphical presentation, it may be due to the following faults:

- The input signal is not as shown in the graphical presentation. Check that the signal is OK on the input terminal.
- The input of the IO module is defective. Replace the IO module.
- The CU 352 is defective.

#### 5.4.3 Standard configuration

The standard configuration function allows you to select the appropriate standard configuration file for the system and send the file to the system.

It is possible to import a Grundfos Standard Configuration (GSC) file library via Tools > Update configuration files.

From factory, the system is configured/programmed for the application.

If an IO module is replaced, the new module will automatically be configured from the CU 352 when the system is restarted.

Remember to give the new module the correct GENIbus address by means of the Grundfos GO.

If replaced, a CU 352 must be configured to the application in question. Follow the instructions in the **Help assistant**.

Standard configuration files are included in the tool when it is installed for the first time.

Subsequently, it is the user's responsibility to download the current version of the **Standard configuration file library**. See section Updating configuration files.

#### Related information

[5.4.6 Updating configuration files](#)

### 5.4.4 Custom configuration

The custom configuration function enables you to change selected standard configuration settings to a custom configuration.

Custom configuration should be considered as an expert tool to be used for changing/adjusting standard data.

### 5.4.5 Data logging

Data logging of all data takes place continuously. In the network list, you can select the data to be visible. When the PC Tool is shut down, you will be asked whether you want to save your data log.

### 5.4.6 Updating configuration files

You can import an updated library of the standard configuration files from Tools > Update configuration files. You will get the option to choose the update method: browse for a zip-file or automatic (requires access to internet).

## 6. Configuration of Hydro MPC

### 6.1 Necessary equipment

The following equipment is required:

- Grundfos GO
- PC Tool E-products.

#### Related information

[6.2.1 Setting the GENIbus number in IO 351 modules, if any](#)

[6.2.2 Configuration of CU 352](#)

[6.2.3 Configuration of external frequency converters, if any](#)

[6.2.4 Step-by-step configuration of E-pumps, if any](#)

### 6.2 Factory configuration of Hydro MPC

To do the configuration, follow the below steps:

1. Set the GENIbus number in IO 351 modules, if any.
2. Configure CU 352.
3. Configure the external frequency converters, if any.
4. Configure the E-pump(s) step-by-step, if any.

#### 6.2.1 Setting the GENIbus number in IO 351 modules, if any

Depending on the Control MPC system type and Control MPC options, the control panel is equipped with none or up to four IO 351A/B modules.

The modules present will have the designation numbers A1, A2, A01 or A03.

The units must have a GENIbus number according to the table below.

Module with designation	Address of module	Control MPC option GSC file to download
IO 351B interface	41	98272072
IO interface	42	98272073
Operating lights	41	98272076
Interface and operating lights	41 + 42	98272077
Pressure relief	41	98272079
Interface and pressure relief	41 + 42	98272081

To assign GENIbus numbers to the IO 351 module(s), if any, proceed as follows:

1. Switch on the power supply to the Control MPC.
2. Switch on the Grundfos GO with MI 301 and point it at the IR window of the first IO 351 to make contact with this module.



If there is more than one IO 351, move close to the IR window to make sure that only one module is communicating with the Grundfos GO at a time.





IR window of the IO 351

- For Grundfos GO, go to the **Settings > NUMBER** display. Set the address of the module according to the table above.

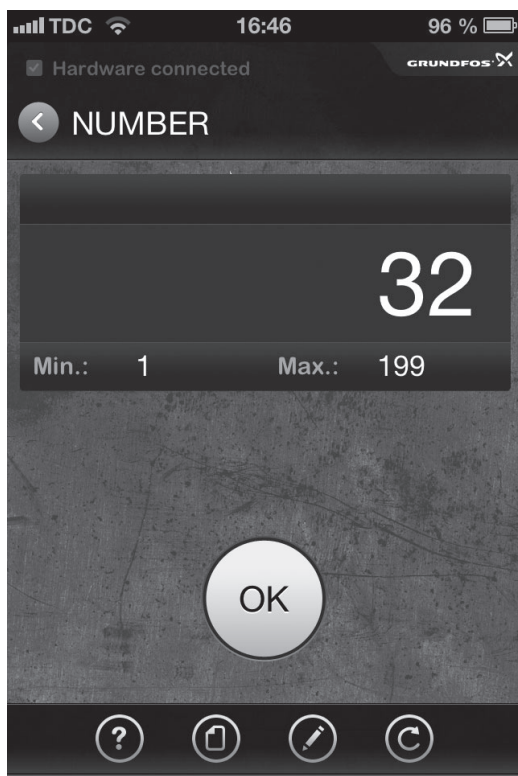

Grundfos GO

- Send the number to the unit by pressing **OK** on the Grundfos GO.
- Switch off Grundfos GO.
- Repeat steps 2 to 4 for each IO 351 module.

TM039972

TM054667

### 6.2.2 Configuration of CU 352

To make the system work properly, CU 352 in the Control MPC must be configured with a number of GSC (Grundfos Standard Configuration) files.

- Control MPC requires a **Control MPC GSC file** which includes information about the system type in question (E, ES, ED, etc.) and the number of main pumps in the system.
- Control MPC based on one or two IO 351B modules with the designation numbers A01 and A03 requires a **Control MPC options - GSC file**.
- Hydro MPC requires a Hydro MPC GSC file describing the outlet pressure, sensor range and dry-running protection type.
- Hydro MPC fitted with a redundant primary sensor requires a **Hydro MPC options - GSC file**.
- Hydro MPC requires a **Pump data GSC file** describing the performance curve of the pump in question. If a pilot pump is connected, a file describing the performance curve of the pilot pump in question must be loaded.

Note the right order of configuration:

- Control MPC
- Control MPC options
- Hydro MPC
- Hydro MPC options
- Pump data
- Pilot pump data, if any
- Service contact information, if any.

#### Configuration of Control MPC

Example: Hydro MPC-ES with three pumps CRIE 5-8.

Control MPC has two options, "Interface I/O module" and "Operating lights module".

Hydro MPC has one option, "Redundant sensor, 16 bar".

The printed label of GSC files will look like this:

1	1. Control MPC	3. Hydro MPC	3
2	2. C-MPC options	4. H-MPC options	5
		5. Pump data	4

CONFIGURATION STEPS - PLEASE FOLLOW THE NUMBERS 96586126

TM031742

Example of a printed label of GSC files

Pos.	Description
1	96307032
2	96592488
3	96307209
4	96592497
5	96307221



After the last GSC file download (if no further configurations are to be made), restart CU 352 by clicking **Restart** in the right bottom of the PC Tool.

When you click **Restart**, CU 352 will initialise. This procedure takes about 25 seconds.

Step-by-step configuration of Control MPC:

- Set all automatic circuit breakers covering the pumps to off.

2. Connect the PC Tool to the service connection (TTL port) or USB connection on CU 352.

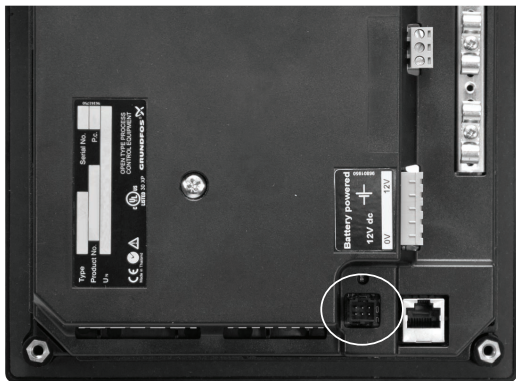

Service connection (TTL)



USB connection

3. Switch on the power supply to the Control MPC.
4. Start the PC Tool E-products.
5. When communication has been established, the PC Tool **Network list** will display the icons for CU 352 and the IO 351 module(s), if any.
6. Select CU 352 in the **Network list**.
7. Select the PC Tool function **Standard configuration**. [F6].
8. Select **Application** in **Search by**.

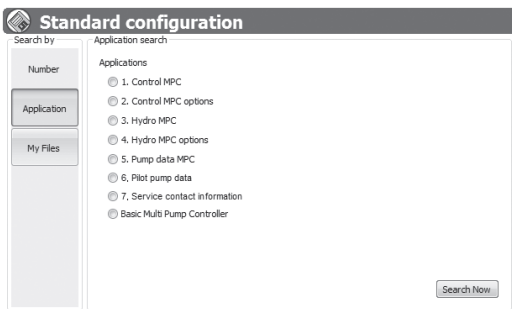

9. Click the required application.

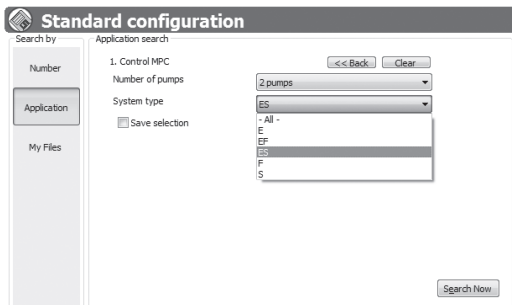

10. From the drop-down menus, select the configuration of the current application.
11. When the selection has been made, click **Search Now** and the configuration file will appear.

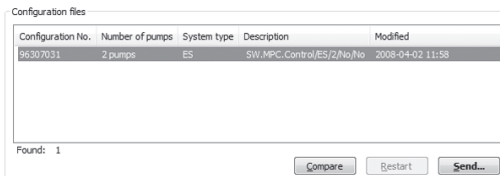

12. A configuration file is now available as a result of the previous selections. In the **Configuration files** field, details on the configuration files can be found. Make sure that these details are correct and apply to the system.

13. Select the file from the **Configuration files** field and click **Send**.

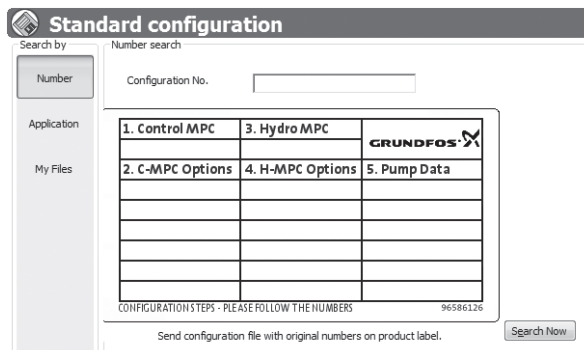

14. Select **Number** in **Search by**.

15. Check that the selected configuration file number is now shown in the label under **1. Control MPC**. This indicates that CU 352 has received and stored the GSC file.

Follow the procedure described above to find and send the configuration files for the remaining applications:

- Control MPC options
- Hydro MPC
- Hydro MPC options
- Pump data
- Pilot pump data, if available
- Service contact information, if available.

If no further configurations are to be made, restart CU 352 by clicking **Restart** in the right bottom of the PC Tool.

### 6.2.3 Configuration of external frequency converters, if any

The manufacturer's factory settings of the external frequency converter(s) used in Hydro MPC F, EF and EDF must be changed to the Grundfos settings before the system is ready for test.

To configure the external frequency converter:

1. Switch on the power supply to the frequency converter(s) by means of the automatic circuit breaker.
2. For each frequency converter, make the settings as described in the table below.

#### VLT 2800

Press **QUICK MENU** and **+** to access all parameters.

Parameter	Function	Factory setting		Function	Grundfos setting	
		Value or number in display of VLT			Value or number in display of VLT	
		Value	Number of function		Value	Number of function
001	Language	English	[0]	Language	_ <sup>17)</sup>	-
101	Torque characteristic	Constant torque	[1]	Torque characteristic	Variable torque low	[2]
					Variable torque medium	[3]
102	Motor power	-	-	Motor power	_ <sup>18)</sup>	-
103	Motor voltage	230/400 V	-	Motor voltage	_ <sup>18)</sup>	-
104	Motor frequency	50 Hz	-	Motor frequency	_ <sup>18)</sup>	-
105	Motor current	-	-	Motor current	_ <sup>18)</sup>	-
106	Rated motor speed	-	-	Rated motor speed	_ <sup>18)</sup>	-
128	Thermal motor protection	No protection <sup>19)</sup>	[0]	Thermal motor protection	Thermistor trip, LC filter connected <sup>19)</sup>	[2]
					No thermal protection, LC filter not connected <sup>19)</sup>	[0]
136	Slip compensation	100 %	-	Slip compensation	0 %	-
202	Output frequency high limit	132 Hz	-	Output frequency high limit	_ <sup>20)</sup>	-
205	Maximum reference	50 Hz	-	Maximum reference	_ <sup>20)</sup>	-
207	Ramp-up time 1	3 sec.	-	Ramp-up time 1	1 sec.	-
208	Ramp-down time 1	3 sec.	-	Ramp-down time 1	1 sec.	-
303	Digital input 19	Reversing	[9]	Digital input 19	Thermistor, LC filter connected <sup>19)</sup>	[25]
					No function, LC filter not connected <sup>19)</sup>	[0]
405	Reset function	Manual reset	[0]	Reset function	Auto reset x 10	[10]
412	Variable switching frequency	Without LC filter	[2]	Variable switching frequency	LC filter connected	[3]
					Without LC filter	[2]

<sup>17)</sup> For information about languages available, see relevant documentation.

<sup>18)</sup> Use data from the system.

<sup>19)</sup> Thermistor function used for thermal protection of LC filter.

<sup>20)</sup> 51 Hz for a 50 Hz supply and 61 Hz for a 60 Hz supply.

#### Factory settings of VLT 2800

To recall the factory settings of all parameters, follow the procedure below:

1. Disconnect the power supply.
2. Press and hold **QUICK MENU**, **+** and **CHANGE DATA** and reconnect the power supply.
3. All parameters are now reset to the factory setting, except the fault log.

**VLT 6000**

Press **EXTEND MENU** to access all parameters.

Parameter	Function	Factory setting		Function	Grundfos setting	
		Value or number in display of VLT			Value or number in display of VLT	
		Value	Number of function		Value	Number of function
001	Language	-	-	Language	_21)	-
102	Motor power	-	-	Motor power	_22)	-
103	Motor voltage	-	-	Motor voltage	_22)	-
104	Frequency	50 Hz	-	Frequency	_22)	-
105	Motor current	-	-	Motor current	_22)	-
106	Rated motor speed	-	-	Rated motor speed	_22)	-
117	ETR trip1	-	4	Thermistor trip, LC filter connected <sup>23)</sup>	-	2
				No thermal protection, LC filter not connected <sup>23)</sup>	-	0
202	Maximum frequency	50 Hz	-	Maximum frequency	_24)	-
205	Maximum reference frequency	50 Hz	-	Maximum reference frequency	_24)	-
206	Ramp-up time	-	-	Ramp-up time	1 sec.	-
207	Ramp-down time	-	-	Ramp-down time	1 sec.	-
303	Reverse	-	1	No function	-	0
323	Alarm	-	8	Ready	-	1
400	Manual reset	-	0	Auto reset x 10	-	6
408	ASFM, adjustable switching frequency modulation	-	0	LC filter connected	-	2
				LC filter not connected	-	0

21) For information about languages available, see relevant documentation.

22) Use data from the system.

23) Thermistor function used for thermal protection of LC/RFI filter.

24) 51 Hz for a 50 Hz supply and 61 Hz for a 60 Hz supply.

**Factory settings of VLT 6000**

To recall the factory settings of all parameters, follow one of the procedures below:

**Procedure 1**

1. Set parameter 620 to (3).
2. Disconnect the power supply.
3. Reconnect the power supply.
4. All parameters are now reset to the factory setting, except the fault log.

**Procedure 2**

1. Disconnect the power supply.
2. Press and hold **DISPLAY MODE**, **CHANGE DATA** and **OK** and reconnect the power supply.
3. All parameters are now reset to the factory setting, except the fault log.

**VLT FC 100**

Press **EXTEND MENU** to access all parameters.

Parameter	Factory setting				Grundfos setting	
	Function	Value or number in display of VLT		Function	Value or number in display of VLT	
		Value	Number of function		Value	Number of function
001	Language	English	[0]	Language	_ 25)	-
002	Motor speed unit	RPM	[0]	Motor speed unit	Hz	[1]
120	Motor power	-	-	Motor power	_ 26)	-
122	Motor voltage	-	-	Motor voltage	_ 26)	-
123	Motor frequency	50 Hz	-	Motor frequency	_ 26)	-
124	Motor current	-	-	Motor current	_ 26)	-
125	Rated motor speed	1460 RPM	-	Rated motor speed	_ 26)	-
190	Motor thermal protection	ETR trip 1	[4]	Thermistor trip, LC filter connected <sup>27)</sup>	Thermistor trip	[2]
				No thermal protection, LC filter not connected <sup>27)</sup>	No protection	[0]
419	Maximum output frequency	100 Hz		Maximum output frequency	51 Hz	-
303	Maximum reference	50 Hz		Maximum reference	_ 28)	-
341	Ramp 1 ramp-up time	-	-	Ramp 1 ramp-up time	1 sec.	-
342	Ramp 1 ramp-down time	-	-	Ramp 1 ramp-down time	1 sec.	-
511	Digital input 19	Reversing	[10]	No operation	-	[0]
540	Relay 1	Alarm	[9]	Relay 1	Drive ready	[2]
	Relay 2	Running	[5]	Relay 2	Control ready	[1]
1420	Reset mode	Manual reset	[0]	Auto reset x 10	-	[10]
1401	Switching frequency	4.0 Hz	[6]	Switching frequency	5.0 Hz	[7]
					-	

25) For information about languages available, see relevant documentation.

26) Use data from the system.

27) Thermistor function used for thermal protection of LC/RFI filter.

28) 51 Hz for a 50 Hz supply and 61 Hz for a 60 Hz supply.

**Factory setting of VLT FC 100**

To recall the factory settings of all parameters, follow one of the procedures below:

**Procedure 1**

1. Set parameter 14-22.
2. Press **OK**.
3. Select **Initialisation** (for NLCP select **2**).
4. Press **OK**.
5. Disconnect the power supply.
6. Reconnect the power supply.
7. All parameters are now reset to the factory setting, expect RFI 1, protocol, address, baud rate, minimum response delay, maximum response delay, maximum inter.char delay, operating data, historic log and fault log.

**Procedure 2**

1. Disconnect the power supply.
2. Press and hold **STATUS**, **MAIN MENU** and **OK** and reconnect the power supply.
3. All parameters are now reset to the factory setting, expect the number of operating hours, power-ons and overtemperature and overvoltage faults.

### 6.2.4 Step-by-step configuration of E-pumps, if any

Before the system is ready for test, the E-pumps have to be set.

1. Switch on the power supply to the E-pumps by means of the automatic circuit breaker.
2. Set the GENIbus number to the same number as that of the pump using Grundfos GO.  
(Number = 1 for pump No 1, etc. Pilot pumps are set to GENIbus number 10.)



Pumps are numbered from left to right.



Pumps numbered from left to right

Pos.	Description
1	Pump 1
2	Pump 2

After the GSC file is downloaded, the configuration of each pump must be done by either PC Tool E-products (model C, D, F, G) or PC Tool Go Link (model H, I, J, K).

1. Connect the PC Tool to the pump you want to configure.
2. Select the PC Tool function **Standard configuration**.
3. Go to section **Search by** and select **Number**.
4. Find the relevant GSC file number from the table below.
5. Enter the GSC file number in the **Configuration No** field and click **Search Now**.
6. Select the file from the field **Configuration files** and click **Send**.
7. Repeat the steps for each E-pump.

#### GSC file number

Application	GSC file number
MGE 1-ph HM2MKII (model C)	95139670
MGE 3-ph HM3MKII (model D)	95139671
MGE 3-ph HMLarge (model F)	95139672
MGE 3-ph HM3MK11 (model G)	97913788
MGE 3-ph/1-ph (model H, I, J) <sup>29)</sup>	98428069
MGE 3-ph/1-ph (Model H, I, J) <sup>30)</sup>	98428068
MGE 3-ph (model H, I, J, K with FM 310) <sup>29)</sup>	93028557
MGE 3-ph (model H, I, J, K with FM 310) <sup>31)</sup>	93145316

<sup>29)</sup> For MPC-E 3600 rpm & MPC-ED/ES 60 Hz.

<sup>30)</sup> For MPC-E 3000 rpm & MPC-ED/ES 50 Hz.

<sup>31)</sup> For MPC-E 3000 rpm & MPC-ED/ES 60 Hz.

### Exchanging motors or pumps in existing systems

In service-related cases where there is a need to exchange either a motor or a complete pump, make sure that the pumps perform as equally as possible as they run synchronously.

If not compensated, in the worst case, the pump with the lowest pressure can heat up as it cannot overcome the system pressure and might be damaged.

**Example:** the original system is equipped with CRE 90-1, the system operates with a setpoint equal to the pump's nominal duty point. See below image.

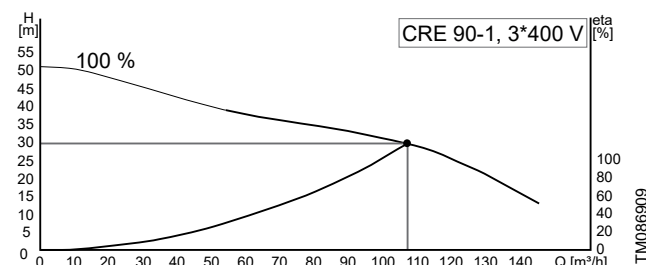

As CRE 90-1 is discontinued, the replacement pump will be CRE 95-1. This pump has a better performance and can achieve the same performance as CRE 90-1 when operating at 95 % speed.

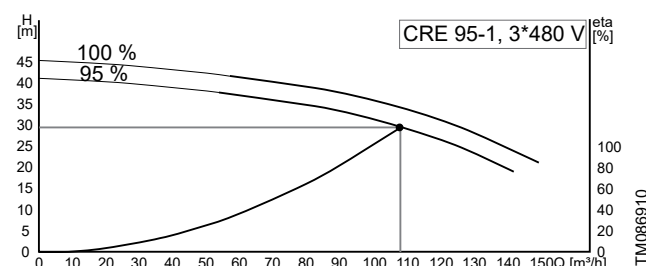

In this case, the maximum speed of the new pump must be set to 95 % speed.

### Exchange from model F to model K

The model F motor is discontinued and can be exchanged with the permanent magnet motor model K. Implementation of the new motor does not have any impact in the production or in systems where all the motor types are the same. In service-related cases where we use both model F and model K, additional GSC files must be downloaded to introduce a "false" slip.

The model F motors run with a slip, as they are asynchronous motors. (Slip is the difference between the synchronous speed and asynchronous speed of an electrical induction motor). The model K, in combination with CRE, runs without slip by default, so the maximum speed is slightly higher on model K compared to model F, thereby achieving a better performance.

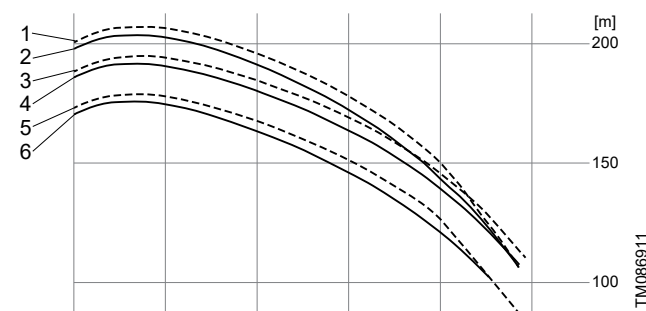

Example

Pos.	Description
1	CRE 32-7, 22 kW, model K
2	CRE 32-7, 22 kW, model F
3	CRE 32-7-2, 22 kW, model K
4	CRE 32-7-2, 22 kW, model F
5	CRE 32-6, 18.5 kW, model K
6	CRE 32-6, 18.5 kW, model F

## Exchange from model H, I, J with FM 300 to model H, I, J with FM 310

Type: MGE310.4 F185-A	PC: 3223	INPUT	OUTPUT	Variant
DN: 99200112 v14501	Branch Fuse Max: 32A	U in:	P2: 0.250 kW	IP: 311
DE: 6204.272.C3	Env Type: 3	IP: S5 3 ~	n: 1450-2000 rpm	FM: 310
IND: 6204.272.C3	PF: 0.58-0.52	CL F	IPDS Eff <sub>max</sub> : 84.5%	IPDS: 300
WEG: 30.001.1.2.1	I <sub>max</sub> : 50 A	U <sub>2</sub> : 0.85-0.70 A	COM:	

TM086936

When the first models H, I, J permanent magnet motors are released (with FM 300), they are implemented with a “false” slip to be able to compare and mix with standard asynchronous motors. With the upgrade of model H, I, J to functional module FM 310, (with Bluetooth connectivity and Safe Torque Off (STO)), the CR small and medium range extends the maximum speed to 4000 rpm without slip, the CR large range continues with 3600 rpm, but now without slip.

The systems with CU 352 though continues with 3600 rpm on CR small and medium with slip (no change, use the standard GSC files). The CR large standard range also continues with 3600 rpm, but now without slip. Again, this does not have any impact if the system has the same motor type on all pumps, but in service-related cases with mixed motor versions, we have the same challenge as described with model F and K.

### Remedy:

To avoid the difference in performance with mixed motor models on CR large (3600 rpm), an additional GSC file must be downloaded to the new model motor. This introduces a false slip so the new model motor can perform like a motor with slip (model F and H, I, J with FM 300).

The file depends on the kW size of the motor.

After exchanging a motor or a complete pump, use the Go Link PC-Tool to download the different GSC files, starting with:

1. the correct pump GSC file (if only the motor is exchanged, it is already in a complete pump)
2. the MPC GSC file in above section
3. the “slip” file according to the table below.

Application	GSC file number
MGE 3-ph (model H, I, J, K) include slip 15 kW	93028570
MGE 3-ph (model H, I, J, K) include slip 18.5 kW	93028573
MGE 3-ph (model H, I, J, K) include slip 22 kW	93028578
MGE 3-ph (model H, I, J, K) include slip 11 kW	93145288
MGE 3-ph (model H, I, J, K) include slip 7.5 kW	93145289
MGE 3-ph (model H, I, J, K) include slip 5.5 kW	93145310
MGE 3-ph (model H, I, J, K) include slip 4 kW	93145311
MGE 3-ph (model H, I, J, K) include slip 3 kW	93145312
MGE 3-ph (model H, I, J, K) include slip 2.2 kW	93145313
MGE 3-ph (model H, I, J, K) include slip 1.1 kW	93145314
MGE 3-ph (model H, I, J, K) include slip 0.75 kW	93145315

The GSC file number is hidden, and you can only see the original pump GSC file when you connect the pump to the PC Tool.



- The firmware version for CU 352 must be V05.03.00 or newer to recognise model K.
- The correct GENI address can be set with either Go Link or Grundfos GO.

### Configuration of the CUE, if any

The manufacturer's factory settings of the CUE used in Control MPC must be changed to the Control MPC settings before it is ready to test.

To configure the CUE:

1. Switch off the power supply to the CUE by means of the automatic circuit breaker.
2. Connect the PC Tool to the GENIbus terminals of the CUE which you want to configure.
3. Switch on the power supply to the CUE.
4. Start the PC Tool E-products.

5. When communication is established, the PC Tool **Network list** displays the icon for the CUE.
6. Select the CUE in the **Network list**.
7. Select the PC Tool function **Custom configuration**.
8. Go to section **GENIbus**, and set the unit number to the same number as that of the CUE. (Number = 1 for CUE No 1, etc. Pilot pumps are set to 10.)



Steps 7 and 8 are not necessary for the CUE in Hydro MPC-F.

9. Go to section **General**, select **Pump Family** and enter motor data. See figure Terminal groups in section IO 351A.



Motor data are to be read from the motor nameplate.

TM054467

### Custom configuration (general)

10. Select the PC Tool function **Standard configuration**.
11. Go to section **Search by** and select **Number**.
12. Enter the GCS file number according to below table in the **Configuration No.** field and click **Search Now**.

Application	Frequency	GSC file number
CUE-MPC/TOP/50 Hz	50 Hz (3000 rpm)	96890456
CUE-MPC/TOP/60 Hz	60 Hz (3600 rpm)	96890457
CUE-MPC/TOP/60 Hz - US	60 Hz (3600 rpm)	97685157

13. Select the file from the **Configuration files** field and click **Send**.
14. Switch on the power supply to the next CUE with the main switch and repeat steps 6 to 13 for each CUE.

### Related information

[4.2.1 IO 351A](#)

## 7. Danfoss frequency converters

For further documentation on Danfoss frequency converters, see the manual supplied with the frequency converter, or download it from <http://www.danfoss.com>.

## 8. CUE

Service instructions, see Grundfos Product Center.  
Service instructions, extended, see GTI.

## 9. MGE

Service instructions, see Grundfos Product Center.  
Service instructions, extended, see GTI.

## 10. Disposal

### 10.1 Precautions for disposal

#### **DANGER**

##### **Electric shock**

Death or serious personal injury



- Before you dismantle the system, make sure that the power supply is disconnected and cannot be accidentally switch on.

#### **WARNING**

##### **Crushing of feet**

Death or serious personal injury



- Before you lift, make sure that the lifting equipment is capable of lifting this load, which is listed on the nameplate and on the packaging label.

#### **WARNING**

##### **Hot surface**

Death or serious personal injury



- Before you dismantle the system, make sure that the system is cooled down.

#### **CAUTION**

##### **Overhead load**

Minor or moderate personal injury



- Use safety equipment when dismantling the system.

#### **CAUTION**

##### **Sharp element**

Minor or moderate personal injury



- Wear safety gloves.

### 10.2 Disposing of the system

This system or parts of it must be disposed of in an environmentally sound way:

1. Use the public or private waste collection service.
2. If this is not possible, contact the nearest Grundfos company or service workshop.



**Argentina**

Bombas GRUNDFOS de Argentina S.A.  
Ruta Panamericana km. 37.500 Industri  
1619 - Garin Pcia. de B.A.  
Tel.: +54-3327 414 444  
Fax: +54-3327 45 3190

**Australia**

GRUNDFOS Pumps Pty. Ltd.  
P.O. Box 2040  
Regency Park  
South Australia 5942  
Tel.: +61-8-8461-4611  
Fax: +61-8-8340-0155

**Austria**

GRUNDFOS Pumpen Vertrieb Ges.m.b.H.  
Grundfosstraße 2  
A-5082 Grödig/Salzburg  
Tel.: +43-6246-883-0  
Fax: +43-6246-883-30

**Belgium**

N.V. GRUNDFOS Bellux S.A.  
Boomsesteenweg 81-83  
B-2630 Aartselaar  
Tel.: +32-3-870 7300  
Fax: +32-3-870 7301

**Bosnia and Herzegovina**

GRUNDFOS Sarajevo  
Zmaja od Bosne 7-7A  
BiH-71000 Sarajevo  
Tel.: +387 33 592 480  
Fax: +387 33 590 465  
www.ba.grundfos.com  
E-mail: grundfos@bih.net.ba

**Brazil**

BOMBAS GRUNDFOS DO BRASIL  
Av. Humberto de Alencar Castelo Branco,  
630  
CEP 09850 - 300  
São Bernardo do Campo - SP  
Tel.: +55-11 4393 5533  
Fax: +55-11 4343 5015

**Bulgaria**

Grundfos Bulgaria EOOD  
Slatina District  
Iztochna Tangenta street no. 100  
BG - 1592 Sofia  
Tel.: +359 2 49 22 200  
Fax: +359 2 49 22 201  
E-mail: bulgaria@grundfos.bg

**Canada**

GRUNDFOS Canada inc.  
2941 Brighton Road  
Oakville, Ontario  
L6H 6C9  
Tel.: +1-905 829 9533  
Fax: +1-905 829 9512

**China**

GRUNDFOS Pumps (Shanghai) Co. Ltd.  
10F The Hub, No. 33 Suhong Road  
Minhang District  
Shanghai 201106 PRC  
Tel.: +86 21 612 252 22  
Fax: +86 21 612 253 33

**Columbia**

GRUNDFOS Colombia S.A.S.  
Km 1.5 vía Siberia-Cota Conj. Potrero  
Chico,  
Parque Empresarial Arcos de Cota Bod. 1A.  
Cota, Cundinamarca  
Tel.: +57(1)-2913444  
Fax: +57(1)-8764586

**Croatia**

GRUNDFOS CROATIA d.o.o.  
Buzinski prilaz 38, Buzin  
HR-10010 Zagreb  
Tel.: +385 1 6595 400  
Fax: +385 1 6595 499  
www.hr.grundfos.com

**Czech Republic**

GRUNDFOS Sales Czechia and Slovakia  
s.r.o.  
Čajkovského 21  
779 00 Olomouc  
Tel.: +420-585-716 111

**Denmark**

GRUNDFOS DK A/S  
Martin Bachs Vej 3  
DK-8850 Bjerringbro  
Tel.: +45-87 50 50 50  
Fax: +45-87 50 51 51  
E-mail: info\_GDK@grundfos.com  
www.grundfos.com/DK

**Estonia**

GRUNDFOS Pumps Eesti OÜ  
Peterburi tee 92G  
11415 Tallinn  
Tel.: + 372 606 1690  
Fax: + 372 606 1691

**Finland**

OY GRUNDFOS Pumput AB  
Trukkikuja 1  
FI-01360 Vantaa  
Tel.: +358-(0) 207 889 500

**France**

Pompes GRUNDFOS Distribution S.A.  
Parc d'Activités de Chesnes  
57, rue de Malacombe  
F-38290 St. Quentin Fallavier (Lyon)  
Tel.: +33-4 74 82 15 15  
Fax: +33-4 74 94 10 51

**Germany**

GRUNDFOS GMBH  
Schlüterstr. 33  
40699 Erkrath  
Tel.: +49-(0) 211 929 69-0  
Fax: +49-(0) 211 929 69-3799  
E-mail: infoservice@grundfos.de  
Service in Deutschland:  
kundendienst@grundfos.de

**Greece**

GRUNDFOS Hellas A.E.B.E.  
20th km. Athinon-Markopoulou Av.  
P.O. Box 71  
GR-19002 Peania  
Tel.: +0030-210-66 83 400  
Fax: +0030-210-66 46 273

**Hong Kong**

GRUNDFOS Pumps (Hong Kong) Ltd.  
Unit 1, Ground floor, Siu Wai industrial  
Centre  
29-33 Wing Hong Street & 68 King Lam  
Street, Cheung Sha Wan  
Kowloon  
Tel.: +852-27861706 / 27861741  
Fax: +852-27858664

**Hungary**

GRUNDFOS South East Europe Kft.  
Tópark u. 8  
H-2045 Törökbálint  
Tel.: +36-23 511 110  
Fax: +36-23 511 111

**India**

GRUNDFOS Pumps india Private Limited  
118 Old Mahabalipuram Road  
Thoraiakkam  
Chennai 600 097  
Tel.: +91-44 2496 6800

**Indonesia**

PT GRUNDFOS Pompa  
Graha intrub Lt. 2 & 3  
Jln. Cililitan Besar No.454. Makasar,  
Jakarta Timur  
ID-Jakarta 13650  
Tel.: +62 21-469-51900  
Fax: +62 21-460 6910 / 460 6901

**Ireland**

GRUNDFOS (Ireland) Ltd.  
Unit A, Merrywell Business Park  
Ballymount Road Lower  
Dublin 12  
Tel.: +353-1-4089 800  
Fax: +353-1-4089 830

**Italy**

GRUNDFOS Pompe Italia S.r.l.  
Via Gran Sasso 4  
I-20060 Truccazzano (Milano)  
Tel.: +39-02-95838112  
Fax: +39-02-95309290 / 95838461

**Japan**

GRUNDFOS Pumps K.K.  
1-2-3, Shin-Miyakoda, Kita-ku  
Hamamatsu  
431-2103 Japan  
Tel.: +81 53 428 4760  
Fax: +81 53 428 5005

**Kazakhstan**

Grundfos Kazakhstan LLP  
7' Kyz-Zhibek Str., Kok-Tobe micr.  
KZ-050020 Almaty Kazakhstan  
Tel.: +7 (727) 227-98-55/56

**Korea**

GRUNDFOS Pumps Korea Ltd.  
6th Floor, Aju Building 679-5  
Yeoksam-dong, Kangnam-ku, 135-916  
Seoul, Korea  
Tel.: +82-2-5317 600  
Fax: +82-2-5633 725

**Latvia**

SIA GRUNDFOS Pumps Latvia  
Deglava biznesa centrs  
Augusta Deglava ielā 60  
LV-1035, Rīga,  
Tel.: + 371 714 9640, 7 149 641  
Fax: + 371 914 9646

**Lithuania**

GRUNDFOS Pumps UAB  
Smolensko g. 6  
LT-03201 Vilnius  
Tel.: +370 52 395 430  
Fax: +370 52 395 431

**Malaysia**

GRUNDFOS Pumps Sdn. Bhd.  
7 Jalan Peguam U1/25  
Glenmarie industrial Park  
40150 Shah Alam, Selangor  
Tel.: +60-3-5569 2922  
Fax: +60-3-5569 2866

**Mexico**

Bombas GRUNDFOS de México  
S.A. de C.V.  
Boulevard TLC No. 15  
Parque industrial Stiva Aeropuerto  
Apodaca, N.L. 66600  
Tel.: +52-81-8144 4000  
Fax: +52-81-8144 4010

**Netherlands**

GRUNDFOS Netherlands  
Veluwezoom 35  
1326 AE Almere  
Postbus 22015  
1302 CA ALMERE  
Tel.: +31-88-478 6336  
Fax: +31-88-478 6332  
E-mail: info\_gnl@grundfos.com

**New Zealand**

GRUNDFOS Pumps NZ Ltd.  
17 Beatrice Tinsley Crescent  
North Harbour Industrial Estate  
Albany, Auckland  
Tel.: +64-9-415 3240  
Fax: +64-9-415 3250

**Norway**

GRUNDFOS Pomper A/S  
Stramsveien 344  
Postboks 235, Leirdal  
N-1011 Oslo  
Tel.: +47-22 90 47 00  
Fax: +47-22 32 21 50

**Poland**

GRUNDFOS Pompy Sp. z o.o.  
ul. Klonowa 23  
Baranowo k. Poznania  
PL-62-081 Przeźmierowo  
Tel.: (+48-61) 650 13 00  
Fax: (+48-61) 650 13 50

**Portugal**

Bombas GRUNDFOS Portugal, S.A.  
Rua Calvet de Magalhães, 241  
Apartado 1079  
P-2770-153 Paço de Arcos  
Tel.: +351-21-440 76 00  
Fax: +351-21-440 76 90

**Romania**

GRUNDFOS Pompe România SRL  
S-PARK BUSINESS CENTER, Clădirea  
A2, etaj 2  
Str. Tipografilor, Nr. 11-15, Sector 1, Cod  
013714  
Bucuresti, Romania  
Tel.: 004 021 2004 100  
E-mail: romania@grundfos.ro

**Serbia**

Grundfos Srbija d.o.o.  
Omladinskih brigada 90b  
11070 Novi Beograd  
Tel.: +381 11 2258 740  
Fax: +381 11 2281 769  
www.rs.grundfos.com

**Singapore**

GRUNDFOS (Singapore) Pte. Ltd.  
25 Jalan Tukang  
Singapore 619264  
Tel.: +65-6681 9688  
Fax: +65-6681 9689

**Slovakia**

GRUNDFOS s.r.o.  
Prievozská 4D 821 09 BRATISLAVA  
Tel.: +421 2 5020 1426  
sk.grundfos.com

**Slovenia**

GRUNDFOS LJUBLJANA, d.o.o.  
Leskoškova 9e, 1122 Ljubljana  
Tel.: +386 (0) 1 568 06 10  
Fax: +386 (0) 1 568 06 19  
E-mail: tehnika-si@grundfos.com

**South Africa**

GRUNDFOS (PTY) LTD  
16 Lascelles Drive, Meadowbrook Estate  
1609 Germiston, Johannesburg  
Tel.: (+27) 10 248 6000  
Fax: (+27) 10 248 6002  
E-mail: lgradidge@grundfos.com

**Spain**

Bombas GRUNDFOS España S.A.  
Camino de la Fuenteçilla, s/n  
E-28110 Algete (Madrid)  
Tel.: +34-91-848 8800  
Fax: +34-91-628 0465

**Sweden**

GRUNDFOS AB  
Box 333 (Lunnagårdsgatan 6)  
431 24 Mölndal  
Tel.: +46 31 332 23 000  
Fax: +46 31 331 94 60

**Switzerland**

GRUNDFOS Pumpen AG  
Bruggacherstrasse 10  
CH-8117 Fällanden/ZH  
Tel.: +41-44-806 8111  
Fax: +41-44-806 8115

**Taiwan**

GRUNDFOS Pumps (Taiwan) Ltd.  
7 Floor, 219 Min-Chuan Road  
Taichung, Taiwan, R.O.C.  
Tel.: +886-4-2305 0868  
Fax: +886-4-2305 0878

**Thailand**

GRUNDFOS (Thailand) Ltd.  
92 Chaloein Phrakiat Rama 9 Road  
Dokmai, Pravej, Bangkok 10250  
Tel.: +66-2-725 8999  
Fax: +66-2-725 8998

**Turkey**

GRUNDFOS POMPA San. ve Tic. Ltd. Sti.  
Gebze Organize Sanayi Bölgesi  
İhsan dede Caddesi  
2. yol 200. Sokak No. 204  
41490 Gebze/ Kocaeli  
Tel.: +90 - 262-679 7979  
Fax: +90 - 262-679 7905  
E-mail: satis@grundfos.com

**Ukraine**

ТОВ "ГРУНДФОС УКРАЇНА"  
Бізнес Центр Європа  
Столичне шосе, 103  
м. Київ, 03131, Україна  
Tel.: (+38 044) 237 04 00  
Fax: (+38 044) 237 04 01  
E-mail: ukraine@grundfos.com

**United Arab Emirates**

GRUNDFOS Gulf Distribution  
P.O. Box 16768  
Jebel Ali Free Zone, Dubai  
Tel.: +971 4 8815 166  
Fax: +971 4 8815 136

**United Kingdom**

GRUNDFOS Pumps Ltd.  
Grovebury Road  
Leighton Buzzard/Beds. LU7 4TL  
Tel.: +44-1525-850000  
Fax: +44-1525-850011

**U.S.A.**

Global Headquarters for WU  
856 Koomey Road  
Brookshire, Texas 77423 USA  
Phone: +1-630-236-5500

**Uzbekistan**

Grundfos Tashkent, Uzbekistan  
The Representative Office of Grundfos  
Kazakhstan in Uzbekistan  
38a, Oybek street, Tashkent  
Tel.: (+998) 71 150 3290 / 71 150 3291  
Fax: (+998) 71 150 3292

<b>98394087 04.2024</b>
ECM: 1391019