

# DDI 209

## Dosing pump

### Installation and operating instructions



## Declaration of conformity

### GB Declaration of Conformity

We, Grundfos, declare under our sole responsibility that the products DDI 209, to which this declaration relates, are in conformity with these Council directives on the approximation of the laws of the EC member states:

- Machinery Directive (2006/42/EC).  
Standards used: EN 809: 1998, EN ISO 12100-1+A1: 2009, EN ISO 12100-2+A1: 2009
- Low Voltage Directive (2006/95/EC).\*)  
Standard used: EN 60204-1+A1: 2009
- EMC Directive (2004/108/EC).  
Standards used: EN 61000-6-2: 2005, EN 61000-6-4: 2007

\*) This applies only to products with supply voltage > 50 V AC or > 75 V DC.

### BG Декларация за съответствие

Ние, фирма Grundfos, заявяваме с пълна отговорност, че продуктите DDI 209, за които се отнася настоящата декларация, отговарят на следните указания на Съвета за уеднаквяване на правните разпоредби на държавите членки на ЕС:

- Директива за машините (2006/42/EC).  
Приложен стандарт: EN 809: 1998, EN ISO 12100-1+A1: 2009 и EN ISO 12100-2+A1: 2009.
- Директива за нисковолтови системи (2006/95/EC).\*)  
Приложени стандарти: EN 60204-1+A1: 2009.
- Директива за електромагнитна съвместимост (2004/108/EC).  
Приложени стандарти: EN 61000-6-2: 2005 и EN 61000-6-4: 2007.

\*) Това е приложимо само за продукти със захранващо напрежение > 50 V AC или > 75 V DC.

### CZ Prohlášení o shodě

My firma Grundfos prohlašujeme na svou plnou odpovědnost, že výrobky DDI 209, na něž se toto prohlášení vztahuje, jsou v souladu s ustanoveními směrnice Rady pro sblížení právních předpisů členských států Evropského společenství v oblastech:

- Směrnice pro strojní zařízení (2006/42/ES).  
Použitá norma: EN 809: 1998, EN ISO 12100-1+A1: 2009 a EN ISO 12100-2+A1: 2009.
- Směrnice pro nízkonapěťové aplikace (2006/95/ES).\*)  
Použité normy: EN 60204-1+A1: 2009.
- Směrnice pro elektromagnetickou kompatibilitu (EMC) (2004/108/ES).  
Použité normy: EN 61000-6-2: 2005 a EN 61000-6-4: 2007.

\*) Používá se pouze u výrobků s napájecím napětím > 50 V AC nebo > 75 V DC.

### DK Overensstemmelseserklæring

Vi, Grundfos, erklærer under ansvar at produkterne DDI 209 som denne erklæring omhandler, er i overensstemmelse med disse af Rådets direktiver om indbyrdes tilnærmelse til EF-medlemsstaternes lovgivning:

- Maskindirektivet (2006/42/EF).  
Anvendt standard: EN 809: 1998, EN ISO 12100-1+A1: 2009 og EN ISO 12100-2+A1: 2009.
- Lavspændingsdirektivet (2006/95/EF).\*)  
Anvendte standarder: EN 60204-1+A1: 2009.
- EMC-direktivet (2004/108/EF).  
Anvendte standarder: EN 61000-6-2: 2005 og EN 61000-6-4: 2007.

\*) Dette gælder kun for produkter med forsyningssspænding > 50 V AC eller > 75 V DC.

### DE Konformitätserklärung

Wir, Grundfos, erklären in alleiniger Verantwortung, dass die Produkte DDI 209, auf die sich diese Erklärung bezieht, mit den folgenden Richtlinien des Rates zur Angleichung der Rechtsvorschriften der EU-Mitgliedsstaaten übereinstimmen:

- Maschinenrichtlinie (2006/42/EG).  
Norm, die verwendet wurde: EN 809: 1998, EN ISO 12100-1+A1: 2009 und EN ISO 12100-2+A1: 2009.
- Niederspannungsrichtlinie (2006/95/EG).\*)  
Normen, die verwendet wurden: EN 60204-1+A1: 2009.
- EMV-Richtlinie (2004/108/EG).  
Normen, die verwendet wurden: EN 61000-6-2: 2005 und EN 61000-6-4: 2007.

\*) Dies gilt nur für Produkte mit einer Versorgungsspannung > 50 V AC oder > 75 V DC.

### EE Vastavusdeklaratsioon

Meie, Grundfos, deklareerime enda ainuvastutusel, et tooted

DDI 209, mille kohta käesolev juhend käib, on vastavuses EÜ Nõukogu direktiividega EMÜ liikmesriikide seaduste ühitamise kohta, mis käsitlevad:

- Masinate ohutus (2006/42/EC).  
Kasutatud standard: EN 809: 1998, EN ISO 12100-1+A1: 2009 ja EN ISO 12100-2+A1: 2009.
- Madalpinge direktiiv (2006/95/EC).\*)  
Kasutatud standardid: EN 60204-1+A1: 2009.
- Elektromagnetiline ühilduvus (EMC direktiiv) (2004/108/EC).  
Kasutatud standardid: EN 61000-6-2: 2005 ja EN 61000-6-4: 2007.

\*) See kehtib ainult toodetele toitepingega > 50 V AC või > 75 V DC.

## GR Δήλωση Συμμόρφωσης

Εμείς, η Grundfos, δηλώνουμε με αποκλειστικά δική μας ευθύνη ότι τα προϊόντα DDI 209 στα οποία αναφέρεται η παρούσα δήλωση, συμμορφώνονται με τις εξής Οδηγίες του Συμβουλίου περί προσέγγισης των νομοθεσιών των κρατών μελών της ΕΕ:

- Οδηγία για μηχανήματα (2006/42/EC).  
Πρότυπο που χρησιμοποιήθηκε: EN 809: 1998, EN ISO 12100-1+A1: 2009 και EN ISO 12100-2+A1: 2009.
- Οδηγία χαμηλής τάσης (2006/95/EC)\*.  
Πρότυπα που χρησιμοποιήθηκαν: EN 60204-1+A1: 2009.
- Οδηγία Ηλεκτρομαγνητικής Συμβατότητας (EMC) (2004/108/EC).  
Πρότυπα που χρησιμοποιήθηκαν: EN 61000-6-2: 2005 και EN 61000-6-4: 2007.

\*) Ισχύει μόνο για προϊόντα με τάση τροφοδοσίας > 50 V AC ή > 75 V DC.

## FR Déclaration de Conformité

Nous, Grundfos, déclarons sous notre seule responsabilité, que les produits DDI 209, auxquels se réfère cette déclaration, sont conformes aux Directives du Conseil concernant le rapprochement des législations des Etats membres CE relatives aux normes énoncées ci-dessous :

- Directive Machines (2006/42/CE).  
Norme utilisée : EN 809 : 1998, EN ISO 12100-1+A1 : 2009 et EN ISO 12100-2+A1 : 2009.
- Directive Basse Tension (2006/95/CE).\*)  
Normes utilisées : EN 60204-1+A1 : 2009.
- Directive Compatibilité Electromagnétique CEM (2004/108/CE).  
Normes utilisées : EN 61000-6-2 : 2005 et EN 61000-6-4 : 2007.

\*) Cela s'applique uniquement aux produits dont la tension d'alimentation est > à 50 V AC ou > à 75 V DC.

## IT Dichiarazione di Conformità

Grundfos dichiara sotto la sua esclusiva responsabilità che i prodotti DDI 209, ai quali si riferisce questa dichiarazione, sono conformi alle seguenti direttive del Consiglio riguardanti il riavvicinamento delle legislazioni degli Stati membri CE:

- Direttiva Macchine (2006/42/CE).  
Norma applicata: EN 809: 1998, EN ISO 12100-1+A1: 2009 e EN ISO 12100-2+A1: 2009.
- Direttiva Bassa Tensione (2006/95/CE).\*)  
Norme applicate: EN 60204-1+A1: 2009.
- Direttiva EMC (2004/108/CE).  
Norme applicate: EN 61000-6-2: 2005 e EN 61000-6-4: 2007.

\*) Questo è applicabile solo a prodotti con tensione di alimentazione > 50 VAC o > 75 VDC.

## ES Declaración de Conformidad

Meie, Grundfos, deklareerime enda ainuvastutusel, et tooted

DDI 209, mille kohta käesolev juhend käib, on vastavuses EÜ Nõukogu direktiividega EMÜ liikmesriikide seaduste ühitamise kohta, mis käsitlevad:

- Masinate ohutus (2006/42/EC).  
Kasutatud standardid: EN 809: 1998, EN ISO 12100-1+A1: 2009 ja EN ISO 12100-2+A1: 2009.
- Madalpinge direktiiv (2006/95/EC).\*)  
Kasutatud standardid: EN 60204-1+A1: 2009.
- Elektromagnetiline ühilduvus (EMC direktiiv) (2004/108/EC).  
Kasutatud standardid: EN 61000-6-2: 2005 ja EN 61000-6-4: 2007.

\*) See kehtib ainult toodetele toitepingega > 50 V AC või > 75 V DC.

## HR Izjava o usklađenosti

Mi, Grundfos, izjavljujemo pod vlastitom odgovornošću da je proizvod DDI 209, na koji se ova izjava odnosi, u skladu s direktivama ovog Vijeća o usklađivanju zakona država članica EU:

- Direktiva za strojeve (2006/42/EZ).  
Korištena norma: EN 809: 1998, EN ISO 12100-1+A1: 2009 i EN ISO 12100-2+A1: 2009.
- Direktiva za niski napon (2006/95/EZ).\*)  
Korištene norme: EN 60204-1+A1: 2009.
- Direktiva za elektromagnetsku kompatibilnost (2004/108/EZ).  
Korištene norme: EN 61000-6-2: 2005 i EN 61000-6-4: 2007.

\*) Ovo se odnosi samo na proizvode s opskrbrnim naponom > 50 V AC ili > 75 V DC.

## HU Megfelelőségi nyilatkozat

Mi, a Grundfos, egyedüli felelősséggel kijelentjük, hogy a DDI 209 termékek, amelyekre jelen nyilatkozik vonatkozik, megfelelnek az Európai Unió tagállamainak jogi irányelveit összehangoló tanács alábbi előírásainak:

- Gépek (2006/42/EK).  
Alkalmazott szabvány: EN 809: 1998 EN 809: 1998, EN ISO 12100-1+A1: 2009 és EN ISO 12100-2+A1: 2009.
- Kisfeszültségű Direktíva (2006/95/EK).\*)  
Alkalmazott szabványok: EN 60204-1+A1: 2009.
- EMC Direktíva (2004/108/EK).  
Alkalmazott szabványok: EN 61000-6-2: 2005 és EN 61000-6-4: 2007.

\*) Ez csak a > 50 V AC vagy > 75 V DC tápfeszültségű termékekre vonatkozik.

## NL Overeenkomstigheidsverklaring

Wij, Grundfos, verklaren geheel onder eigen verantwoordelijkheid dat de producten DDI 209 waarop deze verklaring betrekking heeft, in overeenstemming zijn met de Richtlijnen van de Raad in zake de onderlinge aanpassing van de wetgeving van de EG Lidstaten betreffende:

- Machine Richtlijn (2006/42/EC).  
Gebruikte norm: EN 809: 1998, EN ISO 12100-1+A1: 2009 en EN ISO 12100-2+A1: 2009.
- Laagspannings Richtlijn (2006/95/EC).\*)  
Gebruikte normen: EN 60204-1+A1: 2009.
- EMC Richtlijn (2004/108/EC).  
Gebruikte normen: EN 61000-6-2: 2005 en EN 61000-6-4: 2007.

\*) Dit is alleen van toepassing voor producten met voedingsspanning 50 V AC of > 75 V DC.

## PT Declaração de Conformidade

A Grundfos declara sob sua única responsabilidade que os produtos DDI 209, aos quais diz respeito esta declaração, estão em conformidade com as seguintes Directivas do Conselho sobre a aproximação das legislações dos Estados Membros da CE:

- Directiva Máquinas (2006/42/CE).  
Norma utilizada: EN 809: 1998, EN ISO 12100-1+A1: 2009 e EN ISO 12100-2+A1: 2009.
- Directiva Baixa Tensão (2006/95/CE).\*)  
Normas utilizadas: EN 60204-1+A1: 2009.
- Directiva EMC (compatibilidade electromagnética) (2004/108/CE).  
Normas utilizadas: EN 61000-6-2: 2005 e EN 61000-6-4: 2007.

\*) Isto aplica-se apenas a produtos com tensão de alimentação > 50 V AC ou > 75 V DC.

## RO Declarație de Conformitate

Noi, Grundfos, declarăm pe propria răspundere că produsele

DDI 209, la care se referă această declarație, sunt în conformitate cu acele Directive de Consiliu asupra armonizării legilor Statelor Membre CE:

- Directiva Utilaje (2006/42/CE).  
Standard utilizat: EN 809: 1998, EN ISO 12100-1+A1: 2009 și EN ISO 12100-2+A1: 2009.
- Directiva Tensiune Joasă (2006/95/CE).\*)  
Standarde utilizate: EN 60204-1+A1: 2009.
- Directiva EMC (2004/108/CE).  
Standarde utilizate: EN 61000-6-2: 2005 și EN 61000-6-4: 2007.

\*) Se aplică numai produselor cu tensiunea de alimentare > 50 V AC ori > 75 V DC.

## PL Deklaracja zgodności

My, Grundfos, oświadczamy z pełną odpowiedzialnością, że nasze wyroby DDI 209, których deklaracja niniejsza dotyczy, są zgodne z następującymi wytycznymi Rady d/s ujednoczenia przepisów prawnych krajów członkowskich WE:

- Dyrektywa Maszynowa (2006/42/WE).  
Zastosowana norma: EN 809: 1998, EN ISO 12100-1+A1: 2009 oraz EN ISO 12100-2+A1: 2009.
- Dyrektywa Niskonapięciowa (LVD) (2006/95/WE).\*)  
Zastosowane normy: EN 60204-1+A1: 2009.
- Dyrektywa EMC (2004/108/WE).  
Zastosowane normy: EN 61000-6-2: 2005 oraz EN 61000-6-4: 2007.

\*) Dotyczy to tylko produktów o napięciu zasilania > 50 AC lub > 75 V DC.

## RU Декларация о соответствии

Мы, компания Grundfos, со всей ответственностью заявляем, что изделия DDI 209, к которым относится настоящая декларация, соответствуют следующим Директивам Совета Евросоюза об унификации законодательных предписаний стран-членов ЕС:

- Механические устройства (2006/42/EC).  
Применявшийся стандарт: EN 809: 1998, EN ISO 12100-1+A1: 2009 и EN ISO 12100-2+A1: 2009.
- Низковольтное оборудование (2006/95/EC).\*)  
Применявшиеся стандарты: EN 60204-1+A1: 2009.
- Электромагнитная совместимость (2004/108/EC).  
Применявшиеся стандарты: EN 61000-6-2: 2005 и EN 61000-6-4: 2007.

\*) Относится только к продуктам с сетевым напряжением > 50 В переменного тока или > 75 В постоянного тока.

## SK Prehlásenie o konformite

My firma Grundfos prehlasujeme na svoju plnú zodpovednosť, že výrobky DDI 209, na ktoré sa toto prehlásenie vzťahuje, sú v súlade s ustanovením smernice Rady pre zblíženie právnych predpisov členských štátov Európskeho spoločenstva v oblastiach:

- Smernica pre strojové zariadenie (2006/42/EC).  
Použitá norma: EN 809: 1998, EN ISO 12100-1+A1: 2009 a EN ISO 12100-2+A1: 2009.
- Smernica pre nízkonapäťové aplikácie (2006/95/EC).\*)  
Použitá norma: EN 60204-1+A1: 2009.
- Smernica pre elektromagnetickú kompatibilitu (2004/108/EC).  
Použitá norma: EN 61000-6-2: 2005 a EN 61000-6-4: 2007.

\*) To sa vzťahuje len na výrobky s napájacím napätím > 50 V AC alebo > 75 V DC.

## SI Izjava o skladnosti

V Grundfosu s polno odgovornostjo izjavljamo, da so naši izdelki DDI 209, na katere se ta izjava nanaša, v skladu z naslednjimi direktivami Sveta o približevanju zakonodaje za izenačevanje pravnih predpisov držav članic ES:

- Direktiva o strojih (2006/42/ES).  
Uporabljena norma: EN 809: 1998, EN ISO 12100-1+A1: 2009 in EN ISO 12100-2+A1: 2009.
- Direktiva o nizki napetosti (2006/95/ES).\*)  
Uporabljeni normi: EN 60204-1+A1: 2009.
- Direktiva o elektromagnetni združljivosti (EMC) (2004/108/ES).  
Uporabljeni normi: EN 61000-6-2: 2005 in EN 61000-6-4: 2007.

\*) To velja samo za proizvode z napajalno napetostjo > 50 V AC ali > 75 V DC.

## SE Försäkran om överensstämmelse

Vi, Grundfos, försäkrar under ansvar att produkterna DDI 209, som omfattas av denna försäkran, är i överensstämmelse med rådets direktiv om inbördes närmande till EU-medlemsstaternas lagstiftning, avseende:

- Maskindirektivet (2006/42/EG).  
Tillämpad standard: EN 809: 1998, EN ISO 12100-1+A1: 2009 och EN ISO 12100-2+A1: 2009.
- Lågspänningsdirektivet (2006/95/EG).\*)  
Tillämpade standarder: EN 60204-1+A1: 2009.
- EMC-direktivet (2004/108/EG).  
Tillämpade standarder: EN 61000-6-2: 2005 och EN 61000-6-4: 2007.

\*) Detta gäller bara för produkter med försörjningsspänning > 50 V AC eller > 75 V DC.

## CN 产品合格声明书

我们格兰富在我们的全权责任下声明，产品 DDI 209，即该合格证所指之产品，符合欧共体使其成员国法律趋于一致的以下欧共理事会指令：

- 机械设备指令 (2006/42/EC).  
所用标准：EN 809: 1998, EN ISO 12100-1+A1: 2009 和 EN ISO 12100-2+A1: 2009.
- 低电压指令 (2006/95/EC)。\*)  
所用标准：EN 60204-1+A1: 2009.
- 电磁兼容性指令 (2004/108/EC).  
所用标准：EN 61000-6-2: 2005 和 EN 61000-6-4: 2007.

\*) 仅适用于工作电压 > 50 VAC 或 > 75 VDC 的产品。

## FI Vaatimustenmukaisuusvakuutus

Me, Grundfos, vakuutamme omalla vastuullamme, että tuotteet DDI 209, joita tämä vakuutus koskee, ovat EY:n jäsenvaltioiden lainsäädännön yhdenmukaistamiseen tähtäävien Euroopan neuvoston direktiivien vaatimusten mukaisia seuraavasti:

- Konedirektiivi (2006/42/EY).  
Sovellettu standardi: EN 809: 1998, EN ISO 12100-1+A1: 2009 ja EN ISO 12100-2+A1: 2009.
- Pienjännitedirektiivi (2006/95/EY).\*)  
Sovellettavat standardit: EN 60204-1+A1: 2009.
- EMC-direktiivi (2004/108/EY).  
Sovellettavat standardit: EN 61000-6-2: 2005 ja EN 61000-6-4: 2007.

\*) Koskee vain tuotteita, joiden käyttöjännite on > 50 V AC tai > 75 V DC.

## TR Uygunluk Bildirgesi

Grundfos olarak bu beyannameye konu olan DDI 209 ürünlerinin, AB Üyesi Ülkelerin kanunlarını birbirine yaklaştırma üzerine KONSEY Direktifleriyle uyumlu olduğunun yalnızca bizim sorumluluğumuz altında olduğunu beyan ederiz:

- Makineler Yönetmeliği (2006/42/EC).  
Kullanılan standart: EN 809: 1998, EN ISO 12100-1+A1: 2009 ve EN ISO 12100-2+A1: 2009.
- Düşük Voltaj Yönetmeliği (2006/95/EC).\*)  
Kullanılan standartlar: EN 60204-1+A1: 2009.
- EMC Direktifi (2004/108/EC).  
Kullanılan standartlar: EN 61000-6-2: 2005 ve EN 61000-6-4: 2007.

\*) Bu sadece > 50 V AC ve > 75 V DC ürünler için geçerlidir.

Pfintzal, 1st November 2010

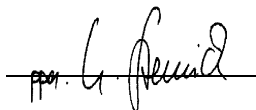

Ulrich Stemick  
Technical Director  
Grundfos Water Treatment GmbH  
Reetzstr. 85, D-76327 Pfintzal, Germany

Person authorised to compile technical file and empowered to sign the EC declaration of conformity.

# English (GB) Installation and operating instructions

## Original installation and operating instructions.

### CONTENTS

|   | Page      |  | Page      |
|---|-----------|--|-----------|
| <b>1. General information</b>   | <b>6</b>  | <b>8. Operation</b>  | <b>35</b> |
| 1.1 Introduction  | 6         | 8.1 Control and display elements                           | 35        |
| 1.2 Service documentation   | 6         | 8.2 Switching on/off                                       | 35        |
| 1.3 Information about the product   | 7         | 8.3 Checking the dosing flow with Plus <sup>3</sup> system | 35        |
| 1.4 Applications  | 12        | 8.4 Deaeration   | 36        |
| 1.5 Warranty  | 12        | 8.5 Changing the tank with Plus <sup>3</sup> system        | 36        |
| <b>2. Safety</b>  | <b>12</b> | <b>9. How to use the control unit</b>                      | <b>36</b> |
| 2.1 Identification of safety instructions in this manual                  | 12        | 9.1 Menu levels  | 36        |
| 2.2 Marking at the pump   | 12        | 9.2 General functions of the control unit                  | 36        |
| 2.3 Qualification and training of personnel                               | 13        | 9.3 Signal outputs   | 38        |
| 2.4 Risks when safety instructions are not observed                       | 13        | 9.4 First function level                                   | 39        |
| 2.5 Safety-conscious working  | 13        | 9.5 Second function level                                  | 41        |
| 2.6 Safety instructions for the operator/user                             | 13        | 9.6 Calibration  | 44        |
| 2.7 Safety instructions for maintenance, inspection and installation work | 13        | 9.7 Service level  | 47        |
| 2.8 Unauthorised modification and manufacture of spare parts              | 13        | 9.8 Resetting to default settings                          | 50        |
| 2.9 Improper operating methods  | 13        | 9.9 Current signal control 0-20 mA / 4-20 mA               | 50        |
| 2.10 Safety of the system in the event of a failure in the dosing system  | 13        | 9.10 Flow Monitor  | 57        |
| <b>3. Transport and intermediate storage</b>                              | <b>14</b> | 9.11 Batch menu / batch mode                               | 62        |
| 3.1 Transport   | 14        | 9.12 Timer menu / timer mode                               | 63        |
| 3.2 Delivery  | 14        | 9.13 Creating a master/slave application                   | 65        |
| 3.3 Unpacking   | 14        | 9.14 Hotkeys / info keys                                   | 66        |
| 3.4 Intermediate storage  | 14        | <b>10. Maintenance</b>                                     | <b>67</b> |
| 3.5 Return  | 14        | 10.1 General notes   | 67        |
| <b>4. Technical data</b>  | <b>14</b> | 10.2 Maintenance intervals                                 | 67        |
| 4.1 Identification  | 14        | 10.3 Cleaning suction and discharge valves                 | 67        |
| 4.2 Type key  | 15        | 10.4 Replacing the diaphragm                               | 68        |
| 4.3 General description   | 16        | <b>11. Fault finding chart</b>                             | <b>70</b> |
| 4.4 Dimensional sketches  | 20        | <b>12. Disposal</b>  | <b>71</b> |
| 4.5 Weight  | 22        |  |           |
| 4.6 Materials   | 22        |  |           |
| 4.7 Control unit  | 22        |  |           |
| <b>5. Installation</b>  | <b>23</b> |  |           |
| 5.1 General information on installation                                   | 23        |  |           |
| 5.2 Installation location   | 23        |  |           |
| 5.3 Mounting  | 23        |  |           |
| 5.4 Installation examples   | 24        |  |           |
| 5.5 Installation tips   | 25        |  |           |
| 5.6 Tube / pipe lines   | 26        |  |           |
| <b>6. Electrical connections</b>  | <b>27</b> |  |           |
| 6.1 Connecting the signal lines for DDI 209                               | 28        |  |           |
| 6.2 Connecting the power supply cable                                     | 31        |  |           |
| <b>7. Start-up / shutdown</b>   | <b>31</b> |  |           |
| 7.1 Initial start-up / subsequent start-up                                | 31        |  |           |
| 7.2 Operating the pump  | 34        |  |           |
| 7.3 Shutdown  | 34        |  |           |

#### Warning

*These complete installation and operating instructions are also available on [www.Grundfosalldos.com](http://www.Grundfosalldos.com).*



*Prior to installation, read these installation and operating instructions. Installation and operation must comply with local regulations and accepted codes of good practice.*

## 1. General information

### 1.1 Introduction

These installation and operating instructions contain all the information required for starting up and handling the DDI 209 diaphragm dosing pump.

If you require further information or if any problems arise, which are not described in detail in this manual, please contact the nearest Grundfos company.

### 1.2 Service documentation

If you have any questions, please contact the nearest Grundfos company or service workshop.

## 1.3 Information about the product

### 1.3.1 Pump types

The DDI 209 dosing pump is available for a variety of performance ranges in various sizes:

| Pump types |
|------------|
| DDI 0.4-10 |
| DDI 2.2-16 |
| DDI 2.5-10 |
| DDI 5.5-10 |
| DDI 13.8-4 |
| DDI 20-3   |

The following is indicated on the pump nameplate (see section 4.1 *Identification*):

- The pump type which specifies the stroke volume, connection size and performance data (see below).
- The pump serial number which is used to identify the pump.
- The most important characteristics of the pump configuration, e.g. dosing head and valve materials. They are described in section 4.2 *Type key*.
- Maximum flow rate and maximum counter-pressure.
- Supply voltage or mains voltage and mains frequency.

**Note**

*The pump for viscous liquids is called HV variant in the following.*

### 1.3.2 Connection size

| Pump type  | Connection size | HV variant |
|------------|-----------------|------------|
| DDI 0.4-10 | DN 4            | DN 4       |
| DDI 2.2-16 | DN 4            | DN 8       |
| DDI 2.5-10 | DN 4            | DN 8       |
| DDI 5.5-10 | DN 4            | DN 8       |
| DDI 13.8-4 | DN 8/10         | DN 8       |
| DDI 20-3   | DN 8/10         | DN 8       |

### 1.3.3 Pump performance

#### Performance data at maximum pump counter-pressure

| Pump type  | Normal operation |                               |         |                  | Slow-mode operation |                               |         |                  |
|------------|------------------|-------------------------------|---------|------------------|---------------------|-------------------------------|---------|------------------|
|            | Q**              |                               | p max.* | Max. stroke rate | Q**                 |                               | p max.* | Max. stroke rate |
|            | Standard         | With Plus <sup>3</sup> system |         |                  | Standard            | With Plus <sup>3</sup> system |         |                  |
|            | [l/h]            | [l/h]                         | [bar]   | [n/min]          | [l/h]               | [l/h]                         | [bar]   | [n/min]          |
| DDI 0.4-10 | 0.4***           | 0.4***                        | 10      | 180              | 0.26***             | 0.26***                       | 10      | 120              |
| DDI 2.2-16 | 2.2              | 1.9                           | 16      | 180              | 1.5                 | 1.2                           | 16      | 120              |
| DDI 2.5-10 | 2.5              | 2.2                           | 10      | 180              | 1.7                 | 1.4                           | 10      | 120              |
| DDI 5.5-10 | 5.5              | 4.9                           | 10      | 180              | 3.7                 | 3.2                           | 10      | 120              |
| DDI 13.8-4 | 13.8             | —                             | 4       | 180              | 9.2                 | —                             | 4       | 120              |
| DDI 20-3   | 20               | —                             | 3       | 180              | 13.3                | —                             | 3       | 120              |

\* Observe the maximum permissible temperatures and that the friction loss increases with the viscosity of the dosing medium.

\*\* The maximum dosing flow of HV-variant pumps is up to 10 % lower.

\*\*\* At counter-pressures lower than 10 bar, the maximum dosing flow of the DDI 0.4-10 gradually increases to up to 1 l/h.

Note

***The pump can be operated in the range between 1 % and 100 % of the maximum dosing capacity.***

Note

***The maximum display indication is higher than the nominal capacity of the pump because it refers to the default setting.***



### 1.3.4 Accuracy

- Applies to:
  - water as dosing medium
  - fully deaerated dosing head
  - standard pump version.
- Dosing flow fluctuation and linearity deviation:  $\pm 1.5\%$  of the full-scale value.
- Construction tolerance: according to VDMA 24284.

### 1.3.5 Inlet pressure and counter-pressure / suction lift during operation

#### Maximum inlet pressure

| Pump type                  | Operating conditions / version* |                     |   |
|----------------------------|---------------------------------|---------------------|---|
|                            | Normal operation                | Slow-mode operation | With Plus <sup>3</sup> system                   |
|                            | [bar]                           | [bar]               | [bar]   |
| DDI 0.4-10 -<br>DDI 5.5-10 | 2                               | 2                   | No flooded suction, no positive inlet pressure! |
| DDI 13.8-4                 | 2                               | 2                   | —   |
| DDI 20-3                   | 1.5                             | 1.5                 | —   |

\* For pumps with pressure sensor (Flow Monitor pump option), the inlet pressure on the suction side must not exceed 1 bar.

#### Minimum counter-pressure at the pump discharge valve

| Pump type                | Operating conditions / version* |
|--------------------------|---------------------------------|
|                          | All*                            |
|                          | [bar]                           |
| DDI 0.4-10 -<br>DDI 20-3 | 1                               |

\* For pumps with pressure sensor (Flow Monitor pump option), the minimum system pressure is 2 bar and the minimum pressure difference between the suction and discharge sides is 2 bar. If the volume flow is not constant (as, for example, in the case of contact or analog control), even small volume flows should not fall below the minimum pressure or the minimum pressure difference.

#### Maximum suction lift\* (start-up) for media with a viscosity similar to water

| Pump type  | Operating conditions / version |  |
|------------|--------------------------------|--|
|            | Continuous operation           | Continuous operation with Plus <sup>3</sup> system |
|            | [m]                            | [m]  |
| DDI 0.4-10 | Flooded suction                | **   |
| DDI 2.2-16 | 1.5                            | **   |
| DDI 2.5-10 | 1.5                            | **   |
| DDI 5.5-10 | 2.0                            | **   |
| DDI 13.8-4 | 2.8                            | —  |
| DDI 20-3   | 2.8                            | —  |

\* Deaeration valve open.

\*\* Pumps with Plus<sup>3</sup> system are delivered with a special start-up device.

**Maximum suction lift\* (continuous operation) for non-degassing media with a viscosity similar to water**

| Pump type  | Operating conditions / version |                     |  |   |
|------------|--------------------------------|---------------------|--|---|
|            | Normal operation               | Slow-mode operation | Normal operation with Plus <sup>3</sup> system | Slow-mode operation with Plus <sup>3</sup> system |
|            | [m]                            | [m]                 | [m]  | [m]   |
| DDI 0.4-10 | Flooded suction                | Flooded suction     | 1.5  | 1.5   |
| DDI 2.2-16 | 4                              | 6                   | 1.5  | 1.5   |
| DDI 2.5-10 | 4                              | 6                   | 1.5  | 1.5   |
| DDI 5.5-10 | 4                              | 6                   | 1.5  | 1.5   |
| DDI 13.8-4 | 3                              | 3                   | —  | —   |
| DDI 20-3   | 3                              | 3                   | —  | —   |

\* Dosing head and valves moistened.

**1.3.6 Sound pressure level**

45 dB(A), testing according to DIN 45635-01-KL3.

Note

***At dosing capacities up to 10 % of the maximum dosing capacity of the pump, resonance noise may temporarily occur at the stepper motor.***

**1.3.7 Enclosure class**

Caution

***The enclosure class is only met if the sockets are protected! The data regarding the enclosure class applies to pumps with correctly inserted plugs or screwed-on caps.***

- Pump with mains plug: IP65.
- Pump without mains plug: IP65 can only be ensured if the power supply cable is connected with IP65 protection.

**1.3.8 Required energy****Power supply for AC voltage**

- Rated voltage range: 110-240 V.  
Deviation from the rated value:  $\pm 10\%$ .
- Mains frequency: 50/60 Hz.
- Maximum input power: 20 W including all sensors (reduced input power according to pump type and connected sensors).

**24 V DC power supply**

- Supply voltage: 24 V.  
Deviation from the rated value:  $\pm 15\%$ .
- Quality of the DC voltage: smoothed, ripple below 3.6 V.
- Maximum input power: 20 W including all sensors (reduced input power according to pump type and connected sensors).

Note

***The power supply must be electrically isolated from the signal inputs and outputs.***

**1.3.9 Ambient and operating conditions**

- Permissible ambient temperature: 0 °C to +40 °C.
- Permissible storage temperature: -10 °C to +50 °C.
- Permissible air humidity: max. relative humidity: 92 % (non-condensing).

**Warning**

***The DDI 209 is NOT approved for operation in potentially explosive areas!***

***The installation site must be under cover!***

***Ensure that the enclosure class of motor and pump is not affected by the atmospheric conditions.***

Caution

***Pumps with electronics are only suitable for indoor use!  
Do not install outdoors!***

### 1.3.10 Dosing medium

**Caution**

*In the event of questions regarding the material resistance and suitability of the pump for specific dosing media, please contact Grundfos.*

The dosing medium must have the following basic characteristics:

- liquid
- non-abrasive
- non-inflammable.

For degassing dosing media, note the following:

- The DDI 209 without Plus<sup>3</sup> system can be used in flooded suction for moderately degassing media such as chlorine bleaching agents. See section 5. *Installation*.
- The DDI 209 with Plus<sup>3</sup> system can be used for moderately degassing media such as chlorine bleaching agents. Using the DDI 5.5-10 with Plus<sup>3</sup> system at a maximum system pressure of 3 bar, H<sub>2</sub>O<sub>2</sub> up to a maximum of 31 % can be dosed. No flooded suction!

#### Maximum permissible viscosity at operating temperature\*

| Pump type                  | Maximum viscosity* |                     |  |   |
|----------------------------|--------------------|---------------------|--|---|
|                            | Normal operation   | Slow-mode operation | Normal operation with Plus <sup>3</sup> system | Slow-mode operation with Plus <sup>3</sup> system |
|                            | [mPa s]            | [mPa s]             | [mPa s]  | [mPa s]   |
| DDI 0.4-10 -<br>DDI 2.5-10 | 200                | 200                 | 200  | 200   |
| DDI 5.5-10                 | 100                | 200                 | 100  | 200   |
| DDI 13.8-4 -<br>DDI 20-3   | 100                | 200                 | —  | —   |
| <b>Pump type</b>           | <b>HV variant</b>  |                     |  |   |
| DDI 0.4-10                 | 500                | 1000                | 500  | 500   |
| DDI 2.2-16 -<br>DDI 2.5-10 | 200                | 1000                | —  | —   |
| DDI 5.5-10 -<br>DDI 20-3   | 200                | 500                 | —  | —   |

\* The stated values are approximate values and apply to Newtonian liquids.  
Note that the viscosity increases with decreasing temperature!

## Permissible media temperature

| Dosing head material         | Min. media temperature | Max. media temperature |            |
|------------------------------|------------------------|------------------------|------------|
|                              |                        | p < 10 bar             | p < 16 bar |
|                              | [°C]                   | [°C]                   | [°C]       |
| PVC                          | 0                      | 40                     | 20         |
| Stainless steel, DIN 1.4571* | -10                    | 70                     | 70         |
| PP                           | 0                      | 40                     | 20         |
| PVDF**                       | -10                    | 60*                    | 20         |

\* A temperature of 120 °C at a counter-pressure of max. 2 bar is permitted for a short period (15 minutes).

\*\* At 70 °C, the maximum counter-pressure is 3 bar.



### Warning

**Observe the manufacturer's safety instructions when handling chemicals!**

### Caution

**The dosing medium must be in liquid form!**

**Observe the freezing and boiling points of the dosing medium!**

**The resistance of the parts that come into contact with the media depends on the media, media temperature and operating pressure. Ensure that parts in contact with the media are chemically resistant to the dosing medium under operating conditions!**

### Caution

**Make sure that the pump is suitable for the actual dosing medium!**

## 1.4 Applications

### 1.4.1 Appropriate, acceptable and correct usage

The DDI 209 pump is suitable for liquid, non-abrasive and non-inflammable media strictly in accordance with the instructions in this manual.

### Warning

**Other applications or the operation of pumps in ambient and operating conditions, which are not approved, are considered improper and are not permitted. Grundfos accepts no liability for any damage resulting from incorrect use.**



## 1.5 Warranty

Warranty in accordance with our general terms of sale and delivery is only valid

- if the pump is used in accordance with the information within this manual.
- if the pump is not dismantled or incorrectly handled.
- if repairs are carried out by authorised and qualified personnel.
- if original spare parts are used for repairs.

## 2. Safety

This manual contains general instructions that must be observed during installation, operation and maintenance of the pump. This manual must therefore be read by the installation engineer and the relevant qualified personnel/operators prior to installation and start-up, and must be available at the installation location of the pump at all times.

It is not only the general safety instructions given in this "Safety" section that must be observed, but also all the specific safety instructions given in other sections.

### 2.1 Identification of safety instructions in this manual

If the safety instructions or other advice in this manual are not observed, it may result in personal injury or malfunction and damage to the pump. The safety instructions and other advice are identified by the following symbols:



### Warning

**If these safety instructions are not observed, it may result in personal injury!**

### Caution

**If these safety instructions are not observed, it may result in malfunction or damage to the equipment!**

### Note

**Notes or instructions that make the job easier and ensure safe operation.**

Information provided directly on the pump, e.g. labelling of fluid connections, must be observed and must be maintained in a readable condition at all times.

### 2.2 Marking at the pump

The pumps with Plus<sup>3</sup> system are provided with the following danger notice:

#### **Beware of caustic liquids!**

**Risk of causticisation by the dosing medium!**



**If the pump is filled, keep the cover closed and do not touch inside the priming chamber!**

**Before dismantling and transporting the pump, empty the priming chamber completely and clean it, if necessary!**

## 2.3 Qualification and training of personnel

The personnel responsible for the operation, maintenance, inspection and installation must be appropriately qualified for these tasks. Areas of responsibility, levels of authority and the supervision of the personnel must be precisely defined by the operator.

If the personnel do not have the necessary knowledge, the necessary training and instruction must be given. If necessary, training can be performed by the manufacturer/supplier at the request of the operator of the pump. It is the responsibility of the operator to make sure that the contents of this manual are understood by the personnel.

## 2.4 Risks when safety instructions are not observed

Non-observance of the safety instructions may have dangerous consequences for the personnel, the environment and the pump. If the safety instructions are not observed, all rights to claims for damages may be lost.

Non-observance of the safety instructions may lead to the following hazards:

- failure of important functions of the pump/system
- failure of specified methods for maintenance
- harm to humans from exposure to electrical, mechanical and chemical influences
- damage to the environment from leakage of harmful substances.

## 2.5 Safety-conscious working

The safety instructions in this manual, applicable national health and safety regulations and any operator internal working, operating and safety regulations must be observed.

## 2.6 Safety instructions for the operator/user

Hazardous hot or cold parts on the pump must be protected to prevent accidental contact.

Leakages of dangerous substances (e.g. hot, toxic) must be disposed of in a way that is not harmful to the personnel or the environment. Legal regulations must be observed.

Damage caused by electrical energy must be prevented (for more details, see for example the regulations of the VDE and the local electricity supply company).

## 2.7 Safety instructions for maintenance, inspection and installation work

The operator must ensure that all maintenance, inspection and installation work is carried out by authorised and qualified personnel, who have been adequately trained by reading this manual.

All work on the pump should only be carried out when the pump is stopped. The procedure described in this manual for stopping the pump must be observed.

Pumps or pump units which are used for media that are harmful to health must be decontaminated.

All safety and protective equipment must be immediately restarted or put into operation once work is complete.

Observe the points described in the initial start-up section prior to subsequent start-up.



### Warning

**Electrical connections must only be carried out by qualified personnel!**

**The pump housing must only be opened by personnel authorised by Grundfos!**

## 2.8 Unauthorised modification and manufacture of spare parts

Modification or changes to the pump are only permitted following agreement with the manufacturer. Original spare parts and accessories authorised by the manufacturer are safe to use. Using other parts can result in liability for any resulting consequences.

## 2.9 Improper operating methods

The operational safety of the supplied pump is only ensured if it is used in accordance with section 1. *General information*. The specified limit values must under no circumstances be exceeded.

## 2.10 Safety of the system in the event of a failure in the dosing system

DDI 209 dosing pumps are designed according to the latest technologies and are carefully manufactured and tested. However, a failure may occur in the dosing system. Systems in which dosing pumps are installed must be designed in such a way that the safety of the entire system is still ensured following a failure of the dosing pump. Provide the relevant monitoring and control functions for this.

### 3. Transport and intermediate storage

#### 3.1 Transport

**Caution** Do not throw or drop the pump.

#### 3.2 Delivery

The DDI 209 dosing pump is delivered in a cardboard box. Place the pump in the packaging during transport and intermediate storage.

#### 3.3 Unpacking

Retain the packaging for future storage or return, or dispose of the packaging in accordance with local regulations.

#### 3.4 Intermediate storage

- Permissible storage temperature:  $-10\text{ }^{\circ}\text{C}$  to  $+50\text{ }^{\circ}\text{C}$ .
- Permissible air humidity: max. relative humidity: 92 % (non-condensing).

#### 3.5 Return

Return the pump in its original packaging or equivalent.

The pump must be thoroughly cleaned before it is returned or stored. It is essential that there are no traces of toxic or hazardous media remaining on the pump.

**Caution** *Grundfos accepts no liability for damage caused by incorrect transportation or missing or unsuitable packaging of the pump!*

Before returning the pump to Grundfos Water Treatment for service, the **safety declaration** at the end of these instructions must be filled in by authorised personnel and attached to the pump in a visible position.

**Caution** *If a pump has been used for a medium which is injurious to health or toxic, the pump will be classified as contaminated.*

If Grundfos Water Treatment is requested to service the pump, it must be ensured that the pump is free from substances that can be injurious to health or toxic. If the pump has been used for such substances, the pump must be cleaned before it is returned.

If proper cleaning is not possible, all relevant information about the chemical must be provided.

If the above is not fulfilled, Grundfos Water Treatment can refuse to accept the pump for service. Possible costs of returning the pump are paid by the customer.

The safety declaration can be found at the end of these instructions.

*The replacement of the power supply cable must be carried out by an authorised Grundfos service workshop.*

**Caution**

### 4. Technical data

#### 4.1 Identification

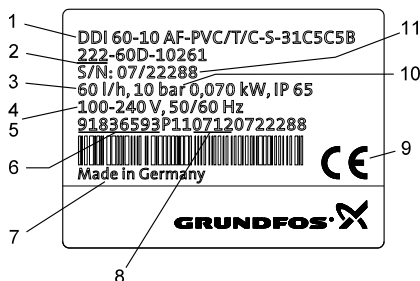

Fig. 1 DDI 209 nameplate

| Pos. | Description                      |
|------|----------------------------------|
| 1    | Type designation                 |
| 2    | Model                            |
| 3    | Maximum capacity [l/h]           |
| 4    | Voltage [V]                      |
| 5    | Frequency [Hz]                   |
| 6    | Product number                   |
| 7    | Country of origin                |
| 8    | Year and week code               |
| 9    | Marks of approval, CE mark, etc. |
| 10   | Maximum pressure [bar]           |
| 11   | Serial number                    |

TM03 8687 2207

## 4.2 Type key

**Example:** DDI 2- 16 AR PVC /V /G -F -3 1 3 B1 B

### Type range

DDI

### Maximum flow [l/h]

### Maximum counter-pressure [bar]

### Control variant

AR Standard  
 AF AR with Flow Monitor  
 AP AR with PROFIBUS  
 APF AR with Flow Monitor and PROFIBUS

### Dosing head variant

PP Polypropylene  
 PV PVDF (polyvinylidene fluoride)  
 PVC Polyvinyl chloride  
 SS Stainless steel, DIN 1.4401  
 PP-P3 PP with Plus<sup>3</sup> system  
 PVC-P3 PVC with Plus<sup>3</sup> system  
 PP-L PP + integrated diaphragm leakage detection  
 PV-L PV + integrated diaphragm leakage detection  
 PVC-L PVC + integrated diaphragm leakage detection  
 SS-L SS + integrated diaphragm leakage detection

### Gasket material

E EPDM  
 V FKM  
 T PTFE

### Valve ball material

C Ceramics  
 G Glass  
 T PTFE  
 SS Stainless steel, DIN 1.4401

### Control panel position

F Front-mounted  
 T Top-mounted

### Supply voltage

3 1 x 100-240 V, 50/60 Hz  
 1 24 V DC

### Mains plug

X No plug  
 F EU (Schuko)  
 B USA, Canada  
 I Australia, New Zealand, Taiwan  
 E Switzerland

### Connection, suction/discharge

B6 Pipe, 4/6 mm  
 3 Tube, 4/6 mm  
 A5 Tube, 5/8 mm  
 4 Tube, 6/9 mm  
 6 Tube, 9/12 mm  
 C4 Tube, 1/8" / 1/4"  
 R Tube, 1/4" / 3/8"  
 S Tube, 3/8" / 1/2"  
 A Threaded, Rp 1/4, female  
 V Threaded, 1/4" NPT, female  
 A9 Threaded, 1/2" NPT, male  
 B1 Tube, 6/12 mm/  
 cementing d. 12 mm  
 B2 Tube, 13/20 mm/  
 cementing d. 25 mm

### Valve type

1 Standard  
 2 Spring-loaded  
 0.05 bar suction opening pressure;  
 0.05 bar discharge opening pressure  
 3 Spring-loaded  
 0.05 bar suction opening pressure;  
 0.8 bar discharge opening pressure  
 4 Spring-loaded, discharge side only  
 0.8 bar opening pressure

### 4.3 General description

The DDI 209 is a dosing pump with a stepper motor and electronic power control. The pump is operated via the diagonal or horizontal display in a user-friendly menu structure.

The DDI 209 is available in various versions. See also section 1. *General information*.

In the general description, a distinction is made between pumps with dosing heads with the following features:

- manual deaeration (standard)
- Plus<sup>3</sup> system
- diaphragm leakage detection.

#### 4.3.1 DDI 209 with manual deaeration

Option:

The pump can also be equipped with the following:

- Flow Monitor
- interface for PROFIBUS.

The functions are described, but only apply to the relevant pump version.

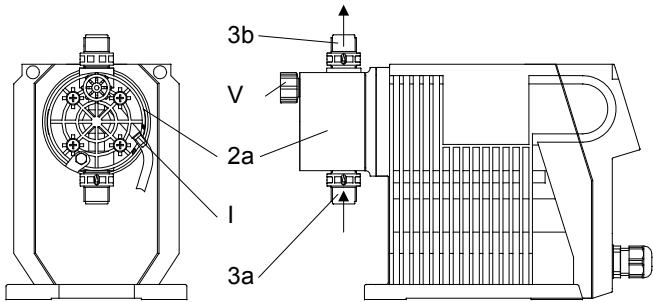
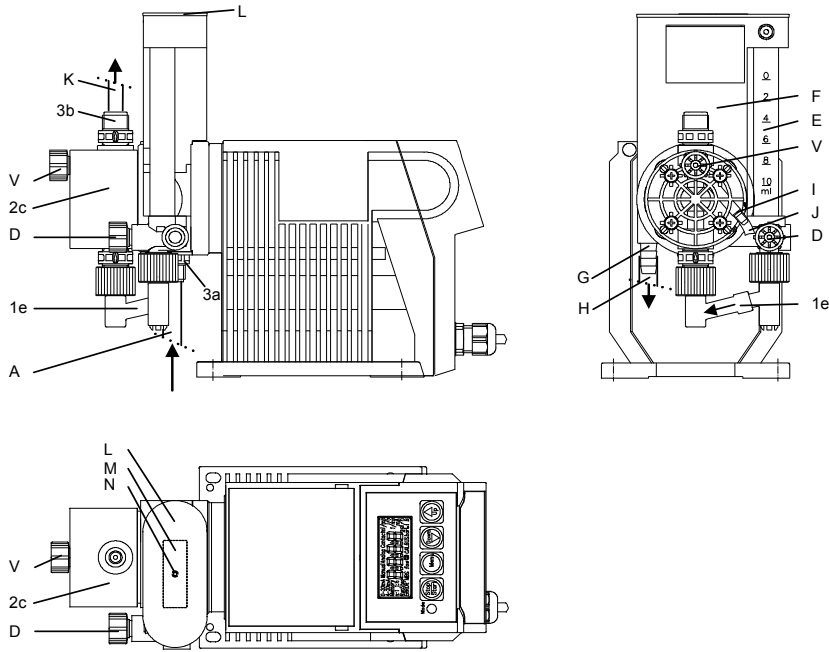

Fig. 2 DDI 209 with manual deaeration

| Pos. | Components                             |
|------|--|
| 3a   | Suction valve                          |
| 3b   | Discharge valve                        |
| 2a   | Dosing head with manual deaeration     |
| I    | Connection for deaeration line         |
| V    | Deaeration screw for manual deaeration |



**4.3.2 DDI 209 Plus<sup>3</sup> system with priming and calibration system for moderately degassing liquids (chlorine bleaching agents) (only for DDI 209 0.4-10 to DDI 209 5.5-10)**



**Fig. 3** DDI 209 Plus<sup>3</sup> system

| Pos. | Components   |
|------|--|
| 3a   | Suction valve                                      |
| 3b   | Discharge valve                                    |
| 2c   | Dosing head Plus <sup>3</sup> system               |
| I    | Connection for deaeration line                     |
| V    | Deaeration screw                                   |
| A    | Suction line from tank                             |
| 1e   | Line from calibration tube (E) to dosing head (2c) |
| D    | Isolating valve at calibration tube (E)            |
| E    | Calibration tube                                   |
| F    | Priming chamber                                    |
| G    | Connection for overflow line (H)                   |
| H    | Overflow line to tank (PVC tube 8/11)              |
| J    | Deaeration line to tank                            |
| K    | Discharge line                                     |
| L    | Cover  |
| M    | Adhesive label                                     |
| N    | Deaeration hole                                    |

**4.3.3 Functional principle of the Plus<sup>3</sup> system**

Plus<sup>3</sup> system in operation:

- The priming chamber (F) is filled with the dosing medium via the suction valve (3a).
  - The calibration tube (E) is filled from the priming chamber.
  - Unused dosing medium flows back into the tank via the overflow line (H).
- The dosing medium flows from the calibration tube (E) to the discharge valve (3b) via the small dosing diaphragm.

**Note** *The isolating valve (D) must be open during operation!*

TIM03 6590 4506

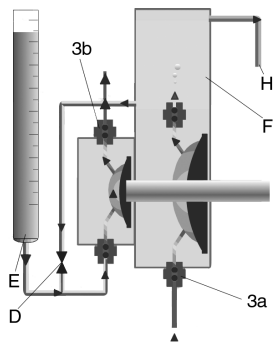

TM03 6214 4506

Fig. 4 Functional principle of the Plus<sup>3</sup> system

4.3.4 DDI 209 with diaphragm leakage detection

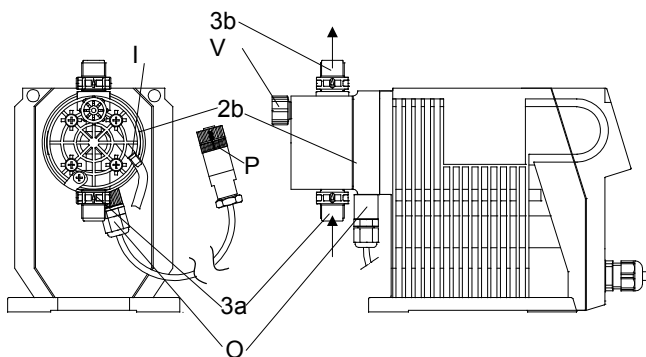

Fig. 5 DDI 209 with diaphragm leakage detection

TM03 6591 4506

**Pos. Components**

|    |   |
|----|---|
| 3a | Suction valve   |
| 3b | Discharge valve   |
| 2b | Dosing head with flange for diaphragm leakage detection |
| I  | Connection for deaeration line                          |
| V  | Deaeration screw for manual deaeration                  |
| O  | Opto-sensor   |
| P  | M12 plug for socket 1                                   |

#### 4.3.5 Functional principle of diaphragm leakage detection

Pumps with diaphragm leakage detection (MLS) have a special dosing head flange for an optoelectronic sensor. The pump is supplied with the diaphragm leakage sensor (MLS) already installed.

The optoelectronic sensor contains:

- infrared transmitter
- infrared receiver.



TM03 6216 4506

**Fig. 6** Diaphragm leakage sensor (MLS)

If the diaphragm leaks,

- the liquid enters the dosing head flange.
- the light refraction changes.
- the sensor emits a signal.

The electronics operates two contacts, which can be used, for example, to trigger an alarm signal or to switch off the pump.

#### 4.3.6 Flow Monitor for dosing control

The pressure sensor (Flow Monitor pump option) is used as a dosing controller and to monitor the pressure for the whole power ranges.

The Flow Monitor for dosing control consists of a pressure sensor integrated in the dosing head.

The pressure sensor is available as Flow Monitor pump option. The pressure sensor is fitted to the pump on delivery. Upgrades are not possible.

**Note**

***Pressure control is primarily used to protect the pump. This function is not a substitute for the overflow valve.***

#### 4.3.7 HV variant for liquids which are more viscous than water

All HV-variant pumps are equipped with spring-loaded valves, some have a larger nominal diameter and adapters.

**Note**

***Note that the HV-variant pump has other dimensions and that other connection line dimensions might be required!***

## 4.4 Dimensional sketches

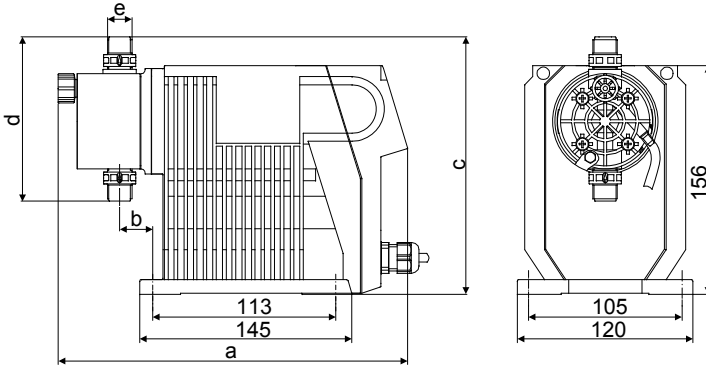
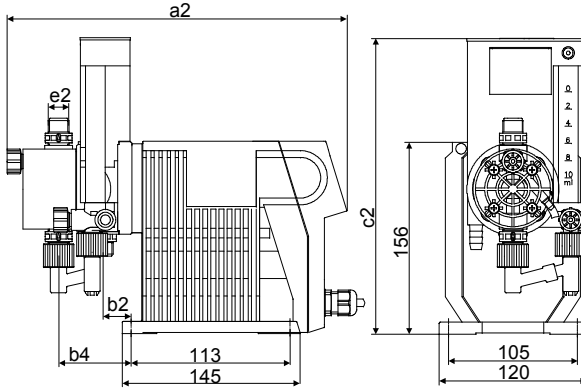

Fig. 7 DDI 209

## Dimensions for DDI 209

|            | a<br>[mm] | b<br>[mm] | c<br>[mm] | d<br>[mm] | e     | c HV<br>[mm] | d HV<br>[mm] | e HV  |
|------------|-----------|-----------|-----------|-----------|-------|--------------|--------------|-------|
| DDI 0.4-10 | 239       | 23        | 175.5     | 112       | G 3/8 | 175.5        | 112          | G 3/8 |
| DDI 2.2-16 | 239       | 23        | 175.5     | 112       | G 3/8 | 207.5        | 176          | G 5/8 |
| DDI 2.5-10 | 239       | 23        | 175.5     | 112       | G 3/8 | 207.5        | 176          | G 5/8 |
| DDI 5.5-10 | 239       | 23        | 175.5     | 112       | G 3/8 | 207.5        | 176          | G 5/8 |
| DDI 13.8-4 | 240       | 29        | 185       | 133       | G 5/8 | 185          | 133          | G 5/8 |
| DDI 20-3   | 240       | 29        | 185       | 133       | G 5/8 | 185          | 133          | G 5/8 |

TM03 6592 4506



TM03 6593 4506

Fig. 8 DDI 209 with Plus<sup>3</sup> system

**Dimensions for DDI 209 with Plus<sup>3</sup> system (only DDI 0.4-10 - DDI 5.5-10)**

|            | a2<br>[mm] | b2<br>[mm] | c2<br>[mm] | d2<br>[mm] | e2    |
|------------|------------|------------|------------|------------|-------|
| DDI 0.4-10 | 276        | 25         | 61         | 240        | G 3/8 |
| DDI 2.2-16 | 276        | 25         | 61         | 240        | G 3/8 |
| DDI 2.5-10 | 276        | 25         | 61         | 240        | G 3/8 |
| DDI 5.5-10 | 276        | 25         | 61         | 240        | G 3/8 |

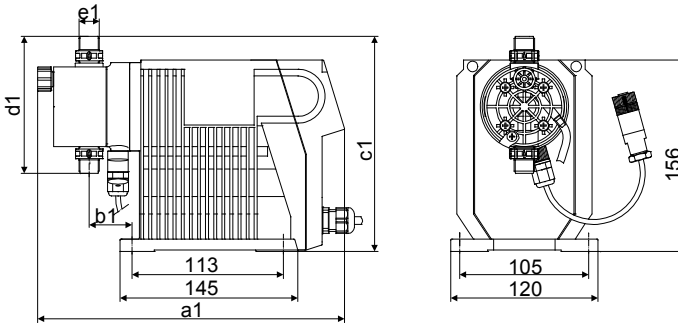

TM03 6594 4506

Fig. 9 DDI 209 with diaphragm leakage detection

**Dimensions for DDI 209 with diaphragm leakage detection**

|            | a1<br>[mm] | b1<br>[mm] | c1<br>[mm] | d1<br>[mm] | e1    | c1 HV<br>[mm] | d1 HV<br>[mm] | e1 HV |
|------------|------------|------------|------------|------------|-------|---------------|---------------|-------|
| DDI 0.4-10 | 250        | 34         | 175.5      | 112        | G 3/8 | 175.5         | 112           | G 3/8 |
| DDI 2.2-16 | 250        | 34         | 175.5      | 112        | G 3/8 | 207.5         | 176           | G 5/8 |
| DDI 2.5-10 | 250        | 34         | 175.5      | 112        | G 3/8 | 207.5         | 176           | G 5/8 |
| DDI 5.5-10 | 250        | 34         | 175.5      | 112        | G 3/8 | 207.5         | 176           | G 5/8 |
| DDI 13.8-4 | 251        | 40         | 185        | 133        | G 5/8 | 185           | 133           | G 5/8 |
| DDI 20-3   | 251        | 40         | 185        | 133        | G 5/8 | 185           | 133           | G 5/8 |

## 4.5 Weight

| Pump type               | Dosing head material        | Weight [kg] |
|-------------------------|-----------------------------|-------------|
| DDI 0.4-10 - DDI 2.5-10 | PVC, PP, PVDF               | 2.3         |
| DDI 0.4-10 - DDI 2.5-10 | Stainless steel, DIN 1.4571 | 3.5         |
| DDI 5.5-10              | PVC, PP, PVDF               | 2.4         |
| DDI 5.5-10              | Stainless steel, DIN 1.4571 | 3.6         |
| DDI 13.8-4 - DDI 20-3   | PVC, PP, PVDF               | 2.6         |
| DDI 13.8-4 - DDI 20-3   | Stainless steel, DIN 1.4571 | 3.6         |

## 4.6 Materials

### Pump housing material

Pump and control unit housing: s PS FR GF 22 (glass-fibre-reinforced polystyrene).

### Pressure sensor (Flow Monitor)

Sensor: Aluminium oxide Al<sub>2</sub>O<sub>3</sub> (96 %).

O-rings: FKM, EPDM or PTFE.



#### Warning

**Observe the manufacturer's safety instructions when handling chemicals!**

**The resistance of the parts that come into contact with the media depends on the media, media temperature and operating pressure. Ensure that parts in contact with the medium are chemically resistant to the dosing medium under operating conditions!**

#### Caution

**Further information on resistance with regard to the media, media temperature and operating pressure is available on request.**

#### Note

## 4.7 Control unit

### Functions of pumps with control unit

- "continuous operation" button for function test and dosing head deaeration
- memory function (stores a maximum of 65,000 pulses)
- two-stage tank-empty signal (e.g. via Grundfos tank-empty sensor)
- stroke signal/pre-empty signal (adjustable)
- dosing controller function (only with sensor – optional)
- diaphragm leakage detection (only with sensor – optional)
- access-code-protected settings
- remote on/off
- Hall sensor (for motor monitoring)
- calibration (adjust the pump to local operating conditions)
- dosing capacity display (can be reset)
- operating hours counter (cannot be reset)
- interface: PROFIBUS (optional).

Operating modes:

- manual input/display of the dosing flow in l/h or gal/h. Quasi continuous dosing (short suction stroke, dosing stroke as long as possible).
- contact signal control input/display in ml/contact, most constant dosing
- current signal control 0-20 mA / 4-20 mA Adjustment of volumetric flow proportional to the current signal (displayed in l/h). Weighting of current input/output.
- batch dosing setting the dosing capacity and dosing flow per batch triggered manually or by an external contact signal
- batch dosing with timer functions
  - setting the dosing capacity and dosing flow per batch
  - setting the start time for first batch
  - setting the repeat time for subsequent batches.
- slow mode (for viscous media) long suction stroke.

### Inputs and outputs

#### Inputs

|  |  |
|--|--|
| Contact signal                                 | Maximum load: 12 V, 5 mA<br>Minimum pulse length: 10 ms<br>Minimum pause time: 20 ms |
| Current 0-20 mA                                | Maximum load: 22 Ω   |
| Remote on/off                                  | Maximum load: 12 V, 5 mA   |
| Tank-empty signal                              | Maximum load: 12 V, 5 mA   |
| Dosing controller and diaphragm leakage sensor |  |

#### Outputs

|                  |   |
|------------------|---|
| Current 0-20 mA  | Maximum load: 350 Ω                           |
| Error signal     | Maximum ohmic load:<br>50 VDC / 75 VAC, 0.5 A |
| Stroke signal    | Contact time/stroke: 200 ms                   |
| Pre-empty signal | Maximum ohmic load:<br>50 VDC / 75 VAC, 0.5 A |

### 4.7.1 Interface (optional)

- PROFIBUS.

## 5. Installation

### 5.1 General information on installation



#### Warning

Observe the specifications for the installation location and range of applications described in sections 1. General information and 5.2 Installation location.



#### Warning

Faults, incorrect operation or faults on the pump or system can, for example, lead to excessive or insufficient dosing, or the permissible pressure may be exceeded. Consequential faults or damage must be evaluated by the operator and appropriate precautions must be taken to avoid them!

#### Caution

The DDI 0.4-10 (not with Plus<sup>3</sup> system) should be operated with flooded suction!

### 5.2 Installation location

#### 5.2.1 Space required for operation and maintenance

#### Note

The pump must be installed in a position where it is easily accessible during operation and maintenance work.

The control elements must be easily accessible during operation.

Maintenance work on the dosing head and the valves must be carried out regularly.

Provide sufficient space for removing the dosing head and the valves.

#### 5.2.2 Permissible ambient influences

Permissible ambient temperature: 0 °C to +40 °C.

Permissible air humidity: max. relative humidity: 92 % (non-condensing).

**The installation site must be under cover!**

**Ensure that the enclosure class of motor and pump is not affected by the atmospheric conditions.**

#### Caution

**Pumps with electronics are only suitable for indoor use!  
Do not install outdoors!**

#### 5.2.3 Mounting surface

The pump must be mounted on a flat surface.

### 5.3 Mounting

#### Caution

**Carefully tighten the screws, otherwise the plastic housing may be damaged.**

#### 5.3.1 Horizontal mounting

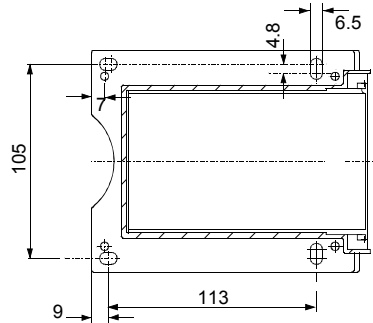

Fig. 10 Drilling scheme

- Use four M6 screws to mount the pump on the tank or on a console so that the suction valve is at the bottom and the discharge valve is at the top (dosing always flows upwards).

#### 5.3.2 Vertical mounting

#### Note

**Pumps with Plus<sup>3</sup> system must not be mounted vertically!**

- Mount the pump on a vertical surface (e.g. a wall) using four M6 screws.
- Unscrew the dosing head (four inner dosing head screws (1q + 2q)).
- Turn the intermediate ring (4q) so that the discharge hole points downwards.
- Turn the dosing head 90 ° so that the suction valve is at the bottom and the discharge valve is at the top (dosing always flows upwards).
- Cross-tighten the screws using a torque wrench. Maximum torque:  
DDI 0.4 - DDI 5.5: 2.1 Nm.  
DDI 13.8 - DDI 20: 2.5 Nm.

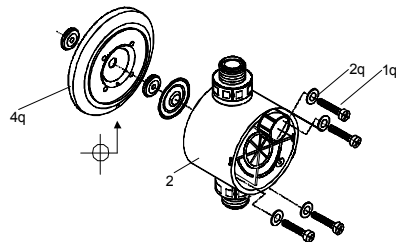

Fig. 11 Vertical mounting

#### 5.3.3 Diaphragm leakage detection

With diaphragm leakage detection:

- Screw the sensor from the bottom into the opening in the dosing head flange.

TM03 6223 4506

TM03 6223 4506

### 5.4 Installation examples

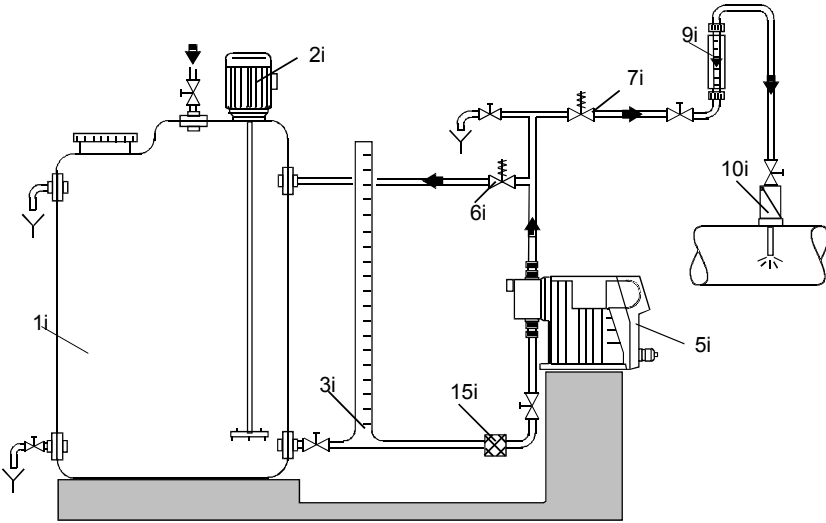
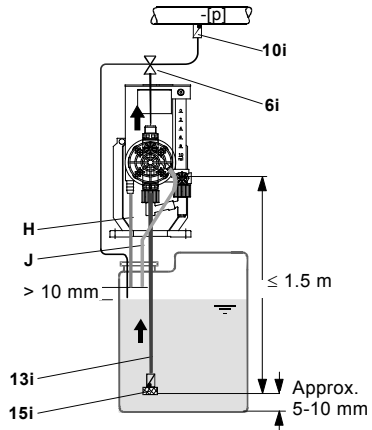

**Fig. 12** Installation example of pump with manual deaeration

| Pos. | Components             |
|------|------------------------|
| 1i   | Dosing tank            |
| 2i   | Electric agitator      |
| 3i   | Extraction device      |
| 5i   | Dosing pump            |
| 6i   | Relief valve           |
| 7i   | Pressure-loading valve |
| 9i   | Calibration tube       |
| 10i  | Injection unit         |
| 15i  | Filter                 |

For pumps with Plus<sup>3</sup> system:

- No flooded suction!
- Minimum injection pressure on the discharge side.
- The pressure at the discharge valve must be at least 1 bar higher than the pressure at the suction valve.



**Fig. 13** Installation example of pump with Plus<sup>3</sup> system

TM03 6225 4506

TM03 6226 4506



### 5.5 Installation tips

- For non-degassing media with a viscosity similar to water, the pump can be mounted on the tank (observe the permissible suction lift).
- Flooded suction preferred (not possible with Plus<sup>3</sup> system).
- For media with a tendency to sedimentation, install the suction line with filter (15i) so that the suction valve remains a few millimetres above the possible level of sedimentation.

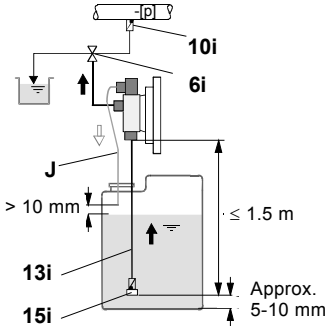

Fig. 14 Tank installation

#### With open outflow of the dosing medium or low counter-pressure

A positive pressure difference of at least 1 bar must be ensured between the counter-pressure at the injection point and the pressure of the dosing medium at the pump suction valve.

- If this cannot be ensured, install a pressure-loading valve (7i) immediately before the outlet or the injection unit.

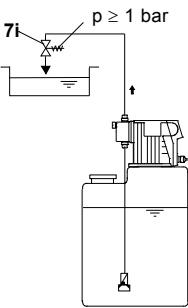

Fig. 15 Installation with pressure-loading valve

- To avoid the siphon effect, install a pressure-loading valve (7i) in the discharge line and, if necessary, a solenoid valve (14i) in the suction line.

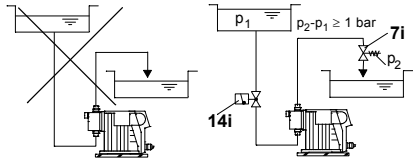

Fig. 16 Installation to avoid the siphon effect

- To protect the dosing pump against excessive pressure build-up, install a relief valve (6i) in the discharge line.
- For degassing media:
  - Flooded suction (not with Plus<sup>3</sup> system).
  - Install a filter (15i) in the suction line to prevent the valves being contaminated.

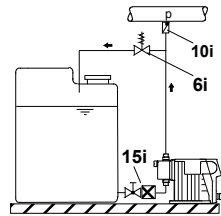

Fig. 17 Installation with relief valve and filter

- When installing the suction line, observe the following:
  - Keep the suction line as short as possible. Prevent it from becoming tangled.
  - If necessary, use swept bends instead of elbows.
  - Always route the suction line up towards the suction valve.
  - Avoid loops as they may cause air bubbles.

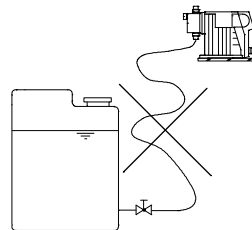

Fig. 18 Installation of suction line

TM03 6227 4506

TM03 6230 4506

TM03 6231 4506

TM03 6229 4506

TM03 6232 4506

- In the case of long discharge lines, install a non-return valve (12i) in the discharge line.

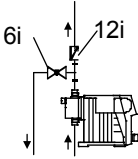

Fig. 19 Installation with non-return valve

TMO3 6233 4506

## 5.6 Tube / pipe lines

### 5.6.1 General

#### Warning

To protect the dosing pump against excessive pressure build-up, install a relief valve in the discharge line.



All lines must be free from strain! Avoid loops and buckles in the tubes! Keep the suction line as short as possible!

The flow must run in the opposite direction to gravity!

Observe the manufacturer's safety instructions when handling chemicals!

The resistance of the parts that come into contact with the media depends on the media, media temperature and operating pressure. Ensure that parts in contact with the media are chemically resistant to the dosing medium under operating conditions! Only use the specified line types!

#### Caution

### With Plus<sup>3</sup> system

- Use the suction line with foot valve and empty signal.
- For degassing media, maintain a maximum suction lift of 1.5 m.
- Open the isolating valve on the calibration system.

### Maximum suction line length

- 5 m for standard pumps or pumps with Plus<sup>3</sup> system when dosing media with a viscosity similar to water.
- 1.2 m when dosing media with a higher viscosity than water.

### 5.6.2 Sizing of tube / pipe lines

#### Warning

PVC tube DN 4 is not suitable for use as a discharge line!



Connect PE tube DN 4 on the discharge side!

#### Warning



Observe the pressure stage of the used lines. The maximum permissible inlet pressure and the pressure stage of the discharge lines must not be exceeded!

### Minimum internal diameter

| Pump type  | Pump version |                                      |
|------------|--------------|--------------------------------------|
|            | Standard     | HV variant                           |
|            | [mm]         | [mm]                                 |
| DDI 0.4-10 | 4            | Suction side: 5<br>Discharge side: 4 |
| DDI 2.2-16 |              |                                      |
| DDI 2.5-10 | 4            | 6                                    |
| DDI 5.5-10 |              |                                      |
| DDI 13.8-4 | 6            | Suction side: 9<br>Discharge side: 6 |
| DDI 20-3   |              |                                      |

### 5.6.3 Connecting the suction and discharge lines

- Connect the suction line to the suction valve (3a).
  - Install the suction line in the tank so that the foot valve remains approximately 5 to 10 mm above the bottom of the tank or the possible level of sedimentation.
- Connect the discharge line to the discharge valve (3b).

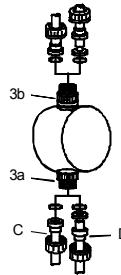

Fig. 20 Connecting the suction and discharge lines

| Pos. | Components      |
|------|-----------------|
| 3a   | Suction valve   |
| 3b   | Discharge valve |
| C    | Pipe connection |
| D    | Tube connection |

TMO3 6235 4506

**5.6.4 Connecting the overflow and deaeration lines**



**Warning**  
**Observe chemical resistance!**

**Note**

*HV-variant pumps have an assisting suction. In this case, prepare (cut) the deaeration line, but do not connect it yet!*

The pump has a deaeration line (PVC 4/6).

- Connect the deaeration line (J) to the connection for the deaeration line (I).

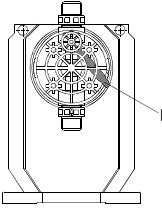

**Fig. 21** Connection for the deaeration line

TM03 6237 4506

**For pumps with Plus<sup>3</sup> system**

The pump has a deaeration line (PVC 4/6).

- Connect the deaeration line (J) to the connection for the deaeration line (I).
- Connect the overflow line (H) (PVC tube 8/11) to the connection (G).

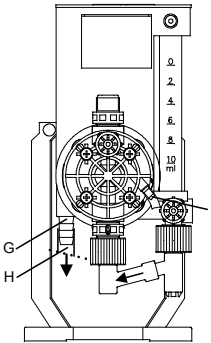
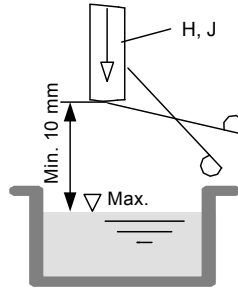

**Fig. 22** Plus<sup>3</sup> system

TM03 6238 4506

**5.6.5 Installing the overflow and deaeration lines**

- Shorten the overflow line (H) and deaeration line (J) to at least 10 mm above the maximum tank level.
- Insert the overflow line (H) and deaeration line (J) downwards into the dosing tank or collection container. Avoid loops.



**Fig. 23** Overflow and deaeration lines

TM03 6239 4506

**Dosing medium can leak from the overflow and deaeration lines. Route both lines into a collection container or the tank!**

**Caution**

**Do not immerse the overflow line and deaeration line in the dosing medium!**

**Caution**

**Observe the pressure limits specified in section 1. General information!**

**6. Electrical connections**

Make sure that the pump is suitable for the electricity supply on which it will be used.

**Warning**

**Electrical connections must only be carried out by qualified personnel!**

**Disconnect the power supply before connecting the power supply cable and the relay contacts!**

**Observe the local safety regulations!**



**Warning**

**The pump housing must only be opened by personnel authorised by Grundfos!**



**Warning**

**Protect the cable connections and plugs against corrosion and humidity.**

**Only remove the protective caps from the sockets that are being used.**



**Caution**

**The power supply must be electrically isolated from the signal inputs and outputs.**

## 6.1 Connecting the signal lines for DDI 209

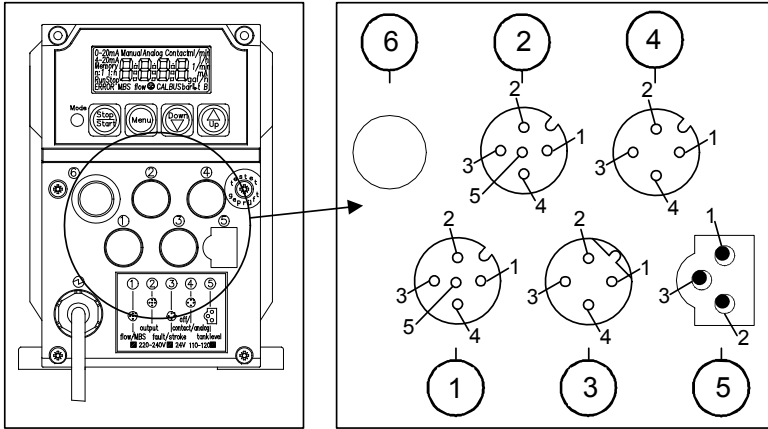

Fig. 24 DDI 209 connection diagram

### 6.1.1 Diaphragm leakage signal

#### Socket 1

For diaphragm leakage signal (MLS).

The diaphragm leakage signal is pre-assembled with an M12 plug for socket 1.

- Connect the cables according to the table below.

| Socket 1 | Used for / wire colours         |              |                          |
|----------|---------------------------------|--------------|--------------------------|
|          | Diaphragm leakage signal (MLS)* |              |                          |
| Pin      | Assignment                      | Cable 0.8 m  | Cable 3 m (without plug) |
| 1        | + 12 V                          |              |                          |
| 2        | MLS / GND                       | White        | White                    |
| 3        | MLS supply                      | Blue         | Yellow                   |
| 5        | MLS output                      | Green/yellow | Green                    |

\* MLS is an abbreviation of the function in German language "Membranleckagesignalisierung" = diaphragm leakage signalling

### 6.1.2 Current output / Flow Monitor

#### Socket 2

For pressure sensor for Flow Monitor option.

The pressure sensor is supplied ready-made with M12 plug for socket 2.

The current output indicates the current dosing flow and can be weighted independently of the selected operating mode. See section 9.6.4 *Weighting of current input/output*.

| Socket 2 |                       | Cable        | Used for           |              |
|----------|-----------------------|--------------|--------------------|--------------|
| Pin      | Assignment            | Wire colour  | +/- current output | Flow Monitor |
| 1        | + 5 V                 | Brown        |                    | Brown        |
| 3        | Pressure sensor input | Blue         |                    | Blue         |
| 4        | Current output        | Black        | +                  |              |
| 5        | GND                   | Green/yellow | -                  | Grey         |

**Pressure sensor (Flow Monitor):**  
**If socket 2 is also used for current output, the plug set (product number 96645265) has to be applied as described in section 6.1.6 Accessories: cable and plug for DDI 209.**

Note

### 6.1.3 Stroke/pulse signal / pre-empty signal / error signal

#### Socket 3

Electrically isolated output for stroke/pulse signal or pre-empty signal and error signal.

| Socket 3 |   | Cable       | Used for                               |              |
|----------|---|-------------|--|--------------|
| Pin      | Assignment                                      | Wire colour | Stroke/pulse signal / pre-empty signal | Error signal |
| 1        | Error signal contact                            | Brown       |  | x            |
| 2        | Stroke/pulse signal or pre-empty signal contact | White       | x                                      |              |
| 3        | Stroke/pulse signal or pre-empty signal contact | Blue        | x                                      |              |
| 4        | Error signal contact                            | Black       |  | x            |

#### 6.1.4 Remote on/off / contact input / current input

##### Socket 4

For the remote on/off input and contact input or current input.

If the remote on/off and contact inputs are to be used at the same time, wire 1 is assigned twice.

**Caution**

*For the connection of one cable, use a plug adapter with simple cable entry, for the connection of two cables, use a plug adapter with double cable entry, otherwise the protection will be lost!*

| Socket 4 |                     | Cable       | Used for            |               |                   |
|----------|---------------------|-------------|---------------------|---------------|-------------------|
| Pin      | Assignment          | Wire colour | Remote on/off input | Contact input | +/- current input |
| 1        | GND                 | Brown       | x                   | x             | -                 |
| 2        | Current input       | White       |                     |               | +                 |
| 3        | Remote on/off input | Blue        | x                   |               |                   |
| 4        | Contact input       | Black       |                     | x             |                   |

#### 6.1.5 Empty signal only / pre-empty and empty signal

##### Socket 5

For the empty signal only or pre-empty and empty signal input.

The suction lines with empty signal or pre-empty and empty signal are pre-assembled with a plug for socket 5.

| Socket 5 |                  | Used for     |                  |
|----------|------------------|--------------|------------------|
| Pin      | Assignment       | Empty signal | Pre-empty signal |
| 1        | Empty signal     | x            |                  |
| 2        | GND              | x            | x                |
| 3        | Pre-empty signal |              | x                |

## 6.1.6 Accessories: cable and plug for DDI 209

| Description   | Product numbers    |
|---|--------------------|
| 4-pole M12 plug, suitable for socket 3, with 2 m signal cable   | 96609017 / 321-206 |
| 4-pole M12 plug, suitable for socket 3, with 5 m signal cable   | 96609019 / 321-208 |
| 4-pole M12 plug, suitable for socket 4, with 2 m signal cable   | 96609014 / 321-205 |
| 4-pole M12 plug, suitable for socket 4, with 5 m signal cable   | 96609016 / 321-207 |
| 5-pole M12 plug set, suitable for socket 2, with coupling for pressure sensor (Flow Monitor) and 2 m of signal cable for the current output | 96645265 / 321-327 |
| 5-pole M12 plug, suitable for sockets 1, 2 and 4, screwed, without cable, with double cable entry   | 96609030 / 321-210 |
| 5-pole M12 plug, suitable for sockets 1, 2 and 4, screwed, without cable, with single cable entry   | 96609031 / 321-217 |
| Extension cable, 5 m with 5-pole coupling for M12 plug  | 96609032 / 321-223 |

## 6.2 Connecting the power supply cable

### Warning

**Disconnect the power supply before connecting the power supply cable!**



**Before connecting the power supply cable, check that the rated voltage stated on the pump nameplate corresponds to the local conditions! Do not make any changes to the power supply cable or plug!**

### Caution

**The pump can be automatically started by connecting the power supply!**

### Caution

**The assignment between the plug-and-socket connection and the pump must be labelled clearly (e.g. by labelling the socket outlet).**

- Do not switch on the power supply until you are ready to start the pump.

### 6.2.1 Versions without mains plug

### Warning



**The pump must be connected to an external clearly labelled mains switch with a minimum contact gap of 3 mm in all poles.**

- Connect the pump to the mains in accordance with local electrical installation regulations.

### Pump in 24 V version

- Connect the power supply cable according to the table below:

| Assignment | Wire colour  |
|------------|--------------|
|            | Brown        |
|            | Blue         |
|            | Green/yellow |

### Warning



**IP65 can only be ensured if the power supply cable is connected with IP65 protection.**

### 6.2.2 Version with mains plug

- Insert the mains plug in the mains socket.

## 7. Start-up / shutdown

### Warning



**Risk of chemical burns!**

**Wear protective clothing (gloves and goggles) when working on the dosing head, connections or lines!**

**Before each start-up, check the dosing head screws.**

**After initial start-up and after each time the diaphragm is changed, tighten the dosing head screws.**

### Caution

**After approximately 6-10 operating hours or two days, cross-tighten the dosing head screws using a torque wrench.**

**Maximum torque:**

**DDI 0.4 - DDI 5.5: 2.1 Nm.**

**DDI 13.8 - DDI 20: 2.5 Nm.**

## 7.1 Initial start-up / subsequent start-up

### 7.1.1 Checks before start-up

- Check that the rated voltage stated on the pump nameplate corresponds to the local conditions!
- Check that all connections are secure and tighten, if necessary.
- Check that the dosing head screws are tightened with the specified torque and tighten, if necessary.
- Check that all electrical connections are correct.

### With Plus<sup>3</sup> system

- Open the isolating valve (D) at the calibration tube.

### 7.1.2 Assisting suction for Plus<sup>3</sup> system

Pumps with Plus<sup>3</sup> system have an assisting suction.

- Fit the syringe and the piece of hose.



TM03 6242 4506

**Fig. 25** Assisting suction for Plus<sup>3</sup> system



#### **Warning**

**Ensure that the pump is stopped!**

### Sucking in dosing medium using the assisting suction for Plus<sup>3</sup> system

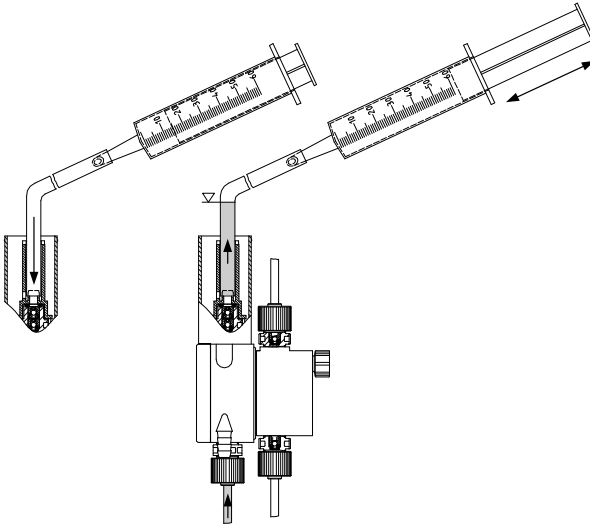

**Fig. 26** Sucking in the dosing medium

1. Remove the cover from the priming chamber.
2. Push the hose as far as it will go into the valve tube.
3. Draw up the syringe in order to create a perceptible low pressure, and hold the syringe in this position.
4. Dosing medium rises in the suction line, through the valve tube to the suction hose.
5. Relieve the syringe.
6. Remove the syringe and hose and empty.
7. Close the cover.
  - For HV-variant pumps, see section 7.1.3 *Assisting suction for HV variant*.
  - Pump without HV variant can now be started, see section 7.1.5 *Starting the pump*.

### 7.1.3 Assisting suction for HV variant

HV-variant pumps have an assisting suction.

- Fit the syringe and the piece of hose.

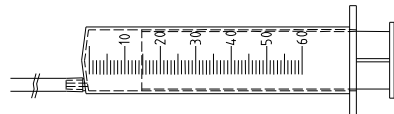

TM03 6243 4506

TM03 6244 4506

**Fig. 27** Assisting suction for HV variant



#### **Warning**

**Ensure that the pump is stopped!**



## Sucking in dosing medium using the assisting suction

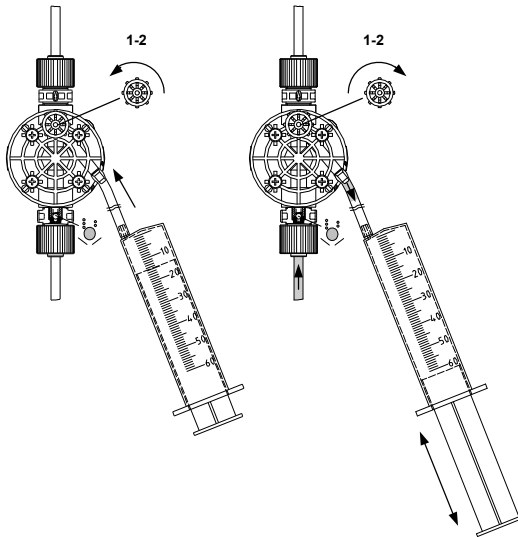

**Fig. 28** Sucking in the dosing medium

1. Attach the hose to the connection for the deaeration line.
2. Open the deaeration screw, 1 or 2 turns.
3. Draw up the syringe in order to create a perceptible low pressure, and hold the syringe in this position.
4. Dosing medium rises in the suction line, up to the suction hose.
5. Relieve the syringe.
6. Carefully remove the syringe with the suction hose.
7. Empty the syringe into the dosing tank.
8. Tighten the deaeration screw.
9. Attach the deaeration line to the connection for the deaeration line. Observe the instructions in section 5.6.4 *Connecting the overflow and deaeration lines*.
  - The pump can now be started, see section 7.1.5 *Starting the pump*.

### 7.1.4 Assisting suction for systems without Plus<sup>3</sup> system

At the dry suction/discharge valves:

1. Remove the suction line.
2. Hold a small container of water directly next to the suction valve and draw water until the dosing head is full.
3. Reinsert the suction line.

### 7.1.5 Starting the pump

1. Open the suction and discharge isolating valves, if installed.
2. Open the deaeration valve of the dosing head by approximately 1 turn.
3. Let the pump run in continuous operation:
  - Switch on the power supply.
  - Press the "Start/Stop" button and keep it pressed.
  - The pump switches to continuous operation at maximum stroke frequency.
4. Leave the pump running until the dosed medium is free of air bubbles and, for the Plus<sup>3</sup> system, until the calibration tube is full.
  - Leave the pump DDI 0.4-10 running in continuous operation for approximately 5 min.
5. Carefully close the deaeration valve.
  - The pump is now ready for operation.

### 7.1.6 After initial start-up of pumps with Plus<sup>3</sup> system

- After initial start-up, remove the adhesive label (M) from the cover (L), see figs 3 and 29.



Fig. 29 Adhesive label

### 7.1.7 Tightening dosing head screws

**After initial start-up and after each time the diaphragm is changed, tighten the dosing head screws.**

**After approximately 6-10 operating hours or two days, cross-tighten the dosing head screws using a torque wrench.**

**Caution**

**Maximum torque:**  
**DDI 0.4 - DDI 5.5: 2.1 Nm.**  
**DDI 13.8 - DDI 20: 2.5 Nm.**

## 7.2 Operating the pump

*To operate the pump, see sections 8. Operation and 10. Maintenance and, if necessary, section 11. Fault finding chart.*

**Note**

### 7.3 Shutdown

#### Warning

**Risk of chemical burns!**



**Wear protective clothing (gloves and goggles) when working on the dosing head, connections or lines!**

**Do not allow any chemicals to leak from the pump. Collect and dispose of all chemicals correctly!**

**Note**

**If possible, rinse the dosing head before shutting down the pump, e.g. by supplying it with water.**

#### 7.3.1 Switching off / uninstalling

1. Switch off the pump and disconnect it from the power supply.
2. Depressurise the system.
3. Take suitable steps to ensure that the returning dosing medium is safely collected.
4. Carefully remove all lines.
5. Uninstall the pump.

#### 7.3.2 Cleaning

1. Rinse all parts that have come into contact with the medium very carefully:
  - lines
  - valves
  - dosing head
  - diaphragm.
2. Remove any trace of chemicals from the pump housing.

#### 7.3.3 Storage

Storage of the pump:

1. After cleaning (see above), carefully dry all parts and reinstall the dosing head and valves, or
  2. change the valves and diaphragm.
- See section 10. Maintenance.

#### 7.3.4 Disposal

Disposal of the pump:

- After cleaning (see above), dispose of the pump in accordance with the relevant regulations.

TM03 6247 4506

## 8. Operation

*In the event of a diaphragm leakage, the dosing liquid may leak out of the hole in the intermediate flange between the pump and the dosing head.*

*The parts inside the housing are protected from the dosing liquid for a short time (depending on the type of liquid) by the housing sealing. It is necessary to check regularly (daily) if liquid is leaking out of the intermediate flange.*

**Caution**

*For maximum safety, we recommend the pump version with diaphragm leakage detection.*

### 8.1 Control and display elements

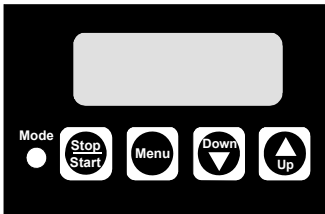







Fig. 30 Display of DDI 209

TM03 6257 4506

| Element  | Description  |
|--|--|
|   | <p>Light-emitting diode (LED)</p> <ul style="list-style-type: none"> <li>Lights up red when the pump is stopped.</li> <li>Lights up green when the pump is started and briefly goes out during a suction stroke.</li> <li>Lights up yellow when the pump is switched off remotely.</li> <li>Flashes red if an error signal is present.</li> <li>Goes out when the pump is in menu mode.</li> </ul> |
|    | <p>"Start/Stop"</p> <ul style="list-style-type: none"> <li>Use this button to start or stop the pump.</li> <li>Error signals can be acknowledged by pressing the "Start/Stop" button.</li> </ul>   |
|    | <p>Use the "Menu/Info" button to switch between the operating modes.</p>   |
|   | <p>Use the "Down" and "Up" buttons to change values in the display.</p>  |

### 8.1.1 Display test

A display test is automatically performed when the pump is switched on. All the segments of the LCD are switched on for 3 seconds and the software version number is then displayed for 2 seconds.

### 8.2 Switching on/off

*Before switching on the pump, check that it is installed correctly.*

**Caution**

*See sections 5. Installation and 7.1 Initial start-up / subsequent start-up.*

- To start the pump, switch on the power supply.
- To stop the pump, switch off the power supply.

### 8.3 Checking the dosing flow with Plus<sup>3</sup> system

For pumps with Plus<sup>3</sup> system, the current dosing flow can be checked during operation.



#### Warning

*Do not let the calibration tube (E) run empty!*

*Re-open the isolating valve (D) in due time!*

- Close the isolating valve (D) at the calibration tube (E).
- The supply from the priming chamber (F) is shut off and the calibration tube (E) is slowly emptied.
- Using a stop watch, measure the time (t in seconds) it takes to dose 3 or 10 ml of dosing medium, depending on pump type.
- Re-open the isolating valve (D) at the calibration tube (E).
- Calculate the dosing flow:

$$V = \frac{3 \text{ ml}}{t} = \frac{10,8}{t} \left[ \frac{l}{h} \right] \quad V = \frac{10 \text{ ml}}{t} = \frac{36}{t} \left[ \frac{l}{h} \right]$$

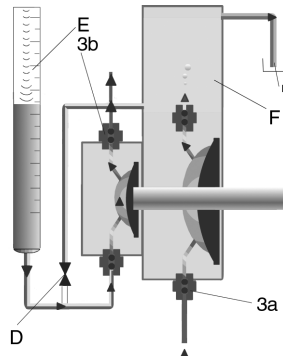
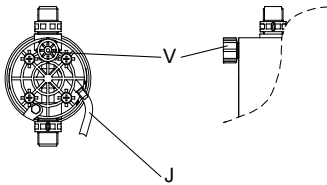

Fig. 31 Calculation of the dosing flow

TM03 6262 4506

## 8.4 Deaeration



TM03 6263 4506

**Fig. 32** Manual deaeration of the dosing head (while the pump is running)

1. Open the deaeration valve (V) of the dosing head by approximately 1 turn (2 turns with Plus<sup>3</sup> system).
2. Press the "Start/Stop" button and keep it pressed.
  - The pump switches to continuous operation.
3. Leave the pump running until the medium flowing from the deaeration line (J) is free of air bubbles.
4. Carefully close the deaeration valve.

## 8.5 Changing the tank with Plus<sup>3</sup> system

For pumps with Plus<sup>3</sup> system, the tank can also be changed during operation by using the supply of dosing medium in the priming chamber.

### Warning



**The dosing medium is constantly supplied from the overflow line while the pump is running. Take suitable steps to ensure that the dosing medium is safely collected!**

### Warning



**Risk of chemical burns! Wear protective clothing (gloves and goggles) when working on the dosing head, connections or lines!**

### Caution

**Do not let the calibration tube (E) run empty!**

### Changing the tank

1. Remove the suction line, overflow line and deaeration line from the empty tank.
  - The dosing medium is then supplied from the tank (F).
2. Insert the suction line, overflow line and deaeration line into the new tank.
3. Do **not** immerse the overflow line and deaeration line in the dosing medium. Route the lines downwards and without loops.

**There is only a limited amount of time available to change the tank, depending on the pump type and dosing flow, e.g. 30 seconds at a dosing flow of 6 l/h!**

### Note

**If air has been sucked in, briefly increase the stroke setting to 100 % and switch the pump to continuous operation.**

## 9. How to use the control unit

**First see sections 5. Installation, 7. Start-up / shutdown and 7.2 Operating the pump. Only the additional functions are described in this section.**

### Note

### 9.1 Menu levels

#### Menu levels used in the control unit

- **First function level:** for selecting and setting the operating modes of the pump (Manual, Contact, Analog), performing the batch and timer functions and starting the pump.
- **Second function level:** for setting and viewing additional functions, selecting and setting the batch and timer functions and setting the access code to protect the pump against unintentional or unauthorised access to pump settings.
- **Service level:** for setting the pump type and the unit of display for the dosing flow (l/h or gal/h) and setting the inputs and outputs.

#### Saving user settings

The pump settings are automatically saved approximately every 10 minutes and remain as they are even after the power supply has been switched off.

### 9.2 General functions of the control unit

#### 9.2.1 Deaeration and suction

If the "Start/Stop" button is pressed for longer than 1 second, the pump switches to continuous operation for as long as the button is held down (e.g. for suction or deaeration).

This happens regardless of the selected operating mode. (In batch or timer mode, the pump has to be stopped first.)

#### 9.2.2 Locking "run"

The pump can be locked to avoid manual stopping.

When activating this function (service level), the pump starts running with the present settings and cannot be stopped using the "Start/Stop" button.

It is still possible to acknowledge error messages using the "Start/Stop" button.

#### Stopping the pump when the locking "run" is activated

- If remote on/off is connected, use remote off.
- Disconnect the pump from the power supply.

### Note

**For "Batch manual", the "Run" button should not be locked as the pump then runs in continuous operation.**

#### 9.2.3 Two-stage tank-empty signal

This function is used to provide a warning when the tank is almost empty and to switch off the pump when the tank is empty. To use the pre-empty signal, ensure that the suction line is equipped with two float switches.

### Pre-empty signal

The pre-empty signal can be an error signal or a pre-empty signal at socket 3. For a pre-empty signal, relay 1 must be set to "Pre-empty signal".

See sections 6.1 *Connecting the signal lines for DDI 209* and 9.7.1 *Modifying the switch assignment*.

When the contact of the corresponding float switch closes,

- the error signal relay or pre-empty signal relay switches on, but the pump is not switched off.
- The LED flashes red.
- The empty-signal symbol flashes in the display.

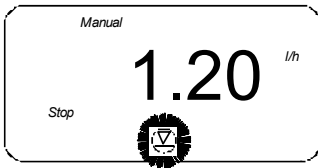

Fig. 33 Display: pre-empty signal

Once the error has been corrected,

- the error signal relay or pre-empty relay switches off.
- The pump returns to the state it was in before the error occurred.

### Empty signal

When the contact of the corresponding float switch closes,

- the pump is switched off.
- The error signal relay switches on.
- The LED flashes red.
- The empty-signal symbol lights up in the display.



Fig. 34 Display: empty-signal symbol

Once the error has been corrected,

- the pump starts running again (if it was running before).
- The error signal relay switches off.
- The pump returns to the state it was in before the error occurred.

### 9.2.4 Diaphragm leakage sensor (MLS)

As an option, the pump can be equipped with a sensor for diaphragm leakage detection.

The electronics automatically detects whether a sensor is connected. The following appears in the display.

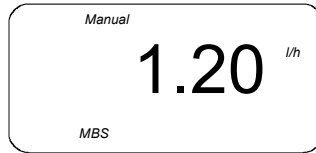

Fig. 35 Display: MLS sensor is connected

When a diaphragm leakage is detected by the sensor,

- the pump is switched off.
- The error signal relay switches on.
- The LED flashes red.
- "MBS" (MLS) and "ERROR" flash in the display.

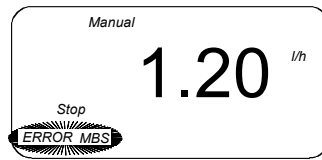

Fig. 36 Display: diaphragm leakage detected

Once the error has been corrected (the contact is no longer closed),

- press the "Start/Stop" button to acknowledge the error.
- The pump starts running again (if it was running before).
- The error signal relay switches off.
- The pump returns to the state it was in before the error occurred.

### 9.2.5 Hall sensor / motor monitoring

If the pump has existing strokes to process, the Hall sensor checks whether the drive is turning. If the drive motor is blocked, e.g. due to excess counter-pressure in the dosing system, this is detected and indicated by the integrated motor monitoring function.

- The error signal relay switches on.
- "1/min", "bar" and "ERROR" flash in the display.

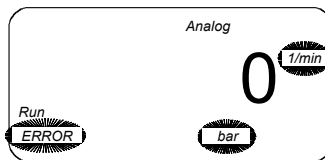

Fig. 37 Display: motor monitoring

- The pump is stopped.
- The red LED flashes.

For possible errors and their correction, see section 11. *Fault finding chart*.

Once the error has been corrected,

- press the "Start/Stop" button to acknowledge the error.

### 9.2.6 Remote on/off

The pump can be switched off remotely (e.g. from a control room).

- If switched off remotely, the pump does not respond to any input signals or to operator input. **Exception:** The pump can still be stopped and deaerated manually.
- "Stop" lights up in the display.
- The yellow LED lights up.
- When switched on remotely, the pump returns to the state it was in before it was switched off. If, for example, the pump was previously in "Stop" mode, it returns to this mode once it is switched on.

### 9.2.7 Memory function

Contact signals, which cannot be processed immediately, can be stored and subsequently made available to the pump for processing. A maximum of 65,000 contact signals can be stored.

- **Without memory:** If the pump is running when a contact signal is received, the signal is ignored. The pump performs the current dosing, then it is again ready to receive new contact signals, i.e. it rejects excess contacts.
- **With memory:** If the pump is running when a contact signal is received, the signal is stored in the memory. First, the pump performs the current dosing, then it processes the contact signals from the memory.

The contents of the memory are deleted:

- by switching off the power supply
- by switching the operating mode.

The contents of the memory are not deleted:

- by actuating the remote on/off contact
- by pressing the "Start/Stop" button
- by continuous operation.

Note

*The memory function can be enabled and disabled in the second function level.*

### 9.2.8 Flow Monitor

The pump can be equipped with a pressure sensor (Flow Monitor pump option).

Based on the pressure measured by the sensor and on the motor position, an indicator diagram is created. Possible dosing faults or the exceeding of the permissible counter-pressure are detected reliably and indicated by the display or the error message output.

The following errors are recognised:

- Pressure exceeded (the pump is stopped and restarts automatically when the pressure decreases).
- Dosing error (the pump doses 30 % to 100 % less due to a leaking discharge valve or suction valve, a clogged suction line or an air bubble in the dosing head).

Caution

*Depending on the operating conditions, it may be impossible to detect dosing errors which are caused by leaking suction valves!*

The dosing controller and dosing control functions can be switched on and off independently of each other. It is always possible to display the pressure that has been measured during operation whenever the pressure sensor is connected.

Note

*For information about operating the pump with the Flow Monitor, see section 9.10 Flow Monitor.*

## 9.3 Signal outputs

The control unit has the following signal outputs, e.g. in order to return a signal to the control room.

### 9.3.1 Current signal output

Note

*To use the control signal output, see section 9.9 Current signal control 0-20 mA / 4-20 mA.*

The current flow rate of the pump is output as a current signal.

- Current output 0-20 mA in the following mode:
  - Current control 0-20 mA.
- Current output 4-20 mA in the following modes:
  - Current control 4-20 mA
  - Manual
  - Contact
  - Batch dosing with manual/contact start
  - Timer with manual/contact start.

Note

*The current output is linear between 4 (0) mA at flow rate = 0 and 20 mA at maximum flow rate  $Q_{max}$ . (default setting) or the corresponding weighting value pair.*

### 9.3.2 Error signal

Used to return various error states to the control room.

### 9.3.3 Stroke signal / pre-empty signal / pulse input

Depending on the relay setting, the contact output receives a signal in these cases:

- for each complete stroke of the pump, or
- a pre-empty signal input, or
- each pulse input at the pump.

To set the relay, see section 9.7.1 *Modifying the switch assignment.*

## 9.4 First function level

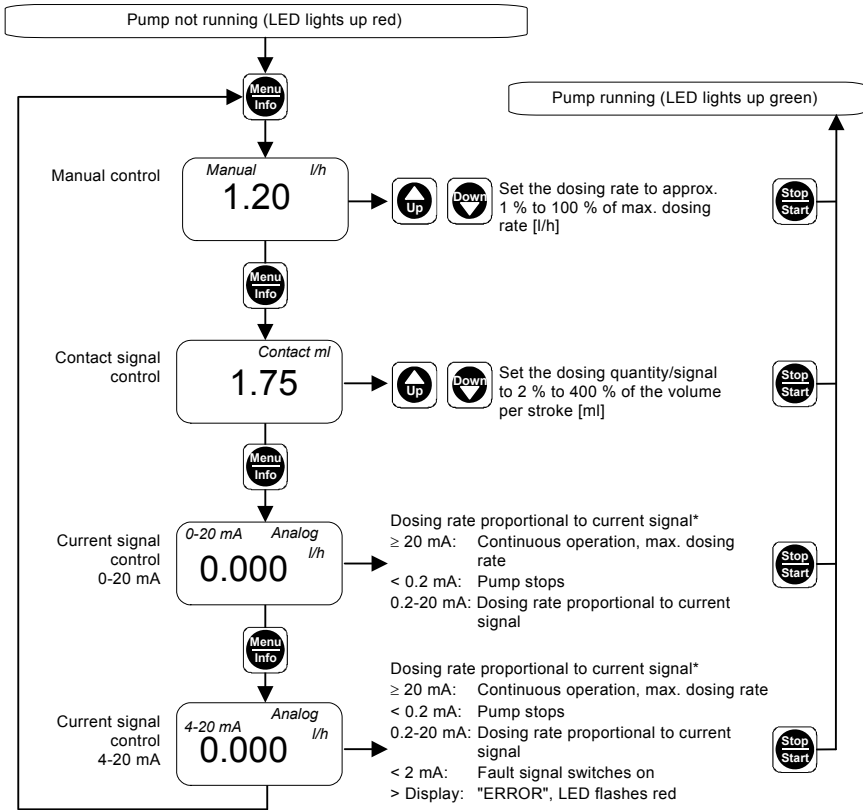

Fig. 38 First function level

\* You can modify the assignment between the current input and the flow rate. See section 9.9 *Current signal control 0-20 mA / 4-20 mA*.

### 9.4.1 Setting the operating modes

The operating modes are selected in the first function level, and settings can be made for the modes.

This function level can only be opened when the pump is stopped.

- When the pump is stopped (LED lights up red), press the "Menu/Info" button.
  - The first function level is opened.
- Navigate in the first function level by repeatedly pressing the "Menu/Info" button.
- Use the "Up" and "Down" buttons to modify the settings in the relevant menu as shown in fig. 38.
- Press the "Start/Stop" button to confirm the settings and to exit the first function level.
  - The pump is running (LED lights up green).

### 9.4.2 Manual control

#### Dosing with manual on/off and manually adjustable dosing flow

In this operating mode, all the settings are entered on the pump by the operator.

- Use the "Start/Stop" button to start or stop the pump.
- Use the "Up" and "Down" buttons to increase or decrease the flow rate. This can be done when the pump is stopped or when it is running.

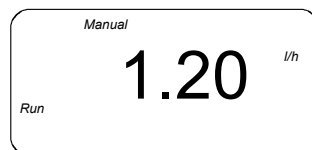

Fig. 39 Display: manual control

The maximum displayed/adjustable flow rate is automatically set according to the selected pump type and the calibrated stroke volume.

#### Input range for the flow rate

| Pump type  | $Q_{\min.}$<br>[l/h] | Resolution of flow rate                              |
|------------|----------------------|--|
| DDI 0.4-10 | 0.004*               | 1 ml/h   |
| DDI 2.2-16 | 0.025                |  |
| DDI 2.5-10 | 0.025                | 5 ml/h for $Q < 1$ l/h<br>10 ml/h for $Q \geq 1$ l/h |
| DDI 5.5-10 | 0.055                |  |
| DDI 13.8-4 | 0.140                | 20 ml/h for $Q < 10$ l/h                             |
| DDI 20-3   | 0.200                | 100 ml/h for $Q \geq 10$ l/h                         |

\* For counter-pressures lower than 3 bar,  $Q_{\min.}$  continuously increases from 0.004 l/h to 0.006 l/h.

#### 9.4.3 Contact signal control

**Note** *The pump must be started first in this operating mode (LED lights up green and "Run" appears in the display).*

- Use the "Start/Stop" button to start or stop the pump.

#### For continuous dosing in a process

For each signal received at the contact input of the pump (e.g. from a water meter with reed contact output), the pump doses the set dosing capacity. The dosing is continuously distributed between the incoming contacts via a controller. The maximum dosing capacity must not be exceeded.

#### Input range for the dosing capacity per contact

| Pump type  | Stroke volume<br>[ml] | Min. dosing capacity<br>(= 1/50 stroke/contact)<br>[ml] | Max. dosing capacity<br>(= 4 strokes/contact)<br>[ml] |
|------------|-----------------------|---|---|
| DDI 0.4-10 | 0.07                  | 0.001   | 0.28  |
| DDI 2.2-16 | 0.22                  | 0.004   | 0.86  |
| DDI 2.5-10 | 0.22                  | 0.004   | 0.88  |
| DDI 5.5-10 | 0.55                  | 0.011   | 2.20  |
| DDI 13.8-4 | 1.24                  | 0.025   | 4.96  |
| DDI 20-3   | 1.92                  | 0.039   | 7.86  |

Even if the pump receives more contact signals than it can process at the maximum flow rate, it only runs in continuous operation with a maximum stroke frequency of 180/min. (120/min. in slow mode).

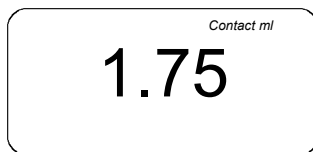

**Fig. 40** Display: contact signal control

Use the "Up" and "Down" buttons in the first function level to set the dosing volume for each contact signal.

- When the pump is stopped (LED lights up red), press the "Menu/Info" button.
  - The first function level is opened.
- Use the "Up" and "Down" buttons in the "contact signal control" menu to set the dosing volume per contact signal.
- Press the "Start/Stop" button to confirm the settings and to exit the first function level.
  - The pump is running (LED lights up green).

#### 9.4.4 Current signal control 0-20 mA / 4-20 mA

For current signal control, see section 9.9 *Current signal control 0-20 mA / 4-20 mA*.



## 9.5 Second function level

### 9.5.1 Opening / exiting the second function level

Open the second function level

- to set the access code,
- to enable or disable functions such as Flow Monitor or memory,
- to enter settings for operating modes such as batch mode,
- to display the total number of operating hours and total dosing capacity,
- to carry out a calibration, or
- to modify the assignment between the current input/output and dosing rate.

This function level can only be opened when the pump is stopped (LED lights up red).

### 9.5.2 Setting the access code

The access code is used to protect the pump against unintentional/unauthorised access to pump settings.

The default setting is 111. Code 111 gives access to all settings described in sections 9.4 *First function level* and 9.5 *Second function level*.

|             |
|-------------|
| <b>Note</b> |
|-------------|

***The "Start/Stop" button for stopping the pump is active with any code.***

1. Press the "Start/Stop" button while the pump is running (LED lights up green).
  - The pump is stopped (LED lights up red).
2. Press and hold down the "Menu/Info" button for 3 seconds.
  - The second function level is opened.
  - The input arrow appears in the display.
  - "C:111" (default setting is "111") or a user-defined code appears in the display.
3. Use the "Up" and "Down" buttons to set the code in the range between 1 and 999.

Code 111 is required to open the second function level.

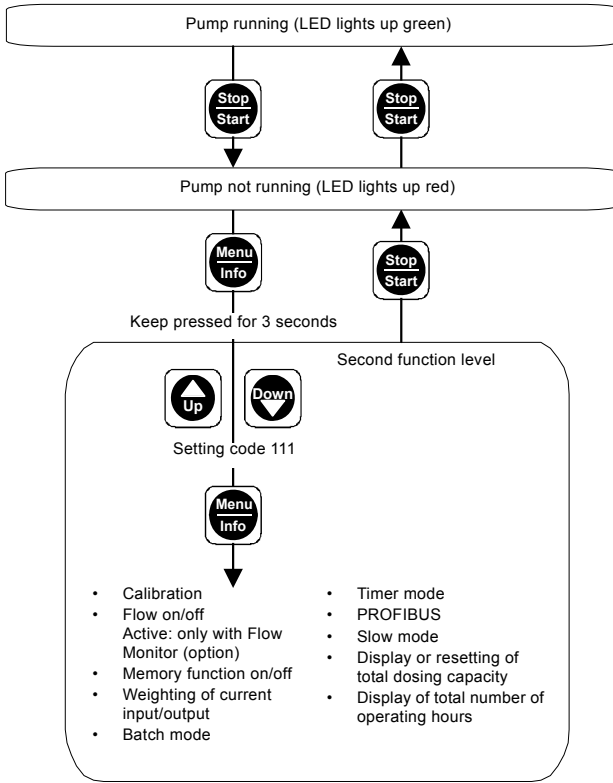

**Fig. 41** Opening / exiting the second function level

1. Navigate in the second function level by repeatedly pressing the "Menu/Info" button.
2. Use the "Up" and "Down" buttons to modify the settings in the relevant menu as shown in fig. 42.
3. Press the "Start/Stop" button to exit the second function level.

**Note**

***You can only change the parameters in the shown order. When the "Menu/Info" button is pressed again (after one run), the first function level opens automatically.***

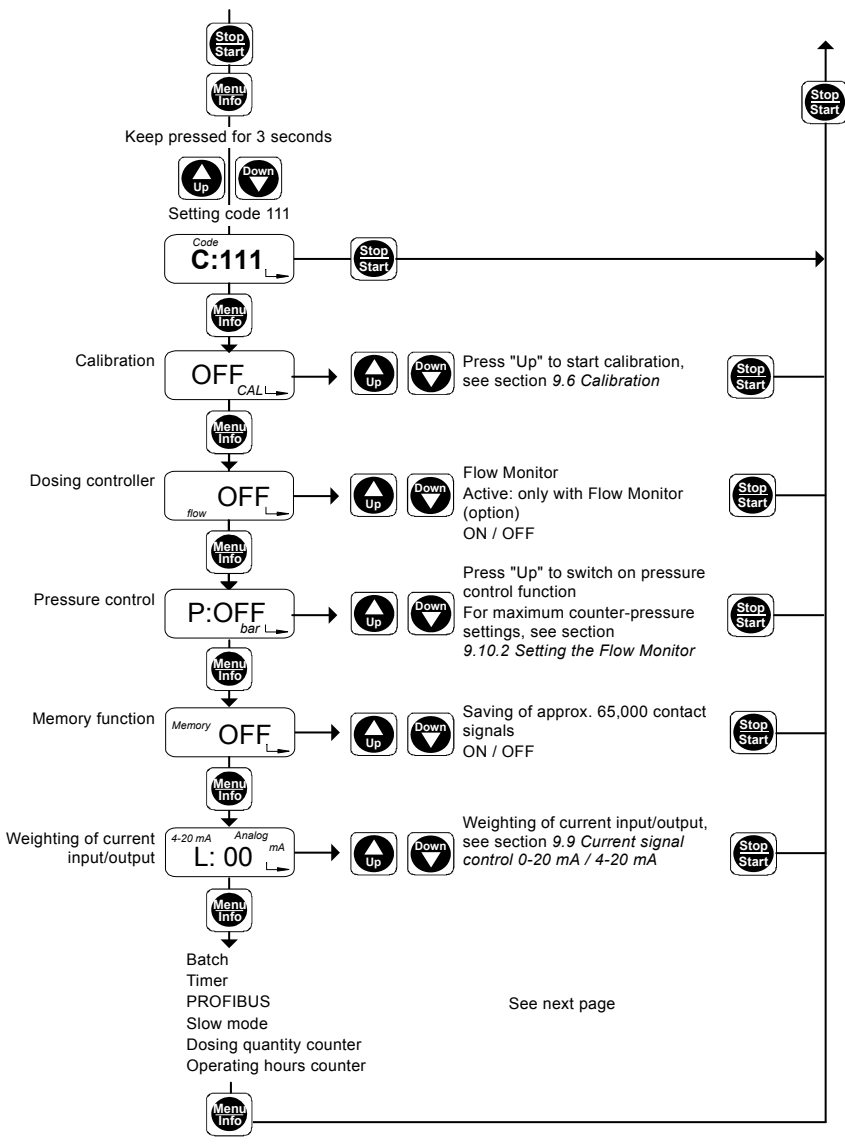

Fig. 42 Second function level, part 1

TM03 6609 4506

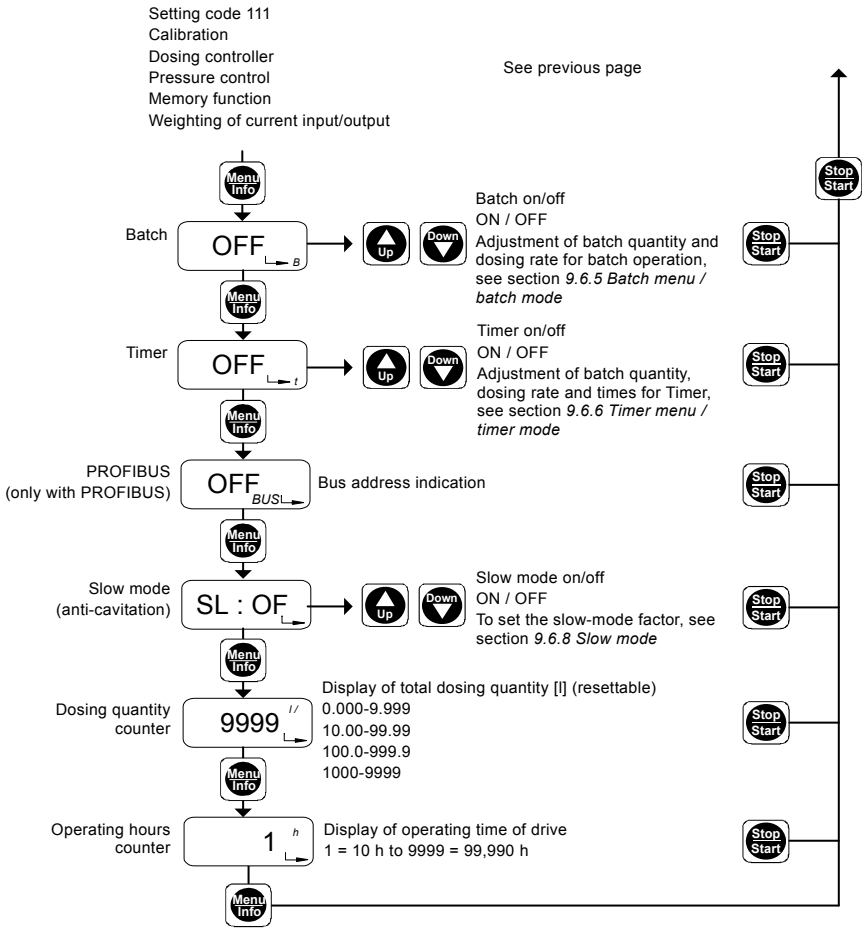

Fig. 43 Second function level, part 2

9.6 Calibration

The dosing flow display is set by default for an operating counter-pressure of 3 bar. Calibration can be used to set the pump flow to the actual operating conditions.

Calibrate the pump under normal operating conditions with the discharge line connected and at operating counter-pressure.

Note

*The dosed volume must be gauged in litres during calibration, e.g. by drawing the dosing medium from a gauged tank. (For an alternative for pumps with Plus<sup>3</sup> system, see section 9.6.1 Calibrating pumps with Plus<sup>3</sup> system (internal calibration)).*

Note

*Due to the small stroke volume of the DDI 0.4-10, calibration is essential for a precise dosing flow.*

*Before calibrating the DDI 0.4-10, deaerate the pump and then let it run for 15 minutes at operating counter-pressure with full stroke rate.*

"OFF CAL" appears in the display.

1. Press the "Up" button.
  - "ON CAL" appears in the display.
2. Press the "Start/Stop" button.
  - Calibration is started. The LED flashes green and "Run" flashes in the display.
- 200 strokes are performed by default. The number of strokes performed appears in the display.
- Press "Start/Stop" to stop at any stroke value.
  - The LED lights up red.
3. Press the "Start/Stop" button.
  - The current calibration value is displayed (not with replacement circuit boards!).

4. Use the "Up" and "Down" buttons to enter the calibration value (gauged volume in ml).
  - Press the "Menu/Info" button (confirm the setting and move on to the next menu item), or
  - press the "Start/Stop" button (confirm the setting and close the second function level).

**The calibration process does not change the setting for the assignment/weighting of the current input and output for the flow rate.**

**Note**

**If a current input or output is used, check after calibration to determine whether a new current weighting is required.**

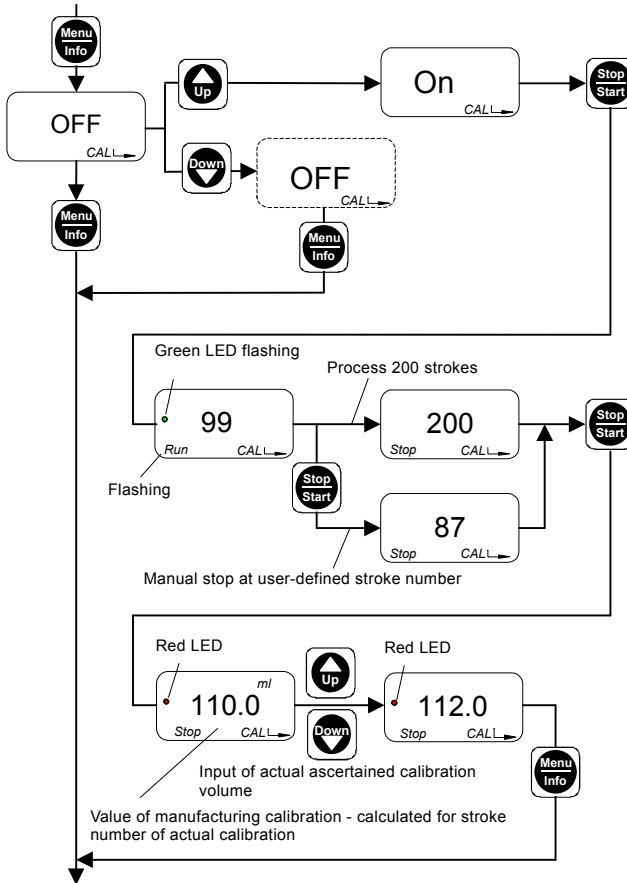

Fig. 44 Calibration

TM03 6618 4506

### 9.6.1 Calibrating pumps with Plus<sup>3</sup> system (internal calibration)

1. Before opening the second menu level, close the isolating valve (D) on the calibration tube (E) and allow the pump to dose a couple of strokes so that the liquid level is within the scale.
2. Stop the pump.
3. Slowly open the isolating valve (D) and allow the dosing medium to rise to the top of the scale in the calibration tube. Close the isolating valve (D).
4. Open the calibration menu.
  - "OFF CAL" appears in the display.
1. Press the "Up" button.
  - "ON CAL" appears in the display.
2. Press the "Start/Stop" button.
  - Calibration is started. The LED flashes green and "Run" flashes in the display.
3. Press the "Start/Stop" button to stop the calibration when the liquid level reaches the bottom of the scale.
  - The LED lights up red.

4. Press the "Start/Stop" button.
  - The current calibration value is displayed (not with replacement circuit boards!).
5. Use the "Up" and "Down" buttons to enter the calibration value (read volume in ml).
 

The pump electronics automatically calculates the calibration value based on the actual strokes performed.
6. Open the isolating valve.
  - Press the "Menu/Info" button (confirm the setting and move on to the next menu item), or
  - press the "Start/Stop" button (confirm the setting and close the second function level).

#### Adjusting the operating counter-pressure without gauging the dosed volume during calibration

If you do not gauge the dosed volume, you can determine the "calibration value" from the following dosing capacity curves in order to adjust your pump to the operating counter-pressure.

#### The curves represent 200 strokes:

- Dosing medium with a viscosity similar to water
- Pumps without Plus<sup>3</sup> system.

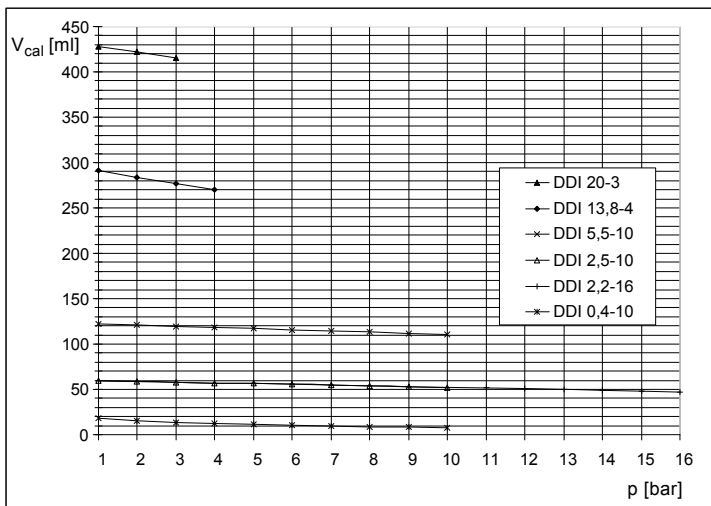

Fig. 45 Dosing capacity curves

**Note** Values are approximate values and do not take into consideration deviations due to construction tolerance according to VDMA 24284.

### 9.6.2 Flow Monitor

In order for the pressure sensor (if installed) to function as a dosing controller, the dosing controller must be switched on, see section 9.10 *Flow Monitor*.

### 9.6.3 Memory function

The memory function is used to store excess contact signals for processing later, see section 9.2.7 *Memory function*.

- Switch the memory function on/off with "Up" / "Down".
- Press the "Menu/Info" button (confirm the setting and move on to the next menu item), or
- press the "Start/Stop" button (confirm the setting and close the second function level).

### 9.6.4 Weighting of current input/output

In current input/output operation, the dosing capacity is controlled via the current signal. The pump emits a current signal as a feedback for control rooms or master/slave applications.

Note

**For weighting of current input/output, see also 9.9 Current signal control 0-20 mA / 4-20 mA.**

### 9.6.5 Batch menu / batch mode

In batch mode, a defined batch quantity is dosed with a defined dosing flow. See section 9.11 *Batch menu / batch mode*.

### 9.6.6 Timer menu / timer mode

In timer mode, a defined batch quantity is dosed with a defined dosing flow and a defined start time. See section 9.12 *Timer menu / timer mode*.

### 9.6.7 PROFIBUS menu

The "PROFIBUS" menu item is only displayed for pumps with PROFIBUS interfaces. The PROFIBUS interface is activated/deactivated in this menu and the bus address is specified.

### 9.6.8 Slow mode

Activating the slow-mode function lengthens (slows down) the suction stroke. For example, cavitation is thus reduced with viscous media. Slow mode can be activated in any operating mode.

Note

**The maximum flow rate of the pump decreases. The time for the suction stroke increases. The maximum stroke rate in slow mode is 120 1/min.**

### 9.6.9 Display/resetting of total dosing capacity

The total capacity dosed since the value was last reset is displayed.

Note

**The maximum value that can be displayed is 9999 l. If this value is exceeded, the counting starts again at zero.**

To reset the value,

1. press the "Up" button.
  - "dEL" appears in the display.
2. Press the "Start/Stop" button.
  - The total dosing capacity is deleted.
- Press the "Menu/Info" button (confirm the setting and move on to the next menu item), or
- press the "Start/Stop" button (confirm the setting and close the second function level).

### 9.6.10 Display of total number of operating hours

The operating hours counter indicates the operating time of the drive, e.g. to check maintenance intervals. The maximum number of operating hours that can be displayed is 99,990 h (display = 9999).

The operating hours counter cannot be reset.

Note

**Multiply the number displayed by 10 to determine the number of operating hours.**

## 9.7 Service level

Open the service level

- to modify the switch assignments of the control unit,
- to set the pump type, or
- to select the unit of measurement for the dosing flow (l/h or gal/h) that will be displayed.

### 9.7.1 Modifying the switch assignment

Note

**You are modifying the default settings of your control unit. They will therefore differ from the technical data.**

The service level can only be accessed when the power supply is switched on.

1. Simultaneously press the "Menu/Info" and "Down" buttons and hold them down.
2. Switch on the power supply.
  - The LED alternately flashes red and green.
3. Release the "Menu/Info" and "Down" buttons.
4. Press the "Start/Stop" button.
5. Press the "Up" button.
  - The LED lights up yellow.
  - "Func" appears in the display.
6. Press the "Menu/Info" button.
  - The service level is opened.

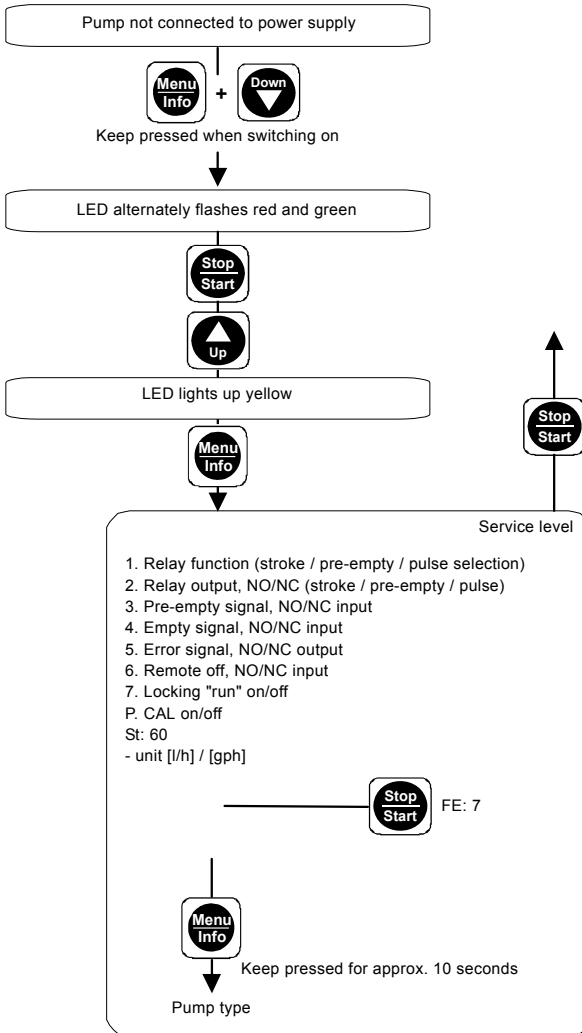

**Fig. 46** Opening / exiting the service level

1. Navigate in the service level by repeatedly pressing the "Menu/Info" button.
2. Use the "Up" and "Down" buttons to modify the switch assignment in the relevant menu.
3. Press the "Menu/Info" button for 10 seconds to open the pump type selection.
4. Press the "Start/Stop" button
  - to confirm the new settings
  - to exit the service level
  - to open the first function level.



### 1. Relay function (stroke / pre-empty / pulse selection)

"1:OFF", "1:ON" or "1:1:1" appears in the display.

- Use the "Up" and "Down" buttons to switch between:
  - "1:OFF": Relay function = stroke signal ("1/min" flashes in the display), and
  - "1:ON": Relay function = pre-empty signal (empty-signal symbol flashes in the display), and
  - "1:1:1": Relay function = pulse input ("n:1" flashes in the display).
- Press the "Menu/Info" button (confirm the setting and move on to the next menu item), or
- press the "Start/Stop" button (confirm the setting and close the service level).

### 2. Relay output, NO/NC (stroke / pre-empty / pulse)

"2:NO" or "2:NC" appears in the display ("1/min" and empty-signal symbol flash in the display).

- Use the "Up" and "Down" buttons to switch between:
  - "2:NO": Stroke/pre-empty signal/pulse input relay = normally open contact, and
  - "2:NC": Stroke/pre-empty signal/pulse input relay = normally closed contact.
- Press the "Menu/Info" button (confirm the setting and move on to the next menu item), or
- press the "Start/Stop" button (confirm the setting and close the service level).

### 3. Pre-empty signal, NO/NC input

"3:NO" or "3:NC" appears in the display (empty-signal symbol flashes in the display).

- Use the "Up" and "Down" buttons to switch between:
  - "3:NO": Pre-empty signal = normally open contact, and
  - "3:NC": Pre-empty signal = normally closed contact.
- Press the "Menu/Info" button (confirm the setting and move on to the next menu item), or
- press the "Start/Stop" button (confirm the setting and close the service level).

### 4. Empty signal, NO/NC input

"4:NO" or "4:NC" appears in the display (empty-signal symbol lights up in the display).

- Use the "Up" and "Down" buttons to switch between:
  - "4:NO": Empty signal = normally open contact, and
  - "4:NC": Empty signal = normally closed contact.
- Press the "Menu/Info" button (confirm the setting and move on to the next menu item), or
- press the "Start/Stop" button (confirm the setting and close the service level).

### 5. Error signal, NO/NC output

"5:NO" or "5:NC" appears in the display ("ERROR" flashes in the display).

- Use the "Up" and "Down" buttons to switch between:
  - "5:NO": Error signal relay = normally open contact, and
  - "5:NC": Error signal relay = normally closed contact.
- Press the "Menu/Info" button (confirm the setting and move on to the next menu item), or
- press the "Start/Stop" button (confirm the setting and close the service level).

### 6. Remote off, NO/NC input

"6:NO" or "6:NC" appears in the display ("Run" and "Stop" flash in the display).

- Use the "Up" and "Down" buttons to switch between:
  - "6:NO": Remote off = normally open contact, and
  - "6:NC": Remote off = normally closed contact.
- Press the "Menu/Info" button (confirm the setting and move on to the next menu item), or
- press the "Start/Stop" button (confirm the setting and close the service level).

### 7. Locking "run" on/off

The locking of the "Start/Stop" button to prevent manual stopping of the pump can be enabled and disabled.

The display indicates "7:ON" or "7:OFF" (the "Run" symbol is displayed).

- Use the "Up" and "Down" buttons to switch between:
  - "7:ON": Locking "run" on, and
  - "7:OFF": Locking "run" off.
- Press the "Menu/Info" button (confirm the setting and move on to the next menu item), or
- press the "Start/Stop" button (confirm the setting and close the service level).

### P: CAL on/off (only for Flow Monitor)

"CAL:ON" or "CAL:OFF" appears in the display ("CAL" appears).

- Use the "Up" and "Down" buttons to switch between:
  - "CAL:ON": Calibration of the pressure sensor for the Flow Monitor enabled, and
  - "CAL:OFF": Calibration of the pressure sensor for the Flow Monitor disabled.

**Note** *For calibration, see section 9.10.7 Calibrating the sensor after the sensor has been replaced.*

### St: e.g. "60" (only for Flow Monitor)

- Use the "Up" and "Down" buttons to set the "number of error strokes permitted when starting". If the number of error strokes is exceeded, the "Flow error" error message appears.

**FE: e.g. "7" (only for Flow Monitor)**

- Use the "Up" and "Down" buttons to set the "number of error strokes permitted during operation". If the number of error strokes is exceeded, the "Flow error" error message appears.

**Selection of unit (display)**

"Unit l/h" or "Unit gph" appears in the display.

- Use the "Up" and "Down" buttons to switch between:
  - "Unit l/h": Unit Q = l/h, and
  - "Unit gph": Unit Q = gal/h.
- Press the "Start/Stop" button (confirm the setting and close the service level), or
- press the "Menu/Info" button for a minimum of 10 seconds (confirm the setting and open the pump selection).

**Pump selection**

**The actual pump type must always be selected to ensure error-free operation of the electronic control function. Otherwise the displayed pump and signals differ from the actual conditions.**

**Caution**

"-0.4", "-2.2", "-2.5", "-5.5", "-13.8" or "-20" appears in the display.

- Use the "Up" and "Down" buttons to switch between the pump types DDI 0.4-10, DDI 2.2-16, DDI 2.5-10, DDI 5.5-10, DDI 13.8 and DDI 20-3.
- Select your pump type, which is indicated on the pump nameplate.
- Press the "Start/Stop" button and switch the power supply off, then back on again (confirm the setting and close the service level).

**9.8 Resetting to default settings**

You can reset the first and second function levels to the default settings while the power supply is being connected.

**The service level settings (pump type, unit of display for the dosing flow, input and output settings) and the values for the total dosing capacity and operating hours counter remain as they are.**

**Note**

The pump is disconnected from the power supply.

- Simultaneously press the "Up" and "Down" buttons and hold them down.
- Switch on the power supply.
  - "boot" appears in the display.
- Release the "Up" and "Down" buttons.
  - All modified settings at the first and second function levels are reset to the default settings.

**9.9 Current signal control**  
**0-20 mA / 4-20 mA**

**For controlling the dosing pump via an external current signal of 0-20 mA (4-20 mA)**

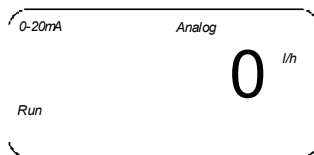

**Fig. 47** Display: 0-20 mA current signal control

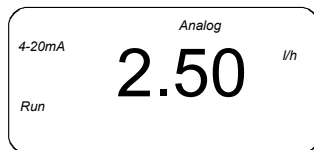

**Fig. 48** Display: 4-20 mA current signal control

- The flow rate is proportional to a current input signal of 0-20 mA (4-20 mA).
- Above 19.5 mA, the pump runs in continuous operation at maximum dosing flow ( $Q_{max}$ ).
- Below 0.2 (4.2) mA, the pump switches off.

**Default setting for  $Q_{max}$  is the dosing flow up to 3 bar (default calibration value). Once the pump has been calibrated, the current signals must be weighted. See sections 9.9.2 With calibrated pump and 9.9.3 Setting the weighting.**

**Note**

**The pump must be started first in this operating mode (LED lights up green and "Run" appears in the display).**

**Note**

- Use the "Start/Stop" button to start or stop the pump.

**4-20 mA current signal control**

If the current input signal falls below 2 mA, the error relay is switched, as an error has probably occurred at the signal source or on the cable.

- The error signal relay switches on. The LED flashes red.
- "4-20 mA" and "ERROR" flash in the display.

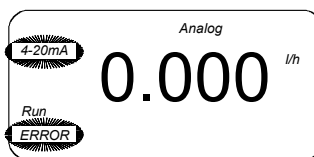
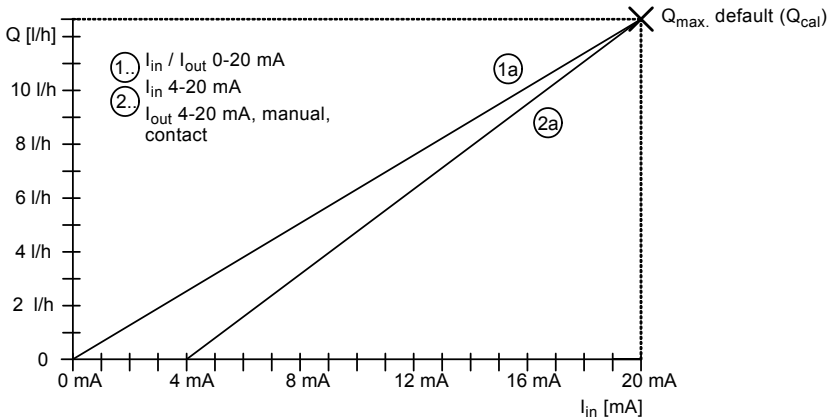

**Fig. 49** Display: 4-20 mA current signal control

**The assignment between the current signal and flow rate is linear.**

- With 0-20 mA current signal control, the curve for current input and current output passes through  $Q = 0$  at 0 mA and the value pair  $Q_{\max.}$  ( $Q_{\text{cal}}$ ) at 20 mA (curve 1a).
- With 4-20 mA current signal control, the curve for current input and current output passes through  $Q = 0$  at 4 mA and the value pair  $Q_{\max.}$  ( $Q_{\text{cal}}$ ) at 20 mA (curve 2a).
- With manual or contact control, the curve for current output passes through  $Q = 0$  at 4 mA and the value pair  $Q_{\max.}$  ( $Q_{\text{cal}}$ ) at 20 mA (curve 2a).

The default setting for  $Q_{\max.}$  is the maximum dosing flow at default calibration at 3 bar.



**Fig. 50** Current input and current output with default setting

### 9.9.1 Direct weighting of the current signal input and output

Weighting while the pump is running can be carried out in the first function level. The currently set value increases or decreases for the maximum flow rate  $Q_{\max.} (Q_{ca})$ , or with weighting set value  $Q_{\text{select mA max.}}$ .

#### Setting the weighting

*The parameters for 0-20 mA and for 4-20 mA are independent of one another. The weighting parameters are modified and saved according to the set operating mode.*

Note

*Select the current control used (0-20 mA / 4-20 mA) before weighting.*

*Weighting can be set independently of the current input value that is currently set. The dosing flow value [l/h] that corresponds to the set current input value [mA] always appears in the display.*

Note

- When the pump is running or stopped, press and hold down the "Up" button for approximately 5 seconds.
  - "0-20 mA" or "4-20 mA", "Analog" and "l/h" flash in the display.
- Use the "Up" and "Down" buttons to increase or decrease the currently set value for the maximum flow rate.

The curve for current input/current output now passes as follows:

- With 0-20 mA (4-20 mA) current signal control, the curve for current input and current output passes linearly through  $Q = 0$  at 0 mA (4 mA) and the currently set value for the maximum flow rate  $Q_{\text{select max.}}$  at 20 mA (curves 1b and 2b).

*The set weighting is saved in the pump. The values are retained, e.g. when the power supply is switched off, and are also active when current weighting is called in the second function level.*

Note

Even for current input/current output assignments that are already weighted in the second function level (see curve 3a), subsequent weighting can be set or weighting can be shifted here. The value for the maximum flow rate  $Q_{\text{select mA max.}}$  at  $i_{\text{max.}}$  is shifted (curve 3b).

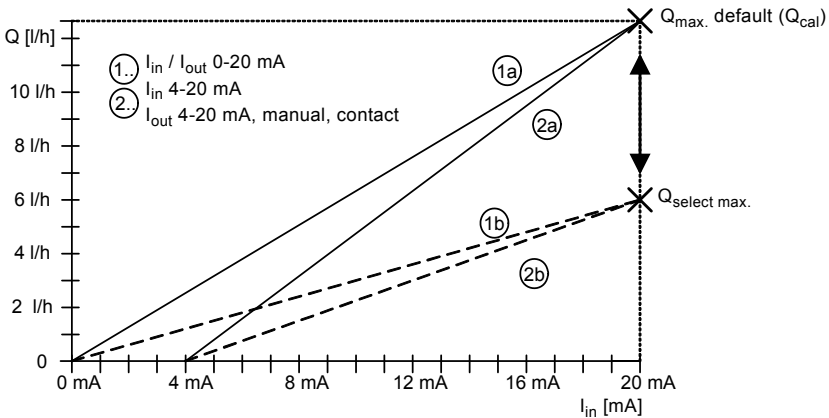
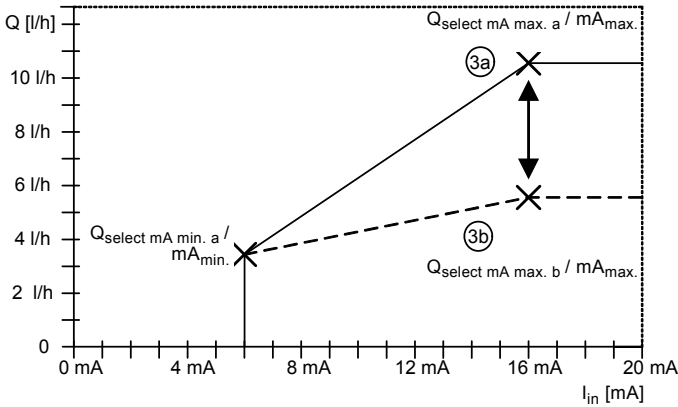

Fig. 51 Current input and current output with direct weighting



TM03 6608 4506

**Fig. 52** Current input and current output with subsequent weighting

### 9.9.2 With calibrated pump

When calibrating the pump for your application and using current signal control and/or current output, proceed as follows:

1. Calibrate the pump.
2. Determine the maximum flow rate  $Q_{cal}$  by taking a reading on the pump:  $Q_{cal}$  is the maximum adjustable flow rate after calibration, e.g. in manual mode, or the displayed flow rate in continuous operation (press and hold down the "Start/Stop" button for longer than 1 second).
3. To set the current input/current output weighting, see section 9.9.3 *Setting the weighting*.

**For unweighted assignment (curves 1a and 2a, see fig. 50) select the following reference points:**

**Note**

**L:**  $mA_{min.} = 0 \text{ (4) mA} / Q_{select \text{ mA min.}} = 0 \text{ l/h}$

**H:**  $mA_{max.} = 20 \text{ mA} / Q_{select \text{ mA max.}} = Q_{cal}$

**$Q_{cal}$  is not updated automatically when the pump is re-calibrated. This protects the user-defined value pairs.**

**Note**

**After calibration, new weighting may be required!**

### 9.9.3 Setting the weighting

**The setting options for weighting depend on the selected current signal control. The parameters for 0-20 mA and for 4-20 mA are independent of one another. The weighting parameters are modified and saved according to the set operating mode.**

**Note**

**Select the current control operating mode used later (0-20 mA / 4-20 mA) manually or via contact signal before weighting. (Weighting of the control output for manual control mode or contact signal control is the same as current weighting 4-20 mA.)**

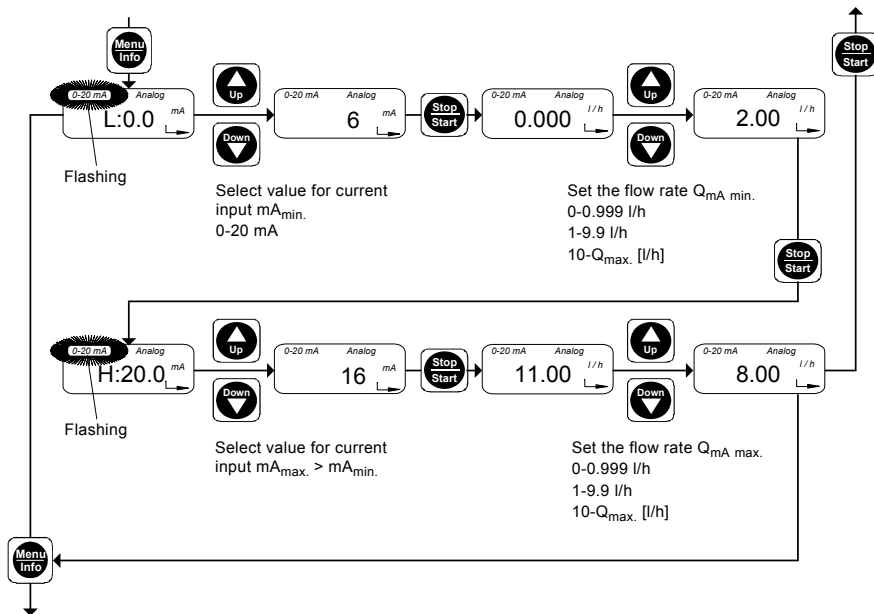

**Fig. 53** Setting the weighting

In the second function level, first enter the values for reference pair L:

The current value for  $mA_{min}$  appears in the display (the default value is "L:0.0 mA" ("L:4.0 mA"), ("Analog" and "0-20 mA" ("4-20 mA) are flashing)).

1. Use the "Up" and "Down" buttons to enter the minimum current input  $mA_{min}$ , between 0 mA (4 mA) and 20 mA (e.g.  $mA_{min}$  = 6 mA).
2. Press the "Start/Stop" button.
  - The current value for the  $mA_{min}$  assigned flow rate  $Q_{mA\ min}$  appears in the display (the default value is 0.000).

3. Use the "Up" and "Down" buttons to enter the desired value for flow rate  $Q_{mA\ min}$  at  $mA_{min}$ . (e.g.  $Q_{mA\ min}$  = 2 l/h).

Now enter the values for reference pair H:

1. Press the "Start/Stop" button.
  - The current value for  $mA_{max}$  appears in the display (the default value is "H:20.0 mA").
2. Use the "Up" and "Down" buttons to enter the maximum current input  $mA_{max}$ .  $> mA_{min}$ . (e.g.  $mA_{max}$  = 16 mA).
3. Press the "Start/Stop" button.
  - The current value for the  $mA_{max}$  assigned flow rate  $Q_{mA\ max}$  appears in the display (the default value is  $Q_{max}$ ).

4. Use the "Up" and "Down" buttons to enter the desired value for flow rate  $Q_{mA\ max}$  at  $mA_{max}$ . (e.g.  $Q_{mA\ max}$  = 8 l/h).

- Press the "Menu/Info" button (confirm the setting and move on to the next menu item), or
- press the "Start/Stop" button (confirm the setting and close the second function level).

### Result of weighting

In the example, the following values were entered as reference points  $L_d$  and  $H_d$ :

$L_d$ :  $mA_{min.} = 6 \text{ mA}$ ,  $Q_{select \text{ mA min.}} = 2 \text{ l/h}$

$H_d$ :  $mA_{max.} = 16 \text{ mA}$ ,  $Q_{select \text{ mA max.}} = 8 \text{ l/h}$ .

The curve for current input/current output now passes through  $Q = 0$  at  $< 6 \text{ mA}$ , from  $Q = 2 \text{ l/h}$  at  $6 \text{ mA}$  to  $Q = 8 \text{ l/h}$  at  $16 \text{ mA}$ , and through  $Q = 8 \text{ l/h}$  at  $> 16 \text{ mA}$  (curve 1d).

In the same way, it is possible to enter a current weighting with a negative gradient. In order to do this, the value pair for reference point L must first be entered with the smaller mA value followed by reference point H.

In the example, the following values were entered as reference points  $L_e$  and  $H_e$ :

$L_e$ :  $mA_{min.} = 2 \text{ mA}$ ,  $Q_{select \text{ mA min.}} = 12 \text{ l/h}$

$H_e$ :  $mA_{max.} = 16 \text{ mA}$ ,  $Q_{select \text{ mA max.}} = 2 \text{ l/h}$ .

The curve for current input/current output now passes through  $Q = 0$  at  $< 2 \text{ mA}$ , from  $Q = 12 \text{ l/h}$  at  $2 \text{ mA}$  to  $Q = 2 \text{ l/h}$  at  $16 \text{ mA}$ , and through  $Q = 2 \text{ l/h}$  at  $> 16 \text{ mA}$  (curve 1e).

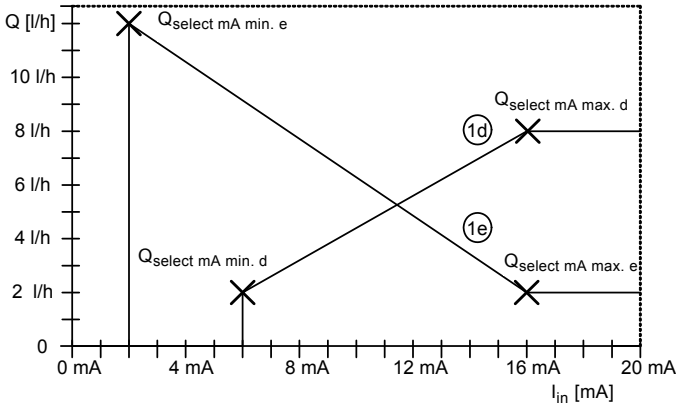

**Fig. 54** Result of weighting

**Note**

**The maximum flow rate of the pump must not be exceeded!**

Note down the set current weighting in the following diagram for current input/current output:

1. Label the Q [l/h] axis for your working area.
2. Mark your reference points with the value pairs:  
L: mA<sub>min.</sub> / Q<sub>select mA min.</sub> and  
H: mA<sub>max.</sub> / Q<sub>select mA max.</sub> in the diagram.
3. Draw the curve as a line from L to H, vertically from Q<sub>select mA min.</sub> to the mA axis, and horizontally from Q<sub>select mA max.</sub> to the edge of the diagram.

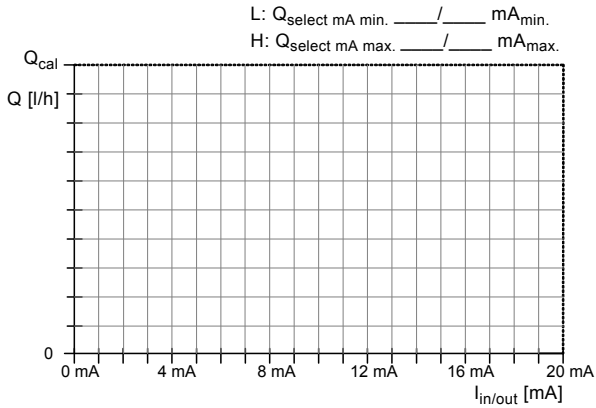

Fig. 55 Diagram for current input/current output



## 9.10 Flow Monitor

### 9.10.1 Application notes

#### Dosing of degassing media (H<sub>2</sub>O<sub>2</sub>, chlorine bleaching agents)

- For a robust operation, set the number of permissible error strokes to a value higher than 10.

#### Dosing of antiscalant (viscosity higher than 20 mPa s), in particular for DDI 0.4-10 with Plus<sup>3</sup>

- Use spring-loaded valves for high-viscosity media.

#### Dosing of viscous media

- For media with a viscosity higher than 20 mPa s, spring-loaded suction and discharge valves are recommended.
- Dosing media with a viscosity higher than 100 mPa s on request.

#### For batch or timer operation

- Set the number of permissible error strokes to a value lower than the number of working strokes.
- If, while the pump is stopped, the pressure in the discharge line falls below the minimum pressure of 2 bar (e.g. in the event of a leak in the pressure-loading valve), increase the number of permissible error strokes so as to prevent unnecessary error messages.

Ensuring the counter-pressure by a pressure-loading valve:

- Check the counter-pressure 2 to 3 weeks after start-up.
  - If it is below 2 bar, the pressure-loading valve has to be re-adjusted.
  - If the volume flow is not constant (as, for example, in the case of contact or analog control), even small volume flows should not fall below the minimum pressure or minimum pressure difference of 2 bar.

#### Set cut-off pressure

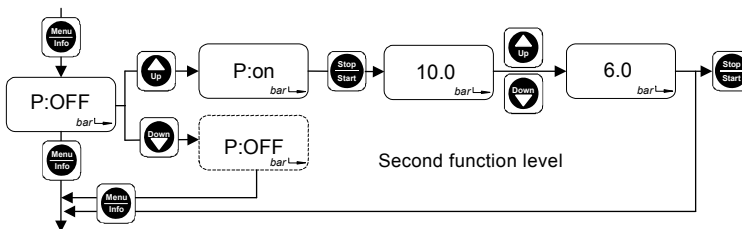

Fig. 56 Set cut-off pressure

### 9.10.2 Setting the Flow Monitor

In order for the pressure sensor (if installed) to function as a dosing controller, the dosing controller must be switched on.

To allow the pump to switch off in the event of overpressure and to set the cut-off pressure of the pump, the pressure control function must be switched on and set.

If no pressure sensor is connected, the pump determines the pressure from the motor current.

**Note** *For applications with high requirements in terms of precision, the pressure control function must be used with a pressure sensor.*

#### Switching on dosing controller

Menu item "flow" is open.

- "flow OFF" appears in the display.
  - Press the "Up" button.
    - "flow ON" appears in the display.
    - The dosing controller is activated.

#### Switching on pressure control function

**Note** *This menu item only appears if the pressure sensor has already been detected once.*

- Press the "Menu/Info" button.
  - Menu item "P" is open.
  - "P:OFF" appears in the display.
- Press the "Up" button.
  - "P:ON" appears in the display.
  - The pressure control function is activated.

"P:ON" in the display:

- Press the "Start/Stop" button.
  - The currently defined cut-off pressure is shown in the display. The default value is the maximum counter-pressure of the pump type + 1 bar (pumps < 10 bar) or + 2 bar (pumps from 10 bar and up).
- Use the "Up" and "Down" buttons to enter the desired cut-off pressure.
  - You can set the cut-off pressure at which the pump is to be stopped at around 2 bar up to the default value.
- Press the "Menu/Info" button (confirm the setting and move on to the next menu item), or
- press the "Start/Stop" button (confirm the setting and close the second function level).

**Note**

*The actual cut-off pressure  $p_{cut-off}$  is higher than the set pressure*  
 $P_{set}; P_{cut-off} = P_{set} + 0.5 \text{ bar.}$

*When you are setting the cut-off pressure, be aware that the pressure measured in the dosing head is higher than the system pressure. It is advisable to display the measured pressure first, see section Displaying the pressure that has been measured. The set cut-off pressure should be higher than the measured pressure in the dosing head.*

**Caution**

### 9.10.3 Dosing controller function

The pump software monitors the dosing process and emits a pulse for each dosing stroke. For each stroke, the "flow" display is momentarily turned off.

- When switched on, the electronics detects whether the dosing controller is activated.
  - "flow" appears in the display.

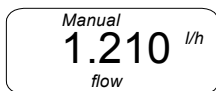

**Fig. 57** Display: "Dosing controller"

### Suppression of dosing control function during start-up operation

60 error strokes\* are permitted during the start-up operation before an error signal is emitted. After a further 7 error strokes\*, a dosing error is signalled.

\* Default values, see also section 9.7.1 *Modifying the switch assignment.*

The start-up operation is triggered as follows:

- By switching on the power voltage.
- Deaeration operation (continuously pressing the "Start/Stop" button).

The start-up operation is completed

- after 60 strokes.
- after the first valid stroke signalled by the dosing controller.
- after short switching on and off the pump by pressing the "Start/Stop" button.

The number of permissible error strokes can be increased or decreased since, depending on pump type for example, 60 strokes may take a considerable time during the start-up operation.

### Dosing error (after start-up operation)

If, after seven successive strokes or after the number of strokes which have been defined by the user, the dosing controller does not emit a signal, this is recognised as an error:

- The error signal relay switches on, but the pump is not switched off.
- The LED flashes red.
- "flow" and "ERROR" flash in the display.

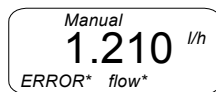

**Fig. 58** Display: "Dosing error"

Once the error has been corrected and seven valid strokes have been measured or the "Start/Stop" button has been pressed, the error signal relay switches off.

- The pump returns to the state it was in before the error occurred.

### 9.10.4 Pressure control function

*To protect the pump and system against excessive pressure build-up, install an overflow valve in the discharge line.*

**Caution**

The pressure sensor monitors the pressure in the dosing head. If the set pressure is exceeded by 0.5 bar, the pump switches off.

When switched on, the electronics detects whether the chamber pressure control function is activated.

- "bar" appears in the display.

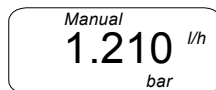

**Fig. 59** Display: "Pressure control"

TM03 6576 4506

TM03 6574 4506

TM03 6577 4506

**Pressure exceeded**

If, after three successive strokes, the cut-off pressure is exceeded, this is recognised as an error:

- The pump is stopped.
- The error signal relay switches on.
- The LED alternately flashes red and green.
- The last pressure value to be measured is displayed.
- "RUN", "ERROR" and "bar" flash in the display.

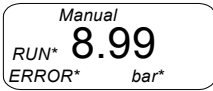

**Fig. 60** Display: "Pressure exceeded"

TM03 6578 4506

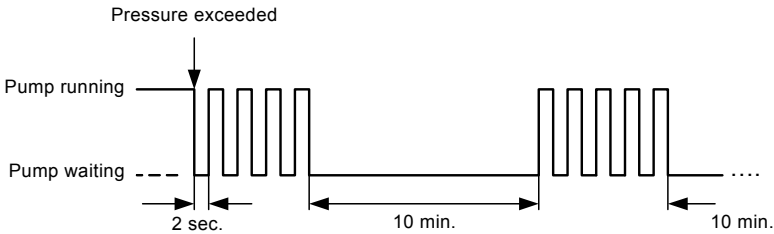

**Fig. 61** Pump restart attempts

TM03 6579 4506

**Error correction**

- Press the "Start/Stop" button to stop the pump and prevent it from restarting.
- Check the discharge valve and the installation on the discharge side and correct any errors, if necessary.  
For maintenance work, see section 10. *Maintenance*.
- Check and correct the pressure setting, if necessary.

**Once the error has been corrected,**

- press the "Start/Stop" button to restart the pump.
  - The pump returns to the state it was in before the error occurred.

**Displaying the pressure that has been measured**

The pressure that has been measured during the pump operation can be displayed at any time.

- Press the "Menu/Info" button twice. (If only pressed once, the dosed quantity is displayed.)
  - The pressure is displayed for approximately 10 seconds.

**Pump restart attempts:**

- First the pump makes four attempts to restart, each separated by a 2-second pause, if the chamber pressure has fallen below the cut-off pressure ( $p_{act} < p_{set}$ ).
- If, after three successive strokes, the cut-off pressure is exceeded, the pump is stopped again.
- After four attempts, the pump waits 10 minutes before attempting to automatically restart again.
- The pump continuously attempts to restart if the chamber pressure decreases in this way.

**9.10.5 Error message – broken cable or faulty sensor**

If the dosing controller and/or the pressure control function are/is switched on, the missing signal is recognised and emitted as an error.

A faulty pressure sensor (broken cable) is displayed as follows:

- The error signal relay switches on.
- The pump is not stopped!
- The LED flashes red.
- "ERROR" flashes in the display.

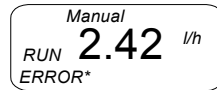

**Fig. 62** Display: "Broken cable"

**Correct error**

- Press the "Start/Stop" button twice to confirm the error and to stop the pump.
- Repair the cable break.

TM03 6580 4506

Once the error has been corrected,

- press the "Start/Stop" button to restart the pump.
  - The pump returns to the state it was in before the error occurred.

**If the cable is broken, the dosing controller and pressure control/pressure display functions are not active. When the "Menu/Info" button is pressed twice to display the chamber pressure, only "— — —" is displayed.**

Note

Note

**If the sensor fault cannot be corrected immediately and if the pump is to continue to run without a sensor, switch off the dosing controller (flow:OFF) and pressure control function (P:OFF).**

### 9.10.6 Changing the number of permissible error strokes

To change the number of permissible error strokes during the start-up operation and during normal dosing operation.

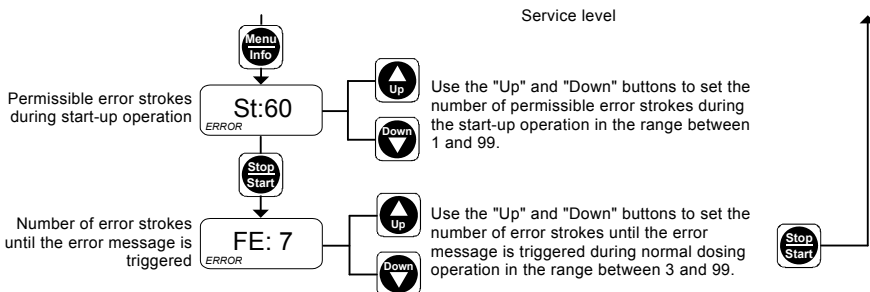

Fig. 63 Permissible error strokes

- Open the service level.
- Repeatedly press the "Menu/Info" button to navigate in the service level until you reach menu item "St:60" (error stroke during start-up operation).
  - The display shows "St" and the number of currently defined error strokes that are permissible during the start-up operation.
- Use the "Up" and "Down" buttons to set the number of permissible error strokes during the start-up operation in the range between 1 and 99.
- Press the "Start/Stop" button.
  - Confirm the setting and go to menu item "FE: 7".
  - The display shows "FE" and the number of currently defined error strokes that are permissible during normal dosing operation.
- Use the "Up" and "Down" buttons to set the number of error strokes until the error message is triggered during normal dosing operation in the range between 3 and 99.
- Press the "Start/Stop" button
  - to confirm the new settings
  - to exit the service level
  - to open the first function level.

### 9.10.7 Calibrating the sensor after the sensor has been replaced

Once a sensor has been replaced, the new sensor must be calibrated to the ambient pressure.

Prepare the pump for the calibration:

- Before screwing in the sensor, check that no dosing liquid is left in the place where the pressure sensor will be screwed in!
- Screw in the new sensor with the correctly fitting O-ring.
- Screw the sensor plug into socket 2.
- Unscrew the suction valve.

## Calibration of sensor

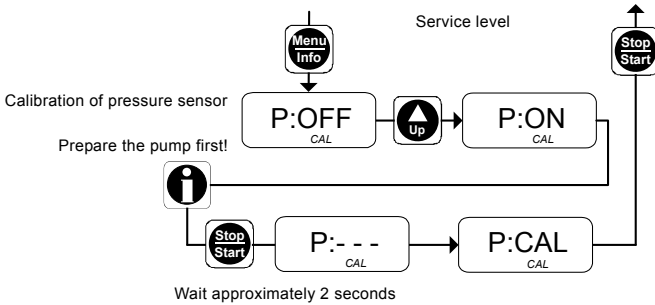

**Fig. 64** Calibration of pressure sensor

1. Open the service level.
2. Repeatedly press the "Menu/Info" button to navigate in the service level until you reach menu item "P" (calibration of pressure sensor).
  - "P:OFF" appears in the display.
3. Press the "Up" button to prepare the calibration.
  - "P:ON" appears in the display.

When the pump is prepared for the calibration, calibrate the pressure sensor:

1. Press the "Start/Stop" button.
  - "P:- - -" is displayed for approximately 2 seconds.
  - "P:CAL" appears in the display.
  - The pressure sensor has been calibrated.
2. Press the "Start/Stop" button
  - to confirm the new settings
  - to exit the service level
  - to open the first function level.
3. Fit the pump back on.
4. Screw in the suction valve.

### Warning

#### **Risk of chemical burns!**



**Wear protective clothing (gloves and goggles) when working on the dosing head, connections or lines!**

**Do not allow any chemicals to leak from the pump. Collect and dispose of all chemicals correctly!**

**The O-rings must be correctly placed in the specified groove.**

### Caution

**Observe the flow direction (indicated by an arrow)!**

**Only tighten the valve by hand.**

## 9.11 Batch menu / batch mode

In batch mode, a defined batch quantity is dosed with a defined dosing flow. The batch can be dosed manually or by an external contact signal.

### *Risk of dosing errors!*

**Batch dosing using contact inputs may be insufficiently or excessively triggered in the event of an error if the pump/system is not monitored. The system must be protected redundantly.**

Caution

### Setting batch dosing

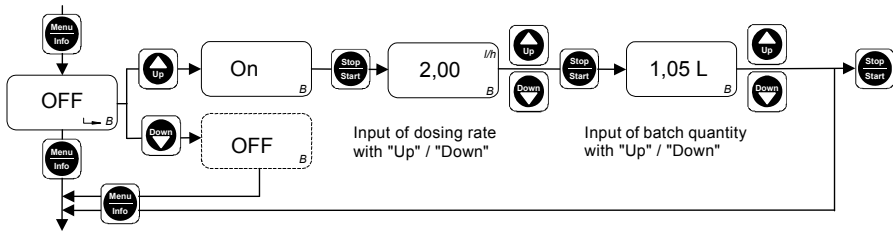

TM03 6615 4506

Fig. 65 Setting batch dosing

In the second function level, "OFF B" appears in the display.

- Press the "Up" button.
  - "ON B" appears in the display.
- Press the "Start/Stop" button.
  - The currently defined flow rate appears in the display.
- Use the "Up" and "Down" buttons to enter the desired flow rate.
- Press the "Start/Stop" button.
  - The currently defined batch quantity appears in the display.
- Use the "Up" and "Down" buttons to enter the desired batch quantity.
  - Press the "Menu/Info" button (confirm the setting and move on to the next menu item), or
  - press the "Start/Stop" button (confirm the setting, close the second function level and enable batch dosing in the first function level).

### Performing batch dosing

- In the first function level, only the batch function is displayed with the "Batch manual" and "Batch contact" menu items.
- "Stop" and the preset batch quantity appear in the display. The LED lights up red.

Use the "Menu/Info" button to select

- "Batch manual", or
- "Batch contact".

Batch mode is controlled at the first and second function levels.

- The batch quantity is set in the second function level.
- The batch function is enabled in the first function level.

Input range for the batch quantity:  
0.0-999.9 ml / 1.00-99.99 l.

### Enabling batch mode

#### Batch manual

Batch dosing is triggered manually.

- Press the "Start/Stop" button.
  - The LED and the "Stop" segment are turned off and "Run" flashes in the display.
  - The preset batch quantity is dosed.

#### Batch contact

Batch dosing is triggered by an external contact signal.

To activate the batch contact function,

- press the "Start/Stop" button.
  - The LED lights up green, the "Stop" segment is turned off and "Run" appears in the display.

When the external contact signal is received, "Run" flashes in the display.

- The preset batch quantity is dosed.

#### During batch dosing

The batch quantity still to be dosed appears in the display.

To display the batch quantity already dosed,

- press the "Down" button.

To display the total batch quantity,

- press the "Up" button.

### Stop/start of pump during batch dosing

To stop the pump,

- press the "Start/Stop" button, or
- actuate remote on/off.

To restart the pump,

- press the "Start/Stop" button.
  - The preset batch cycle continues.
  - For the "Contact" timer, an external contact signal must also be received.

### Deactivating the batch function

1. Open the second function level.
2. Repeatedly press the "Menu/Info" button.
  - "ON B" appears in the display.
3. Press the "Up" button.
  - "OFF B" appears in the display.
  - The batch function is deactivated.

### 9.12 Timer menu / timer mode

In timer mode, a defined batch quantity is dosed with a defined dosing flow. The first dosing starts after the start time  $t_1$  has elapsed. Batch dosing is then repeated after the repetition time  $t_2$  has elapsed until the user stops the process by pressing the "Start/Stop" button or with remote off.

- Input range for the batch quantity: 0.0-999.9 ml / 1.00-99.99 l.
- Input range for the times  $t_1$  and  $t_2$ : 1 min. <  $t_1$  < 999 h / 1 min. <  $t_2$  < 999 h. Input: hh:mm.

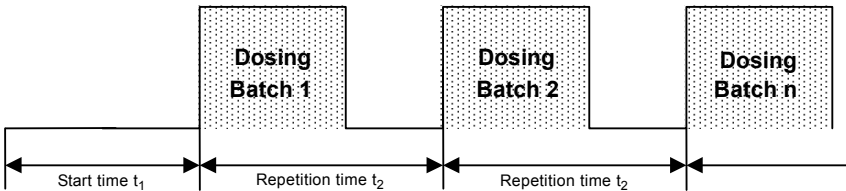

Fig. 66 Timer mode

#### **Risk of dosing errors!**

*If repetition time  $t_2$  is not long enough to dose the batch quantity at the set dosing flow within this time, the pump continues dosing until the current batch quantity is finished. The pump is then stopped and the next batch dosing is triggered after the next repetition time.*

Caution

*Batch dosing in timer mode may be insufficiently or excessively triggered in the event of an error if the pump/system is not monitored. The system must be protected redundantly.*

Timer mode is controlled at the first and second function levels.

- The batch quantity and times  $t_1$  and  $t_2$  are set in the second function level.
- Timer mode is enabled in the first function level.

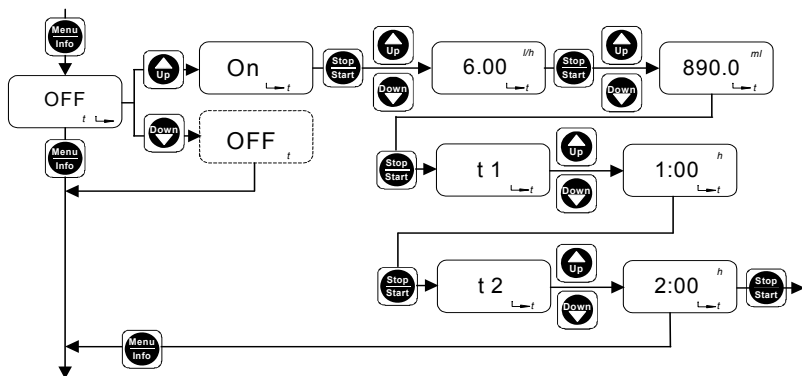

Fig. 67 Setting timer mode

"OFF t" appears in the display.

1. Press the "Up" button.
  - "ON t" appears in the display.
2. Press the "Start/Stop" button.
3. Use the "Up" and "Down" buttons to enter the desired dosing flow.
  - The selected dosing flow appears in the display.
4. Press the "Start/Stop" button.
5. Use the "Up" and "Down" buttons to enter the desired batch quantity.
  - The selected batch quantity appears in the display.
6. Press the "Start/Stop" button.
  - "t1" appears in the display.
  - Use the "Up" and "Down" buttons to enter start time  $t_1$ .
7. Press the "Start/Stop" button.
  - "t2" appears in the display.
8. Use the "Up" and "Down" buttons to enter repetition time  $t_2$ .
  - Press the "Menu/Info" button (confirm the setting and move on to the next menu item), or
  - press the "Start/Stop" button (confirm the setting, close the second function level and enable timer mode in the first function level).

#### Selecting "Manual" or "Contact" timer mode

- When the pump is running (LED lights up green), press the "Start/Stop" button.
  - "Stop" and the preset start time  $t_1$  appear in the display. The LED lights up red.
  - "Manual" or "Contact" appears in the display ("Manual" is default setting).

In the first function level, only the timer function is displayed with the "Timer manual" and "Timer contact" menu items.

- Use the "Menu/Info" button to select
  - "Timer manual", or
  - "Timer contact".

#### Enabling timer mode

##### Timer manual

Batch dosing with the preset pause time is triggered manually.

- Press the "Start/Stop" button.
  - The LED lights up green, the "Stop" segment is turned off and "Run" flashes in the display.
  - The preset batch cycle is started.

##### Timer contact

Batch dosing with the preset pause time is triggered by an external contact signal.

To activate the batch contact function,

- press the "Start/Stop" button.
  - The LED lights up green, the "Stop" segment is turned off and "Run" appears in the display.

When the external contact signal is received, "Run" flashes in the display.

- The preset batch cycle is started.

##### During pause times

The time remaining until the next dosing appears in the display.

To display the time already elapsed,

- press the "Down" button.

To display the total time  $t_1$  or  $t_2$ ,

- press the "Up" button.



### During timer dosing

The batch quantity still to be dosed appears in the display.

To display the batch quantity already dosed,

- press the "Down" button.

To display the total batch quantity,

- press the "Up" button.

### Stop/start of pump during timer dosing

To stop the pump,

- press the "Start/Stop" button, or
- actuate remote on/off.

To restart the pump,

- press the "Start/Stop" button.
  - The preset batch cycle continues.
  - For the "Contact" timer, an external contact signal must also be received.

### Deactivating the timer function

1. Open the second function level.
2. Repeatedly press the "Menu/Info" button.
  - "ON t" appears in the display.
3. Press the "Up" button.
  - "OFF t" appears in the display.
  - The timer function is deactivated.

## 9.13 Creating a master/slave application

You can connect several secondary pumps and control the secondary pumps (slaves) via the first pump (master).

### 9.13.1 Master

**All operating modes are available for the master pump:**

- Manual
- Contact
- Batch dosing with manual/contact start
- Timer mode with manual/contact start
- Current control.

**Select the output signal of the master pump in the service level (relay 1) (output socket 3):**

- Stroke signal (emits one output signal per stroke) must be used for manual or current control of the master pump, or
- pulse input (emits one output signal per contact input signal) must be used for contact control of the master pump.

**Alternatively select the current output (output socket 2) for current control of the slave pump.**

*Please note that the current output can differ from the current input, e.g. when the pump is stopped, and please observe the modified current output values with weighted current control.*

Note

### 9.13.2 Slave

The following operating modes are available for slave pumps in contact or current control (input socket 4):

- Contact
- Batch dosing with contact start
- Timer mode with contact start
- Current control.

*The settings for the operating modes of the slave pumps are implemented independently of settings for the master pump.*

Note

*Unused pulse inputs from the master pump are forwarded to the slave pumps when output signal = pulse input is set. They are processed on the slave pumps according to the slave pump settings!*

Caution

## 9.14 Hotkeys / info keys

The following important displays and functions of the DDI 209 can be accessed quickly using button combinations (hotkeys).

### Service functions

| Function                               | Operating state of the pump                     | Activate function / display   | Deactivate function / display    |
|--|---|---|----------------------------------|
| Deaerate.                              | In "Run", "Stop" or "Menu/Info" mode.           | Press the "Start/Stop" button for at least 1 second.                                  | Release the "Start/Stop" button. |
| Move back the diaphragm for servicing. | The pump must be in "Stop" mode.                | Simultaneously press the "Up" and "Down" buttons.                                     | —                                |
| Boot function.                         | The pump is disconnected from the power supply. | Simultaneously press the "Up" and "Down" buttons while switching on the power supply. | —                                |
| Delete the total dosing capacity.      | In "Run" mode.                                  | Press the "Menu/Info" button for 5 seconds.   | —                                |

### Display functions in batch and timer operation

| Display / function   | Operating state of the pump                          | Activate function / display | Deactivate function / display |
|--|--|-----------------------------|-------------------------------|
| Display the batch quantity already dosed since start of the batch. | During the batch dosing in batch or timer operation. | Press the "Down" button.    | Release the "Down" button.    |
| Display total batch quantity.                                      |  | Press the "Up" button.      | Release the "Up" button.      |
| Display the time that has already elapsed.                         | During pause times in timer operation.               | Press the "Down" button.    | Release the "Down" button.    |
| Display the total time.  |  | Press the "Up" button.      | Release the "Up" button.      |

### Other display functions

| Display / function                 | Operating state of the pump           | Activate function / display   | Deactivate function / display                     |
|------------------------------------|---------------------------------------|-------------------------------|---|
| Display the total dosing capacity. | In "Run" mode.                        | Press the "Menu/Info" button. | Display automatically jumps back after 5 seconds. |
| Display the input current.         | In "Analog" mode (0-20 mA / 4-20 mA). | Press the "Down" button.      |   |

## 10. Maintenance

### 10.1 General notes

#### Warning

When dosing dangerous media, observe the corresponding safety precautions!



#### Risk of chemical burns!

Wear protective clothing (gloves and goggles) when working on the dosing head, connections or lines!

Do not allow any chemicals to leak from the pump. Collect and dispose of all chemicals correctly!

#### Warning

The pump housing must only be opened by personnel authorised by Grundfos!



Repairs must only be carried out by authorised and qualified personnel!

Switch off the pump and disconnect it from the power supply before carrying out maintenance work and repairs!

### 10.2 Maintenance intervals

In the event of a diaphragm leakage, the dosing liquid may leak out of the hole in the intermediate flange between the pump and the dosing head.

The parts inside the housing are protected from the dosing liquid for a short time (depending on the type of liquid) by the housing sealing. It is necessary to check regularly (daily) if liquid is leaking out of the intermediate flange.

#### Caution

For maximum safety, we recommend the pump version with diaphragm leakage detection.

- At least every 12 months or after 4,000 operating hours. When dosing crystallising liquids, more frequently.
- In the event of a fault.

#### 10.2.1 Cleaning the valves and diaphragm

- Clean the diaphragm and valves and replace, if necessary (for stainless-steel valves: inner valve parts).

### 10.3 Cleaning suction and discharge valves

#### Note

If possible, rinse the dosing head, e.g. by supplying it with water.

#### 10.3.1 Switching off the pump

1. Switch off the pump and disconnect it from the power supply.
2. Depressurise the system.
3. Take suitable steps to ensure that the returning dosing medium is safely collected.

#### 10.3.2 Unscrewing the priming chamber valve (Plus<sup>3</sup> system)

When using the Plus<sup>3</sup> system, unscrew the priming chamber valve (3c) as follows:

1. Remove the cover (L) from the priming chamber.
2. Remove the valve tube (R) with the valve (3c).
3. Unscrew the valve (3c) from the valve tube.

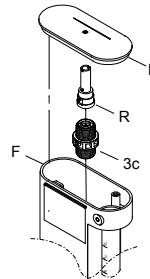

Fig. 68 Priming chamber valve

#### 10.3.3 Unscrewing suction and discharge valves/cleaning valves

1. Unscrew the suction and discharge valves.
2. Dismantle the inner valve parts:
  - Standard DN 4/DN 8 valve:
    - Carefully push out the inner valve part using a thin wire nail (or paper clip) in the flow direction (see arrow on the valve body).
    - Dismantle the inner parts: seat (4r), O-ring (1r), balls (3r), ball cages (2r).

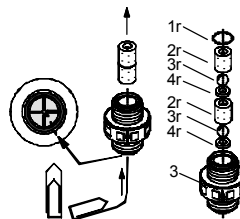
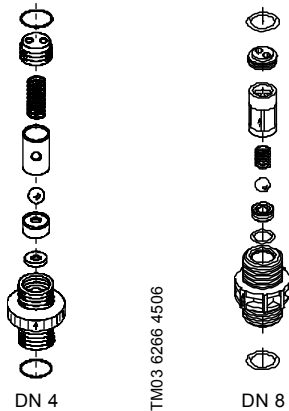

Fig. 69 Standard DN 4/DN 8 valve

TM03 6264 4506

TM03 6265 4506

- Spring-loaded DN 4/DN 8 valve:
  - Unscrew the valve cover.
  - Dismantle the inner parts (as shown in fig. 70).



**Fig. 70** Spring-loaded DN 4 valve / spring-loaded DN 8 valve

### 3. Clean all parts.

If faulty parts are detected, proceed as follows:

- Replace the valve (for stainless-steel valves: inner valve parts).  
For contents and product numbers of the spare parts kits, contact Grundfos.

### 4. Re-assemble and refit the valve.

### 5. Remove the deaeration cartridge (1p, 2p, 3p) under the discharge valve from the dosing head using a pair of tweezers.

- Dismantle the cartridge.
- Clean the cartridge.

If faulty parts are detected, proceed as follows:

- Replace the deaeration cartridge.  
For contents and product numbers of the spare parts kits, contact Grundfos.
- Re-assemble the cartridge.

### 6. Refit all parts.

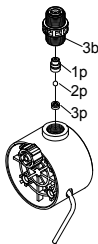

**Fig. 71** Standard DN 4/DN 8 valve

**The O-rings must be correctly placed in the specified groove.**

**Caution**

**Observe the flow direction (indicated by an arrow)!**

**Only tighten the valve by hand.**

## 10.4 Replacing the diaphragm

**Warning**

**Risk of chemical burns!**



**Wear protective clothing (gloves and goggles) when working on the dosing head, connections or lines!**

**Do not allow any chemicals to leak from the pump. Collect and dispose of all chemicals correctly!**

**Note**

**If possible, rinse the dosing head, e.g. by supplying it with water.**

### 10.4.1 Resetting the diaphragm

When replacing the diaphragm, it must be at the back dead point (end of suction stroke). As the stroke usually ends at the front dead point, reset the diaphragm as follows:

- With the pump stopped (LED lights up red), press the "Up" and "Down" buttons simultaneously.
  - The diaphragm is reset.

### 10.4.2 Switching off the pump

1. Switch off the pump and disconnect it from the power supply.
2. Depressurise the system.
3. Take suitable steps to ensure that the returning dosing medium is safely collected.

### 10.4.3 Replacing the diaphragm

See fig. 72 or 73.

1. Loosen the four screws (1q + 2q) on the dosing head (2).
2. Remove the dosing head (2).
3. Unscrew the diaphragm (Q) counter-clockwise.
  - For pumps without Plus<sup>3</sup> system: Replace the sealing diaphragm (3q), intermediate ring (4q) and support disk (5q).
4. Screw in the new diaphragm (Q).
5. Replace the dosing head (2) and cross-tighten the screws (1q + 2q).  
Maximum torque:  
DDI 0.4 - DDI 5.5: 2.1 Nm.  
DDI 13.8 - DDI 20: 2.5 Nm.
6. Vent and start up the dosing pump.

**After initial start-up and after each time the diaphragm is changed, tighten the dosing head screws.**

**After approximately 6-10 operating hours or two days, cross-tighten the dosing head screws using a torque wrench.**

**Caution**

**Maximum torque:  
DDI 0.4 - DDI 5.5: 2.1 Nm.  
DDI 13.8 - DDI 20: 2.5 Nm.**

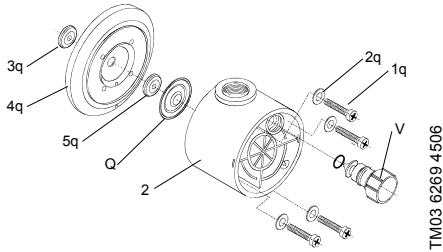

**Fig. 72** Replacing diaphragm without Plus<sup>3</sup> system

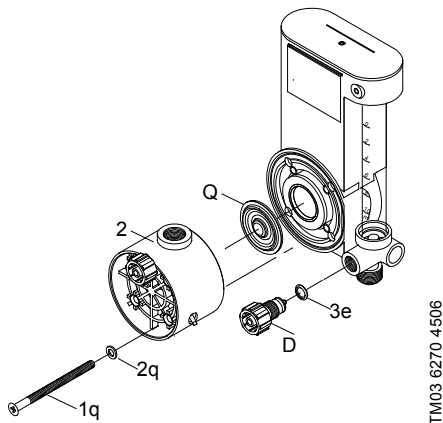

**Fig. 73** Replacing diaphragm with Plus<sup>3</sup> system

## 11. Fault finding chart

| <b>Fault</b>                     | <b>Cause</b>   | <b>Remedy</b>   |
|----------------------------------|--|---|
| 1. Dosing pump does not run.     | a) Not connected to the mains.   | Connect the power supply cable.   |
|                                  | b) Incorrect mains voltage.  | Switch off the pump. Check voltage and motor. If the motor is faulty, return the pump for repair.   |
|                                  | c) Electrical failure.   | Return the pump for repair.   |
| 2. Dosing pump does not suck in. | a) Leaking suction line.   | Replace or seal the suction line.   |
|                                  | b) Cross-section of the suction line too small or suction line too long. | Check with Grundfos specification.  |
|                                  | c) Clogged suction line.   | Rinse or replace the suction line.  |
|                                  | d) Foot valve covered by sediment.                                       | Suspend the suction line from a higher position.  |
|                                  | e) Buckled suction line.   | Install the suction line correctly. Check for damage.   |
|                                  | f) Crystalline deposits in the valves.                                   | Clean the valves.   |
|                                  | g) Diaphragm broken or diaphragm tappet torn out.                        | Replace the diaphragm.  |
|                                  | h) Empty dosing tank.  | Fill the dosing tank.   |
| 3. Dosing pump does not dose.    | a) Air in the suction line and dosing head.                              | Fill the dosing head and suction line.  |
|                                  | b) Viscosity or density of medium too high.                              | Check the installation.   |
|                                  | c) Crystalline deposits in the valves.                                   | Clean the valves.   |
|                                  | d) Valves not correctly assembled.                                       | Assemble the inner valve parts in the right order and check or possibly correct the flow direction. |
|                                  | e) Injection unit blocked.   | Check and possibly correct the flow direction, or remove the obstruction.                           |
|                                  | f) Incorrect installation of lines and peripheral equipment.             | Check the lines for free passage and correct installation.  |
|                                  | g) Empty dosing tank.  | Fill the dosing tank.   |
|                                  | h) Sealing elements not chemically resistant.                            | Replace sealing elements.   |

| <b>Fault</b>   | <b>Cause</b>   | <b>Remedy</b>  |
|--|--|--|
| 4. Dosing flow of the pump is inaccurate.  | a) Dosing head not fully deaerated.  | Repeat the deaeration.   |
|  | b) Degassing medium.   | Check the installation.  |
|  | c) Parts of the valves covered in dirt or incrusted.   | Clean the valves.  |
|  | d) Counter-pressure fluctuations.  | Install a pressure-loading valve and a pulsation damper, if necessary. |
|  | e) Suction lift fluctuations.  | Keep the suction level constant.                                       |
|  | f) Siphon effect (inlet pressure higher than counter-pressure).  | Install a pressure-loading valve.                                      |
|  | g) Leaking or porous suction line or discharge line.   | Replace the suction line or discharge line.                            |
|  | h) Parts in contact with the medium are not resistant to it.   | Replace with resistant materials.                                      |
|  | i) Dosing diaphragm worn (incipient tears).  | Replace the diaphragm. Also observe the maintenance instructions.      |
|  | j) Variation of the dosing medium (density, viscosity).  | Check the concentration. Use an agitator, if necessary.                |
| 5. Loud, piercing noises.  | a) At dosing capacities lower than 10 % of the maximum dosing capacity of the pump, resonance noises may temporarily occur at the stepper motor. | The resonance noise of the stepper motor does not indicate an error.   |
| 6. Liquid leaks out of the hole in the intermediate flange between the pump and the dosing head. | a) A diaphragm leakage has occurred.   | Replace the diaphragm.   |

**Note**

*For further error signals for the control unit, refer to the relevant section.*

## 12. Disposal

This product or parts of it must be disposed of in an environmentally sound way:

1. Use appropriate waste collection services.
2. If this is not possible, contact the nearest Grundfos company or service workshop.

## Safety declaration

Please copy, fill in and sign this sheet and attach it to the pump returned for service.

We hereby declare that this product is free from hazardous chemicals, biological and radioactive substances:

Product type: \_\_\_\_\_

Model number: \_\_\_\_\_

No media or water: \_\_\_\_\_

A chemical solution, name: \_\_\_\_\_

(see pump nameplate)

## Fault description

Please make a circle around the damaged part.

In the case of an electrical or functional fault, please mark the cabinet.



Please give a short description of the fault:

\_\_\_\_\_  
Date and signature

\_\_\_\_\_  
Company stamp





**Argentina**

Bombas GRUNDFOS de Argentina S.A.  
Ruta Panamericana km. 37.500 Lote  
34A  
1619 - Garin  
Pcia. de Buenos Aires  
Phone: +54-3327 414 444  
Telefax: +54-3327 411 111

**Australia**

GRUNDFOS Pumps Pty. Ltd.  
P.O. Box 2040  
Regency Park  
South Australia 5942  
Phone: +61-8-8461-4611  
Telefax: +61-8-8340 0155

**Austria**

GRUNDFOS Pumpen Vertrieb  
Ges.m.b.H.  
Grundfosstraße 2  
A-5082 Grödig/Salzburg  
Tel.: +43-6246-883-0  
Telefax: +43-6246-883-30

**Belgium**

N.V. GRUNDFOS Bellux S.A.  
Boomsesteenweg 81-83  
B-2630 Aartselaar  
Tél.: +32-3-870 7300  
Télécopie: +32-3-870 7301

**Belarus**

Представительство ГРУНДФОС в  
Минске  
220123, Минск,  
ул. В. Хоружей, 22, оф. 1105  
Tel.: +(375) 17 233 97 65  
Факс: (375) 17 233 97 69  
E-mail: grundfos\_minsk@mail.ru

**Bosnia/Herzegovina**

GRUNDFOS Sarajevo  
Trg Heroja 16,  
BiH-71000 Sarajevo  
Phone: +387 33 713 290  
Telefax: +387 33 659 079  
e-mail: grundfos@bih.net.ba

**Brazil**

BOMBAS GRUNDFOS DO BRASIL  
Av. Humberto de Alencar Castelo  
Branco, 630  
CEP 09850 - 300  
São Bernardo do Campo - SP  
Phone: +55-11 4393 5533  
Telefax: +55-11 4343 5015

**Bulgaria**

Grundfos Bulgaria EOOD  
Slatina District  
Iztochna Tangenta street no. 100  
BG - 1592 Sofia  
Tel. +359 2 49 22 200  
Fax. +359 2 49 22 201  
email: bulgaria@grundfos.bg

**Canada**

GRUNDFOS Canada Inc.  
2941 Brighton Road  
Oakville, Ontario  
L6H 6C9  
Phone: +1-905 829 9533  
Telefax: +1-905 829 9512

**China**

**Grundfos Aildos  
Dosing & Disinfection**  
ALLDOS (Shanghai) Water Technology  
Co. Ltd.  
West Unit, 1 Floor, No. 2 Building (T 4-2)  
278 Jinhu Road, Jin Qiao Export Pro-  
cessing Zone  
Pudong New Area  
Shanghai, 201206  
Phone: +86 21 5055 1012  
Telefax: +86 21 5032 0596  
E-mail: grundfosaildos-CN@grund-  
fos.com

**China**

GRUNDFOS Pumps (Shanghai) Co. Ltd.  
50/F Maxdo Centre No. 8 Xing Yi Rd.  
Hongqiao Development Zone  
Shanghai 200336  
PRC  
Phone: +86-21 6122 5222  
Telefax: +86-21 6122 5333

**Croatia**

GRUNDFOS CROATIA d.o.o.  
Cebini 37, Buzin  
HR-10010 Zagreb  
Phone: +385 1 6595 400  
Telefax: +385 1 6595 499  
www.grundfos.hr

**Czech Republic**

GRUNDFOS s.r.o.  
Čapkovského 21  
779 00 Olomouc  
Phone: +420-585-716 111  
Telefax: +420-585-716 299

**Denmark**

GRUNDFOS DK A/S  
Martin Bachs Vej 3  
DK-8850 Bjerringbro  
Tlf.: +45-87 50 50 50  
Telefax: +45-87 50 51 51  
E-mail: info\_GDK@grundfos.com  
www.grundfos.com/DK

**Estonia**

GRUNDFOS Pumps Eesti OÜ  
Peterburi tee 92G  
11415 Tallinn  
Tel: + 372 606 1690  
Fax: + 372 606 1691

**Finland**

OY GRUNDFOS Pumput AB  
Mestarintie 11  
FIN-01730 Vantaa  
Phone: +358-3066 5650  
Telefax: +358-3066 56550

**France**

Pompes GRUNDFOS Distribution S.A.  
Parc d'Activités de Chesnes  
57, rue de Malacombe  
F-38290 St. Quentin Fallavier (Lyon)  
Tél.: +33-4 74 82 15 15  
Télécopie: +33-4 74 94 10 51

**Germany**

GRUNDFOS Water Treatment GmbH  
Reetzstraße 85  
D-76327 Pfingztal (Söllingen)  
Tel.: +49 7240 61-0  
Telefax: +49 7240 61-177  
E-mail: gwt@grundfos.com

**Germany**

GRUNDFOS GMBH  
Schlüterstr. 33  
40699 Erkrath  
Tel.: +49-(0) 211 929 69-0  
Telefax: +49-(0) 211 929 69-3799  
E-mail: infoservice@grundfos.de  
Service in Deutschland:  
E-mail: kundendienst@grundfos.de

**Greece**

GRUNDFOS Hellas A.E.B.E.  
20th km. Athinon-Markopoulou Av.  
P.O. Box 71  
GR-19002 Peania  
Phone: +0030-210-66 83 400  
Telefax: +0030-210-66 46 273

**Hong Kong**

GRUNDFOS Pumps (Hong Kong) Ltd.  
Unit 1, Ground floor  
Siu Wai Industrial Centre  
29-33 Wing Hong Street &  
68 King Lam Street, Cheung Sha Wan  
Kowloon  
Phone: +852-27861706 / 27861741  
Telefax: +852-27858664

**Hungary**

GRUNDFOS Hungária Kft.  
Park u. 8  
H-2045 Törökbálint,  
Phone: +36-23 511 110  
Telefax: +36-23 511 111

**India**

GRUNDFOS Pumps India Private  
Limited  
118 Old Mahabalipuram Road  
Thoraiappakkam  
Chennai 600 097  
Phone: +91-44 4596 6800

**Indonesia**

PT GRUNDFOS Pompa  
Jl. Rawa Sumur III, Blok III / CC-1  
Kawasan Industri, Pulogadung  
Jakarta 13930  
Phone: +62-21-460 6909  
Telefax: +62-21-460 6910 / 460 6901

**Ireland**

GRUNDFOS (Ireland) Ltd.  
Unit A, Merrywell Business Park  
Ballymount Road Lower  
Dublin 12  
Phone: +353-1-4089 800  
Telefax: +353-1-4089 830

**Italy**

GRUNDFOS Pompe Italia S.r.l.  
Via Gran Sasso 4  
I-20060 Truccazzano (Milano)  
Tel.: +39-02-95838112  
Telefax: +39-02-95309290 / 95838461

**Japan**

GRUNDFOS Pumps K.K.  
Gotanda Metalion Bldg. 5F,  
5-21-15, Higashi-gotanda  
Shiagawa-ku, Tokyo,  
141-0022 Japan  
Phone: +81 35 448 1391  
Telefax: +81 35 448 9619

**Korea**

GRUNDFOS Pumps Korea Ltd.  
6th Floor, Aju Building 679-5  
Yeoksam-dong, Kangnam-ku, 135-916  
Seoul, Korea  
Phone: +82-2-5317 600  
Telefax: +82-2-5633 725

**Latvia**

SIA GRUNDFOS Pumps Latvia  
Deglava biznesa centrs  
Augusta Deglava ielā 60, LV-1035, Rīga,  
Tālr.: + 371 714 9640, 7 149 641  
Fakss: + 371 914 9646

**Lithuania**

GRUNDFOS Pumps UAB  
Smolensko g. 6  
LT-03201 Vilnius  
Tel: + 370 52 395 430  
Fax: + 370 52 395 431

**Malaysia**

GRUNDFOS Pumps Sdn. Bhd.  
7 Jalan Peguam U1/25  
Glenmarie Industrial Park  
40150 Shah Alam  
Selangor  
Phone: +60-3-5569 2922  
Telefax: +60-3-5569 2866

**Mexico**

Bombas GRUNDFOS de México S.A. de  
C.V.  
Boulevard TLC No. 15  
Parque Industrial Stiva Aeropuerto  
Apodaca, N.L. 66600  
Phone: +52-81-8144 4000  
Telefax: +52-81-8144 4010

**Netherlands**

GRUNDFOS Netherlands  
Veluwezoom 35  
1326 AE Almere  
Postbus 22015  
1302 CA ALMERE  
Tel.: +31-88-478 6336  
Telefax: +31-88-478 6332  
E-mail: info\_gnl@grundfos.com

**New Zealand**

GRUNDFOS Pumps NZ Ltd.  
17 Beatrice Tinsley Crescent  
North Harbour Industrial Estate  
Albany, Auckland  
Phone: +64-9-415 3240  
Telefax: +64-9-415 3250

**Norway**

GRUNDFOS Pumper A/S  
Strømsveien 344  
Postboks 235, Leirdal  
N-1011 Oslo  
Tlf.: +47-22 90 47 00  
Telefax: +47-22 32 21 50

**Poland**

GRUNDFOS Pompy Sp. z o.o.  
ul. Klonowa 23  
Baranowo k. Poznania  
PL-62-081 Przeźmierowo  
Tel: (+48-61) 650 13 00  
Fax: (+48-61) 650 13 50

**Portugal**

Bombas GRUNDFOS Portugal, S.A.  
Rua Calvet de Magalhães, 241  
Apartado 1079  
P-2770-153 Paço de Arcos  
Tel.: +351-21-440 76 00  
Telefax: +351-21-440 76 90

**Romania**

GRUNDFOS Pompe România SRL  
Bd. Biruintei, nr 103  
Pantelimon county Ilfov  
Phone: +40 21 200 4100  
Telefax: +40 21 200 4101  
E-mail: romania@grundfos.ro

**Russia**

ООО Грундфос  
Россия, 109544 Москва, ул. Школьная  
39  
Тел. (+7) 495 737 30 00, 564 88 00  
Факс (+7) 495 737 75 36, 564 88 11  
E-mail grundfos.moscow@grundfos.com

**Serbia**

GRUNDFOS Predstavništvo Beograd  
Dr. Milutina Ivkovića 2a/29  
YU-11000 Beograd  
Phone: +381 11 26 47 877 / 11 26 47  
496  
Telefax: +381 11 26 48 340

**Singapore**

GRUNDFOS (Singapore) Pte. Ltd.  
24 Tuas West Road  
Jurong Town  
Singapore 638381  
Phone: +65-6865 1222  
Telefax: +65-6861 8402

**Slovenia**

GRUNDFOS d.o.o.  
Šlandrova 8b, SI-1231 Ljubljana-Črnuče  
Phone: +386 1 568 0610  
Telefax: +386 1 568 0619  
E-mail: slovenia@grundfos.si

**South Africa**

Grundfos (PTY) Ltd.  
Corner Mountjoy and George Allen  
Roads  
Wilbart Ext. 2  
Bedfordview 2008  
Phone: (+27) 11 579 4800  
Fax: (+27) 11 455 6066  
E-mail: lsmart@grundfos.com

**Spain**

Bombas GRUNDFOS España S.A.  
Camino de la Fuentequilla, s/n  
E-28110 Algete (Madrid)  
Tel.: +34-91-848 8800  
Telefax: +34-91-628 0465

**Sweden**

GRUNDFOS AB  
(Box 333) Lunnagårdsgatan 6  
431 24 Mölndal  
Tel.: +46 31 332 23 000  
Telefax: +46 31-331 94 60

**Switzerland**

GRUNDFOS ALLDOS International AG  
Schönmattdstraße 4  
CH-4153 Reinach  
Tel.: +41-61-717 5555  
Telefax: +41-61-717 5500  
E-mail: grundfosalldos-CH@grund-  
fos.com

**Switzerland**

GRUNDFOS Pumpen AG  
Bruggacherstrasse 10  
CH-8117 Fällanden/ZH  
Tel.: +41-1-806 8111  
Telefax: +41-1-806 8115

**Taiwan**

GRUNDFOS Pumps (Taiwan) Ltd.  
7 Floor, 219 Min-Chuan Road  
Taichung, Taiwan, R.O.C.  
Phone: +886-4-2305 0868  
Telefax: +886-4-2305 0878

**Thailand**

GRUNDFOS (Thailand) Ltd.  
92 Chaloem Phrakiat Rama 9 Road,  
Dokmai, Pravej, Bangkok 10250  
Phone: +66-2-725 8999  
Telefax: +66-2-725 8998

**Turkey**

GRUNDFOS POMPA San. ve Tic. Ltd.  
Sti.  
Gebze Organize Sanayi Bölgesi  
Ihsan dede Caddesi,  
2. yol 200. Sokak No. 204  
41490 Gebze/ Kocaeli  
Phone: +90 - 262-679 7979  
Telefax: +90 - 262-679 7905  
E-mail: satis@grundfos.com

**Ukraine**

ТОВ ГРУНДФОС УКРАЇНА  
01010 Київ, Вул. Московська 86,  
Тел.: (+38 044) 390 40 50  
Факс.: (+38 044) 390 40 59  
E-mail: ukraine@grundfos.com

**United Arab Emirates**

GRUNDFOS Gulf Distribution  
P.O. Box 16768  
Jebel Ali Free Zone  
Dubai  
Phone: +971-4- 8815 136  
Telefax: +971-4-8815 136

**United Kingdom**

GRUNDFOS Pumps Ltd.  
Grovebury Road  
Leighton Buzzard/Beds. LU7 8TL  
Phone: +44-1525-850000  
Telefax: +44-1525-850011

**U.S.A.**

GRUNDFOS Pumps Corporation  
17100 West 118th Terrace  
Olathe, Kansas 66061  
Phone: +1-913-227-3400  
Telefax: +1-913-227-3500

**Uzbekistan**

Представительство ГРУНДФОС в  
Ташкенте  
700000 Ташкент ул.Усмана Носира 1-й  
тулик 5  
Телефон: (3712) 55-68-15  
Факс: (3712) 53-36-35

Addresses revised 27.04.2012

|                      |
|----------------------|
| <b>91834768</b> 0812 |
|----------------------|

|              |
|--------------|
| ECM: 1062500 |
|--------------|

The name Grundfos, the Grundfos logo, and the payoff Be-Think-Innovate are registered trademarks owned by Grundfos Management A/S or Grundfos A/S, Denmark. All rights reserved worldwide.

---