

TPE, TPED, NKE, NKGE, NBE, NBGE, MTBE

Installation and operating instructions



Installation and operating instructions



TPE, TPED, NKE, NKGE, NBE, NBGE, MTBE

<http://net.grundfos.com/qr/i/96782376>

be
think
innovate

GRUNDFOS 

TPE, TPED, NKE, NKGE, NBE, NBGE, MTBE

English (GB)	
Installation and operating instructions	4
Български (BG)	
Упътване за монтаж и експлоатация	32
Čeština (CZ)	
Montážní a provozní návod	60
Deutsch (DE)	
Montage- und Betriebsanleitung	88
Dansk (DK)	
Monterings- og driftsinstruktion	116
Eesti (EE)	
Paigaldus- ja kasutusjuhend	144
Español (ES)	
Instrucciones de instalación y funcionamiento	172
Suomi (FI)	
Asennus- ja käyttöohjeet	200
Français (FR)	
Notice d'installation et de fonctionnement	228
Ελληνικά (GR)	
Οδηγίες εγκατάστασης και λειτουργίας	256
Hrvatski (HR)	
Montažne i pogonske upute	285
Magyar (HU)	
Telepítési és üzemeltetési utasítás	313
Italiano (IT)	
Istruzioni di installazione e funzionamento	341
Lietuviškai (LT)	
Įrengimo ir naudojimo instrukcija	369
Latviešu (LV)	
Uzstādīšanas un ekspluatācijas instrukcija	397
Nederlands (NL)	
Installatie- en bedieningsinstructies	425
Polski (PL)	
Instrukcja montażu i eksploatacji	453
Português (PT)	
Instruções de instalação e funcionamento	481
Română (RO)	
Instrucţiuni de instalare şi utilizare	509
Srpski (RS)	
Uputstvo za instalaciju i rad	537
Svenska (SE)	
Monterings- och driftsinstruktion	565
Slovensko (SI)	
Navodila za montažo in obratovanje	593
Slovenčina (SK)	
Návod na montáž a prevádzku	621
Türkçe (TR)	
Montaj ve kullanım kılavuzu	649

TPE, TPED, NKE, NKGE, NBE, NBGE, MTBE

Українська (UA)	
Інструкції з монтажу та експлуатації	677
Bahasa Indonesia (ID)	
Petunjuk pengoperasian dan pemasangan	705
Македонски (MK)	
Упатства за монтирање и ракување	733
Shqip (SQ)	
Udhëzimet e instalimit dhe funksionimit	761
(AR) العربية	
تعليمات التركيب و التشغيل	817
Appendix	818

CONTENTS

	Page
1. Symbols used in this document	4
2. General information	4
3. General description	4
3.1 Settings	4
3.2 Twin-head pumps	4
4. Mechanical installation	5
4.1 Motor cooling	5
4.2 Outdoor installation	5
5. Electrical connection	5
5.1 Cable requirements	5
5.2 Electrical connection - single-phase pumps	5
5.3 Electrical connection - three-phase pumps up to 7.5 kW	7
5.4 Electrical connection - three-phase pumps, 11-22 kW	9
5.5 Signal cables	12
5.6 Bus connection cable	12
5.7 Communication cable for TPED pumps	12
6. Modes	13
6.1 Overview of modes	13
6.2 Operating mode	13
6.3 Control mode	14
6.4 Factory setting	14
7. Setting by means of control panel	14
7.1 Setpoint setting	15
7.2 Setting to max. curve duty	15
7.3 Setting to min. curve duty	15
7.4 Start/stop of pump	15
8. Setting by means of R100	15
8.1 Menu OPERATION	17
8.2 Menu STATUS	18
8.3 Menu INSTALLATION	19
9. Setting by means of PC Tool E-products	22
10. Priority of settings	22
11. External forced-control signals	23
11.1 Start/stop input	23
11.2 Digital input	23
12. External setpoint signal	23
13. Bus signal	24
14. Other bus standards	24
15. Indicator lights and signal relay	24
16. Insulation resistance	25
17. Emergency operation (only 11-22 kW)	26
18. Maintenance and service	27
18.1 Cleaning of the motor	27
18.2 Relubrication of motor bearings	27
18.3 Replacement of motor bearings	27
18.4 Replacement of varistor (only 11-22 kW)	27
18.5 Service parts and service kits	27
19. Technical data - single-phase pumps	27
19.1 Supply voltage	27
19.2 Overload protection	27
19.3 Leakage current	27
19.4 Inputs/outputs	27
20. Technical data - three-phase pumps up to 7.5 kW	28
20.1 Supply voltage	28
20.2 Overload protection	28
20.3 Leakage current	28
20.4 Inputs/output	28
21. Technical data - three-phase pumps, 11-22 kW	28
21.1 Supply voltage	28
21.2 Overload protection	28
21.3 Leakage current	28
21.4 Inputs/output	29

22. Other technical data	29
23. Disposal	31

**Warning**

Prior to installation, read these installation and operating instructions. Installation and operation must comply with local regulations and accepted codes of good practice.

1. Symbols used in this document**Warning**

If these safety instructions are not observed, it may result in personal injury!

**Warning**

The surface of the product may be so hot that it may cause burns or personal injury.

**Caution**

If these safety instructions are not observed, it may result in malfunction or damage to the equipment.

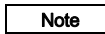
**Note**

Notes or instructions that make the job easier and ensure safe operation.

2. General information

These installation and operating instructions are a supplement to installation and operating instructions for the corresponding standard pumps TP, TPD, NK, NKG and NB, NBG, MTB. For instructions not mentioned specifically here, please see installation and operating instructions for the standard pump.

3. General description

Grundfos E-pumps have standard motors with integrated frequency converter. The pumps are for single-phase or three-phase mains connection.

The pumps have a built-in PI controller and can be set up for an external sensor enabling control of the following parameters:

- pressure
- differential pressure
- temperature
- differential temperature
- flow.

From factory, the pumps have been set to control mode uncontrolled. The PI controller can be activated by means of R100.

The pumps are typically used as circulator pumps in large heating or cooling water systems with variable demands.

3.1 Settings

The desired setpoint, can be set in three different ways:

- directly on the pump control panel
- via an input for external setpoint signal
- by means of the Grundfos wireless remote control R100.

All other settings are made by means of the R100.

Important parameters such as actual value of control parameter, power consumption, etc. can be read via the R100.

3.2 Twin-head pumps

Twin-head pumps do not require any external controller.

4. Mechanical installation

Note

In order to retain the UL/cURus approval, follow the additional installation procedures on page 818.

4.1 Motor cooling

To ensure sufficient cooling of motor and electronics, observe the following requirements:

- Make sure that sufficient cooling air is available.
- Keep the temperature of the cooling air below 40 °C.
- Keep cooling fins and fan blades clean.

4.2 Outdoor installation

When installed outdoors, the pump must be provided with a suitable cover to avoid condensation on the electronic components. See fig. 1.

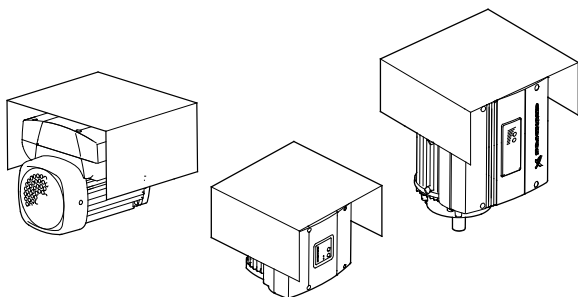

Fig. 1 Examples of covers

Remove the drain plug pointing downwards in order to avoid moisture and water build-up inside the motor.

Vertically mounted pumps are IP55 after removal of the drain plug. Horizontally mounted pumps change enclosure class to IP54.

5. Electrical connection

For description of how to connect E-pumps electrically, see the following pages:

[5.2 Electrical connection - single-phase pumps](#), page 5

[5.3 Electrical connection - three-phase pumps up to 7.5 kW](#), page 7

[5.4 Electrical connection - three-phase pumps, 11-22 kW](#), page 9.

5.1 Cable requirements

5.1.1 Cable size

Single-phase supply

1.5 mm² / 12-14 AWG.

Three-phase supply

6-10 mm² / 10-8 AWG.

5.1.2 Conductors

Type

Stranded copper conductors only.

Temperature rating

Temperature rating for conductor insulation: 60 °C (140 °F).

Temperature rating for outer cable sheath: 75 °C (167 °F).

5.2 Electrical connection - single-phase pumps



Warning

The user or the installer is responsible for the installation of correct earthing and protection according to local regulations. All operations must be carried out by qualified staff.



Warning

Never make any connections in the pump terminal box unless all electric supply circuits have been switched off for at least 5 minutes.

Note for instance that the signal relay may be connected to an external supply which is still connected when the mains supply is disconnected.

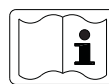

The above warning is indicated on the motor terminal box by this yellow label.



Warning

The surface of the terminal box may be above 70 °C when the pump is operating.

5.2.1 Preparation

Before connecting the E-pump to the mains, take the issues illustrated in the figure below into consideration.

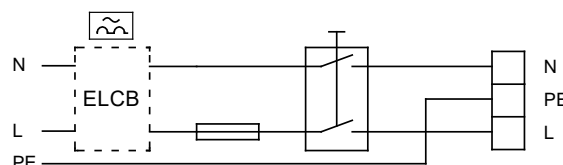

Fig. 2 Mains-connected pump with mains switch, backup fuse, additional protection and protective earthing

5.2.2 Protection against electric shock - indirect contact



Warning

The pump must be earthed and protected against indirect contact in accordance with local regulations.

Protective earth conductors must always have a yellow/green (PE) or yellow/green/blue (PEN) colour marking.

5.2.3 Backup fuses

For recommended fuse sizes, see section [19.1 Supply voltage](#).

5.2.4 Additional protection

If the pump is connected to an electric installation where an earth leakage circuit breaker (ELCB) is used as additional protection, the circuit breaker must be of a type marked with the following symbol:



ELCB

The total leakage current of all the electrical equipment in the installation must be taken into account.

The leakage current of the motor in normal operation can be seen in section [19.3 Leakage current](#).

During start and at asymmetrical supply systems, the leakage current can be higher than normal and may cause the ELCB to trip.

5.2.5 Motor protection

The pump requires no external motor protection. The motor incorporates thermal protection against slow overloading and blocking (IEC 34-11, TP 211).

5.2.6 Protection against mains voltage transients

The pump is protected against voltage transients by built-in varistors between phase-neutral and phase-earth.

5.2.7 Supply voltage and mains

1 x 200-240 V - 10 %/+ 10 %, 50/60 Hz, PE.

The supply voltage and frequency are marked on the pump nameplate. Make sure that the motor is suitable for the power supply of the installation site.

The wires in the terminal box must be as short as possible. Excepted from this is the protective earth conductor which must be so long that it is the last one to be disconnected in case the cable is inadvertently pulled out of the cable entry.

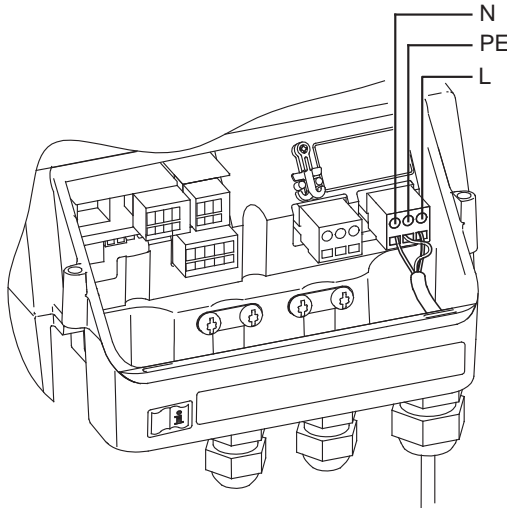

Fig. 3 Mains connection

Cable glands

Cable glands comply with EN 50626.

- 2 x M16 cable gland, cable diameter Ø4-Ø10
- 1 x M20 cable gland, cable diameter Ø10-Ø14
- 1 knock-out cable entry for M16 cable gland.



Warning
If the supply cable is damaged, it must be replaced by qualified staff.

Grid types

Single-phase E-pumps can be connected to all grid types.



Warning
Do not connect single-phase E-pumps to a mains supply with a voltage between phase and earth of more than 250 V.

5.2.8 Start/stop of pump

Caution The number of starts and stops via the mains voltage must not exceed 4 times per hour.

When the pump is switched on via the mains, it will start after approx. 5 seconds.

If a higher number of starts and stops is desired, use the input for external start/stop when starting/stopping the pump.

When the pump is switched on via an external on/off switch, it will start immediately.

5.2.9 Connections

Note If no external on/off switch is connected, connect terminals 2 and 3 using a short wire.

As a precaution, the wires to be connected to the following connection groups must be separated from each other by reinforced insulation in their entire lengths:

Group 1: Inputs

- start/stop, terminals 2 and 3
- digital input, terminals 1 and 9
- setpoint input, terminals 4, 5 and 6
- sensor input, terminals 7 and 8
- GENIbus, terminals B, Y and A

All inputs (group 1) are internally separated from the mains-conducting parts by reinforced insulation and galvanically separated from other circuits.

All control terminals are supplied with protective extra-low voltage (PELV), thus ensuring protection against electric shock.

Group 2: Output (relay signal, terminals NC, C, NO)

The output (group 2) is galvanically separated from other circuits. Therefore, the supply voltage or protective extra-low voltage can be connected to the output as desired.

Group 3: Mains supply (terminals N, PE, L)

Group 4: Communication cable (8-pin male socket) - **only TPED**

The communication cable is connected to the socket in group 4. The cable ensures communication between the two pumps, whether one or two pressure sensors are connected. See section [5.7 Communication cable for TPED pumps](#).

The selector switch in group 4 enables changeover between the operating modes "alternating operation" and "standby operation". See description in section [6.2.1 Additional operating modes - TPED pumps](#).

TM02 0827 2107

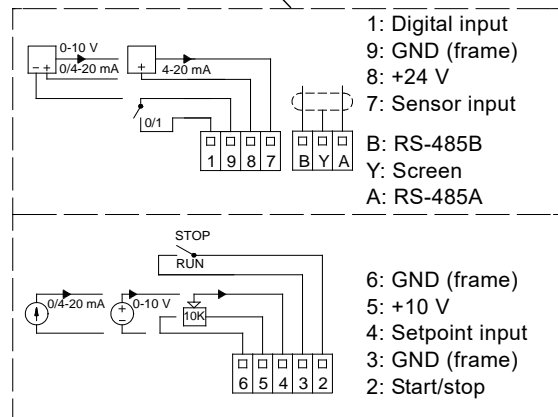
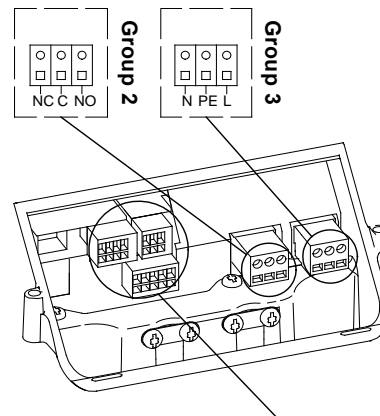

TM02 0795 0904

Fig. 4 Connection terminals - TPE, NKE, NKGE and NBE, NBGE, MTBE

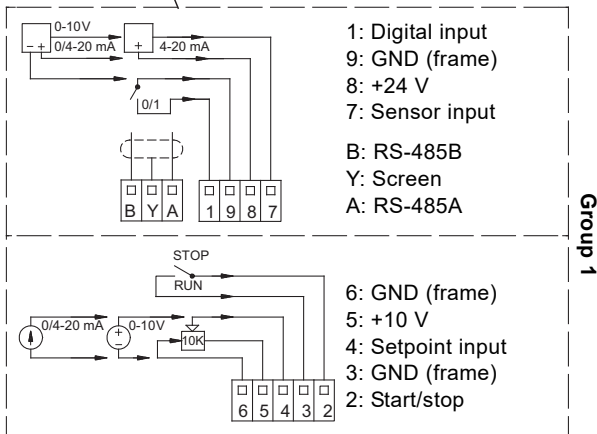
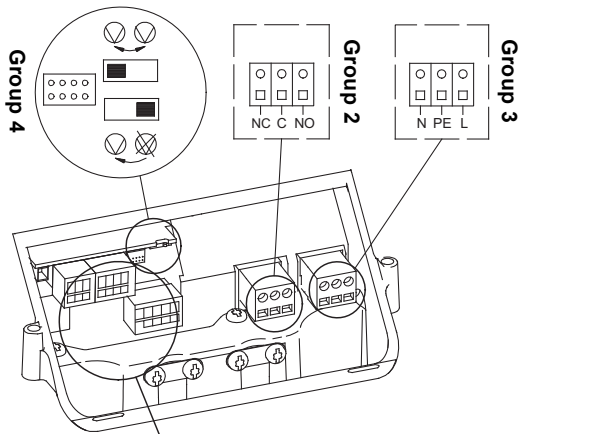

Fig. 5 Connection terminals - TPED

A galvanic separation must fulfil the requirements for reinforced insulation including creepage distances and clearances specified in EN 60335.

5.3 Electrical connection - three-phase pumps up to 7.5 kW



Warning

The user or the installer is responsible for the installation of correct earthing and protection according to local regulations. All operations must be carried out by qualified staff.



Warning

Never make any connections in the pump terminal box unless all electric supply circuits have been switched off for at least 5 minutes.

Note for instance that the signal relay may be connected to an external supply which is still connected when the mains supply is disconnected.

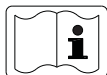

The above warning is indicated on the motor terminal box by this yellow label.

5.3.1 Preparation

Before connecting the E-pump to the mains, take the issues illustrated in the figure below into consideration.

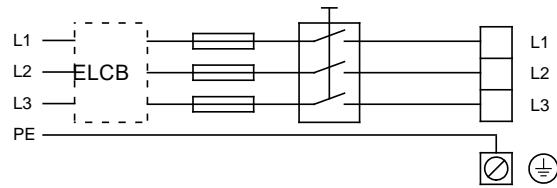

Fig. 6 Mains-connected pump with mains switch, backup fuses, additional protection and protective earthing

5.3.2 Protection against electric shock - indirect contact



Warning

The pump must be earthed in accordance with local regulations.

As the leakage current of 4 - 7.5 kW motors is greater than 3.5 mA, take extra precautions when earthing these motors.

EN 50178 and BS 7671 specify the following precautions when leakage current greater than 3.5 mA:

- The pump must be stationary and installed permanently.
- The pump must be permanently connected to the power supply.
- The earth connection must be carried out as duplicate conductors.

Protective earth conductors must always have a yellow/green (PE) or yellow/green/blue (PEN) colour marking.

5.3.3 Backup fuses

For recommended fuse sizes, see section 20.1 Supply voltage.

5.3.4 Additional protection

If the pump is connected to an electric installation where an earth leakage circuit breaker (ELCB) is used as additional protection, the circuit breaker must be of a type marked with the following symbols:

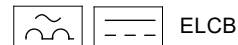

This circuit breaker is type B.

The total leakage current of all the electrical equipment in the installation must be taken into account.

The leakage current of the motor in normal operation can be seen in section 20.3 Leakage current.

During start and at asymmetrical supply systems, the leakage current can be higher than normal and may cause the ELCB to trip.

TM00 9270 4696

TM02 6009 0703

5.3.5 Motor protection

The pump requires no external motor protection. The motor incorporates thermal protection against slow overloading and blocking (IEC 34-11, TP 211).

5.3.6 Protection against mains voltage transients

The pump is protected against voltage transients by built-in varistors between the phases and between phases and earth.

5.3.7 Supply voltage and mains

3 x 380-480 V - 10 %/+ 10 %, 50/60 Hz, PE.

The supply voltage and frequency are marked on the pump nameplate. Make sure that the pump is suitable for the power supply of the installation site.

The wires in the terminal box must be as short as possible. Excepted from this is the protective earth conductor which must be so long that it is the last one to be disconnected in case the cable is inadvertently pulled out of the cable entry.

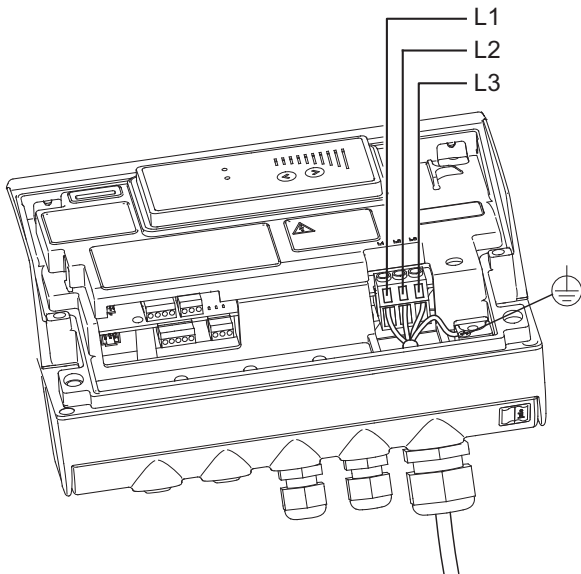

Fig. 7 Mains connection

Cable glands

Cable glands comply with EN 50626.

- 2 x M16 cable gland, cable diameter $\varnothing 4\text{-}\varnothing 10$
- 1 x M20 cable gland, cable diameter $\varnothing 9\text{-}\varnothing 17$
- 2 x M16 knock-out cable entries.



Warning

If the supply cable is damaged, it must be replaced by qualified staff.

Grid types

Three-phase E-pumps can be connected to all grid types.



Warning

Do not connect three-phase E-pumps to a mains supply with a voltage between phase and earth of more than 440 V.

5.3.8 Start/stop of pump

Caution The number of starts and stops via the mains voltage must not exceed 4 times per hour.

When the pump is switched on via the mains, it will start after approx. 5 seconds.

If a higher number of starts and stops is desired, use the input for external start/stop when starting/stopping the pump.

When the pump is switched on via an external on/off switch, it will start immediately.

Automatic restart

Note If a pump set up for automatic restart is stopped due to a fault, it will restart automatically when the fault has disappeared.

However, automatic restart only applies to fault types set up to automatic restart. These faults could typically be one of these faults:

- temporary overload
- fault in the power supply.

5.3.9 Connections

Note If no external on/off switch is connected, connect terminals 2 and 3 using a short wire.

As a precaution, the wires to be connected to the following connection groups must be separated from each other by reinforced insulation in their entire lengths:

Group 1: Inputs

- start/stop, terminals 2 and 3
- digital input, terminals 1 and 9
- setpoint input, terminals 4, 5 and 6
- sensor input, terminals 7 and 8
- GENibus, terminals B, Y and A

All inputs (group 1) are internally separated from the mains-conducting parts by reinforced insulation and galvanically separated from other circuits.

All control terminals are supplied with protective extra-low voltage (PELV), thus ensuring protection against electric shock.

Group 2: Output (relay signal, terminals NC, C, NO)

The output (group 2) is galvanically separated from other circuits. Therefore, the supply voltage or protective extra-low voltage can be connected to the output as desired.

Group 3: Mains supply (terminals L1, L2, L3)

Group 4: Communication cable (8-pin male socket) - **only TPED**

The communication cable is connected to the socket in group 4.

The cable ensures communication between the two pumps, whether one or two pressure sensors are connected. See section [5.7 Communication cable for TPED pumps](#).

The selector switch in group 4 enables changeover between the operating modes "alternating operation" and "standby operation". See description in section [6.2.1 Additional operating modes - TPED pumps](#).

TM03 8600 2007

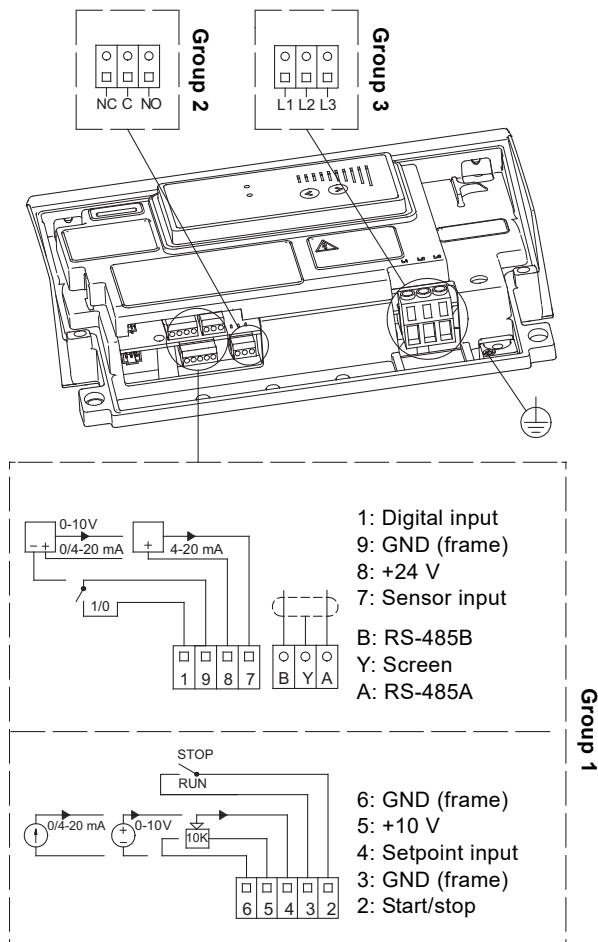

Fig. 8 Connection terminals - TPE, NKE, NKGE and NBE, NBGE, MTBE

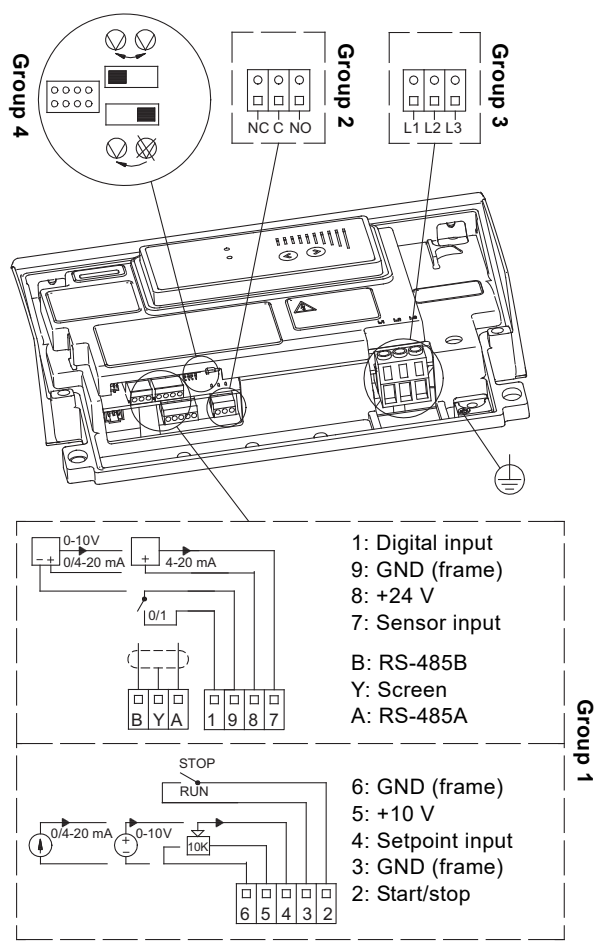





Fig. 9 Connection terminals - TPED

A galvanic separation must fulfil the requirements for reinforced insulation including creepage distances and clearances specified in EN 60335.

5.4 Electrical connection - three-phase pumps, 11-22 kW

- 

Warning
The user or the installer is responsible for the installation of correct earthing and protection according to and local regulations. All operations must be carried out by qualified staff.
- 

Warning
Never make any connections in the pump terminal box unless all electric supply circuits have been switched off for at least 5 minutes.
Note for instance that the signal relay may be connected to an external supply which is still connected when the mains supply is disconnected.
- 

Warning
The surface of the terminal box may be above 70 °C when the pump is operating.

5.4.1 Preparation

Before connecting the E-pump to the mains, take the issues illustrated in the figure below into consideration.

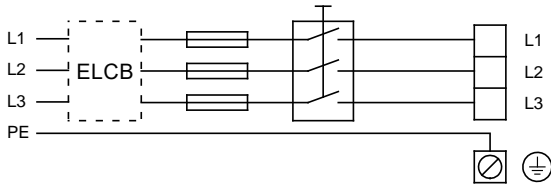

Fig. 10 Mains-connected pump with mains switch, backup fuses, additional protection and protective earthing

5.4.2 Protection against electric shock - indirect contact



Warning

The pump must be earthed in accordance with local regulations.

As the leakage current of 11-22 kW motors is greater than 10 mA, take extra precautions when earthing these motors.

EN 61800-5-1 specifies that the pump must be stationary and installed permanently when the leakage current is greater than 10 mA.

One of the following requirements must be fulfilled:

- A single protective earth conductor having a cross-sectional area of min. 10 mm² copper.

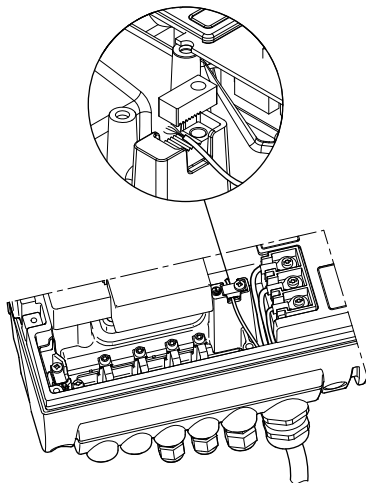

Fig. 11 Connection of a single protective earth conductor using one of the conductors of a 4-core mains cable (with cross-sectional area of min. 10 mm²)

- Two protective earth conductors of the same cross-sectional area as the mains conductors, with one conductor connected to an additional earth terminal in the terminal box.

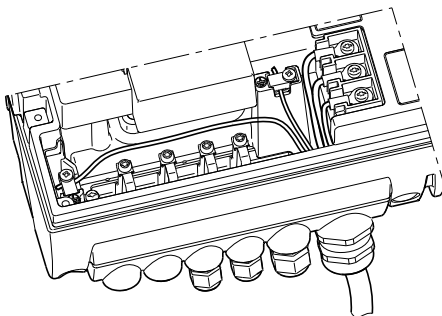

Fig. 12 Connection of two protective earth conductors using two of the conductors of a 5-core mains cable

Protective earth conductors must always have a yellow/green (PE) or yellow/green/blue (PEN) colour marking.

5.4.3 Backup fuses

For recommended fuse sizes, see section 21.1 [Supply voltage](#).

5.4.4 Additional protection

If the pump is connected to an electric installation where an earth leakage circuit breaker (ELCB) is used as additional protection, the circuit breaker must be of a type marked with the following symbols:

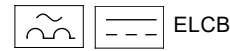

This circuit breaker is type B.

The total leakage current of all the electrical equipment in the installation must be taken into account.

The leakage current of the motor in normal operation can be seen in section 21.3 [Leakage current](#).

During start and at asymmetrical supply systems, the leakage current can be higher than normal and may cause the ELCB to trip.

5.4.5 Motor protection

The pump requires no external motor protection. The motor incorporates thermal protection against slow overloading and blocking (IEC 34-11, TP 211).

5.4.6 Protection against mains voltage transients

The pump is protected against mains voltage transients in accordance with EN 61800-3 and is capable of withstanding a VDE 0160 pulse.

The pump has a replaceable varistor which is part of the transient protection.

Over time this varistor will be worn and need to be replaced. When the time for replacement has come, R100 and PC Tool E-products will indicate this as a warning. See section 18. [Maintenance and service](#).

5.4.7 Supply voltage and mains

3 x 380-480 V - 10 %/+ 10 %, 50/60 Hz, PE.

The supply voltage and frequency are marked on the pump nameplate. Make sure that the motor is suitable for the power supply of the installation site.

The wires in the terminal box must be as short as possible. Excepted from this is the protective earth conductor which must be so long that it is the last one to be disconnected in case the cable is inadvertently pulled out of the cable entry.

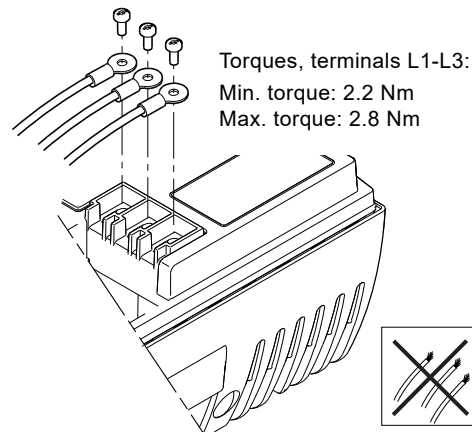

Fig. 13 Mains connection

Cable glands

Cable glands comply with EN 50626.

- 1 x M40 cable gland, cable diameter Ø16-Ø28
- 1 x M20 cable gland, cable diameter Ø9-Ø17
- 2 x M16 cable gland, cable diameter Ø4-Ø10
- 2 x M16 knock-out cable entries.



Warning
If the supply cable is damaged, it must be replaced by qualified staff.

Grid types

Three-phase E-pumps can be connected to all grid types.



Warning
Do not connect three-phase E-pumps to a mains supply with a voltage between phase and earth of more than 440 V.

5.4.8 Start/stop of pump



Caution The number of starts and stops via the mains voltage must not exceed 4 times per hour.

When the pump is switched on via the mains, it will start after approx. 5 seconds.

If a higher number of starts and stops is desired, use the input for external start/stop when starting/stopping the pump.

When the pump is switched on via an external on/off switch, it will start immediately.

5.4.9 Connections



Note If no external on/off switch is connected, connect terminals 2 and 3 using a short wire.

As a precaution, the wires to be connected to the following connection groups must be separated from each other by reinforced insulation in their entire lengths:

Group 1: Inputs

- start/stop, terminals 2 and 3
- digital input, terminals 1 and 9
- setpoint input, terminals 4, 5 and 6
- sensor input, terminals 7 and 8
- GENibus, terminals B, Y and A

All inputs (group 1) are internally separated from the mains-conducting parts by reinforced insulation and galvanically separated from other circuits.

All control terminals are supplied with protective extra-low voltage (PELV), thus ensuring protection against electric shock.

Group 2: Output (relay signal, terminals NC, C, NO)

The output (group 2) is galvanically separated from other circuits. Therefore, the supply voltage or protective extra-low voltage can be connected to the output as desired.

Group 3: Mains supply (terminals L1, L2, L3)

Group 4: Communication cable (8-pin male socket) - **only TPED**

The communication cable is connected to the socket in group 4. The cable ensures communication between the two pumps, whether one or two pressure sensors are connected. See section [5.7 Communication cable for TPED pumps](#).

The selector switch in group 4 enables changeover between the operating modes "alternating operation" and "standby operation". See description in section [6.2.1 Additional operating modes - TPED pumps](#).

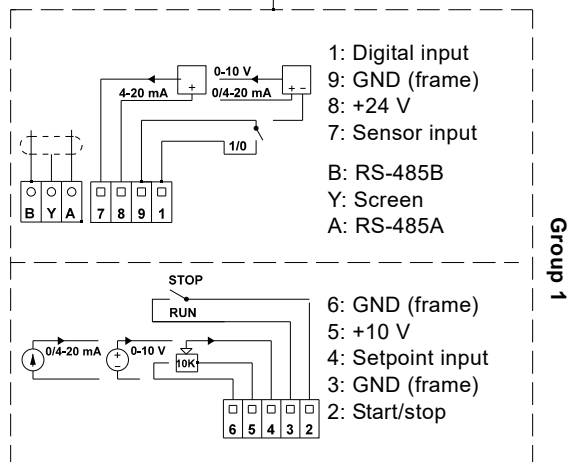
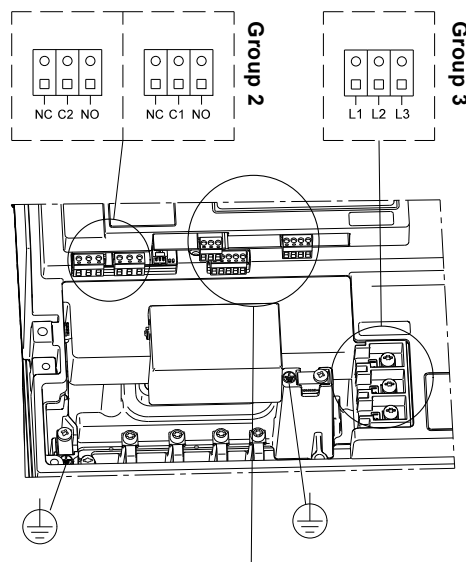

Fig. 14 Connection terminals - TPE, NKE, NKGE and NBE, NBGE, MTBE

TM03 8608 2007

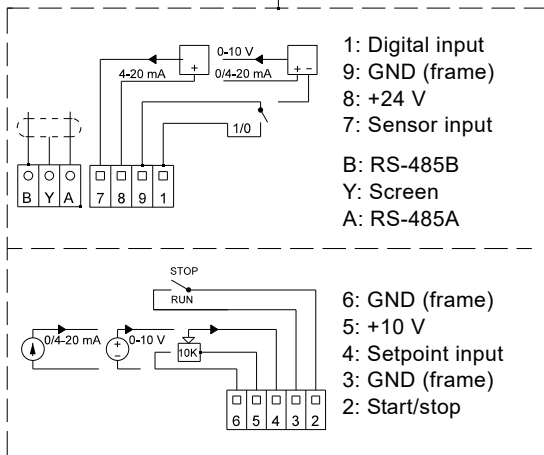
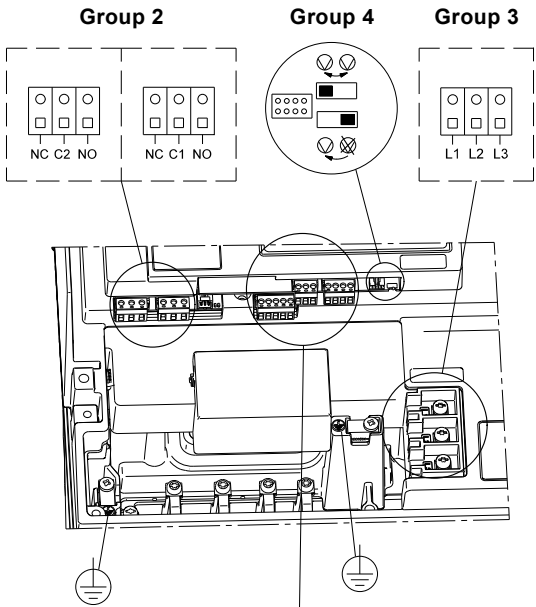

Fig. 15 Connection terminals - TPED

A galvanic separation must fulfil the requirements for reinforced insulation including creepage distances and clearances specified in EN 61800-5-1.

5.5 Signal cables

- Use screened cables with a conductor cross-section of min. 0.5 mm² and max. 1.5 mm² for external on/off switch, digital input, setpoint and sensor signals.
- Connect the screens of the cables to frame at both ends with good frame connection. The screens must be as close as possible to the terminals. See fig. 16.

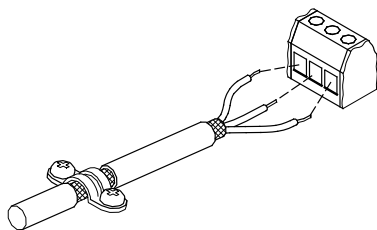

Fig. 16 Stripped cable with screen and wire connection

- Always tighten screws for frame connections whether a cable is fitted or not.
- Make the wires in the pump terminal box as short as possible.

5.6 Bus connection cable

5.6.1 New installations

For the bus connection, use a screened 3-core cable with a conductor cross-section of min. 0.2 mm² and max. 1.5 mm².

- If the pump is connected to a unit with a cable clamp which is identical to the one on the pump, connect the screen to this cable clamp.
- If the unit has no cable clamp as shown in fig. 17, leave the screen unconnected at this end.

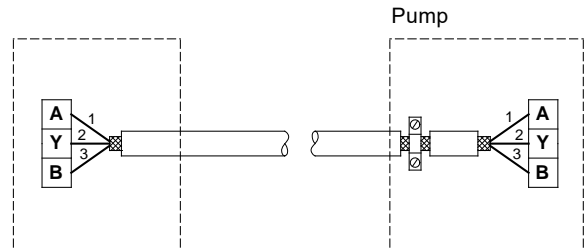

Fig. 17 Connection with screened 3-core cable

5.6.2 Replacing an existing pump

- If a screened 2-core cable is used in the existing installation, connect it as shown in fig. 18.

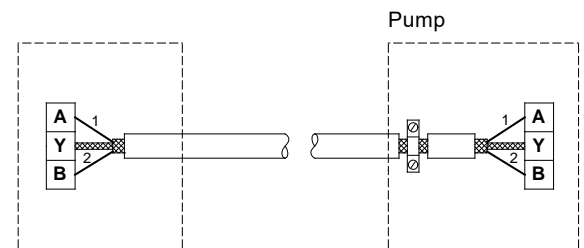

Fig. 18 Connection with screened 2-core cable

- If a screened 3-core cable is used in the existing installation, follow the instructions in section 5.6.1 *New installations*.

5.7 Communication cable for TPED pumps

The communication cable is connected between the two terminal boxes. The screen of the cable is connected to the frame at both ends with a good frame connection.

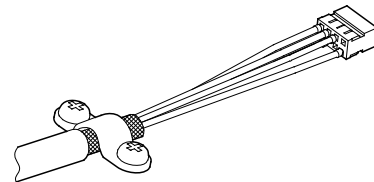

Fig. 19 Communication cable

The communication cable has a master end and a slave end as shown in fig. 20.

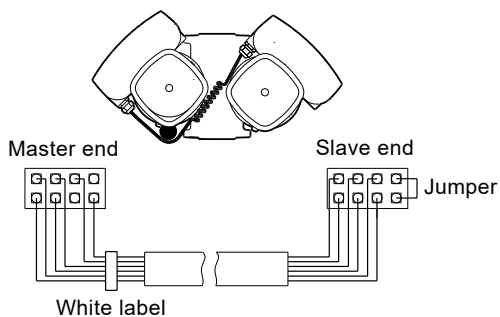

Fig. 20 Master end and slave end

On pumps with factory-fitted sensor, the master end and the sensor are connected to the same terminal box.

When the power supply to the two pumps has been switched off for 40 seconds and switched on again, the pump connected to the master end will start up first.

5.7.1 Connection of two sensors

The sensor signal is copied to the other pump through the red wire of the communication cable.

If, optionally, two sensors are connected (one sensor to each terminal box), cut the red wire. See fig. 21.

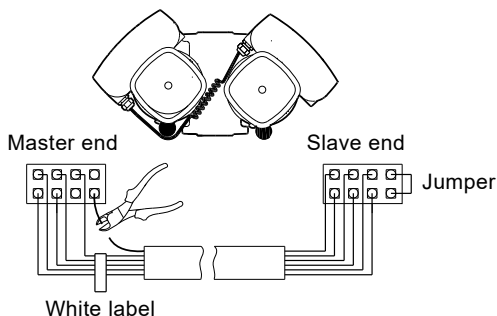

Fig. 21 Elimination of copied sensor signal

5.7.2 Elimination of alternating operation and standby operation

If alternating operation and standby operation are not desired, but the copied sensor signal (one sensor signal to two pumps) is desired, cut the green wire. See fig. 22.

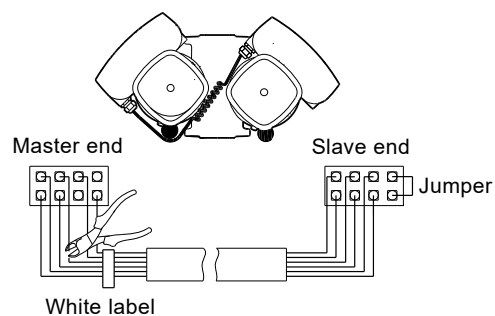

Fig. 22 Elimination of alternating operation and standby operation

5.7.3 Elimination of TPED function

If alternating operation and standby operation as well as the copied sensor signal are not desired, remove the communication cable completely.

6. Modes

Grundfos E-pumps are set and controlled according to operating and control modes.

6.1 Overview of modes

Operating modes	Normal	– Stop	– Min.	– Max.
Control modes	Uncontrolled	–	Controlled	
	Constant curve		Constant pressure ¹⁾	

1) In this example the pump is equipped with a differential pressure sensor. The pump may also be equipped with e.g. a temperature sensor in which case the description would be constant temperature in control mode controlled.

6.2 Operating mode

When the operating mode is set to Normal, the control mode can be set to controlled or uncontrolled. See section 6.3 *Control mode*.

The other operating modes that can be selected are Stop, Min. or Max.

- Stop: The pump has been stopped.
- Min.: The pump is operating at its minimum speed.
- Max.: The pump is operating at its maximum speed.

Figure 23 is a schematic illustration of min. and max. curves.

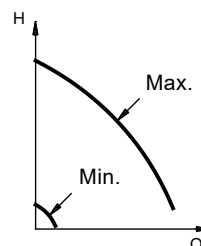

Fig. 23 Min. and max. curves

The max. curve can for instance be used in connection with the venting procedure during installation.

The min. curve can be used in periods in which a minimum flow is required.

If the power supply to the pump is disconnected, the mode setting will be stored.

The remote control R100 offers additional possibilities of setting and status displays. See section 8. *Setting by means of R100*.

TM00 5547 0995

TM04 5497 3309

TM04 5495 3309

TM04 5496 3309

6.2.1 Additional operating modes - TPED pumps

The TPED pumps offer the following additional operating modes:

- Alternating operation
Pump operation alternates every 24 hours. If the duty pump stops due to a fault, the other pump will start.
- Standby operation
One pump is operating continuously. In order to prevent seizing-up, the other pump is started 10 sec. every 24 hours. If the duty pump stops due to a fault, the other pump will start.

Select the operating mode by means of the selector switch in the terminal box. See figs 5, 9 and 15.

The selector switch enables changeover between the operating modes "alternating operation" (left position) and "standby operation" (right position).

The switches in the two terminal boxes must be set to the same position. If the switches are positioned differently, the pump will be in standby operation.

Twin-head pumps can be set and operated in the same way as single-head pumps. The duty pump uses its setpoint setting, whether it is made by means of the control panel, via the R100 or via bus.

Note Both pumps should be set to the same setpoint and control mode. Different settings will result in different operation when changing between the two pumps.

If the power supply to the pump is disconnected, the pump setting will be stored.

The remote control R100 offers additional possibilities of setting and status displays. See section 8. *Setting by means of R100.*

6.3 Control mode

The pump can be set to two control modes, i.e.

- controlled
- uncontrolled.

In control mode controlled, the pump will adjust its performance to the desired setpoint for the control parameter (pressure, differential pressure, temperature, differential temperature or flow).

In control mode uncontrolled, the pump will operate according to the constant curve set.

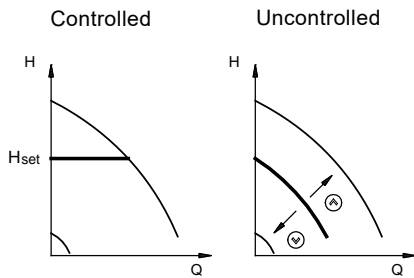

Fig. 24 Pump in control mode controlled (differential pressure control) and in control mode uncontrolled

The pumps have been factory-set to control mode uncontrolled. See section 6.4 *Factory setting.*

6.4 Factory setting

TPE, NKE, NKGE and NBE, NBGE, MTBE pumps

The pumps have been factory-set to uncontrolled operation. The setpoint value corresponds to 100 % of the maximum pump performance (see data sheet for the pump).

In sections 8.1 *Menu OPERATION* and 8.3 *Menu INSTALLATION*, the factory-setting is marked with bold-faced type under each individual display.

TPED pumps

The pumps have been factory-set to uncontrolled operation and the additional operating mode "alternating operation". The setpoint value corresponds to 100 % of the maximum pump performance (see data sheet for the pump).

In sections 8.1 *Menu OPERATION* and 8.3 *Menu INSTALLATION*, the factory-setting is marked with bold-faced type under each individual display.

7. Setting by means of control panel



Warning

At high system temperatures, the pump may be so hot that only the buttons should be touched to avoid burns.

The pump control panel, see fig. 25 or 26, incorporates the following buttons and indicator lights:

- Buttons, Ⓜ and Ⓜ, for setpoint setting.
- Light fields, yellow, for indication of setpoint.
- Indicator lights, green (operation) and red (fault).

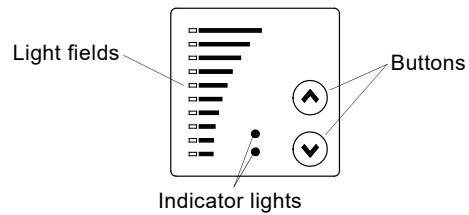

Fig. 25 Control panel, single-phase pumps

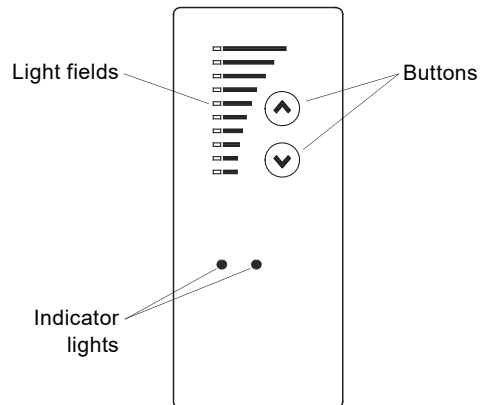

Fig. 26 Control panel, three-phase pumps

TM00 7600 0304

TM02 8513 0304

7.1 Setpoint setting

Note The setpoint can only be set when the operating mode is Normal.

Set the desired setpoint by pressing the button \odot or \ominus .

The light fields on the control panel will indicate the setpoint set. See examples in sections [7.1.1 Pump in control mode controlled \(differential pressure control\)](#) and [7.1.2 Pump in control mode uncontrolled](#).

7.1.1 Pump in control mode controlled (differential pressure control)

Example

Figure 27 shows that the light fields 5 and 6 are activated, indicating a desired setpoint of 3.4 m. The sensor measuring range is 0 to 6 m. The setting range is equal to the sensor measuring range (see sensor nameplate).

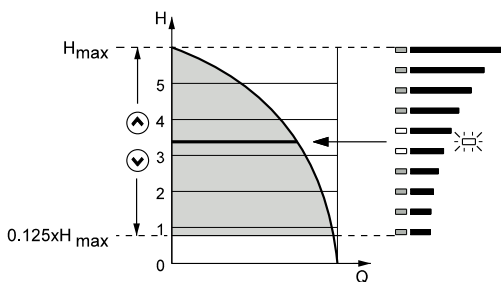

Fig. 27 Setpoint set to 3.4 m (differential pressure control)

7.1.2 Pump in control mode uncontrolled

Example

In control mode uncontrolled, the pump performance is set within the range from min. to max. curve, fig. 28.

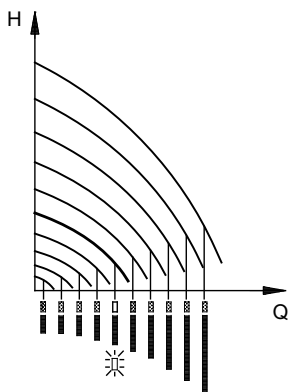

Fig. 28 Pump performance setting, control mode uncontrolled

7.2 Setting to max. curve duty

Press \odot continuously to change to the max. curve of the pump (top light field flashes).

To change back, press \ominus continuously until the desired setpoint is indicated.

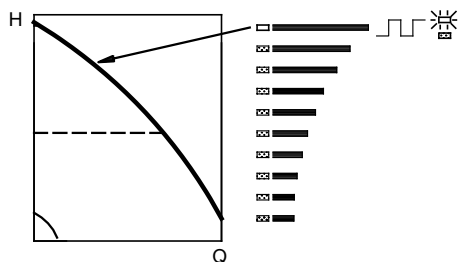

Fig. 29 Max. curve duty

7.3 Setting to min. curve duty

Press \ominus continuously to change to the min. curve of the pump (bottom light field flashes).

To change back, press \odot continuously until the desired setpoint is indicated.

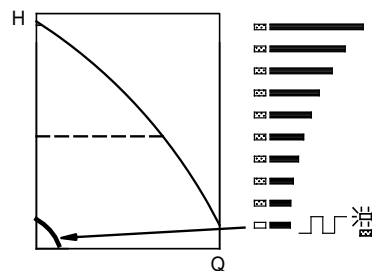

Fig. 30 Min. curve duty

7.4 Start/stop of pump

Start the pump by continuously pressing \odot until the desired setpoint is indicated.

Stop the pump by continuously pressing \ominus until none of the light fields are activated and the green indicator light flashes.

8. Setting by means of R100

The pump is designed for wireless communication with the Grundfos remote control R100.

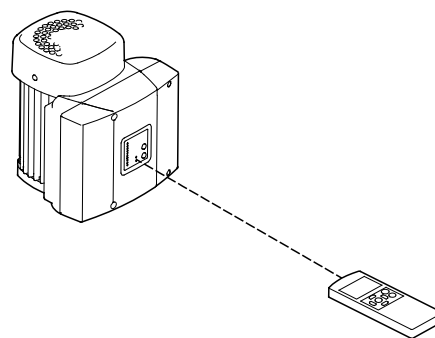

Fig. 31 R100 communicating with the pump via infra-red light

During communication, the R100 must be pointed at the control panel. When the R100 communicates with the pump, the red indicator light will flash rapidly. Keep pointing the R100 at the control panel until the red LED diode stops flashing.

The R100 offers setting and status displays for the pump.

The displays are divided into four parallel menus, fig. 32:

- 0. GENERAL (see operating instructions for the R100)
- 1. OPERATION
- 2. STATUS
- 3. INSTALLATION

The figure above each individual display in fig. 32 refers to the section in which the display is described.

TM00 7346 1304

TM03 5845 4006

TM00 7746 1304

TM00 7345 1304

TM02 0936 0501

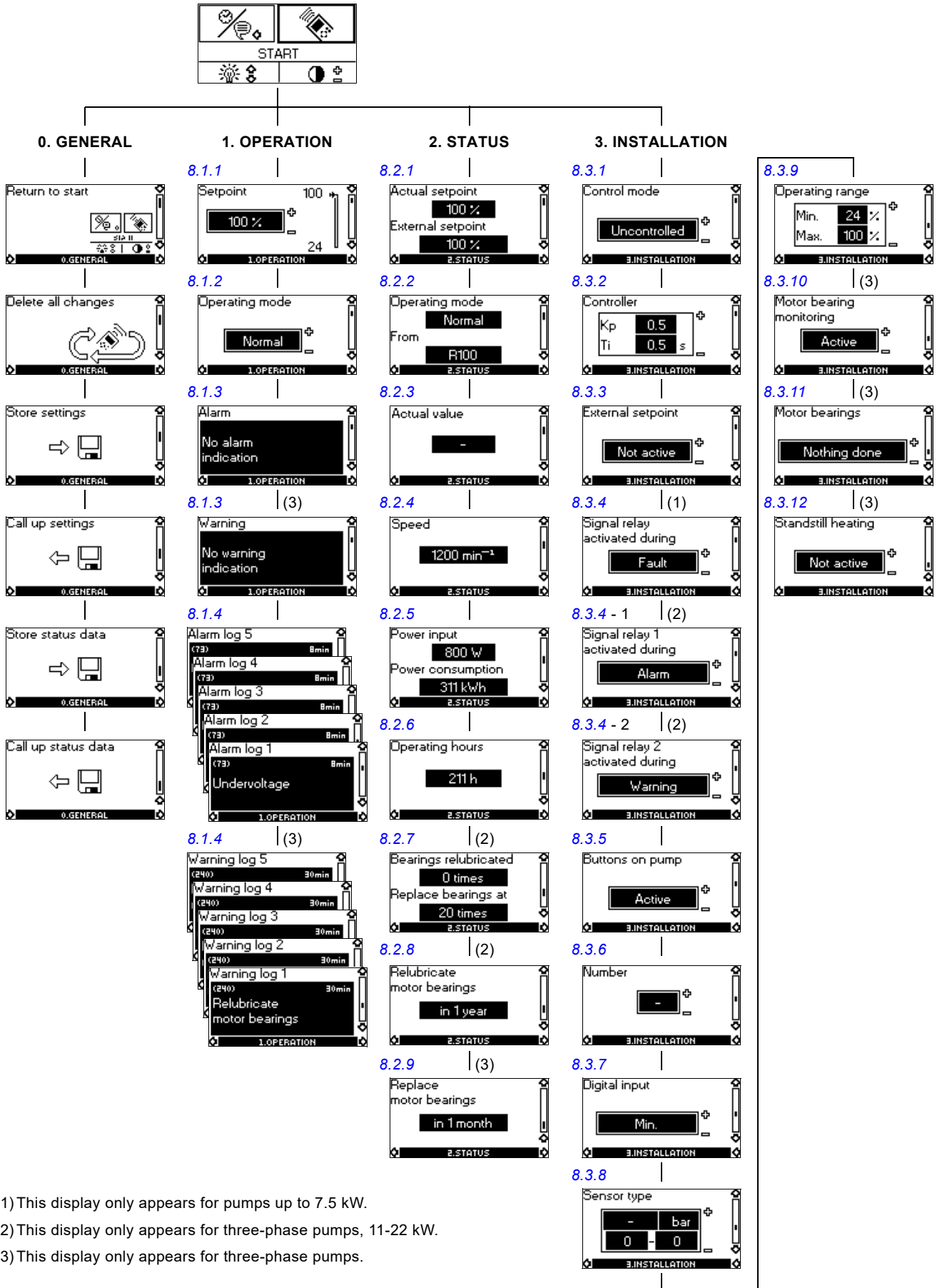

- (1) This display only appears for pumps up to 7.5 kW.
- (2) This display only appears for three-phase pumps, 11-22 kW.
- (3) This display only appears for three-phase pumps.

Fig. 32 Menu overview

8.1 Menu OPERATION

The first display in the menu is this.

8.1.1 Setpoint

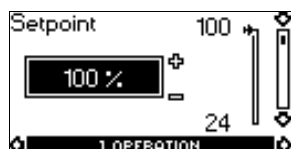

- ▶ Setpoint set
- Actual setpoint
- Actual value

Set the desired setpoint in this display.

In control mode controlled, the setting range is equal to the sensor measuring range, e.g. 0 to 25 m.

In control mode uncontrolled, the setpoint is set in % of the maximum performance. The setting range will lie between the min. and max. curves.

If the pump is connected to an external setpoint signal, the value in this display will be the maximum value of the external setpoint signal. See section [12. External setpoint signal](#).

Setpoint and external signal

The setpoint cannot be set if the pump is controlled via external signals (Stop, Min. curve or Max. curve). The R100 will give this warning: External control!

Check if the pump is stopped via terminals 2-3 (open circuit) or set to min. or max. via terminals 1-3 (closed circuit).

See section [10. Priority of settings](#).

Setpoint and bus communication

The setpoint cannot be set either if the pump is controlled from an external control system via bus communication. The R100 will give this warning: Bus control!

To override bus communication, disconnect the bus connection.

See section [10. Priority of settings](#).

8.1.2 Operating mode

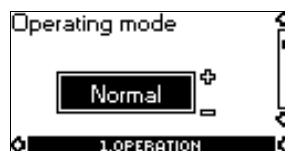

Set one of the following operating modes:

- Max.
- **Normal** (duty)
- Min.
- Stop.

The operating modes can be set without changing the setpoint setting.

8.1.3 Fault indications

In E-pumps, faults may result in two types of indication: alarm or warning.

An alarm fault will activate an alarm indication in the R100 and cause the pump to change operating mode, typically to stop. However, for some faults resulting in alarm, the pump is set to continue operating even if there is an alarm.

A warning fault will activate a warning indication in the R100, but the pump will not change operating or control mode.

Note

The indication "Warning" only applies to three-phase pumps.

Alarm



In case of alarm, the cause will appear in this display.

Possible causes:

- No alarm indication
- Too high motor temperature
- Undervoltage
- Mains voltage asymmetry (11-22 kW)
- Overvoltage
- Too many restarts (after faults)
- Overload
- Underload (11-22 kW)
- Sensor signal outside signal range
- Setpoint signal outside signal range
- External fault
- Other fault.

If the pump has been set up to manual restart, an alarm indication can be reset in this display if the cause of the fault has disappeared.

Warning (only three-phase pumps)

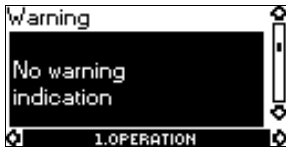

In case of warning, the cause will appear in this display.

Possible causes:

- No warning indication
- Sensor signal outside signal range
- Relubricate motor bearings (only 11-22 kW), see section [18.2 Relubrication of motor bearings](#)
- Replace motor bearings. See section [18.3 Replacement of motor bearings](#)
- Replace varistor (only 11-22 kW), see section [18.4 Replacement of varistor \(only 11-22 kW\)](#).

A warning indication will disappear automatically once the fault has been remedied.

8.1.4 Fault log

For both fault types, alarm and warning, the R100 has a log function.

Alarm log



In case of alarm faults, the last five alarm indications will appear in the alarm log. "Alarm log 1" shows the latest fault, "Alarm log 2" shows the latest fault but one, etc.

The example above gives this information:

- the alarm indication Undervoltage
- the fault code (73)
- the number of minutes the pump has been connected to the power supply after the fault occurred, 8 min.

Warning log (only three-phase pumps)

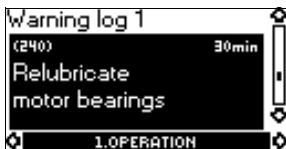

In case of warning faults, the last five warning indications will appear in the warning log. "Warning log 1" shows the latest fault, "Warning log 2" shows the latest fault but one, etc.

The example above gives this information:

- the warning indication Relubricate motor bearings
- the fault code (240)
- the number of minutes the pump has been connected to the power supply since the fault occurred, 30 min.

8.2 Menu STATUS

The displays appearing in this menu are status displays only. It is not possible to change or set values.

The displayed values are the values that applied when the last communication between the pump and the R100 took place. If a status value is to be updated, point the R100 at the control panel and press [OK].

If a parameter, e.g. speed, should be called up continuously, press [OK] constantly during the period in which the parameter in question should be monitored.

The tolerance of the displayed value is stated under each display. The tolerances are stated as a guide in % of the maximum values of the parameters.

8.2.1 Actual setpoint

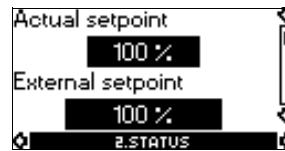

Tolerance: $\pm 2\%$

This display shows the actual setpoint and the external setpoint in % of the range from minimum value to the setpoint set. See section [12. External setpoint signal](#).

8.2.2 Operating mode



This display shows the actual operating mode (Stop, Min., Normal (duty) or Max.). Furthermore, it shows where this operating mode was selected (R100, Pump, Bus or External).

8.2.3 Actual value



This display shows the value actually measured by a connected sensor.

If no sensor is connected to the pump, "-" will appear in the display.

8.2.4 Speed



Tolerance: $\pm 5\%$

The actual pump speed will appear in this display.

8.2.5 Power input and power consumption

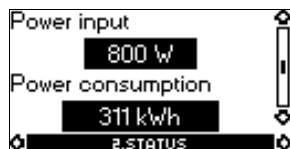

Tolerance: $\pm 10\%$

This display shows the actual pump input power from the mains supply. The power is displayed in W or kW.

The pump power consumption can also be read from this display. The value of power consumption is an accumulated value calculated from the pump's birth and it cannot be reset.

8.2.6 Operating hours



Tolerance: $\pm 2\%$

The value of operating hours is an accumulated value and cannot be reset.

8.2.7 Lubrication status of motor bearings (only 11-22 kW)



This display shows how many times the motor bearings have been relubricated and when to replace the motor bearings.

When the motor bearings have been relubricated, confirm this action in the INSTALLATION menu. See section [8.3.11 Confirming relubrication/replacement of motor bearings \(only three-phase pumps\)](#). When relubrication is confirmed, the figure in the above display will be increased by one.

8.2.8 Time till relubrication of motor bearings (only 11-22 kW)



This display shows when to relubricate the motor bearings. The controller monitors the operating pattern of the pump and calculates the period between bearing relubrications. If the operating pattern changes, the calculated time till relubrication may change as well.

The displayable values are these:

- in 2 years
- in 1 year
- in 6 months
- in 3 months
- in 1 month
- in 1 week
- Now!

8.2.9 Time till replacement of motor bearings (only three-phase pumps)

When the motor bearings have been relubricated, a prescribed number of times stored in the controller, the display in section [8.2.8 Time till relubrication of motor bearings \(only 11-22 kW\)](#) will be replaced by the display below.



This display shows when to replace the motor bearings. The controller monitors the operating pattern of the pump and calculates the period between bearing replacements.

The displayable values are these:

- in 2 years
- in 1 year
- in 6 months
- in 3 months
- in 1 month
- in 1 week
- Now!

8.3 Menu INSTALLATION

8.3.1 Control mode

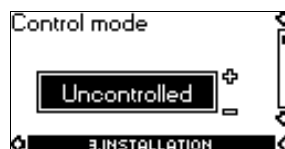

Select one of the following control modes (see fig. 24):

- Controlled
- **Uncontrolled.**

How to set the desired performance, see section [8.1.1 Setpoint](#).

Note

If the pump is connected to a bus, the control mode cannot be selected via the R100. See section [13. Bus signal](#).

8.3.2 Controller

E-pumps have a factory default setting of gain (K_p) and integral time (T_i). However, if the factory setting is not the optimum setting, the gain and the integral time can be changed in the display below.

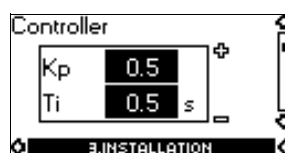

- The gain (K_p) can be set within the range from 0.1 to 20.
- The integral time (T_i) can be set within the range from 0.1 to 3600 s. If 3600 s is selected, the controller will function as a P controller.
- Furthermore, it is possible to set the controller to inverse control, meaning that if the setpoint is increased, the speed will be reduced. In the case of inverse control, the gain (K_p) must be set within the range from -0.1 to -20.

The table below shows the suggested controller settings:

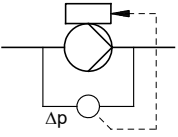
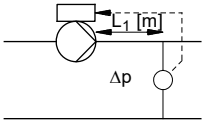
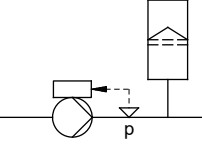
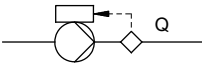
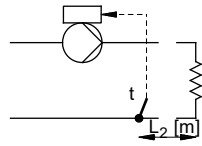
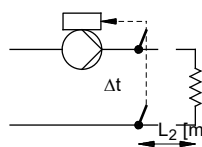
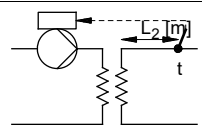
System/application	Kp		Ti
	Heating system ¹⁾	Cooling system ²⁾	
	0,5		0,5
	0,5		L ₁ < 5 m: 0,5 L ₁ > 5 m: 3 L ₁ > 10 m: 5
	0,5		0,5
	0,5		0,5
	0,5	- 0,5	10 + 5L ₂
	0,5		10 + 5L ₂
	0,5	- 0,5	30 + 5L ₂

1. Heating systems are systems in which an increase in pump performance will result in a rise in temperature at the sensor.
 2. Cooling systems are systems in which an increase in pump performance will result in a drop in temperature at the sensor.
- L₁ = Distance in [m] between pump and sensor.
L₂ = Distance in [m] between heat exchanger and sensor.

How to set the PI controller

For most applications, the factory setting of the controller constants Kp and Ti will ensure optimum pump operation. However, in some applications an adjustment of the controller may be needed.

Proceed as follows:

1. Increase the gain (Kp) until the motor becomes unstable. Instability can be seen by observing if the measured value starts to fluctuate. Furthermore, instability is audible as the motor starts hunting up and down. Some systems, such as temperature controls, are slow-reacting, meaning that it may be several minutes before the motor becomes unstable.
2. Set the gain (Kp) to half the value of the value which made the motor unstable. This is the correct setting of the gain.
3. Reduce the integral time (Ti) until the motor becomes unstable.
4. Set the integral time (Ti) to twice the value which made the motor unstable. This is the correct setting of the integral time.

General rules of thumb:

- If the controller is too slow-reacting, increase Kp.
- If the controller is hunting or unstable, dampen the system by reducing Kp or increasing Ti.

8.3.3 External setpoint



The input for external setpoint signal can be set to different signal types.

Select one of the following types:

- 0-10 V
- 0-20 mA
- 4-20 mA
- **Not active.**

If Not active is selected, the setpoint set by means of the R100 or on the control panel will apply.

If one of the signal types is selected, the actual setpoint is influenced by the signal connected to the external setpoint input. See section 12. [External setpoint signal](#).

8.3.4 Signal relay

Pumps up to 7.5 kW have one signal relay. The factory setting of the relay will be fault.

Pumps of 11-22 kW have two signal relays. Signal relay 1 is factory-set to alarm and signal relay 2 to warning.

In one of the displays below, select in which operating situation the signal relay should be activated.

Up to 7.5 kW



- Ready
- **Fault**
- Operation
- Pump running (only three-phase pumps up to 7.5 kW)
- Warning (only three-phase pumps up to 7.5 kW).

11-22 kW



- Ready
- **Alarm**
- Operation
- Pump running
- Warning
- Relubricate.

11-22 kW



- Ready
- **Alarm**
- Operation
- Pump running
- Warning
- Relubricate.

Fault and alarm cover faults resulting in alarm. Warning covers faults resulting in warning. relubricate covers only that one individual event. For distinction between alarm and warning, see section 8.1.3 [Fault indications](#).

For further information, see section 15. [Indicator lights and signal relay](#).

8.3.5 Buttons on pump



The operating buttons \odot and \ominus on the control panel can be set to these values:

- **Active**
- Not active.

When set to Not active (locked), the buttons do not function. Set the buttons to Not active if the pump should be controlled via an external control system.

8.3.6 Pump number



A number between 1 and 64 can be allocated to the pump. In the case of bus communication, a number must be allocated to each pump.

8.3.7 Digital input



The digital input of the pump (terminal 1, fig. 4, 8 or 14) can be set to different functions.

Select one of the following functions:

- **Min.** (min. curve)
- **Max.** (max. curve).

The selected function is activated by closing the contact between terminals 1 and 9. See figs 4, 8 and 14.

See also section 11.2 *Digital input*.

Min.:

When the input is activated, the pump will operate according to the min. curve.

Max.:

When the input is activated, the pump will operate according to the max. curve.

8.3.8 Sensor



The setting of the sensor is only relevant in the case of controlled operation.

Select among the following values:

- Sensor output signal
 - 0-10 V
 - 0-20 mA
 - 4-20 mA
- Unit of measurement of sensor:
 - bar, mbar, m, kPa, psi, ft, m³/h, m³/s, l/s, gpm, °C, °F, %
- Sensor measuring range.

8.3.9 Operating range

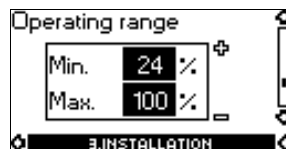

How to set the operating range:

- Set the min. curve within the range from max. curve to 12 % of maximum performance. The pump has been factory-set to 24 % of maximum performance.
- Set the max. curve within the range from maximum performance (100 %) to min. curve.

The area between the min. and max. curves is the operating range.

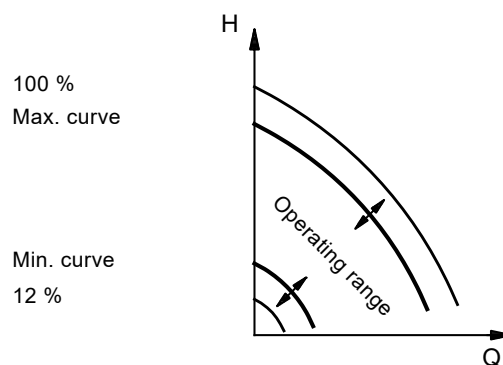

Fig. 33 Setting of the min. and max. curves in % of maximum performance

TM00 7747 1896

8.3.10 Motor bearing monitoring (only three-phase pumps)



The motor bearing monitoring function can be set to these values:

- **Active**
- Not active.

When the function is set to Active, a counter in the controller will start counting the mileage of the bearings. See section 8.2.7 *Lubrication status of motor bearings (only 11-22 kW)*.

The counter will continue counting even if the function is switched to Not active, but a warning will not be given when it is time for relubrication.

Note

When the function is switched to Active again, the accumulated mileage will again be used to calculate the relubrication time.

8.3.11 Confirming relubrication/replacement of motor bearings (only three-phase pumps)



This function can be set to these values:

- Relubricated (only 11-22 kW)
- Replaced
- **Nothing done.**

When the bearing monitoring function is Active, the controller will give a warning indication when the motor bearings are due to be relubricated or replaced. See section [8.1.3 Fault indications](#).

When the motor bearings have been relubricated or replaced, confirm this action in the above display by pressing [OK].

Note Relubricated cannot be selected for a period of time after confirming relubrication.

8.3.12 Standstill heating (only three-phase pumps)



The standstill heating function can be set to these values:

- Active
- **Not active.**

When the function is set to Active, a low voltage will be applied to the motor windings when the pump is not operating. The applied voltage will ensure that sufficient heat is generated to avoid condensation in the motor.

9. Setting by means of PC Tool E-products

Special setup requirements differing from the settings available via the R100 require the use of Grundfos PC Tool E-products. This again requires the assistance of a Grundfos service technician or engineer. Contact your local Grundfos company for more information.

10. Priority of settings

The priority of settings depends on two factors:

1. control source
2. settings.

1. Control source

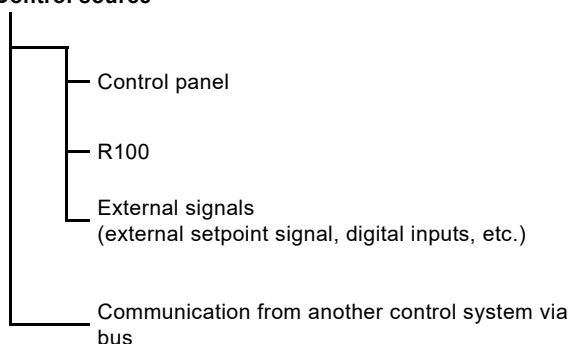

2. Settings

- Operating mode Stop
- Operating mode Max. (max. curve)
- Operating mode Min. (min. curve)
- Setpoint setting.

An E-pump can be controlled by different control sources at the same time, and each of these sources can be set differently. Consequently, it is necessary to set an order of priority of the control sources and the settings.

Note If two or more settings are activated at the same time, the pump will operate according to the function with the highest priority.

Priority of settings without bus communication

Priority	Control panel or R100	External signals
1	Stop	
2	Max.	
3		Stop
4		Max.
5	Min.	Min.
6	Setpoint setting	Setpoint setting

Example: If the E-pump has been set to operating mode Max. (max. frequency) via an external signal, such as digital input, the control panel or R100 can only set the E-pump to operating mode Stop.

Priority of settings with bus communication

Priority	Control panel or R100	External signals	Bus communication
1	Stop		
2	Max.		
3		Stop	Stop
4			Max.
5			Min.
6			Setpoint setting

Example: If the E-pump is operating according to a setpoint set via bus communication, the control panel or R100 can set the E-pump to operating mode Stop or Max., and the external signal can only set the E-pump to operating mode Stop.

11. External forced-control signals

The pump has inputs for external signals for these forced-control functions:

- Start/stop of pump
- Digital function.

11.1 Start/stop input

Functional diagram: Start/stop input

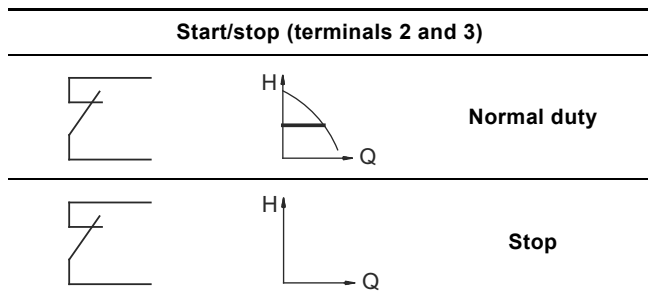

11.2 Digital input

By means of the R100, one of the following functions can be selected for the digital input:

- Normal duty
- Min. curve
- Max. curve.

Functional diagram: Input for digital function

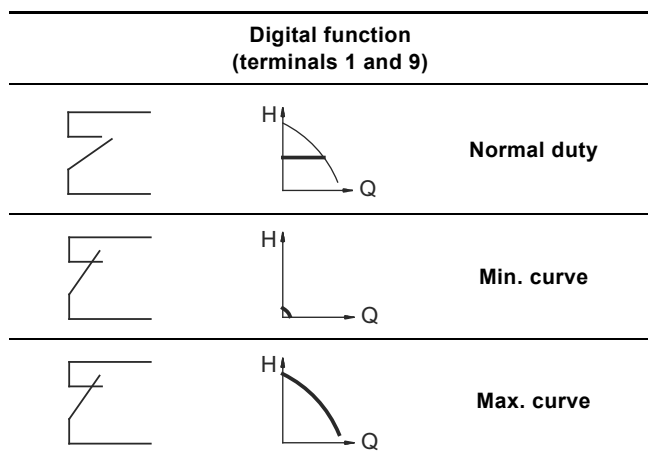

12. External setpoint signal

The setpoint can be remote-set by connecting an analogue signal transmitter to the input for the setpoint signal (terminal 4).

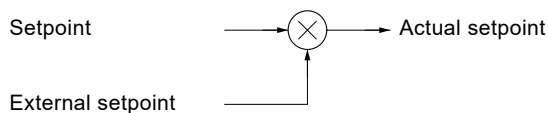

Fig. 34 Actual setpoint as a product (multiplied value) of setpoint and external setpoint

Select the actual external signal, 0-10 V, 0-20 mA, 4-20 mA, via the R100. See section 8.3.3 External setpoint.

If control mode uncontrolled is selected by means of the R100, the pump can be controlled by any controller.

In control mode controlled, the setpoint can be set externally within the range from sensor_{min} to the setpoint set on the pump or by means of the R100.

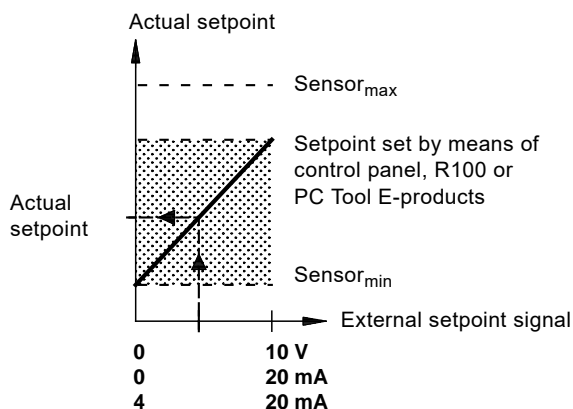

Fig. 35 Relation between the actual setpoint and the external setpoint signal in control mode controlled

Example: At a sensor_{min} value of 0 m, a setpoint set of 20 m and an external setpoint of 80 %, the actual setpoint will be as follows:

$$\begin{aligned}
 H_{\text{actual}} &= (H_{\text{set}} - H_{\text{min}}) \times \% \text{external setpoint} + H_{\text{min}} \\
 &= (20 - 0) \times 80 \% + 0 \\
 &= 16 \text{ m}
 \end{aligned}$$

In control mode uncontrolled, the setpoint can be set externally within the range from the min. curve to the setpoint set on the pump or by means of the R100.

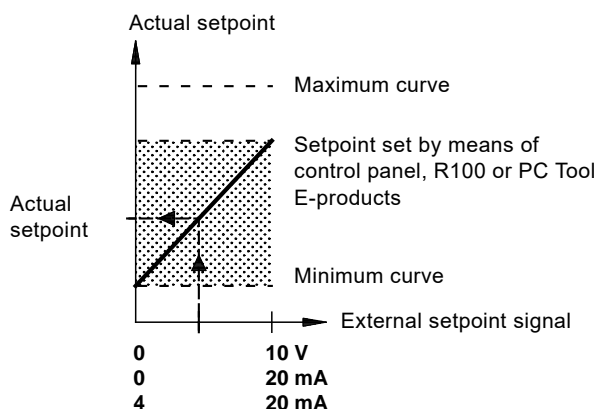

Fig. 36 Relation between the actual setpoint and the external setpoint signal in control mode open loop

TM03 8601 2007

TM02 8988 1304

TM02 8988 1304

13. Bus signal

The pump supports serial communication via an RS-485 input. The communication is carried out according to the Grundfos bus protocol, GENIbus protocol, and enables connection to a building management system or another external control system.

Operating parameters, such as setpoint, operating mode, etc. can be remote-set via the bus signal. At the same time, the pump can provide status information about important parameters, such as actual value of control parameter, input power, fault indications, etc.

Contact Grundfos for further details.

Note If a bus signal is used, the number of settings available via the R100 will be reduced.

14. Other bus standards

Grundfos offers various bus solutions with communication according to other standards.

15. Indicator lights and signal relay

The operating condition of the pump is indicated by the green and red indicator lights fitted on the pump control panel and inside the terminal box. See figs 37 and 38.

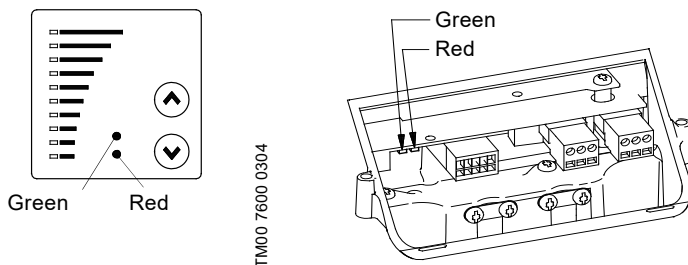

Fig. 37 Position of indicator lights on single-phase pumps

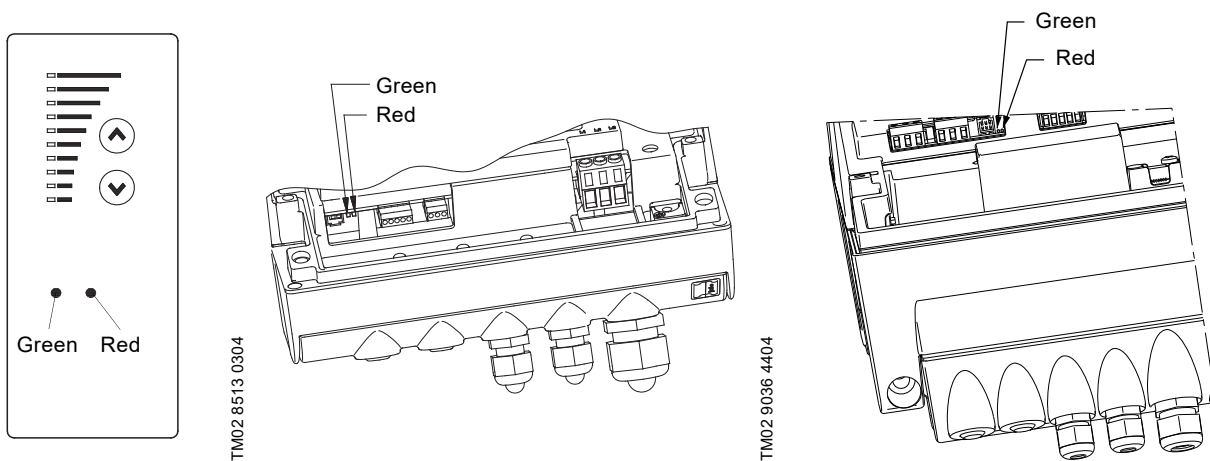

Fig. 38 Position of indicator lights on three-phase pumps

Besides, the pump incorporates an output for a potential-free signal via an internal relay.

For signal relay output values, see section [8.3.4 Signal relay](#).

The functions of the two indicator lights and the signal relay are as shown in the following table:

Indicator lights		Signal relay activated during:				Description
Fault (red)	Operation (green)	Fault/alarm, warning and relubricate	Operating	Ready	Pump running	
Off	Off					The power supply has been switched off.
Off	Permanently on					The pump is operating.
Off	Flashing					The pump has been set to stop.
Permanently on	Off					The pump has stopped because of a fault/ alarm or is running with a warning or relubricate indication. If the pump was stopped, restarting will be attempted (it may be necessary to restart the pump by resetting the fault indication).
Permanently on	Permanently on					The pump is operating, but it has or has had a fault/alarm allowing the pump to continue operation or it is operating with a warning or relubricate indication. If the cause is "sensor signal outside signal range", the pump will continue operating according to the max. curve and the fault indication cannot be reset until the signal is inside the signal range. If the cause is "setpoint signal outside signal range", the pump will continue operating according to the min. curve and the fault indication cannot be reset until the signal is inside the signal range.
Permanently on	Flashing					The pump has been set to stop, but it has been stopped because of a fault.

Resetting of fault indication

A fault indication can be reset in one of the following ways:

- Briefly press the button or on the pump. This will not change the setting of the pump. A fault indication cannot be reset by means of or if the buttons have been locked.
- Switch off the power supply until the indicator lights are off.
- Switch the external start/stop input off and then on again.
- Use the R100. See section 8.1.3 *Fault indications*.

When the R100 communicates with the pump, the red indicator light will flash rapidly.

16. Insulation resistance

Up to 7.5 kW

Caution

Do not measure the insulation resistance of motor windings or an installation incorporating E-pumps using high voltage megging equipment, as this may damage the built-in electronics.

11-22 kW

Caution

Do not measure the insulation resistance of an installation incorporating E-pumps using high voltage megging equipment, as this may damage the built-in electronics.

The motor conductors can be disconnected separately and the insulation resistance of the motor windings can be tested.

17. Emergency operation (only 11-22 kW)



Warning

Never make any connections in the pump terminal box unless all electric supply circuits have been switched off for at least 5 minutes.

Note for instance that the signal relay may be connected to an external supply which is still connected when the mains supply is disconnected.

If the pump has stopped and it does not restart after you have gone through normal remedies, the reason could be a faulty frequency converter. If this is the case, it is possible to establish emergency operation of the pump.

But before you change to emergency operation, we recommend you to check these points:

- Check that the mains supply is OK.
- Check that control signals are working (start/stop signals).
- Check that all alarms have been reset.
- Make a resistance test on the motor windings (disconnect the motor conductors from the terminal box).

If the pump still does not start, the frequency converter is faulty.

To establish emergency operation, proceed as follows:

1. Disconnect the three mains conductors, L1, L2, L3, from the terminal box, but leave the protective earth conductor(s) in position on the PE terminal(s).

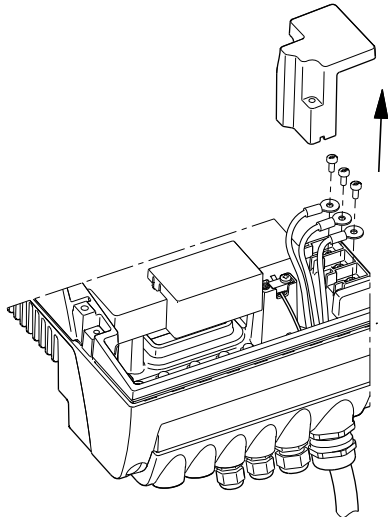

Fig. 39 Disconnecting the mains conductors

2. Disconnect the motor supply conductors, U/W1, V/U1, W/V1, from the terminal box.

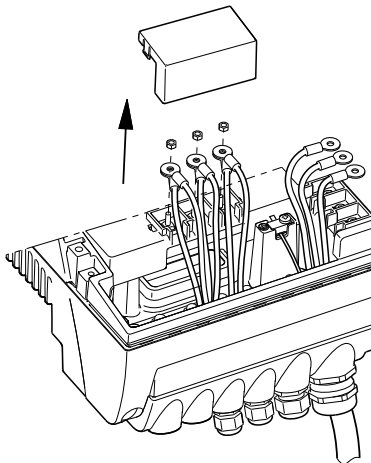

Fig. 40 Disconnecting the motor supply conductors

3. Connect the conductors as shown in fig. 41.

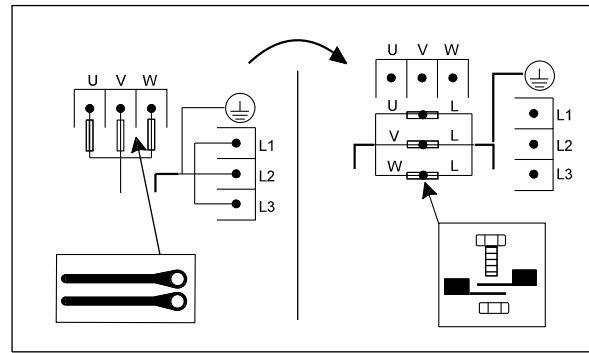

Fig. 41 How to switch an E-pump from normal operation to emergency operation

Use the screws from the mains terminals and the nuts from the motor terminals.

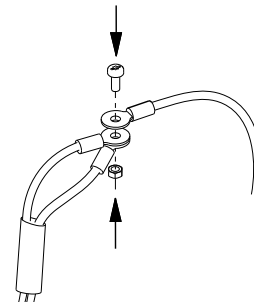

Fig. 42 Connecting the conductors

4. Insulate the three conductors from each other by means of insulating tape or the like.

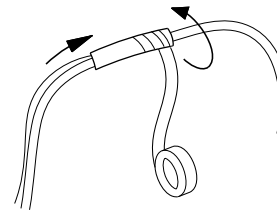

Fig. 43 Insulating the conductors

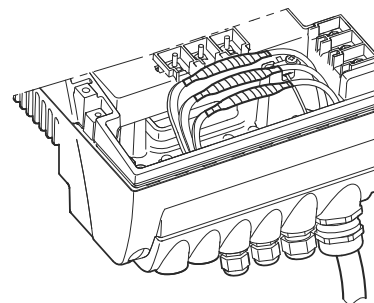

Fig. 44 Insulated conductors

Warning

Do not bypass the frequency converter by connecting the mains conductors to the U, V and W terminals.

This may cause hazardous situations for the staff as the high voltage potential of the mains may be transferred to touchable components in the terminal box.



Caution

Check the direction of rotation when starting up after switching to emergency operation.

18. Maintenance and service

18.1 Cleaning of the motor

Keep the motor cooling fins and fan blades clean to ensure sufficient cooling of the motor and electronics.

18.2 Relubrication of motor bearings

Pumps up to 7.5 kW

The motor bearings are of the closed type and greased for life. The bearings cannot be relubricated.

Pumps of 11-22 kW

The motor bearings are of the open type and must be relubricated regularly.

The motor bearings are pre-lubricated on delivery. The built-in bearing monitoring function will give a warning indication on the R100 when the motor bearings are due to be relubricated.

Note Before relubrication, remove the bottom plug in the motor flange and the plug in the bearing cover to ensure that old and excess grease can escape.

Frame size	Quantity of grease [ml]	
	Drive end	Non-drive end
MGE 160	13	13
MGE 180	15	15

When relubricating the first time, use the double quantity of grease as the lubricating channel is still empty.

The recommended grease type is a polycarbamide-based lubricating grease.

18.3 Replacement of motor bearings

Three-phase motors have built-in bearing monitoring function which will give a warning indication on the R100 when the motor bearings are due to be replaced.

18.4 Replacement of varistor (only 11-22 kW)

The varistor protects the pump against mains voltage transients. If voltage transients occur, the varistor will be worn over time and need to be replaced. The more transients, the more quickly the varistor will be worn. When it is time to replace the varistor, R100 and PC Tool E-products will indicate this as a warning.

A Grundfos technician is required for replacement of the varistor. Contact your local Grundfos company for assistance.

18.5 Service parts and service kits

For further information on service parts and service kits, visit www.Grundfos.com, select country, select WebCAPS.

19. Technical data - single-phase pumps

19.1 Supply voltage

1 x 200-240 V - 10 %/+ 10 %, 50/60 Hz - 2 %/+ 2 %, PE.

Recommended fuse size

Motor sizes up to 1.1 kW: Max. 10 A.

Standard as well as quick-blow or slow-blow fuses may be used.

19.2 Overload protection

The overload protection of the E-motor has the same characteristic as an ordinary motor protector. As an example, the E-motor can stand an overload of 110 % of I_{nom} for 1 min.

19.3 Leakage current

Earth leakage current < 3.5 mA.

The leakage currents are measured in accordance with EN 61800-5-1.

19.4 Inputs/outputs

Start/stop

External potential-free contact.

Voltage: 5 VDC.

Current: < 5 mA.

Screened cable: 0.5 - 1.5 mm² / 28-16 AWG.

Digital

External potential-free contact.

Voltage: 5 VDC.

Current: < 5 mA.

Screened cable: 0.5 - 1.5 mm² / 28-16 AWG.

Setpoint signals

- Potentiometer
0-10 VDC, 10 k Ω (via internal voltage supply).
Screened cable: 0.5 - 1.5 mm² / 28-16 AWG.
Maximum cable length: 100 m.
- Voltage signal
0-10 VDC, $R_i > 50$ k Ω .
Tolerance: + 0 %/- 3 % at maximum voltage signal.
Screened cable: 0.5 - 1.5 mm² / 28-16 AWG.
Maximum cable length: 500 m.
- Current signal
DC 0-20 mA/4-20 mA, $R_i = 175$ Ω .
Tolerance: + 0 %/- 3 % at maximum current signal.
Screened cable: 0.5 - 1.5 mm² / 28-16 AWG.
Maximum cable length: 500 m.

Sensor signals

- Voltage signal
0-10 VDC, $R_i > 50$ k Ω (via internal voltage supply).
Tolerance: + 0 %/- 3 % at maximum voltage signal.
Screened cable: 0.5 - 1.5 mm² / 28-16 AWG.
Maximum cable length: 500 m.
- Current signal
DC 0-20 mA/4-20 mA, $R_i = 175$ Ω .
Tolerance: + 0 %/- 3 % at maximum current signal.
Screened cable: 0.5 - 1.5 mm² / 28-16 AWG.
Maximum cable length: 500 m.

Internal power supplies

- 10 V power supply for external potentiometer:
Max. load: 2.5 mA.
Short-circuit-protected.
- 24 V power supply for sensors:
Max. load: 40 mA.
Short-circuit-protected.

Signal relay output

Potential-free changeover contact.

Maximum contact load: 250 VAC, 2 A, $\cos \varphi$ 0.3 - 1.

Minimum contact load: 5 VDC, 10 mA.

Screened cable: 0.5 - 2.5 mm² / 28-12 AWG.

Maximum cable length: 500 m.

Bus input

Grundfos bus protocol, GENibus protocol, RS-485.

Screened 3-core cable: 0.2 - 1.5 mm² / 28-16 AWG.

Maximum cable length: 500 m.

20. Technical data - three-phase pumps up to 7.5 kW

20.1 Supply voltage

3 x 380-480 V - 10 %/+ 10 %, 50/60 Hz - 2 %/+ 2 %, PE.

Recommended fuse sizes

Motor sizes from 0.55 to 5.5 kW: Max. 16 A.

Motor size 7.5 kW: Max. 32 A.

Standard as well as quick-blow or slow-blow fuses may be used.

20.2 Overload protection

The overload protection of the E-motor has the same characteristic as an ordinary motor protector. As an example, the E-motor can stand an overload of 110 % of I_{nom} for 1 min.

20.3 Leakage current

Motor size [kW]	Leakage current [mA]
0.55 to 3.0 (supply voltage < 460 V)	< 3.5
0.55 to 3.0 (supply voltage > 460 V)	< 5
4.0 to 5.5	< 5
7.5	< 10

The leakage currents are measured in accordance with EN 61800-5-1.

20.4 Inputs/output

Start/stop

External potential-free contact.

Voltage: 5 VDC.

Current: < 5 mA.

Screened cable: 0.5 - 1.5 mm² / 28-16 AWG.

Digital

External potential-free contact.

Voltage: 5 VDC.

Current: < 5 mA.

Screened cable: 0.5 - 1.5 mm² / 28-16 AWG.

Setpoint signals

- Potentiometer
0-10 VDC, 10 kΩ (via internal voltage supply).
Screened cable: 0.5 - 1.5 mm² / 28-16 AWG.
Maximum cable length: 100 m.
- Voltage signal
0-10 VDC, $R_i > 50 \text{ k}\Omega$.
Tolerance: + 0 %/- 3 % at maximum voltage signal.
Screened cable: 0.5 - 1.5 mm² / 28-16 AWG.
Maximum cable length: 500 m.
- Current signal
DC 0-20 mA/4-20 mA, $R_i = 175 \Omega$.
Tolerance: + 0 %/- 3 % at maximum current signal.
Screened cable: 0.5 - 1.5 mm² / 28-16 AWG.
Maximum cable length: 500 m.

Sensor signals

- Voltage signal
0-10 VDC, $R_i > 50 \text{ k}\Omega$ (via internal voltage supply).
Tolerance: + 0 %/- 3 % at maximum voltage signal.
Screened cable: 0.5 - 1.5 mm² / 28-16 AWG.
Maximum cable length: 500 m.
- Current signal
DC 0-20 mA/4-20 mA, $R_i = 175 \Omega$.
Tolerance: + 0 %/- 3 % at maximum current signal.
Screened cable: 0.5 - 1.5 mm² / 28-16 AWG.
Maximum cable length: 500 m.

Internal power supplies

- 10 V power supply for external potentiometer:
Max. load: 2.5 mA.
Short-circuit-protected.
- 24 V power supply for sensors:
Max. load: 40 mA.
Short-circuit-protected.

Signal relay output

Potential-free changeover contact.

Maximum contact load: 250 VAC, 2 A, $\cos \varphi 0.3 - 1$.

Minimum contact load: 5 VDC, 10 mA.

Screened cable: 0.5 - 2.5 mm² / 28-12 AWG.

Maximum cable length: 500 m.

Bus input

Grundfos bus protocol, GENIbus protocol, RS-485.

Screened 3-core cable: 0.2 - 1.5 mm² / 28-16 AWG.

Maximum cable length: 500 m.

21. Technical data - three-phase pumps, 11-22 kW

21.1 Supply voltage

3 x 380-480 V - 10 %/+ 10 %, 50/60 Hz - 3 %/+ 3 %, PE.

Recommended fuse sizes

Motor size [kW]		Max. [A]
2-pole	4-pole	
11	11	32
15	15	36
18.5	18.5	43
22	22	51

Standard as well as quick-blow or slow-blow fuses may be used.

21.2 Overload protection

The overload protection of the E-motor has the same characteristic as an ordinary motor protector. As an example, the E-motor can stand an overload of 110 % of I_{nom} for 1 min.

21.3 Leakage current

Earth leakage current greater than 10 mA.

The leakage currents are measured in accordance with EN 61800-5-1.

21.4 Inputs/output

Start/stop

External potential-free contact.

Voltage: 5 VDC.

Current: < 5 mA.

Screened cable: 0.5 - 1.5 mm² / 28-16 AWG.

Digital

External potential-free contact.

Voltage: 5 VDC.

Current: < 5 mA.

Screened cable: 0.5 - 1.5 mm² / 28-16 AWG.

Setpoint signals

- Potentiometer
0-10 VDC, 10 kΩ (via internal voltage supply).
Screened cable: 0.5 - 1.5 mm² / 28-16 AWG.
Maximum cable length: 100 m.
- Voltage signal
0-10 VDC, R_i > 50 kΩ.
Tolerance: + 0 %/- 3 % at maximum voltage signal.
Screened cable: 0.5 - 1.5 mm² / 28-16 AWG.
Maximum cable length: 500 m.
- Current signal
DC 0-20 mA/4-20 mA, R_i = 250 Ω.
Tolerance: + 0 %/- 3 % at maximum current signal.
Screened cable: 0.5 - 1.5 mm² / 28-16 AWG.
Maximum cable length: 500 m.

Sensor signals

- Voltage signal
0-10 VDC, R_i > 50 kΩ (via internal voltage supply).
Tolerance: + 0 %/- 3 % at maximum voltage signal.
Screened cable: 0.5 - 1.5 mm² / 28-16 AWG.
Maximum cable length: 500 m.
- Current signal
DC 0-20 mA/4-20 mA, R_i = 250 Ω.
Tolerance: + 0 %/- 3 % at maximum current signal.
Screened cable: 0.5 - 1.5 mm² / 28-16 AWG.
Maximum cable length: 500 m.

Internal power supplies

- 10 V power supply for external potentiometer:
Max. load: 2.5 mA.
Short-circuit-protected.
- 24 V power supply for sensors:
Max. load: 40 mA.
Short-circuit-protected.

Signal relay output

Potential-free changeover contact.

Maximum contact load: 250 VAC, 2 A, cos φ 0.3 - 1.

Minimum contact load: 5 VDC, 10 mA.

Screened cable: 0.5 - 2.5 mm² / 28-12 AWG.

Maximum cable length: 500 m.

Bus input

Grundfos bus protocol, GENIbus protocol, RS-485.

Screened 3-core cable: 0.2 - 1.5 mm² / 28-16 AWG.

Maximum cable length: 500 m.

22. Other technical data

EMC (electromagnetic compatibility to EN 61800-3)

Motor [kW]		Emission/immunity
2-pole	4-pole	
0.12	0.12	Emission: Motors may be installed in residential areas (first environment), unrestricted distribution, corresponding to CISPR11, group 1, class B. Immunity: Motors fulfil the requirements for both the first and second environment.
0.18	0.18	
0.25	0.25	
0.37	0.37	
0.55	0.55	
0.75	0.75	
1.1	1.1	
1.5	1.5	
2.2	2.2	
3.0	3.0	
4.0	4.0	Emission: The motors are category C3, corresponding to CISPR11, group 2, class A, and may be installed in industrial areas (second environment). If equipped with an external Grundfos EMC filter, the motors are category C2, corresponding to CISPR11, group 1, class A, and may be installed in residential areas (first environment).
5.5	-	
7.5	-	
-	5.5	
-	7.5	
11	11	
15	15	
18.5	18.5	
22	-	



Warning

When the motors are installed in residential areas, supplementary measures may be required as the motors may cause radio interference.

Motor sizes 11, 18.5 and 22 kW comply with EN 61000-3-12 provided that the short-circuit power at the interface point between the user's electrical installation and the public power supply network is greater than or equal to the values stated below. It is the responsibility of the installer or user to ensure, by consultation with the power supply network operator, if necessary, that the motor is connected to a power supply with a short-circuit power greater than or equal to these values:

Motor size [kW]	Short-circuit power [kVA]
11	1500
15	-
18.5	2700
22	3000

Note 15 kW motors do not comply with EN 61000-3-12.

By installing an appropriate harmonic filter between the motor and the power supply, the harmonic current content will be reduced. In this way the 15 kW motor will comply with EN 61000-3-12.

Immunity:

The motors fulfil the requirements for both the first and second environment.

Contact Grundfos for further information.

Enclosure class

- Single-phase pumps: IP55 (IEC 34-5).
- Three-phase pumps, 0.55 - 7.5 kW: IP55 (IEC 34-5).
- Three-phase pumps, 11-22 kW: IP55 (IEC 34-5).

Insulation class

F (IEC 85).

Ambient temperature

During operation:

- Min. -20 °C
- Max. +40 °C, without derating

During storage/transport:

- -30 - +60 °C (up to 7.5 kW)
- -25- +70 °C (11-22 kW).

Relative air humidity

Maximum 95 %.

Sound pressure level**Single-phase pumps:**

< 70 dB(A).

Three-phase pumps

Motor [kW]	Speed stated on nameplate [min ⁻¹]		Sound pressure level [dB(A)]
	2-pole	4-pole	
0.55		1400-1500	47
		1700-1800	52
0.75		1400-1500	47
		1700-1800	52
	2800-3000		60
	3400-3600		65
1.1		1400-1500	49
		1700-1800	53
	2800-3000		60
	3400-3600		65
1.5		1400-1500	53
		1700-1800	57
	2800-3000		65
	3400-3600		70
2.2		1400-1500	50
		1700-1800	52
	2800-3000		65
	3400-3600		70
3.0		1400-1500	55
		1700-1800	60
	2800-3000		65
	3400-3600		70
4.0		1400-1500	58
		1700-1800	63
	2800-3000		70
	3400-3600		75
5.5		1400-1500	57
		1700-1800	59
	2800-3000		75
	3400-3600		80
7.5		1400-1500	59
		1700-1800	61
	2800-3000		67
	3400-3600		72
11		1400-1500	63
		1700-1800	64
	2800-3000		64
	3400-3600		68
15		1400-1500	65
		1700-1800	66
	2800-3000		65
	3400-3600		68
18.5		1400-1500	69
		1700-1800	72
	2800-3000		69
	3400-3600		70
22		1400-1500	-
		1700-1800	-
	2800-3000		67
	3400-3600		70

23. Disposal

This product or parts of it must be disposed of in an environmentally sound way:

1. Use the public or private waste collection service.
2. If this is not possible, contact the nearest Grundfos company or service workshop.

Appendix

1. Installation in the USA and Canada

Note

In order to maintain the UL/cURus approval, follow these additional installation instructions. The UL approval is according to UL508C.

1.1 Electrical connection

1.1.1 Conductors

Use 140/167 °F (60/75 °C) copper conductors only.

1.1.2 Torques

Power terminals

Motor size [kW]	Thread size	Torque [Nm]
Up to 7.5 kW	M4	2.35
11-22 kW	M4	Min. 2.2 Max. 2.8

Relay, M2.5: 0.5 Nm.

Input control, M2: 0.2 Nm.

1.1.3 Line reactors

Max line reactor size must not exceed 2 mH.

1.1.4 Fuse size/circuit breaker

If a short circuit happens the pump can be used on a mains supply delivering not more than 5000 RMS symmetrical amperes, 600 V maximum.

Fuses

When the pump is protected by fuses they must be rated for 480 V. Maximum sizes are stated in table below.

Motors up to and including 7.5 kW require class K5 UL-listed fuses. Any UL-listed fuse can be used for motors from 11 to 22 kW.

Circuit breaker

When the pump is protected by a circuit breaker this must be rated for a maximum voltage of 480 V. The circuit breaker must be of the "Inverse time" type.

The interrupting rating (RMS symmetrical amperes) must not be less than the values stated in table below.

USA - hp

2-pole	4-pole	Fuse size	Circuit breaker type/model
1	1	25 A	25 A / Inverse time
1.5	1.5	25 A	25 A / Inverse time
2	2	25 A	25 A / Inverse time
3	3	25 A	25 A / Inverse time
5	5	40 A	40 A / Inverse time
7.5	-	40 A	40 A / Inverse time
10	7.5	50 A	50 A / Inverse time
15	15	80 A	80 A / Inverse time
20	20	110 A	110 A / Inverse time
25	25	125 A	125 A / Inverse time
30	-	150 A	150 A / Inverse time

Europe - kW

2-pole	4-pole	Fuse size	Circuit breaker type/model
-	0.55	25 A	25 A / Inverse time
0.75	0.75	25 A	25 A / Inverse time
1.1	1.1	25 A	25 A / Inverse time
1.5	1.5	25 A	25 A / Inverse time
2.2	2.2	25 A	25 A / Inverse time
3	3	25 A	25 A / Inverse time
4	4	40 A	40 A / Inverse time
5.5	-	40 A	40 A / Inverse time
7.5	5.5	50 A	50 A / Inverse time
11	11	80 A	80 A / Inverse time
15	15	110 A	110 A / Inverse time
18.5	18.5	125 A	125 A / Inverse time
22	-	150 A	150 A / Inverse time

1.1.5 Overload protection

Degree of overload protection provided internally by the drive, in percent of full-load current: 102 %.

1.2 General considerations

For installation in humid environment and fluctuating temperatures, it is recommended to keep the pump connected to the power supply continuously. This will prevent moisture and condensation build-up in the terminal box.

Start and stop must be done via the start/stop digital input (terminal 2-3).

96782376 04.2021

ECM: 1310103

Trademarks displayed in this material, including but not limited to Grundfos, the Grundfos logo and "be think innovate" are registered trademarks owned by The Grundfos Group. All rights reserved. © 2021 Grundfos Holding A/S. All rights reserved.