

TPE, TPED Series 2000

Installation and operating instructions



Original installation and operating instructions.

CONTENTS

	Page		
1. Symbols used in this document	2	21.3 Leakage current	28
2. General information	2	21.4 Inputs/output	28
3. General description	2	22. Technical data - three-phase pumps, 11-22 kW	29
3.1 Settings	2	22.1 Supply voltage	29
3.2 Twin-head pumps	2	22.2 Overload protection	29
4. Mechanical installation	3	22.3 Leakage current	29
4.1 Motor cooling	3	22.4 Inputs/output	29
4.2 Outdoor installation	3	23. Other technical data	29
5. Electrical connection	3	24. Disposal	31
5.1 Cable requirements	3		
5.2 Electrical connection - single-phase pumps	3		
5.3 Electrical connection - three-phase pumps up to 7.5 kW	6		
5.4 Electrical connection - three-phase pumps, 11-22 kW	8		
5.5 Signal cables	11		
5.6 Bus connection cable	11		
5.7 Communication cable for TPED pumps	11		
6. Modes	12		
6.1 Overview of modes	12		
6.2 Operating mode	12		
6.3 Control mode	12		
6.4 Factory setting	13		
7. Setting by means of control panel, single-phase pumps	14		
7.1 Setting of head	14		
7.2 Setting to max. curve duty	14		
7.3 Setting to min. curve duty	14		
7.4 Start/stop of pump	14		
8. Setting by means of control panel, three-phase pumps	15		
8.1 Setting of control mode	15		
8.2 Setting of head	15		
8.3 Setting to max. curve duty	15		
8.4 Setting to min. curve duty	16		
8.5 Start/stop of pump	16		
9. Setting by means of R100	16		
9.1 Menu OPERATION	18		
9.2 Menu STATUS	19		
9.3 Menu INSTALLATION	20		
10. Setting by means of PC Tool E-products	22		
11. Priority of settings	22		
12. External forced-control signals	22		
12.1 Start/stop input	22		
12.2 Digital input	22		
13. External setpoint signal	23		
14. Bus signal	23		
15. Other bus standards	23		
16. Indicator lights and signal relay	24		
17. Insulation resistance	26		
18. Emergency operation (only 11-22 kW)	26		
19. Maintenance and service	27		
19.1 Cleaning of the motor	27		
19.2 Relubrication of motor bearings	27		
19.3 Replacement of motor bearings	27		
19.4 Replacement of varistor (only 11-22 kW)	27		
19.5 Service parts and service kits	27		
20. Technical data - single-phase pumps	28		
20.1 Supply voltage	28		
20.2 Overload protection	28		
20.3 Leakage current	28		
20.4 Inputs/outputs	28		
21. Technical data - three-phase pumps up to 7.5 kW	28		
21.1 Supply voltage	28		
21.2 Overload protection	28		

**Warning**

Prior to installation, read these installation and operating instructions. Installation and operation must comply with local regulations and accepted codes of good practice.

1. Symbols used in this document**Warning**

If these safety instructions are not observed, it may result in personal injury!

**Warning**

The surface of the product may be so hot that it may cause burns or personal injury.

**Caution**

If these safety instructions are not observed, it may result in malfunction or damage to the equipment.

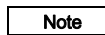
**Note**

Notes or instructions that make the job easier and ensure safe operation.

2. General information

These installation and operating instructions are a supplement to installation and operating instructions for the corresponding standard pumps TP, TPD. For instructions not mentioned specifically here, please see installation and operating instructions for the standard pump.

3. General description

Grundfos TPE, TPED Series 2000 pumps have standard motors with integrated frequency converter. The pumps are for single-phase or three-phase mains connection.

The pumps have a built-in PI controller and are set up with a differential-pressure sensor enabling control of the differential pressure across the pump.

The pumps are typically used as circulator pumps in large heating or cooling water systems with variable demands.

3.1 Settings

The desired setpoint can be set in three different ways:

- directly on the pump control panel.
It is possible to choose between two different control modes, i.e. proportional pressure and constant pressure.
- via an input for external setpoint signal
- by means of the Grundfos wireless remote control R100.

All other settings are made by means of the R100. Important parameters such as actual value of control parameter, power consumption, etc. can be read via the R100.

3.2 Twin-head pumps

Twin-head pumps do not require any external controller.

4. Mechanical installation

Note

In order to retain the UL/cURus approval, follow the additional installation procedures on page 32.

4.1 Motor cooling

To ensure sufficient cooling of motor and electronics, observe the following requirements:

- Make sure that sufficient cooling air is available.
- Keep the temperature of the cooling air below 40 °C.
- Keep cooling fins and fan blades clean.

4.2 Outdoor installation

When installed outdoors, the pump must be provided with a suitable cover to avoid condensation on the electronic components. See fig. 1.

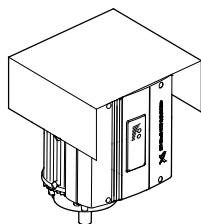

Fig. 1 Example of cover

Remove the drain plug pointing downwards in order to avoid moisture and water build-up inside the motor.

Vertically mounted pumps are IP55 after removal of the drain plug. Horizontally mounted pumps change enclosure class to IP54.

5. Electrical connection

For description of how to connect E-pumps electrically, see the following pages:

[5.2 Electrical connection - single-phase pumps](#) on page 3

[5.3 Electrical connection - three-phase pumps up to 7.5 kW](#) on page 6

[5.4 Electrical connection - three-phase pumps, 11-22 kW](#) on page 8.

5.1 Cable requirements

5.1.1 Cable size

Single-phase supply

1.5 mm² / 12-14 AWG.

Three-phase supply

6-10 mm² / 10-8 AWG.

5.1.2 Conductors

Type

Stranded copper conductors only.

Temperature rating

Temperature rating for conductor insulation: 60 °C (140 °F).

Temperature rating for outer cable sheath: 75 °C (167 °F).

5.2 Electrical connection - single-phase pumps



Warning

The user or the installer is responsible for the installation of correct earthing and protection according to local standards. All operations must be carried out by qualified staff.



Warning

Never make any connections in the pump terminal box unless all electric supply circuits have been switched off for at least 5 minutes.

Note for instance that the signal relay may be connected to an external supply which is still connected when the mains supply is disconnected.

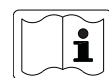

The above warning is indicated on the motor terminal box by this yellow label.



Warning

The surface of the terminal box may be above 70 °C when the pump is operating.

5.2.1 Preparation

Before connecting the E-pump to the mains, take the issues illustrated in the figure below into consideration.

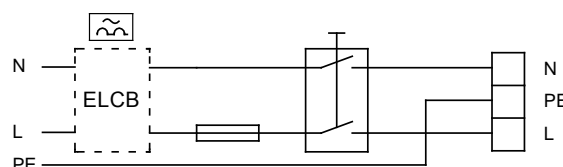

Fig. 2 Mains-connected pump with mains switch, backup fuse, additional protection and protective earthing

5.2.2 Protection against electric shock - indirect contact



Warning

The pump must be earthed and protected against indirect contact in accordance with local regulations.

Protective earth conductors must always have a yellow/green (PE) or yellow/green/blue (PEN) colour marking.

5.2.3 Backup fuses

For recommended fuse sizes, see section [20.1 Supply voltage](#).

5.2.4 Additional protection

If the pump is connected to an electric installation where an earth leakage circuit breaker (ELCB) is used as additional protection, the circuit breaker must be of a type marked with the following symbol:



ELCB

The total leakage current of all the electrical equipment in the installation must be taken into account.

The leakage current of the motor in normal operation can be seen in section [20.3 Leakage current](#).

During start and at asymmetrical supply systems, the leakage current can be higher than normal and may cause the ELCB to trip.

TM02 8514 0304

TM02 0792 0101

5.2.5 Motor protection

The pump requires no external motor protection. The motor incorporates thermal protection against slow overloading and blocking (IEC 34-11, TP 211).

5.2.6 Protection against mains voltage transients

The pump is protected against voltage transients by built-in varistors between phase-neutral and phase-earth.

5.2.7 Supply voltage and mains

1 x 200-240 V - 10 %/+ 10 %, 50/60 Hz, PE.

The supply voltage and frequency are marked on the pump nameplate. Make sure that the motor is suitable for the power supply of the installation site.

The wires in the terminal box must be as short as possible. Excepted from this is the protective earth conductor which must be so long that it is the last one to be disconnected in case the cable is inadvertently pulled out of the cable entry.

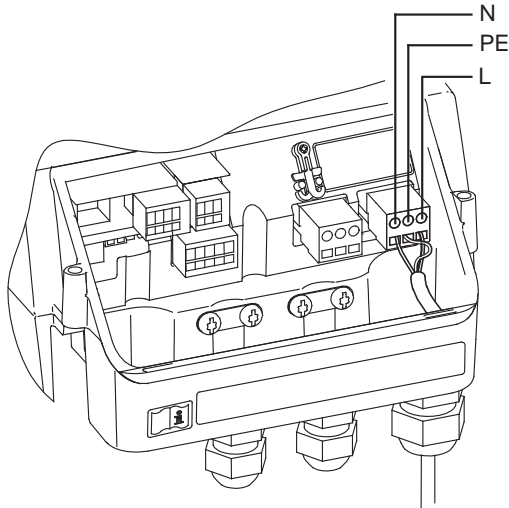

Fig. 3 Mains connection

Cable glands

Cable glands comply with EN 50626.

- 2 x M16 cable gland, cable diameter $\varnothing 4$ - $\varnothing 10$
- 1 x M20 cable gland, cable diameter $\varnothing 10$ - $\varnothing 14$
- 1 knock out for M16 cable gland.



Warning

If the supply cable is damaged, it must be replaced by qualified staff.

Grid types

Single-phase E-pumps can be connected to all grid types.



Warning

Do not connect single-phase E-pumps to a mains supply with a voltage between phase and earth of more than 250 V.

5.2.8 Start/stop of pump

Caution

The number of starts and stops via the mains voltage must not exceed four times per hour.

When the pump is switched on via the mains, it will start after approx. 5 seconds.

If a higher number of starts and stops is desired, use the input for external start/stop when starting/stopping the pump.

When the pump is switched on via an external on/off switch, it will start immediately.

5.2.9 Connections

Note

If no external on/off switch is connected, connect terminals 2 and 3 using a short wire.

As a precaution, the wires to be connected to the following connection groups must be separated from each other by reinforced insulation in their entire lengths:

Group 1: Inputs

- start/stop, terminals 2 and 3
- digital input, terminals 1 and 9
- setpoint input, terminals 4, 5 and 6
- sensor input, terminals 7 and 8
- GENIbus, terminals B, Y and A

All inputs (group 1) are internally separated from the mains-conducting parts by reinforced insulation and galvanically separated from other circuits.

All control terminals are supplied with protective extra-low voltage (PELV), thus ensuring protection against electric shock.

Group 2: Output (relay signal, terminals NC, C, NO)

The output (group 2) is galvanically separated from other circuits. Therefore, the supply voltage or protective extra-low voltage can be connected to the output as desired.

Group 3: Mains supply (terminals N, PE, L)

Group 4: Communication cable (8-pin male socket) - only TPED

The communication cable is connected to the socket in group 4. The cable ensures communication between the two pumps, whether one or two pressure sensors are connected. See section [5.7 Communication cable for TPED pumps](#).

The selector switch in group 4 enables changeover between the operating modes "alternating operation" and "standby operation". See the description in section [6.2.1 Additional operating modes - TPED pumps](#).

TM02 0827 2107

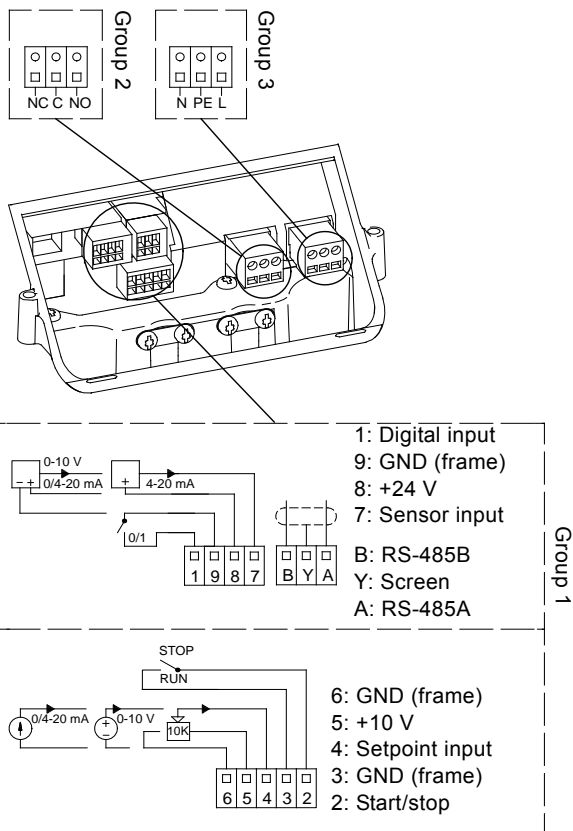

Fig. 4 Connection terminals TPE Series 2000

TM02 0795 0904

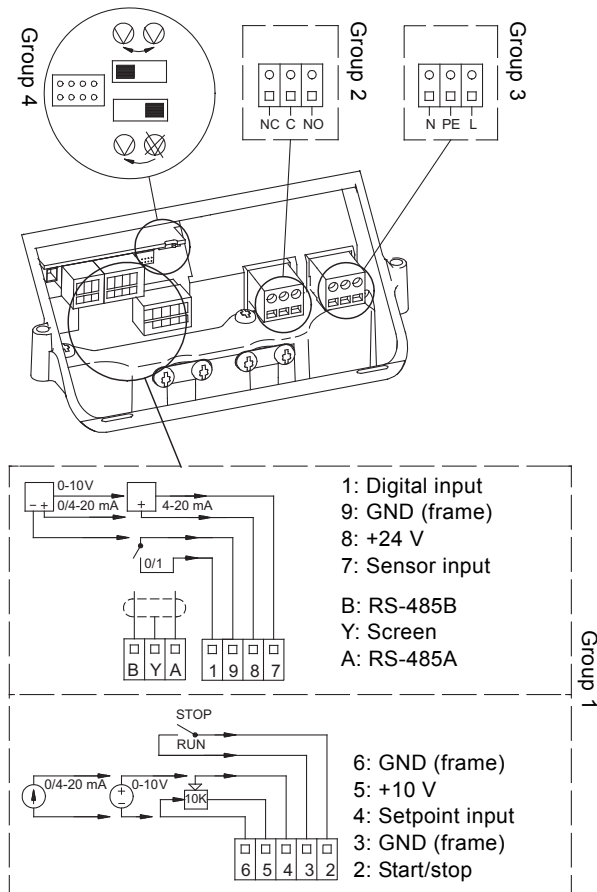

Fig. 5 Connection terminals TPED Series 2000

TM02 6009 0703

A galvanic separation must fulfil the requirements for reinforced insulation including creepage distances and clearances specified in EN 60335.

5.3 Electrical connection - three-phase pumps up to 7.5 kW



Warning

The user or the installer is responsible for the installation of correct earthing and protection according to local standards. All operations must be carried out by qualified staff.



Warning

Never make any connections in the pump terminal box unless all electric supply circuits have been switched off for at least 5 minutes.

Note for instance that the signal relay may be connected to an external supply which is still connected when the mains supply is disconnected.



The above warning is indicated on the motor terminal box by this yellow label.

5.3.1 Preparation

Before connecting the E-pump to the mains, take the issues illustrated in the figure below into consideration.

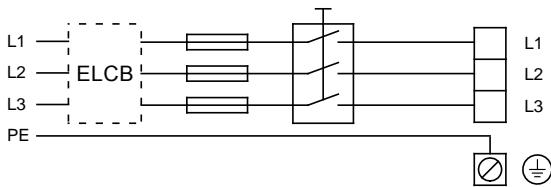

TM00 9270 4696

Fig. 6 Mains-connected pump with mains switch, backup fuses, additional protection and protective earthing

5.3.2 Protection against electric shock - indirect contact



Warning

The pump must be earthed in accordance with local regulations.

As the leakage current of 4 - 7.5 kW motors is greater than 3.5 mA, take extra precautions when earthing these motors.

EN 50178 and BS 7671 specify the following precautions when the leakage current is greater than 3.5 mA:

- The pump must be stationary and installed permanently.
- The pump must be permanently connected to the power supply.
- The earth connection must be carried out as duplicate conductors.

Protective earth conductors must always have a yellow/green (PE) or yellow/green/blue (PEN) colour marking.

5.3.3 Backup fuses

For recommended fuse sizes, see section [20.1 Supply voltage](#).

5.3.4 Additional protection

If the pump is connected to an electric installation where an earth leakage circuit breaker (ELCB) is used as additional protection, the circuit breaker must be of a type marked with the following symbols:

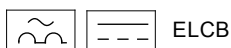

ELCB

This circuit breaker is type B.

The total leakage current of all the electrical equipment in the installation must be taken into account.

The leakage current of the motor in normal operation can be seen in section [21.3 Leakage current](#).

During start and at asymmetrical supply systems, the leakage current can be higher than normal and may cause the ELCB to trip.

5.3.5 Motor protection

The pump requires no external motor protection. The motor incorporates thermal protection against slow overloading and blocking (IEC 34-11, TP 211).

5.3.6 Protection against mains voltage transients

The pump is protected against voltage transients by built-in varistors between the phases and between phases and earth.

5.3.7 Supply voltage and mains

3 x 380-480 V - 10 %/+ 10 %, 50/60 Hz, PE.

The supply voltage and frequency are marked on the pump nameplate. Make sure that the pump is suitable for the power supply of the installation site.

The wires in the terminal box must be as short as possible. Excepted from this is the protective earth conductor which must be so long that it is the last one to be disconnected in case the cable is inadvertently pulled out of the cable entry.

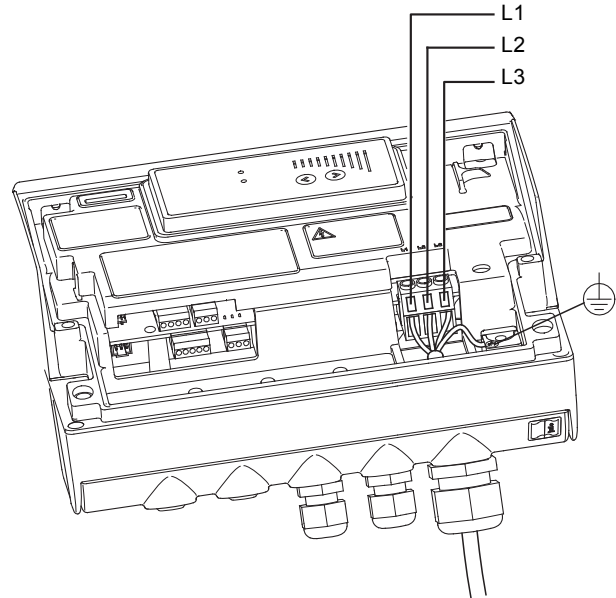

TM03 8600 2007

Fig. 7 Mains connection

Cable glands

Cable glands comply with EN 50626.

- 2 x M16 cable gland, cable diameter $\varnothing 4\text{-}\varnothing 10$
- 1 x M20 cable gland, cable diameter $\varnothing 9\text{-}\varnothing 17$
- 2 x M16 knock-out cable entries.



Warning

If the supply cable is damaged, it must be replaced by qualified staff.

Grid types

Three-phase E-pumps can be connected to all grid types.



Warning

Do not connect three-phase E-pumps to a mains supply with a voltage between phase and earth of more than 440 V.

5.3.8 Start/stop of pump

Caution The number of starts and stops via the mains voltage must not exceed four times per hour.

When the pump is switched on via the mains, it will start after approx. 5 seconds.

If a higher number of starts and stops is desired, use the input for external start/stop when starting/stopping the pump.

When the pump is switched on via an external on/off switch, it will start immediately.

Automatic restart

Note If a pump set up for automatic restart is stopped due to a fault, it will restart automatically when the fault has disappeared.

However, automatic restart only applies to fault types set up to automatic restart. These faults could typically be one of these faults:

- temporary overload
- fault in the power supply.

5.3.9 Connections

Note If no external on/off switch is connected, connect terminals 2 and 3 using a short wire.

As a precaution, the wires to be connected to the following connection groups must be separated from each other by reinforced insulation in their entire lengths:

Group 1: Inputs

- start/stop, terminals 2 and 3
- digital input, terminals 1 and 9
- setpoint input, terminals 4, 5 and 6
- sensor input, terminals 7 and 8
- GENibus, terminals B, Y and A

All inputs (group 1) are internally separated from the mains-conducting parts by reinforced insulation and galvanically separated from other circuits.

All control terminals are supplied with protective extra-low voltage (PELV), thus ensuring protection against electric shock.

Group 2: Output (relay signal, terminals NC, C, NO)

The output (group 2) is galvanically separated from other circuits. Therefore, the supply voltage or protective extra-low voltage can be connected to the output as desired.

Group 3: Mains supply (terminals N, PE, L)

Group 4: Communication cable (8-pin male socket) - only TPED

The communication cable is connected to the socket in group 4. The cable ensures communication between the two pumps, whether one or two pressure sensors are connected. See section [5.7 Communication cable for TPED pumps](#).

The selector switch in group 4 enables changeover between the operating modes "alternating operation" and "standby operation". See the description in section [6.2.1 Additional operating modes - TPED pumps](#).

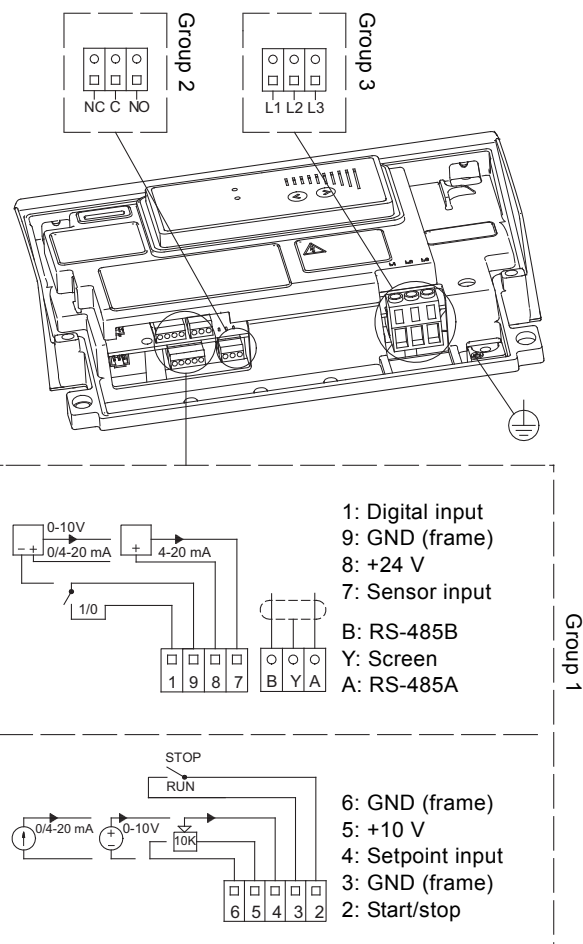

Fig. 8 Connection terminals TPE Series 2000

TM02 84114 5103

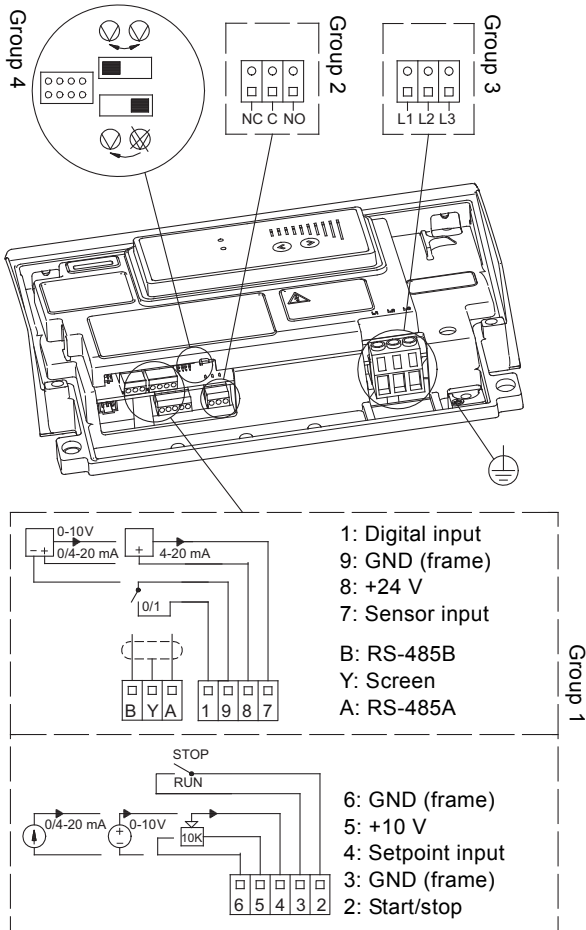

Fig. 9 Connection terminals TPED Series 2000

A galvanic separation must fulfil the requirements for reinforced insulation including creepage distances and clearances specified in EN 60335.

5.4 Electrical connection - three-phase pumps, 11-22 kW

Warning
 The user or the installer is responsible for the installation of correct earthing and protection according to local standards. All operations must be carried out by qualified staff.

Warning
 Never make any connections in the pump terminal box unless all electric supply circuits have been switched off for at least 5 minutes.
 Note for instance that the signal relay may be connected to an external supply which is still connected when the mains supply is disconnected.

Warning
 The surface of the terminal box may be above 70 °C when the pump is operating.

5.4.1 Preparation

Before connecting the E-pump to the mains, take the issues illustrated in the figure below into consideration.

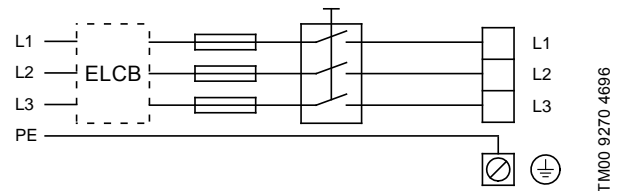

Fig. 10 Mains-connected pump with mains switch, backup fuses, additional protection and protective earthing

5.4.2 Protection against electric shock - indirect contact

Warning
 The pump must be earthed in accordance with local regulations.
 As the leakage current of 11-22 kW motors is greater than 10 mA, take extra precautions when earthing these motors.

EN 61800-5-1 specifies that the pump must be stationary and installed permanently when the leakage current is greater than 10 mA.

One of the following requirements must be fulfilled:

- A single protective earth conductor having a cross-sectional area of minimum 10 mm².

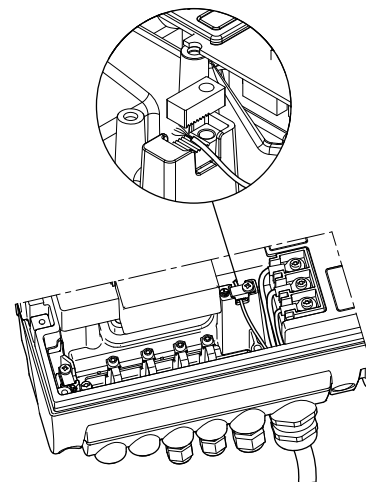

Fig. 11 Connection of a single protective earth conductor using one of the conductors of a 4-core mains cable (with cross-sectional area of minimum 10 mm²)

- Two protective earth conductors of the same cross-sectional area as the mains conductors, with one conductor connected to an additional earth terminal in the terminal box.

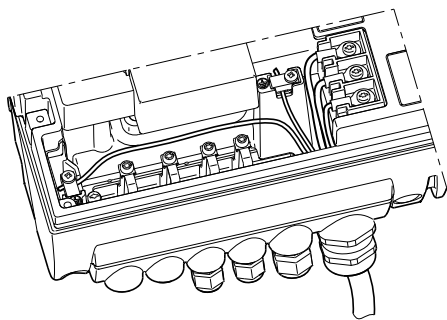

Fig. 12 Connection of two protective earth conductors using two of the conductors of a 5-core mains cable

Protective earth conductors must always have a yellow/green (PE) or yellow/green/blue (PEN) colour marking.

5.4.3 Backup fuses

For recommended fuse sizes, see section [20.1 Supply voltage](#).

5.4.4 Additional protection

If the pump is connected to an electric installation where an earth leakage circuit breaker (ELCB) is used as additional protection, the circuit breaker must be of a type marked with the following symbols:

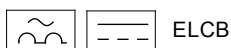

This circuit breaker is type B.

The total leakage current of all the electrical equipment in the installation must be taken into account.

The leakage current of the motor in normal operation can be seen in section [22.3 Leakage current](#).

During start and at asymmetrical supply systems, the leakage current can be higher than normal and may cause the ELCB to trip.

5.4.5 Motor protection

The pump requires no external motor protection. The motor incorporates thermal protection against slow overloading and blocking (IEC 34-11, TP 211).

5.4.6 Protection against mains voltage transients

The pump is protected against mains voltage transients in accordance with EN 61800-3 and is capable of withstanding a VDE 0160 pulse.

The pump has a replaceable varistor which is part of the transient protection.

Over time this varistor will be worn and need to be replaced.

When the time for replacement has come, the R100 and PC Tool E-products will indicate this as a warning. See section [19. Maintenance and service](#).

5.4.7 Supply voltage and mains

3 x 380-480 V - 10 %/+ 10 %, 50/60 Hz, PE.

The supply voltage and frequency are marked on the pump nameplate. Make sure that the motor is suitable for the power supply of the installation site.

The wires in the terminal box must be as short as possible.

Excepted from this is the protective earth conductor which must be so long that it is the last one to be disconnected in case the cable is inadvertently pulled out of the cable entry.

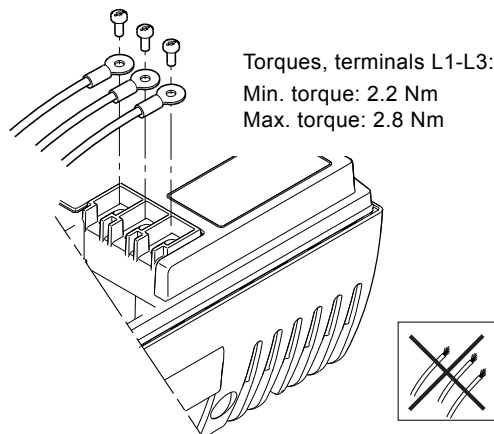

Fig. 13 Mains connection

Cable glands

Cable glands comply with EN 50626.

- 1 x M40 cable gland, cable diameter $\varnothing 16$ - $\varnothing 28$
- 1 x M20 cable gland, cable diameter $\varnothing 9$ - $\varnothing 17$
- 2 x M16 cable gland, cable diameter $\varnothing 4$ - $\varnothing 10$
- 2 x M16 knock-out cable entries.



Warning

If the supply cable is damaged, it must be replaced by qualified staff.

Grid types

Three-phase E-pumps can be connected to all grid types.



Warning

Do not connect three-phase E-pumps to a mains supply with a voltage between phase and earth of more than 440 V.

5.4.8 Start/stop of pump

Caution

The number of starts and stops via the mains voltage must not exceed four times per hour.

When the pump is switched on via the mains, it will start after approx. 5 seconds.

If a higher number of starts and stops is desired, use the input for external start/stop when starting/stopping the pump.

When the pump is switched on via an external on/off switch, it will start immediately.

5.4.9 Connections

Note

If no external on/off switch is connected, connect terminals 2 and 3 using a short wire.

As a precaution, the wires to be connected to the following connection groups must be separated from each other by reinforced insulation in their entire lengths:

Group 1: Inputs

- start/stop, terminals 2 and 3
- digital input, terminals 1 and 9
- setpoint input, terminals 4, 5 and 6
- sensor input, terminals 7 and 8
- GENibus, terminals B, Y and A

All inputs (group 1) are internally separated from the mains-conducting parts by reinforced insulation and galvanically separated from other circuits.

All control terminals are supplied with protective extra-low voltage (PELV), thus ensuring protection against electric shock.

Group 2: Output (relay signal, terminals NC, C, NO)

The output (group 2) is galvanically separated from other circuits. Therefore, the supply voltage or protective extra-low voltage can be connected to the output as desired.

Group 3: Mains supply (terminals L1, L2, L3)

Group 4: Communication cable (8-pin male socket) - only TPED

The communication cable is connected to the socket in group 4. The cable ensures communication between the two pumps, whether one or two pressure sensors are connected. See section 5.7 *Communication cable for TPED pumps*.

The selector switch in group 4 enables changeover between the operating modes "alternating operation" and "standby operation". See the description in section 6.2.1 *Additional operating modes - TPED pumps*.

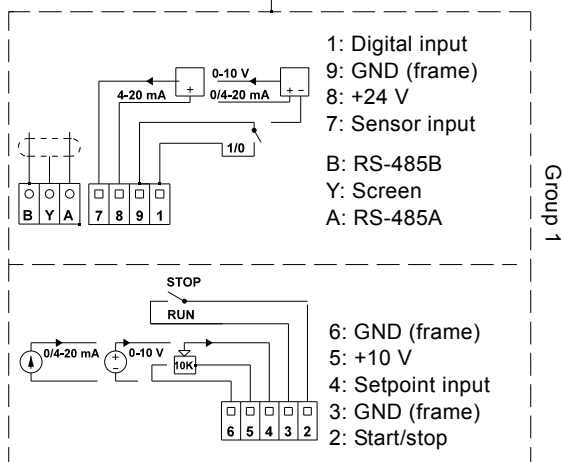
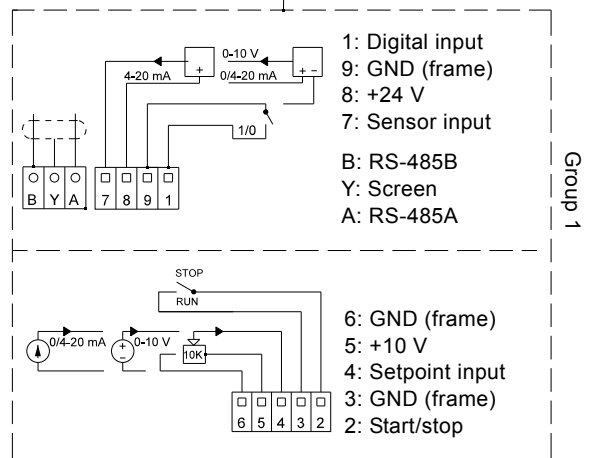
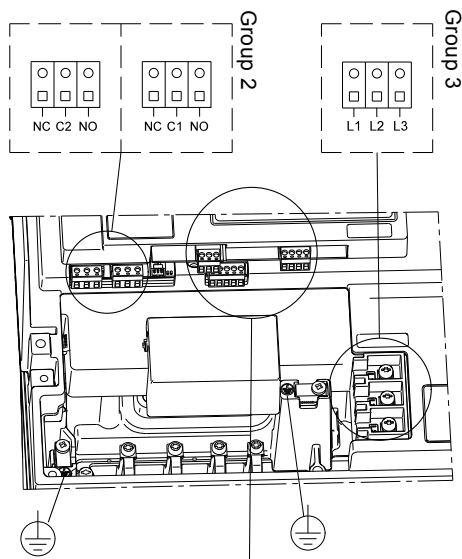
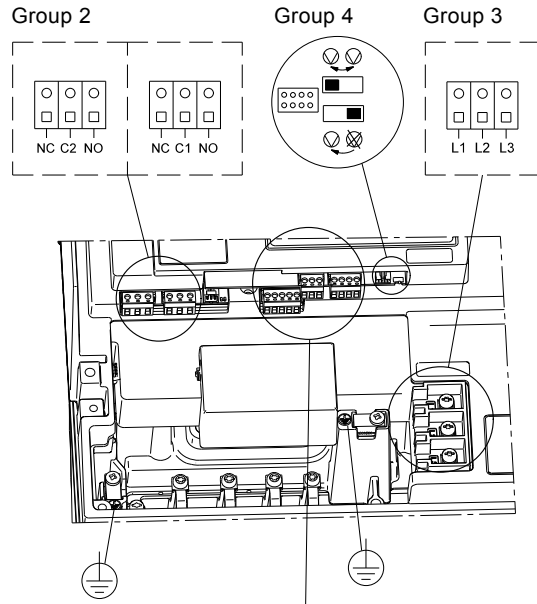

Fig. 15 Connection terminals TPED Series 2000

A galvanic separation must fulfil the requirements for reinforced insulation including creepage distances and clearances specified in EN 61800-5-1.

Fig. 14 Connection terminals TPE Series 2000

TM03 9134 3407

TM03 8608 2007

5.5 Signal cables

- Use screened cables with a cross-sectional area of minimum 0.5 mm² and maximum 1.5 mm² for external on/off switch, digital input, setpoint and sensor signals.
- Connect the screens of the cables to frame at both ends with good frame connection. The screens must be as close as possible to the terminals. See fig. 16.

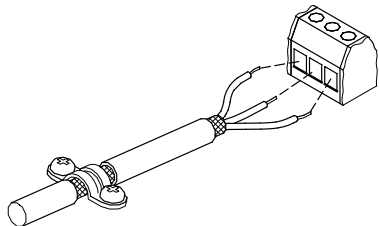

TM02 1325 0901

Fig. 16 Stripped cable with screen and wire connection

- Always tighten screws for frame connections whether a cable is fitted or not.
- Make the wires in the pump terminal box as short as possible.

5.6 Bus connection cable

5.6.1 New installations

For the bus connection, use a screened 3-core cable with a cross-sectional area of minimum 0.2 mm² and maximum 1.5 mm².

- If the pump is connected to a unit with a cable clamp which is identical to the one on the pump, connect the screen to this cable clamp.
- If the unit has no cable clamp as shown in fig. 17, leave the screen unconnected at this end.

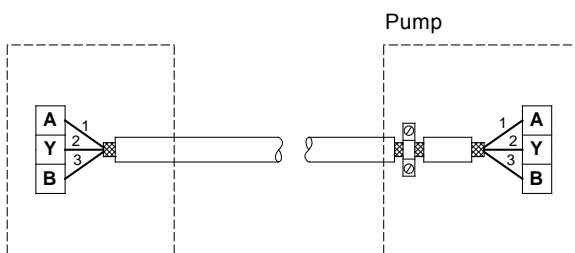

TM02 8841 0904

Fig. 17 Connection with screened 3-core cable

5.6.2 Replacing an existing pump

- If a screened 2-core cable is used in the existing installation, connect it as shown in fig. 18.

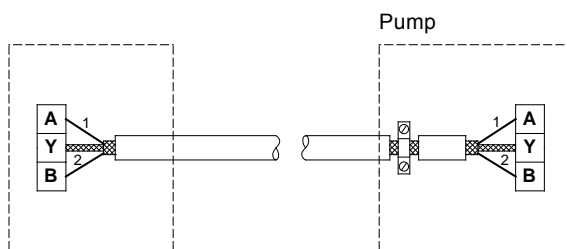

TM02 8842 0904

Fig. 18 Connection with screened 2-core cable

- If a screened 3-core cable is used in the existing installation, follow the instructions in section 5.6.1 *New installations*.

5.7 Communication cable for TPED pumps

The communication cable is connected between the two terminal boxes. The screen of the cable is connected to the frame at both ends with a good frame connection.

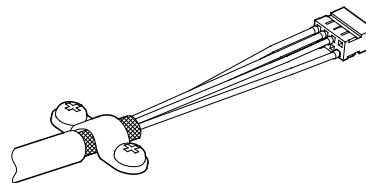

TM02 5991 4702

Fig. 19 Communication cable

The communication cable has a master end and a slave end as shown in fig. 20.

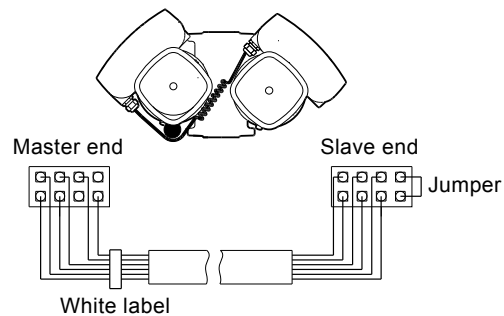

TM04 5497 3309

Fig. 20 Master end and slave end

On pumps with factory-fitted sensor, the master end and the sensor are connected to the same terminal box.

When the power supply to the two pumps has been switched off for 40 seconds and switched on again, the pump connected to the master end will start up first.

5.7.1 Connection of two sensors

The sensor signal is copied to the other pump through the red wire of the communication cable.

If, optionally, two sensors are connected (one sensor to each terminal box), cut the red wire. See fig. 21.

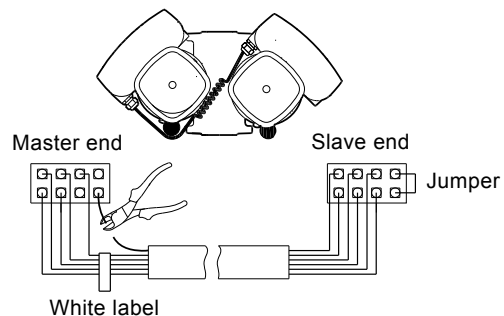

TM04 5495 3309

Fig. 21 Elimination of copied sensor signal

5.7.2 Elimination of alternating operation and standby operation

If alternating operation and standby operation are not desired, but the copied sensor signal (one sensor signal to two pumps) is desired, cut the green wire. See fig. 22.

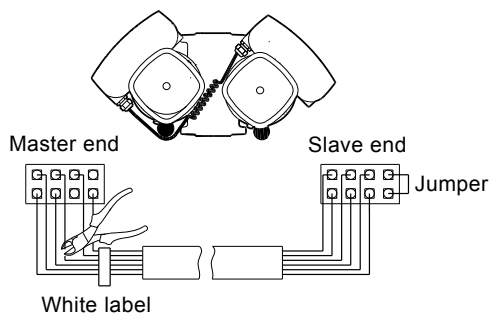

Fig. 22 Elimination of alternating operation and standby operation

TM04 5496 3309

5.7.3 Elimination of TPED function

If alternating operation and standby operation as well as the copied sensor signal are not desired, remove the communication cable completely.

6. Modes

Grundfos E-pumps are set and controlled according to operating and control modes.

6.1 Overview of modes

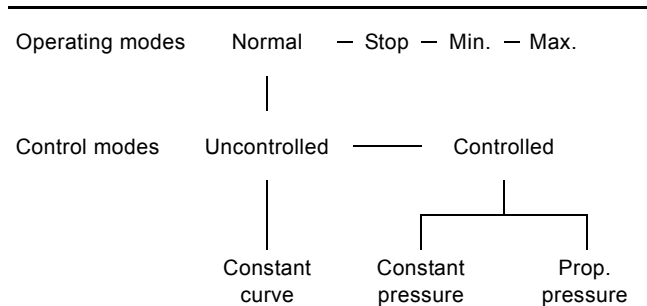

6.2 Operating mode

When the operating mode is set to Normal, the control mode can be set to controlled or uncontrolled. See section 6.3 Control mode.

The other operating modes that can be selected are Stop, Min. or Max.

- Stop: The pump has been stopped.
- Min.: The pump is operating at its minimum speed.
- Max.: The pump is operating at its maximum speed.

Figure 23 is a schematic illustration of min. and max. curves.

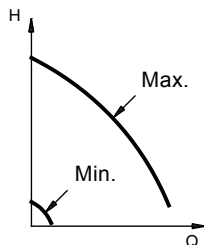

Fig. 23 Min. and max. curves

TM00 5547 0995

The max. curve can for instance be used in connection with the venting procedure during installation.

The min. curve can be used in periods in which a minimum flow is required.

If the power supply to the pump is disconnected, the mode setting will be stored.

The remote control R100 offers additional possibilities of setting and status displays. See section 9. Setting by means of R100.

6.2.1 Additional operating modes - TPED pumps

The TPED pumps offer the following additional operating modes:

- **Alternating operation**
Pump operation alternates every 24 hours. If the duty pump stops due to a fault, the other pump will start.
- **Standby operation**
One pump is operating continuously. In order to prevent seizing-up, the other pump is started for 10 seconds every 24 hours. If the duty pump stops due to a fault, the other pump will start.

Select the operating mode by means of the selector switch in the terminal box. See figures 5, 9 and 15.

The selector switch enables changeover between the operating modes "alternating operation" (left position) and "standby operation" (right position).

The switches in the two terminal boxes of a twin-head pump must be set to the same position. If the switches are positioned differently, the pump will be in standby operation.

Twin-head pumps can be set and operated in the same way as single-head pumps. The duty pump uses its setpoint setting, whether it is made by means of the control panel, via the R100 or via bus.

Note Both pumps should be set to the same setpoint and control mode. Different settings will result in different operation when changing between the two pumps.

If the power supply to the pump is disconnected, the pump setting will be stored.

The remote control R100 offers additional possibilities of setting and status displays. See section 9. Setting by means of R100.

6.3 Control mode

The pump can be set to two primary control modes, i.e.

- proportional pressure
- constant pressure.

Furthermore, the pump can be set to constant curve.

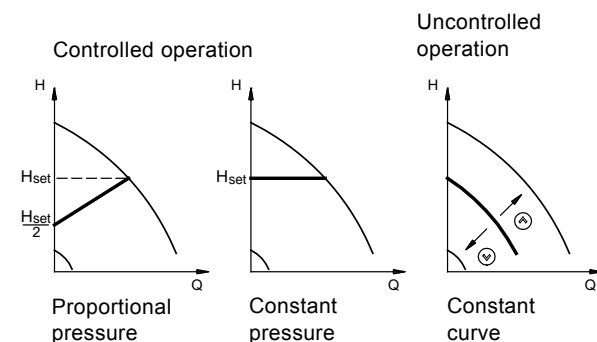

Fig. 24 Controlled and uncontrolled operation

TM00 7630 3604

Proportional-pressure control

The head is reduced at falling water demand and increased at rising water demand. See fig. 24.

Constant-pressure control



The pump maintains a constant pressure, irrespective of water demand. See fig. 24.

Constant curve mode

The pump is not controlled. The curve can be set within the range from min. curve to max. curve. See fig. 24.

The pumps have been factory-set to proportional pressure. See section 6.4 Factory setting. In most cases, this is the optimum control mode, and at the same time it consumes the least energy.

6.3.1 Guide to the selection of control mode based on system type

System type	System description	Select this control mode
Relatively big pressure losses in the boiler, chiller or heat exchanger circuit and the pipes.	1. Two-pipe heating systems with thermostatic valves <ul style="list-style-type: none"> • with a dimensioned head higher than 4 metres • very long distribution pipes • strongly throttled pipe balancing valves • differential pressure regulators • big pressure losses in those parts of the system through which the total quantity of water flows (e.g. boiler, chiller, heat exchanger and pipes up to the first branching). 	Proportional pressure 
	2. Primary circuit pumps in systems with big pressure losses in the primary circuit.	
Relatively small pressure losses in the boiler, chiller or heat exchanger circuit and the pipes.	1. Two-pipe heating or cooling systems with thermostatic valves <ul style="list-style-type: none"> • with a dimensioned head lower than 2 metres • dimensioned for natural circulation • with small head losses in those parts of the system through which the total quantity of water flows (e.g. boiler, chiller, heat exchanger and pipes up to the first branching) • modified to a high differential temperature between flow pipe and return pipe (e.g. district heating). 	Constant pressure 
	2. Floor heating systems with thermostatic valves.	
	3. One-pipe heating systems with thermostatic valves or pipe balancing valves.	
	4. Primary circuit pumps in systems with small pressure losses in the primary circuit.	

6.4 Factory setting

TPE pumps

The pumps have been factory-set to proportional pressure.

The head corresponds to 50 % of the maximum head. See the data sheet for the pump.

Many systems will operate satisfactorily with the factory setting, but most systems can be optimized by changing this setting.

In sections [9.1 Menu OPERATION](#) and [9.3 Menu INSTALLATION](#), the factory setting is marked with bold-faced type under each individual display.

TPED pumps

The pumps have been factory-set to proportional pressure and the additional operating mode "alternating operation".

The head corresponds to 50 % of the maximum head. See the data sheet for the pump.

Many systems will operate satisfactorily with the factory setting, but most systems can be optimized by changing this setting.

In sections [9.1 Menu OPERATION](#) and [9.3 Menu INSTALLATION](#), the factory setting is marked with bold-faced type under each individual display.

7. Setting by means of control panel, single-phase pumps



Warning

At high system temperatures, the pump may be so hot that only the buttons should be touched to avoid burns.

The pump control panel, see fig. 25, incorporates the following buttons and indicator lights:

- Buttons, ⬆ and ⬇, for setpoint setting.
- Light fields, yellow, for indication of setpoint.
- Indicator lights, green (operation) and red (fault).

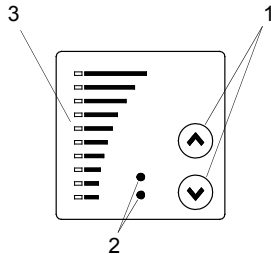

Fig. 25 Control panel, single-phase pumps

Pos.	Description
1	Buttons for setting.
2	Indicator lights for indication of operation and fault.
3	Light fields for indication of head and performance.

Setting of control mode

Description of function, see section 6.3 Control mode.

Change the control mode by pressing the two setting buttons simultaneously for 5 seconds. The control mode will change from constant pressure to proportional pressure or vice versa.

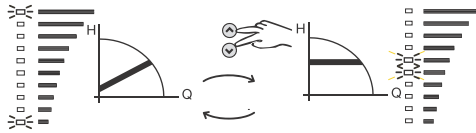

7.1 Setting of head

Set the head by pressing the button ⬆ or ⬇.

The light fields on the control panel will indicate the head set (setpoint). See the following examples.

Proportional pressure

Figure 26 shows that the light fields 5 and 6 are activated, indicating a desired head of 3.4 metres at maximum flow. The setting range lies between 25 % to 90 % of maximum head.

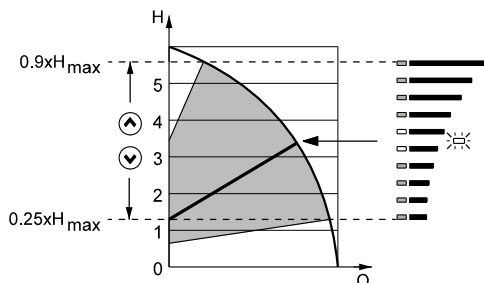

Fig. 26 Pump in control mode proportional pressure

Constant pressure

Figure 27 shows that the light fields 5 and 6 are activated, indicating a desired head of 3.4 metres. The setting range lies between 1/8 (12.5 %) of maximum head and maximum head.

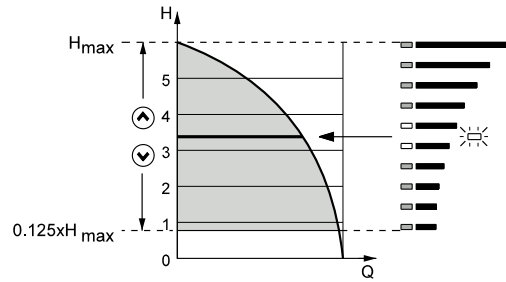

Fig. 27 Pump in control mode constant pressure

7.2 Setting to max. curve duty

Press ⬆ continuously to change to the max. curve of the pump (top light field flashes). See fig. 28.

To change back, press ⬇ continuously until the desired head is indicated.

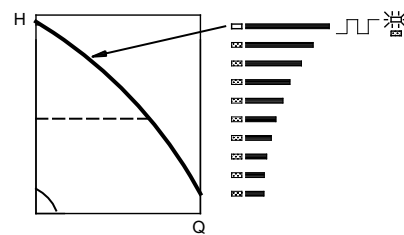

Fig. 28 Max. curve duty

7.3 Setting to min. curve duty

Press ⬇ continuously to change to the min. curve of the pump (bottom light field flashes). See fig. 29.

To change back, press ⬆ continuously until the desired head is indicated.

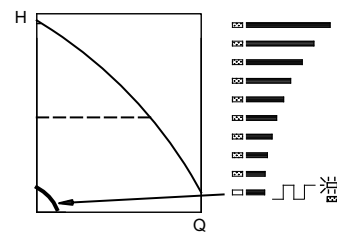

Fig. 29 Min. curve duty

7.4 Start/stop of pump

Start the pump by continuously pressing ⬆ until the desired head is indicated.

Stop the pump by continuously pressing ⬇ until none of the light fields are activated and the green indicator light flashes.

TM00 7600 0304

TM03 9133 3407

TM03 5846 4006

TM03 5845 4006

TM00 7345 1196

TM00 7346 1196

8. Setting by means of control panel, three-phase pumps



Warning

At high system temperatures, the pump may be so hot that only the buttons should be touched to avoid burns.

The pump control panel incorporates the following buttons and indicator lights:

- Buttons, ⬆ and ⬇, for setpoint setting.
- Light fields, yellow, for indication of setpoint.
- Indicator lights, green (operation) and red (fault).

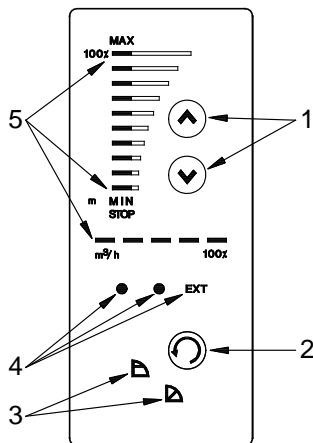

Fig. 30 Control panel, three-phase pumps

Pos.	Description
1 and 2	Buttons for setting.
3 and 5	Light fields for indication of <ul style="list-style-type: none"> • control mode (pos. 3) • head, performance and operating mode (pos. 5).
4	Indicator lights for indication of <ul style="list-style-type: none"> • operation and fault • external control (EXT).

8.1 Setting of control mode

Description of function, see section 6.3 Control mode.

Change the control mode by pressing ⬇ (pos. 2) according to the following cycle:

- constant pressure, ▢
- proportional pressure, ▽



TM03 9061 3307

8.2 Setting of head

Set the head by pressing the button ⬆ or ⬇.

The light fields on the control panel will indicate the head set (setpoint). See the following examples.

Proportional pressure

Figure 31 shows that the light fields 5 and 6 are activated, indicating a desired head of 3.4 metres at maximum flow. The setting range lies between 25 % to 90 % of maximum head.

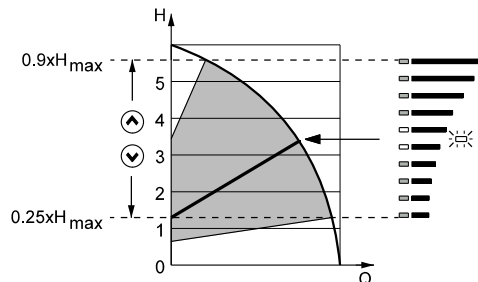

Fig. 31 Pump in control mode proportional pressure

Constant pressure

Figure 32 shows that the light fields 5 and 6 are activated, indicating a desired head of 3.4 metres. The setting range lies between 1/8 (12.5 %) of maximum head and maximum head.

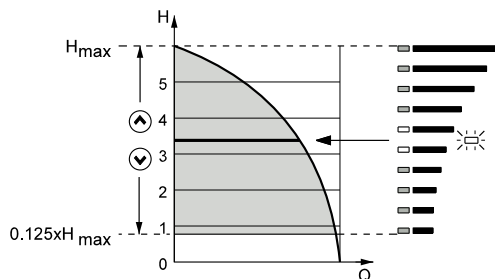

Fig. 32 Pump in control mode constant-pressure

8.3 Setting to max. curve duty

Press ⬆ continuously to change to the max. curve of the pump (MAX illuminates). See fig. 33.

To change back, press ⬇ continuously until the desired head is indicated.

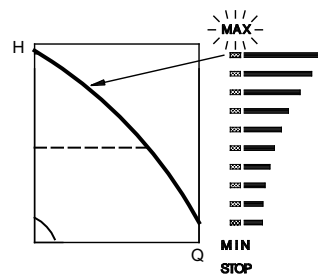

Fig. 33 Max. curve duty

TM03 5846 4006

TM03 5845 4006

TM03 0289 4704

8.4 Setting to min. curve duty

Press \downarrow continuously to change to the min. curve of the pump (MIN illuminates). See fig. 34.

To change back, press \uparrow continuously until the desired head is indicated.

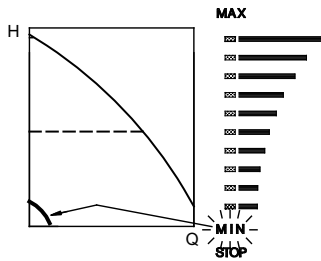

Fig. 34 Min. curve duty

8.5 Start/stop of pump

Start the pump by continuously pressing \uparrow until the desired head is indicated.

Stop the pump by continuously pressing \downarrow until STOP illuminates and the green indicator light flashes.

TM03 0290 4704

9. Setting by means of R100

The pump is designed for wireless communication with the Grundfos remote control R100.

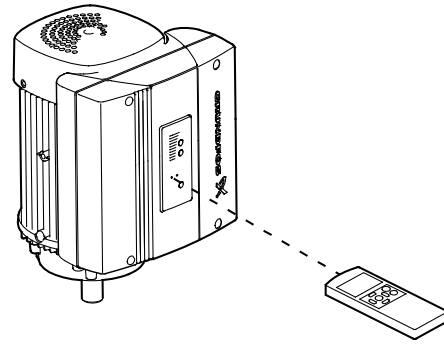

Fig. 35 R100 communicating with the pump via infra-red light

TM03 0141 4104

During communication, the R100 must be pointed at the control panel. When the R100 communicates with the pump, the red indicator light will flash rapidly. Keep pointing the R100 at the control panel until the red LED diode stops flashing.

The R100 offers setting and status displays for the pump.

The displays are divided into four parallel menus, fig. 36:

0. GENERAL (see operating instructions for the R100)

1. OPERATION

2. STATUS

3. INSTALLATION

The figure above each individual display in fig. 36 refers to the section in which the display is described.

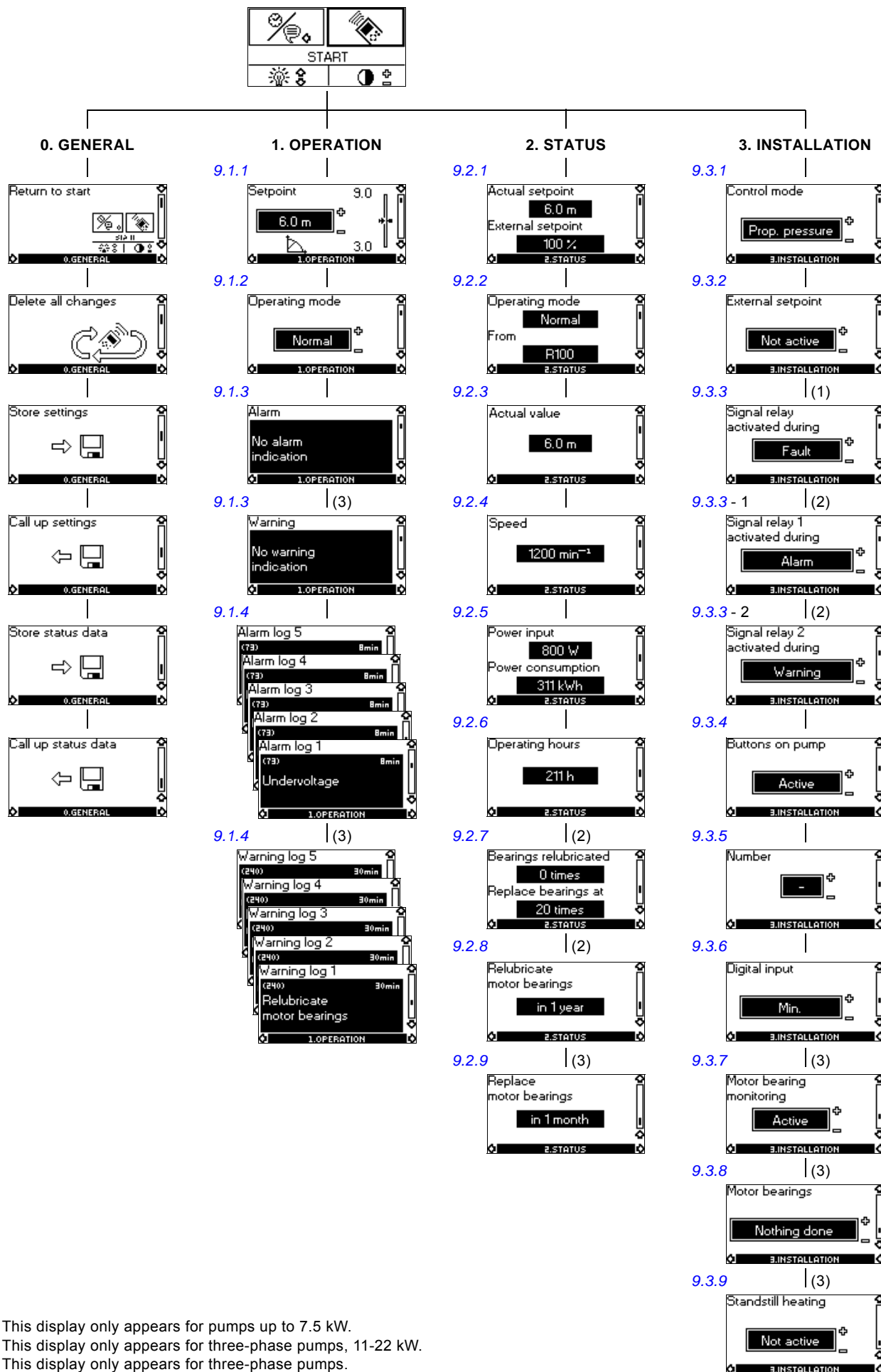

(1): This display only appears for pumps up to 7.5 kW.
 (2): This display only appears for three-phase pumps, 11-22 kW.
 (3): This display only appears for three-phase pumps.

Fig. 36 Menu overview

9.1 Menu OPERATION

The first display in this menu is this:

9.1.1 Setpoint

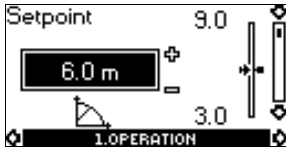

- ▶ Setpoint set
- Actual setpoint
- Actual value

Set the desired setpoint in [m] in this display.

In control mode proportional pressure, the setting range is from 1/4 to 3/4 of maximum head.

In control mode constant pressure, the setting range is from 1/8 of maximum head to maximum head.

In control mode constant curve, the setpoint is set in % of the maximum curve. The curve can be set within the range from min. curve to max. curve.

Select one of the following operating modes:

- Stop
- Min. (min. curve)
- Max. (max. curve).

If the pump is connected to an external setpoint signal, the value in this display will be the maximum value of the external setpoint signal. See section [13. External setpoint signal](#).

Setpoint and external signal

The setpoint cannot be set if the pump is controlled via external signals (Stop, Min. curve or Max. curve). The R100 will give this warning: External control!

Check if the pump is stopped via terminals 2-3 (open circuit) or set to min. or max. via terminals 1-3 (closed circuit).

See section [11. Priority of settings](#).

Setpoint and bus communication

The setpoint cannot be set either if the pump is controlled from an external control system via bus communication. The R100 will give this warning: Bus control!

To override bus communication, disconnect the bus connection.

See section [11. Priority of settings](#).

9.1.2 Operating mode

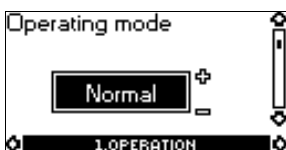

Select one of the following operating modes:

- **Normal** (duty)
- Stop
- Min.
- Max.

The operating modes can be selected without changing the setpoint setting.

9.1.3 Fault indications

In E-pumps, faults may result in two types of indication: alarm or warning.

An alarm fault will activate an alarm indication in the R100 and cause the pump to change operating mode, typically to stop. However, for some faults resulting in alarm, the pump is set to continue operating even if there is an alarm.

A warning fault will activate a warning indication in the R100, but the pump will not change operating or control mode.

Note The indication "Warning" only applies to three-phase pumps.

Alarm

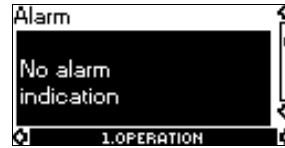

In case of alarm, the cause will appear in this display.

Possible causes:

- No alarm indication
- Too high motor temperature
- Undervoltage
- Mains voltage asymmetry (11-22 kW)
- Overvoltage
- Too many restarts (after faults)
- Overload
- Underload (11-22 kW)
- Sensor signal outside signal range
- Setpoint signal outside signal range
- External fault
- Other fault.

If the pump has been set up to manual restart, an alarm indication can be reset in this display if the cause of the fault has disappeared.

Warning (only three-phase pumps)

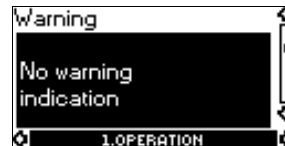

In case of warning, the cause will appear in this display.

Possible causes:

- No warning indication
- Sensor signal outside signal range
- Relubricate motor bearings (only 11-22 kW). See section [19.2 Relubrication of motor bearings](#).
- Replace motor bearings, see section [19.3 Replacement of motor bearings](#)
- Replace varistor (only 11-22 kW). See section [19.4 Replacement of varistor \(only 11-22 kW\)](#).

A warning indication will disappear automatically once the fault has been remedied.

9.1.4 Fault log

For both fault types, alarm and warning, the R100 has a log function.

Alarm log

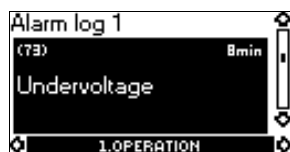

In case of alarm faults, the last five alarm indications will appear in the alarm log. "Alarm log 1" shows the latest fault, "Alarm log 2" shows the latest fault but one, etc.

The example above gives this information:

- the alarm indication Undervoltage
- the fault code (73)
- the number of minutes the pump has been connected to the power supply after the fault occurred, 8 min.

Warning log (only three-phase pumps)



In case of warning faults, the last five warning indications will appear in the warning log. "Warning log 1" shows the latest fault, "Warning log 2" shows the latest fault but one.

The example above gives this information:

- the warning indication "Relubricate motor bearings"
- the fault code (240)
- the number of minutes the pump has been connected to the power supply since the fault occurred, 30 min.

9.2 Menu STATUS

The displays appearing in this menu are status displays only. It is not possible to change or set values.

The displayed values are the values that applied when the last communication between the pump and the R100 took place. If a status value is to be updated, point the R100 at the control panel and press [OK].

If a parameter, e.g. speed, should be called up continuously, press [OK] constantly during the period in which the parameter in question should be monitored.

The tolerance of the displayed value is stated under each display. The tolerances are stated as a guide in % of the maximum values of the parameters.

9.2.1 Actual setpoint

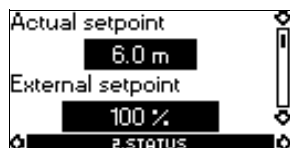

Tolerance: $\pm 2\%$

This display shows the actual setpoint and the external setpoint in % of the range from minimum value to the setpoint set. See section [13. External setpoint signal](#).

9.2.2 Operating mode



This display shows the actual operating mode (Normal (duty), Stop, Min. or Max.). Furthermore, it shows where this operating mode was selected (R100, Pump, Bus or External).

9.2.3 Actual value

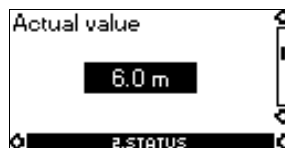

This display shows the value actually measured by a connected sensor.

9.2.4 Speed



Tolerance: $\pm 5\%$

The actual pump speed will appear in this display.

9.2.5 Power input and power consumption

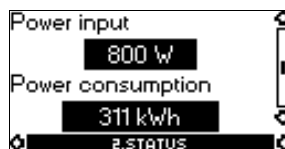

Tolerance: $\pm 10\%$

This display shows the actual pump input power from the mains supply. The power is displayed in W or kW.

The pump power consumption can also be read from this display. The value of power consumption is an accumulated value calculated from the pump's birth and it cannot be reset.

9.2.6 Operating hours



Tolerance: $\pm 2\%$

The value of operating hours is an accumulated value and cannot be reset.

9.2.7 Lubrication status of motor bearings (only 11-22 kW)



This display shows how many times the motor bearings have been relubricated and when to replace the motor bearings.

When the motor bearings have been relubricated, confirm this action in the INSTALLATION menu. See section [9.3.8 Confirming relubrication/replacement of motor bearings \(only three-phase pumps\)](#). When relubrication is confirmed, the figure in the above display will be increased by one.

9.2.8 Time till relubrication of motor bearings (only 11-22 kW)



This display shows when to relubricate the motor bearings. The controller monitors the operating pattern of the pump and calculates the period between bearing relubrications. If the operating pattern changes, the calculated time till relubrication may change as well.

The displayable values are these:

- in 2 years
- in 1 year
- in 6 months
- in 3 months
- in 1 month
- in 1 week
- Now!

9.2.9 Time till replacement of motor bearings (only three-phase pumps)

When the motor bearings have been relubricated, a prescribed number of times stored in the controller, the display in section [9.2.8 Time till relubrication of motor bearings \(only 11-22 kW\)](#) will be replaced by the display below.



This display shows when to replace the motor bearings. The controller monitors the operating pattern of the pump and calculates the period between bearing replacements.

The displayable values are these:

- in 2 years
- in 1 year
- in 6 months
- in 3 months
- in 1 month
- in 1 week
- Now!

9.3 Menu INSTALLATION

9.3.1 Control mode



Select one of the following control modes (see fig. 24):

- **Prop. pressure** (proportional pressure)
- Const. pressure (constant pressure)
- Const. curve (constant curve).

How to set the desired performance, see section [9.1.1 Setpoint](#).

Note If the pump is connected to a bus, the control mode cannot be selected via the R100. See section [14. Bus signal](#).

9.3.2 External setpoint



The input for external setpoint signal can be set to different signal types.

Select one of the following types:

- 0-10 V
- 0-20 mA
- 4-20 mA
- **Not active.**

If "Not active" is selected, the setpoint set by means of the R100 or on the control panel will apply.

If one of the signal types is selected, the actual setpoint is influenced by the signal connected to the external setpoint input. See section [13. External setpoint signal](#).

9.3.3 Signal relay

Pumps up to 7.5 kW have one signal relay. The factory setting of the relay will be Fault.

Pumps of 11-22 kW have two signal relays. Signal relay 1 is factory-set to Alarm and signal relay 2 to Warning.

In one of the displays below, select in which operating situation the signal relay should be activated.

For further information, see section [16. Indicator lights and signal relay](#).

Up to 7.5 kW



- Ready
- **Fault**
- Operation
- Pump running (only three-phase pumps up to 7.5 kW)
- Warning (only three-phase pumps up to 7.5 kW).

11-22 kW



- Ready
- **Alarm**
- Operation
- Pump running
- Warning
- Relubricate.

11-22 kW



- Ready
- Alarm
- Operation
- Pump running
- **Warning**
- Relubricate.

Fault and Alarm cover faults resulting in Alarm. Warning covers faults resulting in Warning.

Note

Relubricate covers only that one individual event. For distinction between alarm and warning, see section [9.1.3 Fault indications](#).

For further information, see section [16. Indicator lights and signal relay](#).

9.3.4 Buttons on pump



The operating buttons  and  on the control panel can be set to these values:

- **Active**
- Not active.

When set to Not active (locked), the buttons do not function. Set the buttons to Not active if the pump should be controlled via an external control system.

9.3.5 Pump number



A number between 1 and 64 can be allocated to the pump. In the case of bus communication, a number must be allocated to each pump.

9.3.6 Digital input



The digital input of the pump (terminal 1, figures [4](#), [8](#) and [14](#)) can be set to different functions.

Select one of the following functions:

- **Min.** (min. curve)
- Max. (max. curve).

The selected function is activated by closing the contact between terminals 1 and 9 (figures [4](#), [8](#) and [14](#)).

See also section [12.2 Digital input](#).

Min.:

When the input is activated, the pump is operating according to the min. curve.

Max.:

When the input is activated, the pump is operating according to the max. curve.

9.3.7 Motor bearing monitoring (only three-phase pumps)



The motor bearing monitoring function can be set to these values:

- **Active**
- Not active.

When the function is set to Active, a counter in the controller will start counting the mileage of the bearings. See section [9.2.7 Lubrication status of motor bearings \(only 11-22 kW\)](#).

The counter will continue counting even if the function is switched to Not active, but a warning will not be given when it is time for relubrication.

Note

When the function is switched to Active again, the accumulated mileage will again be used to calculate the relubrication time.

9.3.8 Confirming relubrication/replacement of motor bearings (only three-phase pumps)



This function can be set to these values:

- Relubricated (only 11-22 kW)
- Replaced
- **Nothing done.**

When the bearing monitoring function is Active, the controller will give a warning indication when the motor bearings are due to be relubricated or replaced. See section [9.1.3 Fault indications](#).

When the motor bearings have been relubricated or replaced, confirm this action in the above display by pressing [OK].

Note

Relubricated cannot be selected for a period of time after confirming relubrication.

9.3.9 Standstill heating (only three-phase pumps)



The standstill heating function can be set to these values:

- Active
- **Not active.**

When the function is set to Active, a low voltage will be applied to the motor windings. The applied voltage will ensure that sufficient heat is generated to avoid condensation in the motor.

10. Setting by means of PC Tool E-products

Special setup requirements differing from the settings available via the R100 require the use of Grundfos PC Tool E-products. This again requires the assistance of a Grundfos service technician or engineer. Contact your local Grundfos company for more information.

11. Priority of settings

The priority of settings depends on two factors:

1. control source
2. settings.

1. Control source

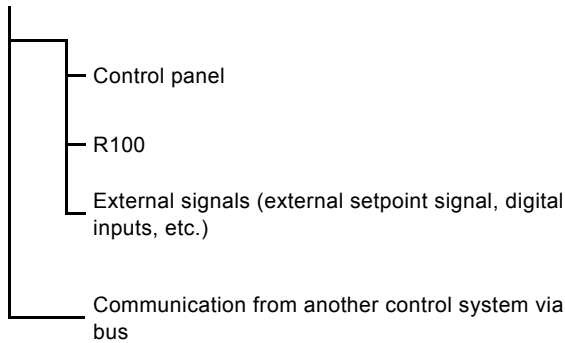

2. Settings

- Operating mode "Stop"
- Operating mode "Max." (max. curve)
- Operating mode "Min." (min. curve)
- Setpoint setting.

An E-pump can be controlled by different control sources at the same time, and each of these sources can be set differently. Consequently, it is necessary to set an order of priority of the control sources and the settings.

Note If two or more settings are activated at the same time, the pump will operate according to the function with the highest priority.

Priority of settings without bus communication

Priority	Control panel or R100	External signals
1	Stop	
2	Max.	
3		Stop
4		Max.
5	Min.	Min.
6	Setpoint setting	Setpoint setting

Example: If the E-pump has been set to operating mode Max. (max. frequency) via an external signal, such as digital input, the control panel or R100 can only set the E-pump to operating mode Stop.

Priority of settings with bus communication

Priority	Control panel or R100	External signals	Bus communication
1	Stop		
2	Max.		
3		Stop	Stop
4			Max.
5			Min.
6			Setpoint setting

Example: If the E-pump is operating according to a setpoint set via bus communication, the control panel or R100 can set the E-pump to operating mode Stop or Max., and the external signal can only set the E-pump to operating mode Stop.

12. External forced-control signals

The pump has inputs for external signals for the forced-control functions:

- Start/stop of pump.
- Digital function.

12.1 Start/stop input

Functional diagram: Start/stop input

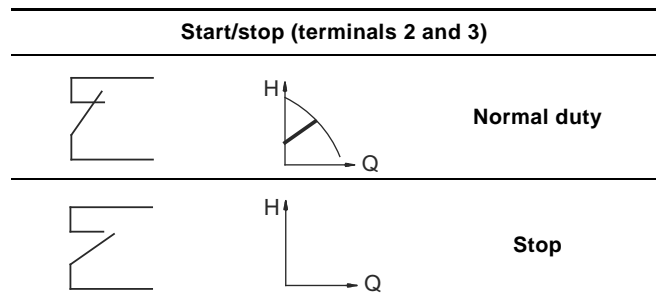

12.2 Digital input

By means of the R100, one of the following functions can be selected for the digital input:

- Min. curve
- Max. curve.

Functional diagram: Input for digital function

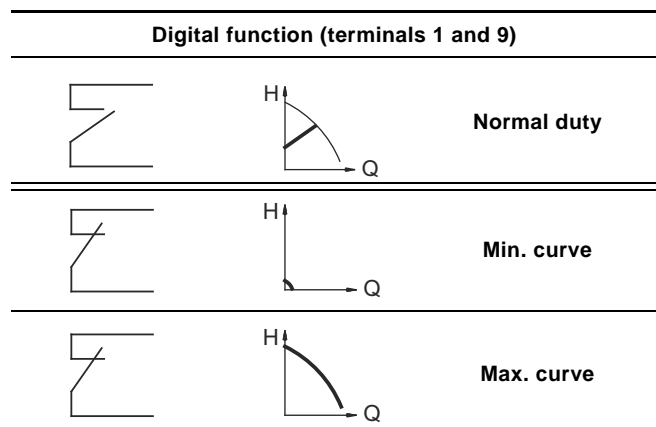

13. External setpoint signal

The setpoint can be remote-set by connecting an analogue signal transmitter to the input for the setpoint signal (terminal 4).

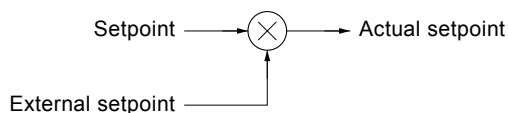

Fig. 37 Actual setpoint as a product (multiplied value) of setpoint and external setpoint

TM03 8601 2007

Select the actual external signal, 0-10 V, 0-20 mA, 4-20 mA, via the R100. See section [9.1.3 Fault indications](#).

Control mode controlled

If control mode controlled, see control hierarchy in section [6.1 Overview of modes](#), is selected by means of the R100, the pump can be controlled to:

- proportional pressure
- constant pressure.

In control mode proportional pressure, the setpoint can be set externally within the range from 25 % of maximum head to the setpoint set on the pump or by means of the R100. See [fig. 38](#).

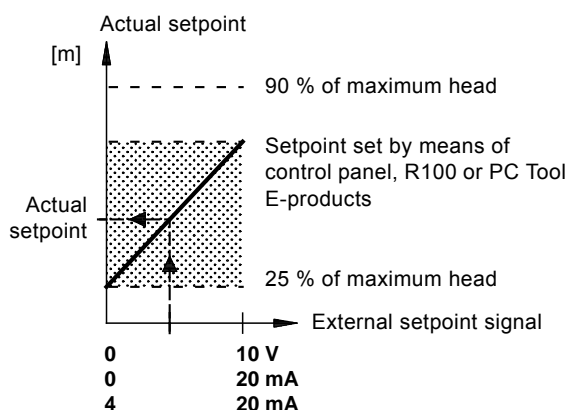

Fig. 38 Relation between the actual setpoint and the external setpoint signal in control mode proportional pressure

TM02 8988 1304

Example: At a maximum head of 12 metres, a setpoint of 6 metres and an external setpoint of 40 %, the actual setpoint will be as follows:

$$H_{\text{actual}} = (H_{\text{set}} - 1/4 H_{\text{max.}}) \times \%_{\text{external setpoint}} + 1/4 H_{\text{max.}}$$

$$= (6 - 12/4) \times 40 \% + 12/4$$

$$= 4.2 \text{ metres}$$

In control mode constant pressure, the setpoint can be set externally within the range from 12.5 % of maximum head to the setpoint set on the pump or by means of the R100. See [fig. 39](#).

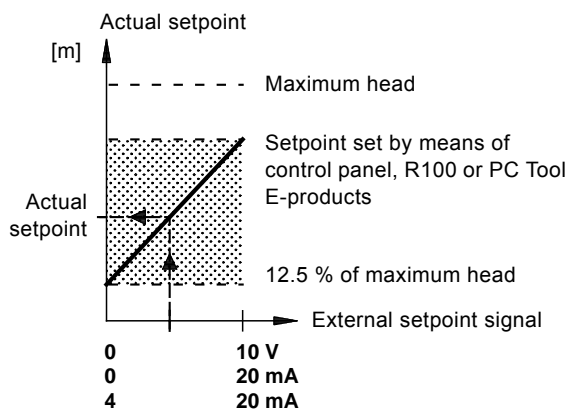

Fig. 39 Relation between the actual setpoint and the external setpoint signal in control mode constant pressure

TM02 8988 1304

Example: At a maximum head of 12 metres, a setpoint of 6 metres and an external setpoint of 80 %, the actual setpoint will be as follows:

$$H_{\text{actual}} = (H_{\text{set}} - 1/8 H_{\text{max.}}) \times \%_{\text{external setpoint}} + 1/8 H_{\text{max.}}$$

$$= (6 - 12/8) \times 80 \% + 12/8$$

$$= 5.1 \text{ metres}$$

Control mode uncontrolled

If control mode uncontrolled, see control hierarchy in section [6.1 Overview of modes](#), is selected by means of the R100, the pump is controlled to a constant curve and can be controlled by any (external) controller.

In control mode constant curve, the setpoint can be set externally within the range from the min. curve to the setpoint set on the pump or by means of the R100. See [fig. 40](#).

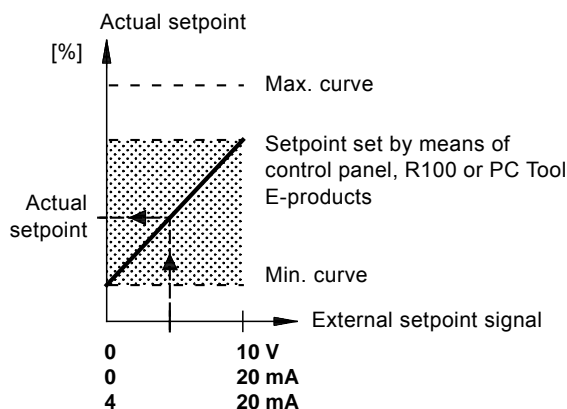

Fig. 40 Relation between the actual setpoint and the external setpoint signal in control mode constant curve

TM02 8988 1304

14. Bus signal

The pump supports serial communication via an RS-485 input. The communication is carried out according to the Grundfos bus protocol, GENibus protocol, and enables connection to a building management system or another external control system.

Operating parameters, such as setpoint, operating mode, etc. can be remote-set via the bus signal. At the same time, the pump can provide status information about important parameters, such as actual value of control parameter, input power, fault indications, etc.

Contact Grundfos for further details.

Note If a bus signal is used, the number of settings available via the R100 will be reduced.

15. Other bus standards

Grundfos offers various bus solutions with communication according to other standards.

Contact Grundfos for further details.

16. Indicator lights and signal relay

The operating condition of the pump is indicated by the green and red indicator lights fitted on the pump control panel and inside the terminal box. See figures 41 and 42.

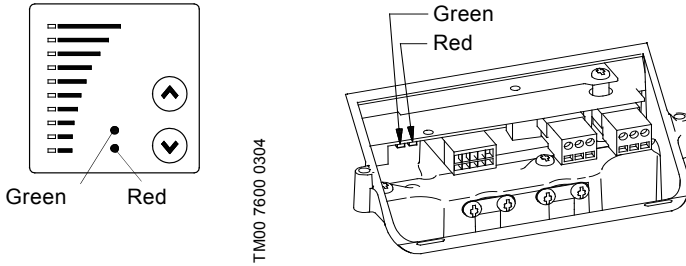

Fig. 41 Position of indicator lights on single-phase pumps

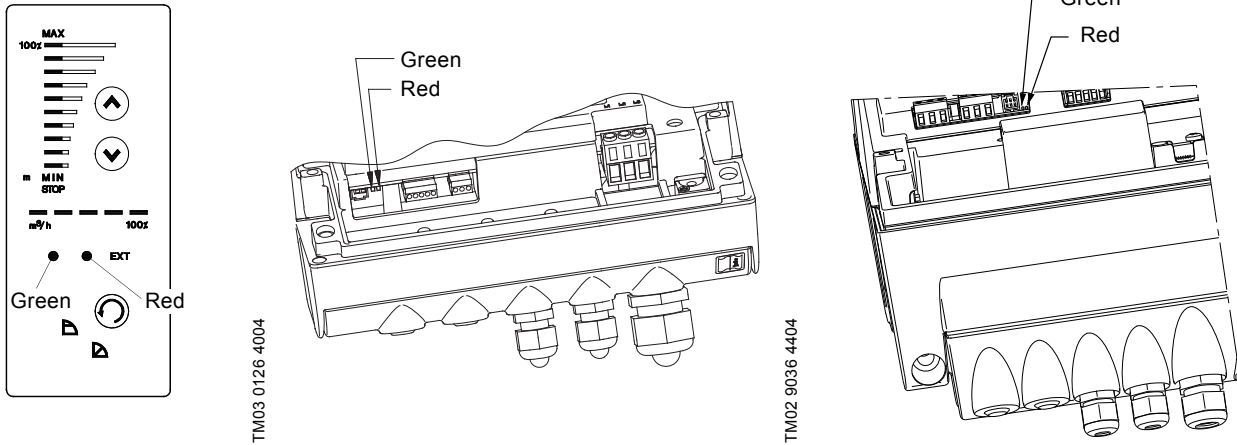

Fig. 42 Position of indicator lights on three-phase pumps

Besides, the pump incorporates an output for a potential-free signal via an internal relay.

For signal relay output values, see section [9.3.3 Signal relay](#).

The functions of the two indicator lights and the signal relay are as shown in the following table:

Indicator lights		Signal relay activated during				Description
Fault (red)	Operation (green)	Fault/Alarm, Warning and Relubricate	Operating	Ready	Pump running	
Off	Off					The power supply has been switched off.
Off	Permanently on					The pump is operating.
Off	Flashing					The pump has been set to stop.
Permanently on	Off					The pump has stopped because of a Fault/Alarm or is running with a Warning or Relubricate indication. If the pump was stopped, restarting will be attempted (it may be necessary to restart the pump by resetting the Fault indication).
Permanently on	Permanently on					The pump is operating, but it has or has had a Fault/Alarm allowing the pump to continue operation or it is operating with a Warning or Relubricate indication. If the cause is "sensor signal outside signal range", the pump will continue operating according to the max. curve and the fault indication cannot be reset until the signal is inside the signal range. If the cause is "setpoint signal outside signal range", the pump will continue operating according to the min. curve and the fault indication cannot be reset until the signal is inside the signal range.
Permanently on	Flashing					The pump has been set to stop, but it has been stopped because of a Fault.

Resetting of fault indication

A fault indication can be reset in one of the following ways:

- Briefly press the button or on the pump. This will not change the setting of the pump.
A fault indication cannot be reset by means of or if the buttons have been locked.
- Switch off the power supply until the indicator lights are off.
- Switch the external start/stop input off and then on again.
- Use the R100. See section [9.1.3 Fault indications](#).

When the R100 communicates with the pump, the red indicator light will flash rapidly.

17. Insulation resistance

Up to 7.5 kW

Caution

Do not measure the insulation resistance of motor windings or an installation incorporating E-pumps using high voltage megging equipment, as this may damage the built-in electronics.

11-22 kW

Caution

Do not measure the insulation resistance of an installation incorporating E-pumps using high voltage megging equipment, as this may damage the built-in electronics.

The motor conductors can be disconnected separately and the insulation resistance of the motor windings can be tested.

18. Emergency operation (only 11-22 kW)

Warning



Never make any connections in the pump terminal box unless all electric supply circuits have been switched off for at least 5 minutes.

Note for instance that the signal relay may be connected to an external supply which is still connected when the mains supply is disconnected.

If the pump has stopped and it does not restart after you have gone through normal remedies, the reason could be a faulty frequency converter. If this is the case, it is possible to establish emergency operation of the pump.

But before you change to emergency operation, we recommend you to check these points:

- Check that the mains supply is OK.
- Check that control signals are working (start/stop signals).
- Check that all alarms have been reset.
- Make a resistance test on the motor windings (disconnect the motor conductors from the terminal box).

If the pump still does not start, the frequency converter is faulty.

To establish emergency operation, proceed as follows:

1. Disconnect the three mains conductors, L1, L2, L3, from the terminal box, but leave the protective earth conductor(s) in position on the PE terminal(s).

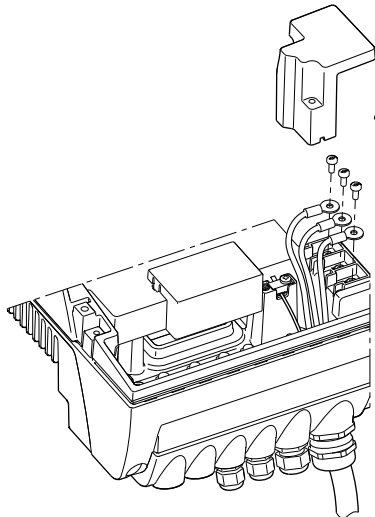

Fig. 43 Disconnecting the mains conductors

TM03 8607 2007

2. Disconnect the motor supply conductors, U/W1, V/U1, W/V1, from the terminal box.

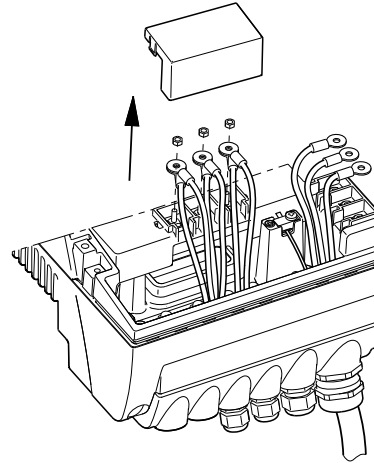

Fig. 44 Disconnecting the motor supply conductors

TM03 9120 3407

3. Connect the conductors as shown in fig. 45.

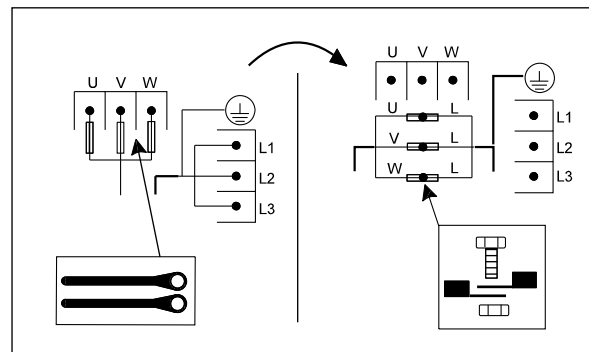

Fig. 45 How to switch an E-pump from normal operation to emergency operation

TM04 0018 4807

Use the screws from the mains terminals and the nuts from the motor terminals.

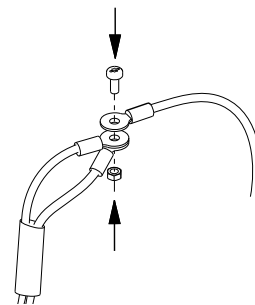

Fig. 46 Connecting the conductors

TM03 9121 3407

4. Insulate the three conductors from each other by means of insulating tape or the like.

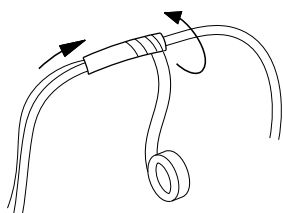

Fig. 47 Insulating the conductors

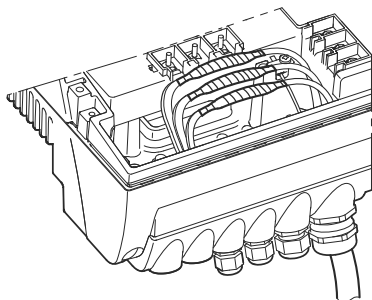

Fig. 48 Insulated conductors

Warning



Do not bypass the frequency converter by connecting the mains conductors to the U, V and W terminals.

This may cause hazardous situations for staff as the high voltage potential of the mains may be transferred to touchable components in the terminal box.

Caution

Check the direction of rotation when starting up after switching to emergency operation.

19. Maintenance and service

19.1 Cleaning of the motor

Keep the motor cooling fins and fan blades clean to ensure sufficient cooling of the motor and electronics.

19.2 Relubrication of motor bearings

Pumps up to 7.5 kW

The motor bearings are of the closed type and greased for life. The bearings cannot be relubricated.

Pumps of 11-22 kW

The motor bearings are of the open type and must be relubricated regularly.

The motor bearings are pre-lubricated on delivery. The built-in bearing monitoring function will give a warning indication on the R100 when the motor bearings are due to be relubricated.

Note

Before relubrication, remove the bottom plug in the motor flange and the plug in the bearing cover to ensure that old and excess grease can escape.

Frame size	Quantity of grease [ml]	
	Drive end	Non-drive end
MGE 160	13	13
MGE 180	15	15

When relubricating the first time, use the double quantity of grease as the lubricating channel is still empty.

The recommended grease type is a polycarbamide-based lubricating grease.

19.3 Replacement of motor bearings

Three-phase motors have built-in bearing monitoring function which will give a warning indication on the R100 when the motor bearings are due to be replaced.

19.4 Replacement of varistor (only 11-22 kW)

The varistor protects the pump against mains voltage transients. If voltage transients occur, the varistor will be worn over time and need to be replaced. The more transients, the more quickly the varistor will be worn. When it is time to replace the varistor, R100 and PC Tool E-products will indicate this as a warning.

A Grundfos technician is required for replacement of the varistor. Contact your local Grundfos company for assistance.

19.5 Service parts and service kits

For further information on service parts and service kits, visit www.grundfos.com, select country, select Grundfos Product Center.

TMO3 9122 3407

TMO3 9123 3407

20. Technical data - single-phase pumps

20.1 Supply voltage

1 x 200-240 V - 10 %/+ 10 %, 50/60 Hz - 2 %/+ 2 %, PE.

Recommended fuse size

Motor sizes up to 1.1 kW: Max. 10 A.

Standard as well as quick-blow or slow-blow fuses may be used.

20.2 Overload protection

The overload protection of the E-motor has the same characteristic as an ordinary motor protector. As an example, the E-motor can stand an overload of 110 % of I_{nom} for 1 min.

20.3 Leakage current

The earth leakage current is less than 3.5 mA.

The leakage currents are measured in accordance with EN 61800-5-1.

20.4 Inputs/outputs

Start/stop

External potential-free switch.

Voltage: 5 VDC.

Current: < 5 mA.

Screened cable: 0.5 - 1.5 mm² / 28-16 AWG.

Digital

External potential-free switch.

Voltage: 5 VDC.

Current: < 5 mA.

Screened cable: 0.5 - 1.5 mm² / 28-16 AWG.

Setpoint signals

- Potentiometer
0-10 VDC, 10 kΩ (via internal voltage supply).
Screened cable: 0.5 - 1.5 mm² / 28-16 AWG.
Maximum cable length: 100 m.
- Voltage signal
0-10 VDC, $R_i > 50$ kΩ.
Tolerance: + 0 %/- 3 % at maximum voltage signal.
Screened cable: 0.5 - 1.5 mm² / 28-16 AWG.
Maximum cable length: 500 m.
- Current signal
DC 0-20 mA/4-20 mA, $R_i = 175$ Ω.
Tolerance: + 0 %/- 3 % at maximum current signal.
Screened cable: 0.5 - 1.5 mm² / 28-16 AWG.
Maximum cable length: 500 m.

Signal relay output

Potential-free changeover contact.

Maximum contact load: 250 VAC, 2 A, $\cos \varphi$ 0.3 - 1.

Minimum contact load: 5 VDC, 10 mA.

Screened cable: 0.5 - 2.5 mm² / 28-12 AWG.

Maximum cable length: 500 m.

Bus input

Grundfos bus protocol, GENIbus protocol, RS-485.

Screened 3-core cable: 0.2 - 1.5 mm² / 28-16 AWG.

Maximum cable length: 500 m.

21. Technical data - three-phase pumps up to 7.5 kW

21.1 Supply voltage

3 x 380-480 V - 10 %/+ 10 %, 50/60 Hz - 2 %/+ 2 %, PE.

Recommended fuse sizes

Motor sizes from 0.55 to 5.5 kW: Max. 16 A.

Motor size 7.5 kW: Max. 32 A.

Standard as well as quick-blow or slow-blow fuses may be used.

21.2 Overload protection

The overload protection of the E-motor has the same characteristic as an ordinary motor protector. As an example, the E-motor can stand an overload of 110 % of I_{nom} for 1 min.

21.3 Leakage current

Motor size [kW]	Leakage current [mA]
0.55 to 3.0 (supply voltage < 460 V)	< 3.5
0.55 to 3.0 (supply voltage > 460 V)	< 5
4.0 - 5.5	< 5
7.5	< 10

The leakage currents are measured in accordance with EN 61800-5-1.

21.4 Inputs/output

Start/stop

External potential-free switch.

Voltage: 5 VDC.

Current: < 5 mA.

Screened cable: 0.5 - 1.5 mm² / 28-16 AWG.

Digital

External potential-free switch.

Voltage: 5 VDC.

Current: < 5 mA.

Screened cable: 0.5 - 1.5 mm² / 28-16 AWG.

Setpoint signals

- Potentiometer
0-10 VDC, 10 kΩ (via internal voltage supply).
Screened cable: 0.5 - 1.5 mm² / 28-16 AWG.
Maximum cable length: 100 m.
- Voltage signal
0-10 VDC, $R_i > 50$ kΩ.
Tolerance: + 0 %/- 3 % at maximum voltage signal.
Screened cable: 0.5 - 1.5 mm² / 28-16 AWG.
Maximum cable length: 500 m.
- Current signal
DC 0-20 mA/4-20 mA, $R_i = 175$ Ω.
Tolerance: + 0 %/- 3 % at maximum current signal.
Screened cable: 0.5 - 1.5 mm² / 28-16 AWG.
Maximum cable length: 500 m.

Signal relay output

Potential-free changeover contact.

Maximum contact load: 250 VAC, 2 A, $\cos \varphi$ 0.3 - 1.

Minimum contact load: 5 VDC, 10 mA.

Screened cable: 0.5 - 2.5 mm² / 28-12 AWG.

Maximum cable length: 500 m.

Bus input

Grundfos bus protocol, GENIbus protocol, RS-485.

Screened 3-core cable: 0.2 - 1.5 mm² / 28-16 AWG.

Maximum cable length: 500 m.

22. Technical data - three-phase pumps, 11-22 kW

22.1 Supply voltage

3 x 380-480 V - 10 %/+ 10 %, 50/60 Hz - 3 %/+ 3 %, PE.

Recommended fuse sizes

Motor size [kW]		Max. [A]
2-pole	4-pole	
11	11	32
15	15	36
18.5	18.5	43
22	22	51

Standard as well as quick-blow or slow-blow fuses may be used.

22.2 Overload protection

The overload protection of the E-motor has the same characteristic as an ordinary motor protector. As an example, the E-motor can stand an overload of 110 % of I_{nom} for 1 min.

22.3 Leakage current

The earth leakage current is greater than 10 mA.

The leakage currents are measured in accordance with EN 61800-5-1.

22.4 Inputs/output

Start/stop

External potential-free switch.

Voltage: 5 VDC.

Current: < 5 mA.

Screened cable: 0.5 - 1.5 mm² / 28-16 AWG.

Digital

External potential-free switch.

Voltage: 5 VDC.

Current: < 5 mA.

Screened cable: 0.5 - 1.5 mm² / 28-16 AWG.

Setpoint signals

- Potentiometer
0-10 VDC, 10 kΩ (via internal voltage supply).
Screened cable: 0.5 - 1.5 mm² / 28-16 AWG.
Maximum cable length: 100 m.
- Voltage signal
0-10 VDC, $R_i > 50$ kΩ.
Tolerance: + 0 %/- 3 % at maximum voltage signal.
Screened cable: 0.5 - 1.5 mm² / 28-16 AWG.
Maximum cable length: 500 m.
- Current signal
DC 0-20 mA/4-20 mA, $R_i = 250$ Ω.
Tolerance: + 0 %/- 3 % at maximum current signal.
Screened cable: 0.5 - 1.5 mm² / 28-16 AWG.
Maximum cable length: 500 m.

Signal relay output

Potential-free changeover contact.

Maximum contact load: 250 VAC, 2 A, $\cos \varphi$ 0.3 - 1.

Minimum contact load: 5 VDC, 10 mA.

Screened cable: 0.5 - 2.5 mm² / 28-12 AWG.

Maximum cable length: 500 m.

Bus input

Grundfos bus protocol, GENIbus protocol, RS-485.

Screened 3-core cable: 0.2 - 1.5 mm² / 28-16 AWG.

Maximum cable length: 500 m.

23. Other technical data

EMC (electromagnetic compatibility to EN 61800-3)

Motor [kW]		Emission/immunity
2-pole	4-pole	
-	0.12	
0.18	0.18	
0.25	0.25	
0.37	0.37	Emission
0.55	0.55	Motors may be installed in residential areas (first environment), unrestricted distribution, corresponding to CISPR11, group 1, class B.
0.75	0.75	
1.1	1.1	
1.5	1.5	Immunity
2.2	2.2	Motors fulfil the requirements for both the first and second environment.
3.0	3.0	
4.0	4.0	
5.5	-	
7.5	-	
-	5.5	Emission
-	7.5	The motors are category C3, corresponding to CISPR11, group 2, class A, and may be installed in industrial areas (second environment).
11	11	If equipped with an external Grundfos EMC filter, the motors are category C2, corresponding to CISPR11, group 1, class A, and may be installed in residential areas (first environment).
15	15	
18.5	18.5	
22	-	



Warning

When the motors are installed in residential areas, supplementary measures may be required as the motors may cause radio interference.

Motor sizes 11, 18.5 and 22 kW comply with EN 61000-3-12 provided that the short-circuit power at the interface point between the user's electrical installation and the public power supply network is greater than or equal to the values stated below. It is the responsibility of the installer or user to ensure, by consultation with the power supply network operator, if necessary, that the motor is connected to a power supply with a short-circuit power greater than or equal to these values:

Motor size [kW]	Short-circuit power [kVA]
11	1500
15	-
18.5	2700
22	3000

Note

15 kW motors do not comply with EN 61000-3-12.

By installing an appropriate harmonic filter between the motor and the power supply, the harmonic current content will be reduced. In this way the 15 kW motor will comply with EN 61000-3-12.

Immunity

The motors fulfil the requirements for both the first and second environment.

Contact Grundfos for further information.

Enclosure class

- Single-phase pumps: IP55 (IEC 34-5).
- Three-phase pumps, 0.55 - 7.5 kW: IP55 (IEC 34-5).
- Three-phase pumps, 11-22 kW: IP55 (IEC 34-5).

Insulation class

F (IEC 85).

Ambient temperature

During operation:

- Min. -10 °C
- Max. +40 °C, without derating

During storage/transport:

- -30 - +60 °C (up to 7.5 kW)
- -25 - +70 °C (11-22 kW).

Relative air humidity

Maximum 95 %.

Sound pressure level**Single-phase pumps**

Less than 70 dB(A).

Three-phase pumps

Motor [kW]	Speed stated on nameplate [min ⁻¹]		Sound pressure level [dB(A)]
	2-pole	4-pole	
0.55		1400-1500	47
		1700-1800	52
0.75		1400-1500	47
		1700-1800	52
	2800-3000		60
	3400-3600		65
1.1		1400-1500	49
		1700-1800	53
	2800-3000		60
	3400-3600		65
1.5		1400-1500	53
		1700-1800	57
	2800-3000		65
	3400-3600		70
2.2		1400-1500	50
		1700-1800	52
	2800-3000		65
	3400-3600		70
3.0		1400-1500	55
		1700-1800	60
	2800-3000		65
	3400-3600		70
4.0		1400-1500	58
		1700-1800	63
	2800-3000		70
	3400-3600		75
5.5		1400-1500	57
		1700-1800	59
	2800-3000		75
	3400-3600		80
7.5		1400-1500	59
		1700-1800	61
	2800-3000		67
	3400-3600		72
11		1400-1500	63
		1700-1800	64
	2800-3000		64
	3400-3600		68
15		1400-1500	65
		1700-1800	66
	2800-3000		65
	3400-3600		68
18.5		1400-1500	69
		1700-1800	72
	2800-3000		69
	3400-3600		70
22		1400-1500	-
		1700-1800	-
	2800-3000		67
	3400-3600		70

24. Disposal

This product or parts of it must be disposed of in an environmentally sound way:

1. Use the public or private waste collection service.
2. If this is not possible, contact the nearest Grundfos company or service workshop.

Subject to alterations.

Appendix

1. Installation in the USA and Canada

Note In order to maintain the UL/cURus approval, follow these additional installation instructions. The UL approval is according to UL508C.

1.1 Electrical connection

1.1.1 Conductors

Use 140/167 °F (60/75 °C) copper conductors only.

1.1.2 Torques

Power terminals

Motor size [kW]	Thread size	Torque [Nm]
Up to 7.5 kW	M4	2.35
11-22 kW	M4	Min. 2.2 Max. 2.8

Relay, M2.5: 0.5 Nm.

Input control, M2: 0.2 Nm.

1.1.3 Line reactors

Max line reactor size must not exceed 2 mH.

1.1.4 Fuse size/circuit breaker

If a short circuit happens the pump can be used on a mains supply delivering not more than 5000 RMS symmetrical amperes, 600 V maximum.

Fuses

When the pump is protected by fuses they must be rated for 480 V. Maximum sizes are stated in table below.

Motors up to and including 7.5 kW require class K5 UL-listed fuses. Any UL-listed fuse can be used for motors from 11 to 22 kW.

Circuit breaker

When the pump is protected by a circuit breaker this must be rated for a maximum voltage of 480 V. The circuit breaker must be of the "Inverse time" type.

The interrupting rating (RMS symmetrical amperes) must not be less than the values stated in table below.

USA - hp

2-pole	4-pole	Fuse size	Circuit breaker type/model
1	1	25 A	25 A / Inverse time
1.5	1.5	25 A	25 A / Inverse time
2	2	25 A	25 A / Inverse time
3	3	25 A	25 A / Inverse time
5	5	40 A	40 A / Inverse time
7.5	-	40 A	40 A / Inverse time
10	7.5	50 A	50 A / Inverse time
15	15	80 A	80 A / Inverse time
20	20	110 A	110 A / Inverse time
25	25	125 A	125 A / Inverse time
30	-	150 A	150 A / Inverse time

Europe - kW

2-pole	4-pole	Fuse size	Circuit breaker type/model
-	0.55	25 A	25 A / Inverse time
0.75	0.75	25 A	25 A / Inverse time
1.1	1.1	25 A	25 A / Inverse time
1.5	1.5	25 A	25 A / Inverse time
2.2	2.2	25 A	25 A / Inverse time
3	3	25 A	25 A / Inverse time
4	4	40 A	40 A / Inverse time
5.5	-	40 A	40 A / Inverse time
7.5	5.5	50 A	50 A / Inverse time
11	11	80 A	80 A / Inverse time
15	15	110 A	110 A / Inverse time
18.5	18.5	125 A	125 A / Inverse time
22	-	150 A	150 A / Inverse time

1.1.5 Overload protection

Degree of overload protection provided internally by the drive, in percent of full-load current: 102 %.

1.2 General considerations

For installation in humid environment and fluctuating temperatures, it is recommended to keep the pump connected to the power supply continuously. This will prevent moisture and condensation build-up in the terminal box.

Start and stop must be done via the start/stop digital input (terminal 2-3).

Subject to alterations.

Argentina

Bombas GRUNDFOS de Argentina S.A.
Ruta Panamericana km. 37.500 Centro
Industrial Garin
1619 Garin Pcia. de B.A.
Phone: +54-3327 414 444
Telefax: +54-3327 45 3190

Australia

GRUNDFOS Pumps Pty. Ltd.
P.O. Box 2040
Regency Park
South Australia 5942
Phone: +61-8-8461-4611
Telefax: +61-8-8340 0155

Austria

GRUNDFOS Pumpen Vertrieb Ges.m.b.H.
Grundfosstraße 2
A-5082 Grödig/Salzburg
Tel.: +43-6246-883-0
Telefax: +43-6246-883-30

Belgium

N.V. GRUNDFOS Bellux S.A.
Boomssesteenweg 81-83
B-2630 Aartselaar
Tél.: +32-3-870 7300
Télécopie: +32-3-870 7301

Belarus

Представительство ГРУНДФОС в
Минске
220125, Минск
ул. Шафарнянская, 11, оф. 56, БЦ
«Порт»
Тел.: +7 (375 17) 286 39 72/73
Факс: +7 (375 17) 286 39 71
E-mail: minsk@grundfos.com

Bosna and Herzegovina

GRUNDFOS Sarajevo
Zmaja od Bosne 7-7A,
BH-71000 Sarajevo
Phone: +387 33 592 480
Telefax: +387 33 590 465
www.ba.grundfos.com
e-mail: grundfos@bih.net.ba

Brazil

BOMBAS GRUNDFOS DO BRASIL
Av. Humberto de Alencar Castelo Branco,
630
CEP 09850 - 300
São Bernardo do Campo - SP
Phone: +55-11 4393 5533
Telefax: +55-11 4343 5015

Bulgaria

Grundfos Bulgaria EOOD
Slatina District
Iztochna Tangenta street no. 100
BG - 1592 Sofia
Tel. +359 2 49 22 200
Fax. +359 2 49 22 201
email: bulgaria@grundfos.bg

Canada

GRUNDFOS Canada Inc.
2941 Brighton Road
Oakville, Ontario
L6H 6C9
Phone: +1-905 829 9533
Telefax: +1-905 829 9512

China

GRUNDFOS Pumps (Shanghai) Co. Ltd.
10F The Hub, No. 33 Suhong Road
Minhang District
Shanghai 201106
PRC
Phone: +86 21 612 252 22
Telefax: +86 21 612 253 33

Croatia

GRUNDFOS CROATIA d.o.o.
Buzinski prilaz 38, Buzin
HR-10010 Zagreb
Phone: +385 1 6595 400
Telefax: +385 1 6595 499
www.hr.grundfos.com

Czech Republic

GRUNDFOS s.r.o.
Čajkovského 21
779 00 Olomouc
Phone: +420-585-716 111
Telefax: +420-585-716 299

Denmark

GRUNDFOS DK A/S
Martin Bachs Vej 3
DK-8850 Bjerringbro
Tlf.: +45-87 50 50 50
Telefax: +45-87 50 51 51
E-mail: info_GDK@grundfos.com
www.grundfos.com/DK

Estonia

GRUNDFOS Pumps Eesti OÜ
Peterburi tee 92G
11415 Tallinn
Tel: + 372 606 1690
Fax: + 372 606 1691

Finland

OY GRUNDFOS Pumput AB
Trukkikuja 1
FI-01360 Vantaa
Phone: +358-(0) 207 889 500
Telefax: +358-(0) 207 889 550

France

Pompes GRUNDFOS Distribution S.A.
Parc d'Activités de Chesnes
57, rue de Malacombe
F-38290 St. Quentin Fallavier (Lyon)
Tél.: +33-4 74 82 15 15
Télécopie: +33-4 74 94 10 51

Germany

GRUNDFOS GMBH
Schlüterstr. 33
40699 Erkrath
Tel.: +49-(0) 211 929 69-0
Telefax: +49-(0) 211 929 69-3799
e-mail: infoservice@grundfos.de
Service in Deutschland:
e-mail: kundendienst@grundfos.de

Greece

GRUNDFOS Hellas A.E.B.E.
20th km. Athinon-Markopoulou Av.
P.O. Box 71
GR-19002 Peania
Phone: +0030-210-66 83 400
Telefax: +0030-210-66 46 273

Hong Kong

GRUNDFOS Pumps (Hong Kong) Ltd.
Unit 1, Ground floor
Siu Wai Industrial Centre
29-33 Wing Hong Street &
68 King Lam Street, Cheung Sha Wan
Kowloon
Phone: +852-27861706 / 27861741
Telefax: +852-27858664

Hungary

GRUNDFOS Hungária Kft.
Park u. 8
H-2045 Törökbálint,
Phone: +36-23 511 110
Telefax: +36-23 511 111

India

GRUNDFOS Pumps India Private Limited
118 Old Mahabalipuram Road
Thoraiakkam
Chennai 600 096
Phone: +91-44 2496 6800

Indonesia

PT. GRUNDFOS POMPA
Graha Intirub Lt. 2 & 3
Jin. Cililitan Besar No.454. Makasar,
Jakarta Timur
ID-Jakarta 13650
Phone: +62 21-469-51900
Telefax: +62 21-460 6910 / 460 6901

Ireland

GRUNDFOS (Ireland) Ltd.
Unit A, Merrywell Business Park
Ballymount Road Lower
Dublin 12
Phone: +353-1-4089 800
Telefax: +353-1-4089 830

Italy

GRUNDFOS Pompe Italia S.r.l.
Via Gran Sasso 4
I-20060 Truccazzano (Milano)
Tel.: +39-02-95838112
Telefax: +39-02-95309290 / 95838461

Japan

GRUNDFOS Pumps K.K.
Gotanda Metalion Bldg., 5F,
5-21-15, Higashi-gotanda
Shiagawa-ku, Tokyo
141-0022 Japan
Phone: +81 35 448 1391
Telefax: +81 35 448 9619

Korea

GRUNDFOS Pumps Korea Ltd.
6th Floor, Aju Building 679-5
Yeoksam-dong, Kangnam-ku, 135-916
Seoul, Korea
Phone: +82-2-5317 600
Telefax: +82-2-5633 725

Latvia

SIA GRUNDFOS Pumps Latvia
Deglava biznesa centrs
Augusta Deglava ielā 60, LV-1035, Rīga,
Tālr.: + 371 714 9640, 7 149 641
Fakss: + 371 914 9646

Lithuania

GRUNDFOS Pumps UAB
Smolensko g. 6
LT-03201 Vilnius
Tel: + 370 52 395 430
Fax: + 370 52 395 431

Malaysia

GRUNDFOS Pumps Sdn. Bhd.
7 Jalan Peguam U1/25
Glenmarie Industrial Park
40150 Shah Alam
Selangor
Phone: +60-3-5569 2922
Telefax: +60-3-5569 2866

Mexico

Bombas GRUNDFOS de México S.A. de
C.V.
Boulevard TLC No. 15
Parque Industrial Stiva Aeropuerto
Apodaca, N.L. 66600
Phone: +52-81-8144 4000
Telefax: +52-81-8144 4010

Netherlands

GRUNDFOS Netherlands
Veluwezoom 35
1326 AE Almere
Postbus 22015
1302 CA ALMERE
Tel.: +31-88-478 6336
Telefax: +31-88-478 6332
E-mail: info_gnl@grundfos.com

New Zealand

GRUNDFOS Pumps NZ Ltd.
17 Beatrice Tinsley Crescent
North Harbour Industrial Estate
Albany, Auckland
Phone: +64-9-415 3240
Telefax: +64-9-415 3250

Norway

GRUNDFOS Pumper A/S
Strømsveien 344
Postboks 235, Leirdal
N-1011 Oslo
Tlf.: +47-22 90 47 00
Telefax: +47-22 32 21 50

Poland

GRUNDFOS Pompy Sp. z o.o.
ul. Klonowa 23
Baranowo k. Poznania
PL-62-081 Przeźmierowo
Tel: (+48-61) 650 13 00
Fax: (+48-61) 650 13 50

Portugal

Bombas GRUNDFOS Portugal, S.A.
Rua Calvet de Magalhães, 241
Apartado 1079
P-2770-153 Paço de Arcos
Tel.: +351-21-440 76 00
Telefax: +351-21-440 76 90

Romania

GRUNDFOS Pompe România SRL
Bd. Biruintei, nr 103
Pantelimon county Ilfov
Phone: +40 21 200 4100
Telefax: +40 21 200 4101
E-mail: romania@grundfos.ro

Russia

ООО Грундфос Россия
109544, г. Москва, ул. Школьная, 39-41,
стр. 1
Тел. (+7) 495 564-88-00 (495) 737-30-00
Факс (+7) 495 564 88 11
E-mail grundfos.moscow@grundfos.com

Serbia

Grundfos Srbija d.o.o.
Omladinskih brigada 90b
11070 Novi Beograd
Phone: +381 11 2258 740
Telefax: +381 11 2281 769
www.rs.grundfos.com

Singapore

GRUNDFOS (Singapore) Pte. Ltd.
25 Jalan Tukang
Singapore 619264
Phone: +65-6681 9688
Telefax: +65-6681 9689

Slovakia

GRUNDFOS s.r.o.
Prievozská 4D
821 09 BRATISLAVA
Phona: +421 2 5020 1426
sk.grundfos.com

Slovenia

GRUNDFOS d.o.o.
Šlandrova 8b, SI-1231 Ljubljana-Črnuče
Phone: +386 31 718 808
Telefax: +386 (0)1 5680 619
E-mail: slovenia@grundfos.si

South Africa

GRUNDFOS (PTY) LTD
Corner Mountjoy and George Allen Roads
Wilbart Ext. 2
Bedfordview 2008
Phone: (+27) 11 579 4800
Fax: (+27) 11 455 6066
E-mail: lsmart@grundfos.com

Spain

Bombas GRUNDFOS España S.A.
Camino de la Fuentesilla, s/n
E-28110 Algete (Madrid)
Tel.: +34-91-848 8800
Telefax: +34-91-628 0465

Sweden

GRUNDFOS AB
Box 333 (Lunnagårdsgatan 6)
431 24 Mölndal
Tel.: +46 31 332 23 000
Telefax: +46 31 331 94 60

Switzerland

GRUNDFOS Pumpen AG
Bruggacherstrasse 10
CH-8117 Fällanden/ZH
Tel.: +41-44-806 8111
Telefax: +41-44-806 8115

Taiwan

GRUNDFOS Pumps (Taiwan) Ltd.
7 Floor, 219 Min-Chuan Road
Taichung, Taiwan, R.O.C.
Phone: +886-4-2305 0868
Telefax: +886-4-2305 0878

Thailand

GRUNDFOS (Thailand) Ltd.
92 Chaloen Phrakiat Rama 9 Road,
Dokmai, Pravej, Bangkok 10250
Phone: +66-2-725 8999
Telefax: +66-2-725 8998

Turkey

GRUNDFOS POMPA San. ve Tic. Ltd. Sti.
Gebze Organize Sanayi Bölgesi
Ihsan dede Caddesi,
2. yol 200. Sokak No. 204
41490 Gebze/ Kocaeli
Phone: +90 - 262-679 7979
Telefax: +90 - 262-679 7905
E-mail: satis@grundfos.com

Ukraine

Бізнес Центр Європа
Столичне шосе, 103
м. Київ, 03131, Україна
Телефон: (+38 044) 237 04 00
Факс: (+38 044) 237 04 01
E-mail: ukraine@grundfos.com

United Arab Emirates

GRUNDFOS Gulf Distribution
P.O. Box 16768
Jebel Ali Free Zone
Dubai
Phone: +971 4 8815 166
Telefax: +971 4 8815 136

United Kingdom

GRUNDFOS Pumps Ltd.
Grovebury Road
Leighton Buzzard/Beds. LU7 4TL
Phone: +44-1525-850000
Telefax: +44-1525-850011

U.S.A.

GRUNDFOS Pumps Corporation
17100 West 118th Terrace
Olathe, Kansas 66061
Phone: +1-913-227-3400
Telefax: +1-913-227-3500

Uzbekistan

Grundfos Tashkent, Uzbekistan The
Representative Office of Grundfos
Kazakhstan in Uzbekistan
38a, Oybek street, Tashkent
Телефон: (+998) 71 150 3290 / 71 150
3291
Факс: (+998) 71 150 3292

Addresses Revised 29.09.2015

96782378 1215

ECM: 1171867
