

APG

50 Hz

Installation and operating instructions

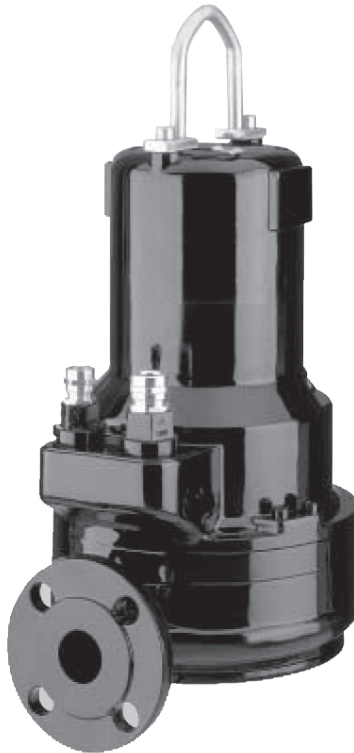

APG

English (GB)

Installation and operating instructions 5

Български (BG)

Упътване за монтаж и експлоатация 21

Deutsch (DE)

Montage- und Betriebsanleitung 38

Dansk (DK)

Monterings- og driftsinstruktion 55

Español (ES)

Instrucciones de instalación y funcionamiento 71

Suomi (FI)

Asennus- ja käyttöohjeet 88

Français (FR)

Notice d'installation et de fonctionnement 104

Ελληνικά (GR)

Οδηγίες εγκατάστασης και λειτουργίας 121

Hrvatski (HR)

Montažne i pogonske upute 138

Magyar (HU)

Telepítési és üzemeltetési utasítás 154

Italiano (IT)

Istruzioni di installazione e funzionamento 171

Nederlands (NL)

Installatie- en bedieningsinstructies 188

Norsk (NO)

Installasjons- og driftsinstruksjoner 205

Polski (PL)

Instrukcja montażu i eksploatacji 221

Português (PT)

Instruções de instalação e funcionamento 238

Română (RO)

Instrucțiuni de instalare și utilizare 255

Srpski (RS)

Uputstvo za instalaciju i rad 271

| | |
|--|-----|
| Русский (RU) | |
| Паспорт, Руководство по монтажу и эксплуатации | 287 |
| Svenska (SE) | |
| Monterings- och driftsinstruktion | 304 |
| Türkçe (TR) | |
| Montaj ve kullanım kılavuzu | 320 |
| 中文 (CN) | |
| 安装和使用说明书 | 336 |
| (AR) العربية | |
| تعليمات التركيب و التشغيل | 352 |

English (GB) Installation and operating instructions

Original installation and operating instructions

Table of contents

| | |
|---|-----------|
| 1. General information | 5 |
| 1.1 Hazard statements | 5 |
| 1.2 Notes | 5 |
| 2. Product introduction | 6 |
| 2.1 Pumped liquids | 6 |
| 2.2 Identification. | 6 |
| 3. Receiving the product. | 7 |
| 3.1 Transporting the product | 7 |
| 3.2 Handling and lifting the product | 7 |
| 4. Mechanical installation | 7 |
| 4.1 Installation requirements | 7 |
| 4.2 Installation on auto coupling | 7 |
| 4.3 Free-standing installation | 9 |
| 5. Electrical connection | 10 |
| 5.1 Level controllers. | 10 |
| 5.2 Motor protection. | 11 |
| 6. Startup | 14 |
| 6.1 Direction of rotation | 15 |
| 7. Storing the product | 16 |
| 8. Servicing the product | 16 |
| 8.1 Maintenance schedule | 17 |
| 8.2 Cutter head replacement | 17 |
| 8.3 Contaminated pumps | 18 |
| 9. Fault finding | 19 |
| 9.1 Motor does not start. Fuses blow, or motor starter trips immediately. | 19 |
| 9.2 Pump operates, but motor starter trips after a short while. | 19 |
| 9.3 Pump operates at below-standard performance and power consumption. | 19 |
| 9.4 Pump operates, but supplies no liquid. | 19 |
| 10. Technical data | 20 |
| 10.1 Operating conditions | 20 |
| 11. Disposing of the product | 20 |

1. General information



Read this document before you install the product. Installation and operation must comply with local regulations and accepted codes of good practice.

1.1 Hazard statements

The symbols and hazard statements below may appear in Grundfos installation and operating instructions, safety instructions and service instructions.



DANGER

Indicates a hazardous situation which, if not avoided, will result in death or serious personal injury.



WARNING

Indicates a hazardous situation which, if not avoided, could result in death or serious personal injury.



CAUTION

Indicates a hazardous situation which, if not avoided, could result in minor or moderate personal injury.

The hazard statements are structured in the following way:



SIGNAL WORD

Description of the hazard

Consequence of ignoring the warning

- Action to avoid the hazard.

1.2 Notes

The symbols and notes below may appear in Grundfos installation and operating instructions, safety instructions and service instructions.



Observe these instructions for explosion-proof products.



A blue or grey circle with a white graphical symbol indicates that an action must be taken.



A red or grey circle with a diagonal bar, possibly with a black graphical symbol, indicates that an action must not be taken or must be stopped.



If these instructions are not observed, it may result in malfunction or damage to the equipment.



Tips and advice that make the work easier.

2. Product introduction

2.1 Pumped liquids

Grundfos APG pumps are designed for pumping:

- wastewater
- sludge-containing water
- groundwater
- sewage from restaurants, hotels, campsites and other facilities.

The compact design makes the pumps suitable for both temporary and permanent installation. They are also suitable for free-standing installation as well as installation on an auto-coupling system.

APG pumps are equipped with a cutter system which cuts all destructible solids into small pieces so that they can flow through relatively small diameter pipes.



The pumps must not be used for pumping combustible, flammable or corrosive liquids.

2.2 Identification

2.2.1 Nameplate

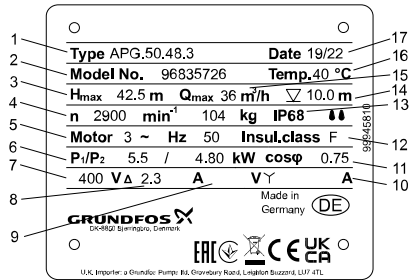

| Pos. | Description |
|------|--------------------------------------|
| 1 | Type designation |
| 2 | Model number |
| 3 | Maximum head |
| 4 | Rated speed |
| 5 | Number of phases |
| 6 | Rated input power/rated output power |
| 7 | Rated voltage, D |
| 8 | Rated current, D |
| 9 | Rated voltage, Y |
| 10 | Rated current, Y |
| 11 | Cos φ, 1/1-load |
| 12 | Insulation class |
| 13 | Enclosure class to IEC |
| 14 | Maximum installation depth |
| 15 | Maximum flow rate |
| 16 | Maximum liquid temperature |
| 17 | Production code (year/week) |

3. Receiving the product

3.1 Transporting the product

The pump can be transported and stored in vertical or horizontal position. Make sure that it cannot roll or fall over. Make sure that the received product corresponds to the order. In case of damage or missing parts, inform the transport company or the manufacturer immediately.

3.2 Handling and lifting the product

All lifting equipment must be rated for the purpose and checked for damage before lifting the pump. The lifting equipment rating must not be exceeded. The pump weight is stated on the nameplate.

WARNING

Crushing hazard

Death or serious personal injury



- Do not stack pump packages or pallets on top of each other when lifting or moving them.
- Always lift the pump by its lifting bracket or by a forklift truck, if the pump is fixed on a pallet. Never lift the pump by the power cable, hose or pipe.

CAUTION

Sharp element

Minor or moderate personal injury



- Wear protective gloves when opening the pump package.



Keep the cable end protectors in storage for later use.

WARNING

Crushing hazard

Death or serious personal injury



- Make sure that your hand cannot get caught between the lifting bracket and the hook.

WARNING

Crushing hazard

Death or serious personal injury



- Make sure that the hook is fixed to the lifting bracket properly.
- Always lift the pump by its lifting bracket or by a forklift truck, if the pump is fixed on a pallet.
- Make sure that the lifting bracket is tightened before lifting the pump.

4. Mechanical installation

The extra nameplate supplied with the pump should be fixed at the installation site.

Prior to installation, check the oil level in the oil chamber.

Related information

8. Servicing the product

4.1 Installation requirements



Pump installation in pits must be carried out by specially trained persons.

DANGER

Electric shock

Death or serious personal injury



- It must be possible to lock the main switch in position 0. Type and requirements are specified in EN 60204-1.

DANGER

Electric shock

Death or serious personal injury



- Make sure that there is at least 3 m free cable above the maximum liquid level.



Maintenance and service work must be carried out when the pump is outside the pit. For safety reasons, all work inside pits must be supervised by a person outside the pit.

WARNING

Crushing hazard

Death or serious personal injury



- Make sure that the lifting bracket is tightened before lifting the pump.

4.2 Installation on auto coupling

Pumps for permanent installation can be installed on a stationary auto-coupling base and operated completely or partially submerged in the pumped liquid.

Make sure that the pipes are installed without the use of undue force. No loads from the weight of the pipes must be carried by the pump. Use loose flanges to ease the installation and to avoid pipe tension at the flanges.





Do not use elastic elements or bellows to connect the pipes.



In some installations, a plinth is required beneath the auto coupling to ensure the correct installation of the pump.



The free end of the cable must not be submerged as water may penetrate into the motor.

1. Drill mounting holes for the guide-rail bracket on the inside of the pit, and fasten it provisionally with two screws.
2. Place the auto-coupling base unit on the bottom of the pit. Use a plumb line to establish the correct position. Fasten the auto-coupling base unit with heavy-duty expansion bolts. If the bottom of the pit is uneven, the auto-coupling base unit must be supported so that it is level when fastened.
3. Assemble the discharge line according to the procedures and without exposing it to distortion or tension.
4. Insert the guide-rails in the rings of the auto-coupling base unit, and adjust their length to the guide rail bracket accurately.
5. Unscrew the provisionally fastened guide rail bracket, fit it on top of the guide-rails, and fasten it to the pit wall firmly.
6. Clean any debris from the pit before lowering the pump into it.
7. Fit the auto coupling to the discharge port of the pump. Slide the guide bar of the auto coupling between the guide rails, and lower the pump into the pit by using a chain. When the pump reaches the auto-coupling base unit, it automatically connects tightly.
8. Hang the end of the chain on a suitable hook at the top of the pit.
9. Adjust the length of the motor cable by coiling it up on a relief fitting so the cable is not damaged during operation. Fasten the relief fitting to a suitable bracket at the top of the pit. Make sure that the cables are not sharply bent or pinched.

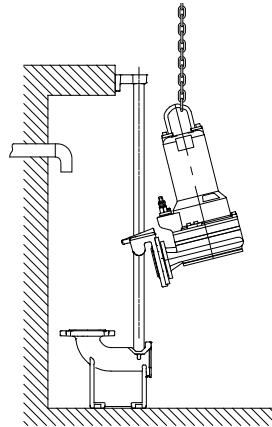

Lowering the pump to the auto-coupling base

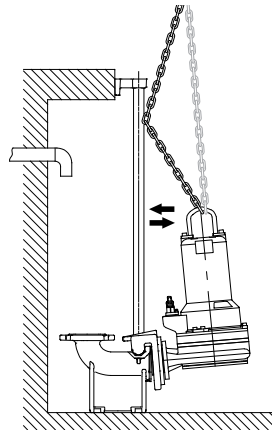

Connecting the pump to the auto-coupling base

TM082430

TM082431

4.3 Free-standing installation

! The free end of the cable must not be submerged as water may penetrate into the motor.

! If several pumps are installed in the same pit, the pumps must be installed at the same level to allow optimal pump alternation.

APG pumps are provided with a separate base stand.

For free-standing installation of the pumps, fit a 90° elbow on the discharge port. The pumps can be installed either with a hose or a rigid pipe and valves.

Pumps for submerged ring-stand installation can stand freely at the bottom of the pit or at any similar location.

If a hose is used, make sure that it does not buckle and that its inside diameter matches the outlet.

If a rigid pipe is used, fit the parts in the following order:

1. union or coupling
2. non-return valve
3. isolating valve.

If it is installed in muddy conditions or on uneven ground, place the pump on bricks.

1. Fit a 90° elbow to the pump outlet and connect the outlet pipe or hose.
2. Lower the pump into the liquid using a chain secured to the lifting bracket. Place the pump on a plain, solid foundation.
3. Hang the end of the chain on a suitable hook at the top of the pit. Make sure that the chain cannot come into contact with the pump housing.
4. Adjust the length of the power cable by coiling it up on a relief fitting to ensure that the cable is not damaged during operation. Fasten the relief fitting to a suitable hook at the top of the pit. Make sure that the cables are not sharply bent or pinched.
5. Connect the power cable and the control cable, if any.

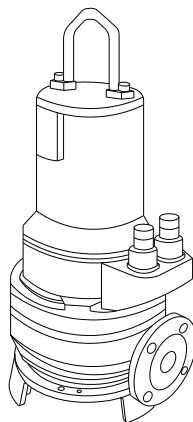

Installation on ring stand

TM082432

5. Electrical connection

The electrical connection of the pump must be carried out according to local regulations.

The operating voltage and frequency are stated on the nameplate. Voltage tolerance: $\pm 10\%$ of the voltage stated on the nameplate. Make sure that the motor is suitable for the power supply available at the installation site.

DANGER

Electric shock

Death or serious personal injury



- Connect the pump to an external main switch, which ensures all-pole disconnection with a contact separation according to EN 60204-1.
- It must be possible to lock the main switch in position 0. Type and requirements as specified in EN 60204-1.



The permanent installation must be fitted with an earth-leakage circuit breaker.



Make sure that there are at least 3 metres of free cable above the maximum liquid level.

DANGER

Electric shock

Death or serious personal injury



- If the power cable is damaged, it must be replaced by the manufacturer, a service agent or a similarly qualified person.



Set the motor-protective circuit breaker to the rated current of the pump. The rated current is stated on the nameplate.

The supply voltage and frequency are marked on the nameplate. Make sure that the power supply at the installation site is suitable for the pump motor.

All pumps are supplied with a 10-metre cable and a free cable end.

DANGER

Electric shock

Death or serious personal injury



- Before the first startup, check the cable for visible defects to avoid short circuits.

The pumps must be connected to one of the following:

- a control unit with motor-protective circuit breaker, such as Grundfos CU 100

- Grundfos LC 231 or 241 pump controller.



Pumps cannot be operated with frequency converter.

5.1 Level controllers

The liquid level can be controlled by the Grundfos LC level controllers.

Suitable level controllers:

- LC 231: compact solution with certified motor protection for single- and dual-pump versions.
- LC 241: cabinet solution offering modularity and customisation for single- and dual-pump versions.

In the following description, "level switches" can be air bells, float switches or electrodes depending on the selected pump controller.

Depending on the security levels and the number of pumps, level switches can be used in the following setups:

- Dry run (optional)
- Stop
- Start pump 1 (single-pump version)
- Start pump 2 (dual-pump version)
- High level (optional)

Analogue level transmitters can be used, and all levels can be customised. Level switches can be used with level transmitters, for dry-run protection and high level alarm.



The pump must not run dry. Install an additional level switch to ensure that the pump is stopped in case the stop level switch is not operating.

5.1.1 Installing level switches

When installing the level switches, observe the following points:

- To prevent air intake and vibrations, install the stop level switch, so the pump is stopped before the liquid level is lowered to the middle of the motor housing.
- Install the start level switch, so the pump is started at the required level. The pump must always start before the liquid level reaches the bottom inlet pipe.
- Always install the high-level alarm switch about 10 cm above the start level switch. However, the alarm must always be given before the liquid level reaches the inlet pipe.

For further settings and information, see the installation and operating instructions for the selected level controllers.

5.2 Motor protection

All pumps are supplied with 10 metres of cable and a free cable end.

APG pumps of 4.8 kW and above are prepared for star-delta starting, such as both ends of the motor windings are accessible through the motor cable.

- T1 and T3 are connected to the standard set of bimetallic switches.
- T1 and T2 are connected to the extra set of temperature sensors in explosion-proof pumps. T2 is not used in standard execution, only for APG on special request.
- S1 and S2 are connected to a moisture sensor in the oil chamber.

5.2.1 Temperature sensors (in stator windings)

All pumps have integrated temperature sensors in the stator windings.

Non-explosion proof pumps only have one set of bimetallic switches.

Explosion proof pumps have two sets of temperature sensors. The extra set of sensors opens at a temperature that is about 10 °C higher than the opening temperature of standard sensors. The extra set of sensors provides additional protection against overtemperature in potentially explosive environments.

The temperature sensors must be connected to the safety circuit of the motor-protective circuit breaker through the temperature relay (No. 98123042).

The temperature sensors are connected to the monitoring cable and must be connected to the separate thermistor relay fitted in the safety circuit of the pump controller.

The temperature sensors of pumps above 1.6 kW and three-phase motors are connected to the power supply cable. To ensure automatic restart of the motor when cooled (to ambient temperature), the leads

marked T1 and T3 must be connected to the safety circuit. The same applies to the leads marked T1 and T2 in explosion proof versions.



Separate motor-protective circuit breakers/control boxes must not be installed in potentially explosive environments.

5.2.1.1 Wiring diagram

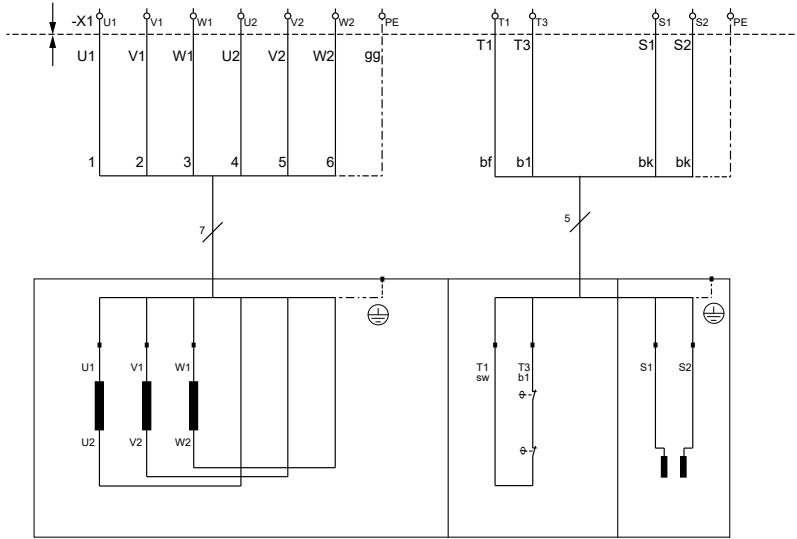

TM082770

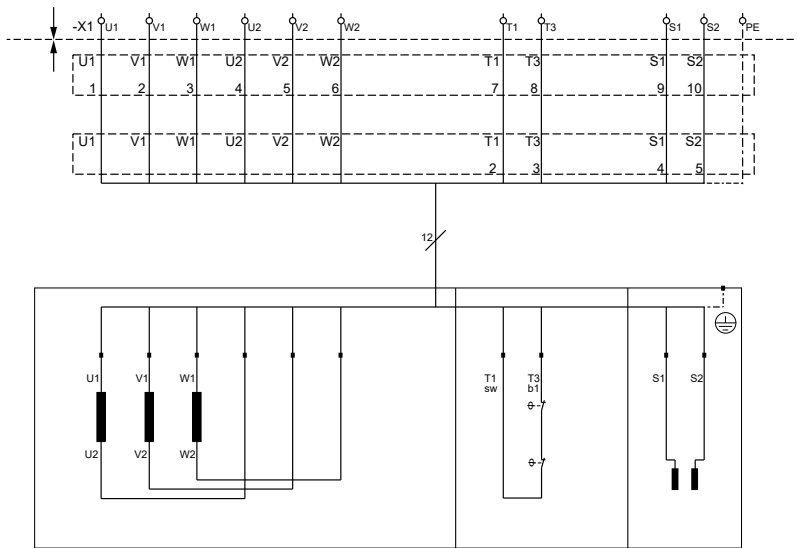

TM082771

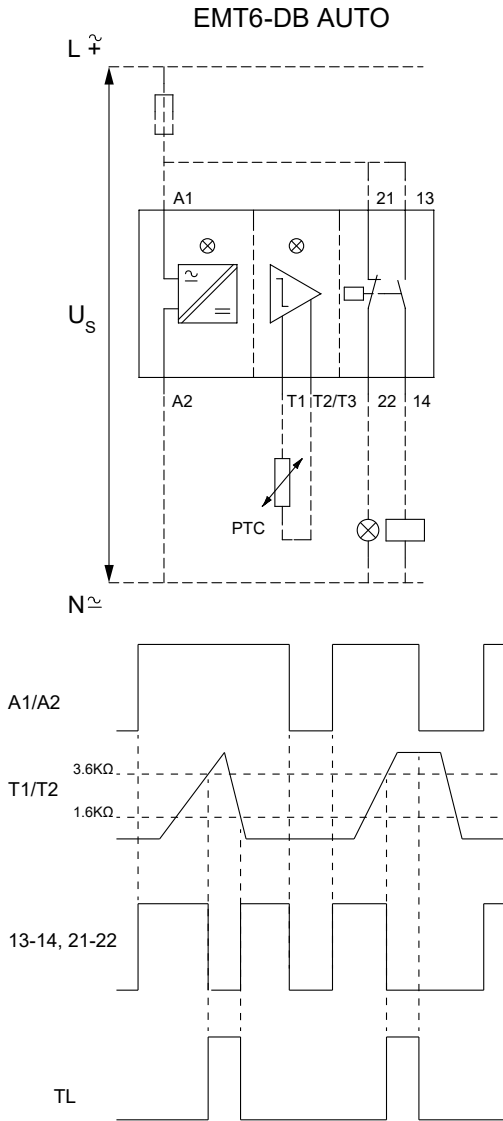

Wiring diagram, temperature relay

| Pos. | Description |
|------|-------------|
| TL | Tripped LED |

TM053448

5.2.2 Moisture sensor

This section applies only to APG.50.48, APG.50.65 and APG.50.92.

Pumps with moisture sensor have a sensor in the oil chamber between the motor and the pump housing. Through the separate level relay (No. 99010129), the moisture sensor transmits a signal to the safety circuit to trip the motor in case of ingress of moisture/water into the pump. See fig. below.

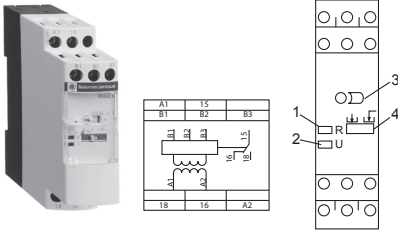

TM 052304

Moisture relay wiring

6. Startup

Before starting the product:

- Make sure that the fuses are removed.
- Make sure that all protective equipment is connected correctly.
- Check the oil level.
- Test the insulation resistance.



CAUTION Hot surface

Minor or moderate personal injury

- If the float switches do not work properly, dry running the pump may cause overheating. Make sure that the float switches can move freely.



CAUTION Crushing of hands

Minor or moderate personal injury

- Do not put your hands or any tool into the pump inlet or outlet after the pump is connected to the power supply, unless it is switched off by removing the fuses or switching off the main switch.
- Make sure that the power supply cannot be switched on unintentionally.



CAUTION

Biological hazard

Minor or moderate personal injury

- Make sure to seal the pump outlet properly when fitting the outlet pipe, otherwise water might spray out.



WARNING

Crushing of hands

Death or serious personal injury

- When lifting the pump, make sure that your hand cannot get caught between the lifting bracket and the hook.



DANGER

Crushing hazard

Death or serious personal injury

- Make sure that the hook is fixed properly to the lifting bracket.
- Always lift the pump by its lifting bracket or by a forklift truck, if the pump is fixed on a pallet.
- Never lift the pump by the power cable, hose or pipe.
- Make sure that the lifting bracket is tightened before lifting the pump.



DANGER

Electric shock

Death or serious personal injury

- Before the first start-up, check the power cable for visible defects to avoid short circuits.
- If the power cable is damaged, it must be replaced either by the manufacturer, a service agent or a similarly qualified person.
- Make sure that the product is earthed properly.
- Switch off the power supply and lock the main switch in position 0.
- Switch off any external voltage connected to the product before working on it.



CAUTION

Biological hazard

Minor or moderate personal injury

- Flush the pump thoroughly with clean water and rinse the pump parts after dismantling.
- Wear appropriate personal protective equipment and clothing.



**CAUTION****Hot surface**

Minor or moderate personal injury

- Do not touch the surface of the pump while it is running.

Proceed as follows:

1. Check the oil level in the oil chamber.
2. Remove the fuses, and check whether the impeller can rotate freely.
3. Check whether the monitoring units, if used, are operating satisfactorily.
4. Check whether the system is filled with liquid and vented.
5. Make sure that the pump is submerged in the liquid.
6. Open the isolating valves, if fitted.
7. Check the setting of the level switches.
8. Start the pump.



The pump can be started for a very short period of time without being submerged to check the direction of rotation.

6.1 Direction of rotation

Before starting up three-phase pumps, check the direction of rotation. The direction of rotation should be clockwise when viewed from above. When starting up, the pump jerks in the opposite direction of the direction of rotation. If the direction of rotation is wrong, interchange two of the three phases of the power supply.

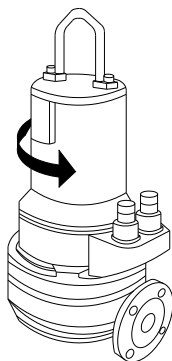

Jerk direction



The direction check must be performed outside of the hazardous area.

6.1.1 Direction of rotation check: Procedure 1

The direction of rotation must be checked every time the pump is connected to a new installation.

1. Start the pump, and check the quantity of water or the discharge pressure.
2. Stop the pump, and interchange two of the three phases to the motor.
3. Start the pump, and check the quantity of water or the discharge pressure.
4. Stop the pump.
5. Compare the results from points 1 and 3. The phase connection which gives the larger quantity of water or the higher pressure gives the correct direction of rotation.

6.1.2 Direction of rotation check: Procedure 2

The direction of rotation must be checked every time the pump is connected to a new installation.

1. Let the pump hang from a lifting device such as the chain used for lowering the pump into the pit.
2. Start and stop the pump while observing the movement (jerk) of the pump.
3. If connected correctly, the pump jerks counterclockwise.
4. If the direction of rotation is wrong, interchange two phases in the power cable.

TM082433

7. Storing the product

For periods of storage the pump must be protected against moisture and heat.

After a period of storage, inspect the pump before putting it into operation. Make sure that the impeller can rotate freely. Pay attention to the condition of the shaft seals, O-rings and the cable entries.



Leave the cable-end protectors on the power and control cables until starting the electrical connection. Whether insulated or not, the free cable end must never be exposed to moisture or water. Non-compliance with this may cause damage to the motor.



If the pump is being stored for more than one month, turn the impeller at least every month to prevent the seal faces of the lower mechanical shaft seal from seizing up.

If you do not do this, the shaft seal may be damaged when the pump is started.

If the impeller cannot be turned, contact Grundfos or an authorised service workshop.



WARNING Crushing hazard

- Death or serious personal injury
- Do not turn the impeller by hand. Always use an appropriate tool.

8. Servicing the product

WARNING

Electric shock

Death or serious personal injury

- Before working on the product, switch off the power supply. Make sure that the power supply cannot be switched on unintentionally.



CAUTION

Crushing of hands

Minor or moderate personal injury

- Make sure that all rotating parts stopped moving.



Before maintenance and service, make sure that the pump is thoroughly flushed with clean water. Rinse the pump parts in water after dismantling.

CAUTION

Pressurised system

Minor or moderate personal injury

- When unscrewing the inspection screw of the oil chamber, note that pressure may have built up in the chamber. Do not remove the screw until the pressure is fully relieved.



CAUTION

Crushing of feet

Minor or moderate personal injury

- Make sure the pump cannot roll or fall over.



CAUTION

Hot surface

Minor or moderate personal injury

- Make sure that the pump has cooled down before touching it.



Normally operating pumps should be inspected at least once a year. If the pumped liquid is very muddy or sandy, inspect the pump at shorter intervals.

When the pump is new or after replacement of the shaft seals, check the oil level after one week of operation.

For long and trouble-free operation of the pump, check the following points regularly:

- power consumption
- oil level and oil condition.

If the oil contains water, it becomes greyish white. Water in the oil may be due to a defective shaft seal. The oil should be replaced after 3000 hours of operation. Use Shell Ondina X420 oil or a similar type.



Used oil must be disposed of according to local regulations.

| Pump type | Quantity of oil in oil chamber [l] |
|-----------|------------------------------------|
| APG.50.48 | 1.90 |
| APG.50.65 | 1.90 |
| APG.50.92 | 1.90 |

- Cable entry
Make sure that the cable entry is watertight and that the cables are not bent sharply or pinched.
- Pump parts
Check the impeller, pump housing, neck ring and other parts for possible wear. Replace defective parts.
- Ball bearings
Check the shaft for noisy or heavy operation (turn the shaft by hand). Replace defective ball bearings. A general overhaul of the pump is required in case of defective ball bearings or poor motor function. This work must be carried out by the manufacturer or a competent workshop.

8.1 Maintenance schedule

Before initial startup or after a longer period of storage:

- Check the insulation resistance.
- Check the fill level in the sealing chamber.
- Check possible damage on the axial face seal.

Monthly:

- Monitor the power input and voltage.
- Check the used switchgears for resistance and sealed space control.

Every six months:

- Inspect the power supply cable.
- Inspect the cable holder and wiring.
- Inspect the accessories, such as the suspension device and hoisting gears.

After 1000 operating hours or after six months, whichever is earlier:

- Monitor current consumption and voltage
- Check the relays for resistors, sealing room, etc.
- Inspect power supply cable
- Inspect cable holder and cable bracing
- Inspect accessories, e.g. suspension device and hoisting gears

After 3000 operating hours:

- Perform visual check of the pump and inspect the wear ring.

- Check the oil level and condition. Change the oil. Change the shaft seal in case of water ingress or oil leakage.
- Check the hydraulic components and wear ring for wear. Replace if necessary.

After 8000 operating hours or two years:

- Check the insulation resistance
- Empty the leakage chamber. Not available for all models. For more information, contact Grundfos.
- Inspect all safety and control devices.
- Check the coating and touch-up as required.

After 15 000 operating hours or five years:

- General overhaul.



If the pump is used in highly abrasive or corrosive matter, the maintenance intervals should be reduced.

Tightening torques

| | A2/A4, Hardness class 70 | A2/A4, Hardness class 80 |
|-----|--------------------------|--------------------------|
| | DIN912 / DIN933 | |
| M6 | 7 Nm | 11.8 Nm |
| M8 | 17 Nm | 28.7 Nm |
| M10 | 33 Nm | 58 Nm |
| M12 | 57 Nm | 100 Nm |
| M16 | 140 Nm | 245 Nm |
| M20 | 273 Nm | 494 Nm |

8.2 Cutter head replacement

Remove the cutter head.

Fit the new cutter head as follows:

1. Knock guide pin (560) into cutter head (23).
2. Fit the cutter head with guide pin on impeller (230). Fit and tighten screw (900.01).
3. Fit threaded pins (904) in suction cover (162).
4. Fit O-ring (412.01) in the suction cover, and grease the cover.
5. Knock the suction cover into pump housing (101) until the suction cover bears against the impeller. Check through the inlet port.
6. Tighten all threaded pins (904) until they easily touch pump housing (101).
7. Give all threaded pins a quarter of a turn.
8. Fasten the suction cover with screws (914.01).
9. Fit cutting ring (50) to the suction cover. Fit and tighten screws (900.02).

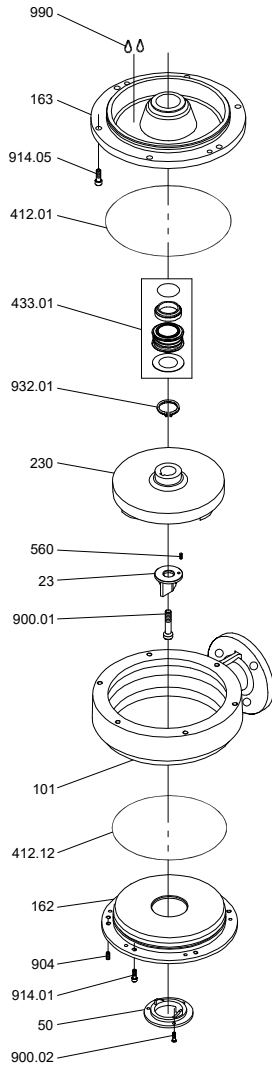

TM0017812

Exploded view

| Pos. | Component |
|------|----------------|
| 23 | Cutter head |
| 50 | Cutting ring |
| 101 | Pump housing |
| 162 | Suction cover |
| 163 | Pressure cover |

| Pos. | Component |
|--------|-----------------|
| 230 | Impeller |
| 412.01 | O-ring |
| 412.12 | O-ring |
| 433.01 | Mechanical seal |
| 560 | Dowel pin |
| 900.01 | Screw |
| 900.02 | Screw |
| 904 | Threaded pin |
| 914.01 | Screw |
| 914.05 | Screw |
| 932.01 | Circlip |
| 990 | Motor oil |

8.3 Contaminated pumps



If used for toxic or infectious liquid, the pump is classified as contaminated.

If Grundfos is requested to service the pump, Grundfos must be contacted with details about the pumped liquid before the pump is returned for service. Otherwise, Grundfos can refuse to accept the pump for service.

Possible costs of returning the pump to the customer are paid by the customer.

9. Fault finding

WARNING

Electric shock

Death or serious personal injury



- Before starting fault finding, switch off the power supply. Make sure that the power supply cannot be switched on unintentionally.

CAUTION

Crushing of hands

Minor or moderate personal injury



- Make sure that all rotating parts stopped moving.

9.1 Motor does not start. Fuses blow, or motor starter trips immediately.

Caution: Do not start again!

| Cause | Remedy |
|--|---|
| Supply failure; short-circuit; earth-leakage fault in cable or motor winding | <ul style="list-style-type: none"> • Have the cable and motor checked and repaired by a qualified electrician. |
| Fuses blow as they are not the right type | <ul style="list-style-type: none"> • Install fuses of the correct type. |
| Impeller is blocked by impurities | <ul style="list-style-type: none"> • Clean the impeller. |

9.2 Pump operates, but motor starter trips after a short while.

| Cause | Remedy |
|---|---|
| Low setting of thermal relay in motor starter | <ul style="list-style-type: none"> • Set the relay according to the specifications on the nameplate. |
| Increased current consumption due to large voltage drop | <ul style="list-style-type: none"> • Measure the voltage between motor phases. Tolerance: $\pm 10\%$. |
| Impeller is blocked by impurities. Increased current consumption in all three phases. | <ul style="list-style-type: none"> • Clean the impeller. |

9.3 Pump operates at below-standard performance and power consumption.

| Cause | Remedy |
|---------------------------------|---|
| Impeller blocked by impurities. | <ul style="list-style-type: none"> • Clean the impeller. |
| Wrong direction of rotation. | |

| Cause | Remedy |
|-------|---|
| | <ul style="list-style-type: none"> • Check the direction of rotation, and, if necessary, interchange two phases. |

9.4 Pump operates, but supplies no liquid.

| Cause | Remedy |
|--------------------------------------|--|
| Discharge valve is closed or blocked | <ul style="list-style-type: none"> • Check the discharge valve, and open and/or clean it, if necessary. |
| Non-return valve is blocked | <ul style="list-style-type: none"> • Clean the non-return valve. |
| Air in pump | <ul style="list-style-type: none"> • Vent the pump. |

10. Technical data

10.1 Operating conditions

| | |
|--------------------------|---|
| pH | APG pumps in permanent installations can cope with pH-values ranging from 4 to 10 |
| Liquid temperature | Liquid temperature: 0 °C to +40 °C For short periods up to +60 °C |
| Density of pumped liquid | Maximum density of pumped liquid: 1100 kg/m ³ |
| Installation depth | Maximum 10 metres below liquid level |
| Level of pumped liquid | The lowest stop level must always be above the top of the pump housing |
| Operation | Maximum 15 starts per hour |



The pumps are designed for intermittent operation only.



The sound pressure level of the pump is lower than the limiting values stated in the EC Council Directive 98/37/EEC relating to machinery.

11. Disposing of the product

This product or parts of it must be disposed of in an environmentally sound way.

1. Use the public or private waste collection service.
2. If this is not possible, contact the nearest Grundfos company or service workshop.



The crossed-out wheellie bin symbol on a product means that it must be disposed of separately from household waste. When a product marked with this symbol reaches its end of life, take it to a collection point designated by the local waste disposal authorities. The separate collection and recycling of such products will help protect the environment and human health.

See also end-of-life information at www.grundfos.com/product-recycling.

Argentina

Bombas GRUNDFOS de Argentina S.A.
Ruta Panamericana km. 37.500 Industrias
1619 - Garin Pcia. de B.A.
Tel.: +54-3327 414 444
Fax: +54-3327 45 3190

Australia

GRUNDFOS Pumps Pty. Ltd.
P.O. Box 2040
Regency Park
South Australia 5942
Tel.: +61-8-8461-4611
Fax: +61-8-8340-0155

Austria

GRUNDFOS Pumpen Vertrieb
Ges.m.b.H.
Grundfosstraße 2
A-5082 Grödig/Salzburg
Tel.: +43-6246-883-0
Fax: +43-6246-883-30

Belgium

N.V. GRUNDFOS Bellux S.A.
Boomssesteenweg 81-83
B-2630 Aartselaar
Tel.: +32-3-870 7300
Fax: +32-3-870 7301

Bosnia and Herzegovina

GRUNDFOS Sarajevo
Zmaja od Bosne 7-7A
BiH-71000 Sarajevo
Tel.: +387 33 592 480
Fax: +387 33 590 465
www.ba.grundfos.com
E-mail: grundfos@bih.net.ba

Brazil

BOMBAS GRUNDFOS DO BRASIL
Av. Humberto de Alencar Castelo
Branco, 630
CEP 09850 - 300
São Bernardo do Campo - SP
Tel.: +55-11 4393 5533
Fax: +55-11 4343 5015

Bulgaria

Grundfos Bulgaria EOOD
Slatina District
Iztocna Tangenta street no. 100
BG - 1592 Sofia
Tel.: +359 2 49 22 200
Fax: +359 2 49 22 201
E-mail: bulgaria@grundfos.bg

Canada

GRUNDFOS Canada inc.
2941 Brighton Road
Oakville, Ontario
L6H 6C9
Tel.: +1-905 829 9533
Fax: +1-905 829 9512

China

GRUNDFOS Pumps (Shanghai) Co. Ltd.
10F The Hub, No. 33 Suhong Road
Minhang District
Shanghai 201106 PRC
Tel.: +86 21 612 252 22
Fax: +86 21 612 253 33

Columbia

GRUNDFOS Colombia S.A.S.
Km 1.5 vía Siberia-Cota Conj. Potrero
Chico,
Parque Empresarial Arcos de Cota Bo. 1A.
Cota, Cundinamarca
Tel.: +57(1)-2913444
Fax: +57(1)-8764586

Croatia

GRUNDFOS CROATIA d.o.o.
Buzinski prilaz 38, Buzin
HR-10010 Zagreb
Tel.: +385 1 6595 400
Fax: +385 1 6595 499
www.hr.grundfos.com

Czech Republic

GRUNDFOS Sales Czechia and Slovakia
s.r.o.
Čajkovského 21
779 00 Olomouc
Tel.: +420-585-716 111

Denmark

GRUNDFOS DK A/S
Martin Bachs Vej 3
DK-8850 Bjerringbro
Tel.: +45-87 50 50 50
Fax: +45-87 50 51 51
E-mail: info_GDK@grundfos.com
www.grundfos.com/DK

Estonia

GRUNDFOS Pumps Eesti OÜ
Peterburi tee 92G
11415 Tallinn
Tel.: + 372 606 1690
Fax: + 372 606 1691

Finland

OY GRUNDFOS Pumput AB
Trukkikujua 1
FI-01360 Vantaa
Tel.: +358-(0) 207 889 500

France

Pompes GRUNDFOS Distribution S.A.
Parc d'Activités de Chesnes
57, rue de Malacombe
F-38290 St. Quentin Fallavier (Lyon)
Tel.: +33-4 74 82 15 15
Fax: +33-4 74 94 10 51

Germany

GRUNDFOS GMBH
Schlüterstr. 33
40699 Erkrath
Tel.: +49-(0) 211 929 69-0
Fax: +49-(0) 211 929 69-3799
E-mail: infoservice@grundfos.de
Service in Deutschland:
kundendienst@grundfos.de

Greece

GRUNDFOS Hellas A.E.B.E.
20th km. Athinon-Markopoulou Av.
P.O. Box 71
GR-19002 Peania
Tel.: +0030-210-66 83 400
Fax: +0030-210-66 46 273

Hong Kong

GRUNDFOS Pumps (Hong Kong) Ltd.
Unit 1, Ground floor, Siu Wai industrial
Centre
29-33 Wing Hong Street & 68 King Lam
Street, Cheung Sha Wan
Kowloon
Tel.: +852-27861706 / 27861741
Fax: +852-27858664

Hungary

GRUNDFOS Hungária Kft.
Tópark u. 8
H-2045 Törökbalint
Tel.: +36-23 511 110
Fax: +36-23 511 111

India

GRUNDFOS Pumps india Private Limited
118 Old Mahabalipuram Road
Thoraipakkam
Chennai 600 097
Tel.: +91-44 2496 6800

Indonesia

PT GRUNDFOS Pompa
Graha intrub Lt. 2 & 3
Jln. Cililitan Besar No.454. Makasar,
Jakarta Timur
ID-Jakarta 13650
Tel.: +62 21-469-51900
Fax: +62 21-460 6910 / 460 6901

Ireland

GRUNDFOS (Ireland) Ltd.
Unit A, Merrywell Business Park
Ballymount Road Lower
Dublin 12
Tel.: +353-1-4089 800
Fax: +353-1-4089 830

Italy

GRUNDFOS Pompe Italia S.r.l.
Via Gran Sasso 4
I-20060 Truccazzano (Milano)
Tel.: +39-02-95838112
Fax: +39-02-95309290 / 95838461

Japan

GRUNDFOS Pumps K.K.
1-2-3, Shin-Miyakoda, Kita-ku
Hamamatsu
431-2103 Japan
Tel.: +81 53 428 4760
Fax: +81 53 428 5005

Korea

GRUNDFOS Pumps Korea Ltd.
6th Floor, Aju Building 679-5
Yeoksam-dong, Kangnam-ku, 135-916
Seoul, Korea
Tel.: +82-2-5317 600
Fax: +82-2-5633 725

Latvia

SIA GRUNDFOS Pumps Latvia
Deglava biznesa centrs
Augusta Deglava ielā 60
LV-1035, Rīga,
Tel.: + 371 714 9640, 7 149 641
Fax: + 371 914 9646

Lithuania

GRUNDFOS Pumps UAB
Smolensko g. 6
LT-03201 Vilnius
Tel.: + 370 52 395 430
Fax: + 370 52 395 431

Malaysia

GRUNDFOS Pumps Sdn. Bhd.
7 Jalan Peguam U1/25
Glenmarie Industrial Park
40150 Shah Alam, Selangor
Tel.: +60-3-5569 2922
Fax: +60-3-5569 2866

Mexico

Bombas GRUNDFOS de México
S.A. de C.V.
Boulevard TLC No. 15
Parque industrial Stiva Aeropuerto
Apodaca, N.L. 66600
Tel.: +52-81-8144 4000
Fax: +52-81-8144 4010

Netherlands

GRUNDFOS Netherlands
Velluwezoom 35
1326 AE Almere
Postbus 22015
1302 CA ALMERE
Tel.: +31-88-478 6336
Fax: +31-88-478 6332
E-mail: info_gnl@grundfos.com

New Zealand

GRUNDFOS Pumps NZ Ltd.
17 Beatrice Tinsley Crescent
North Harbour Industrial Estate
Albany, Auckland
Tel.: +64-9-415 3240
Fax: +64-9-415 3250

Norway

GRUNDFOS Pumper A/S
Strømsveien 344
Postboks 235, Leirdal
N-1011 Oslo
Tel.: +47-22 90 47 00
Fax: +47-22 32 21 50

Poland

GRUNDFOS Pumpy Sp. z o.o.
ul. Klonowa 23
Baranowo k. Poznania
PL-62-081 Przeźmierowo
Tel.: (+48-61) 650 13 00
Fax: (+48-61) 650 13 50

Portugal

Bombas GRUNDFOS Portugal, S.A.
Rua Calvet de Magalhães, 241
Apartado 1079
P-2770-153 Paço de Arcos
Tel.: +351-21-440 76 00
Fax: +351-21-440 76 90

Romania

GRUNDFOS Pompe România SRL
S-PARK BUSINESS CENTER, Clădirea
A2, etaj 2
Str. Tipografilor, Nr. 11-15, Sector 1, Cod
013714
București, Romania
Tel.: 004 021 2004 100
E-mail: romania@grundfos.ro

Serbia

Grundfos Srbija d.o.o.
Omladinskih brigada 90b
11070 Novi Beograd
Tel.: +381 11 2258 740
Fax: +381 11 2281 769
www.rs.grundfos.com

Singapore

GRUNDFOS (Singapore) Pte. Ltd.
25 Jalan Tukang
Singapore 619264
Tel.: +65-6681 9688
Faxax: +65-6681 9689

Slovakia

GRUNDFOS s.r.o.
Prievozská 4D 821 09 BRATISLAVA
Tel.: +421 2 5020 1426
sk.grundfos.com

Slovenia

GRUNDFOS LJUBLJANA, d.o.o.
Leskoškova 9e, 1122 Ljubljana
Tel.: +386 (0) 1 568 06 10
Fax: +386 (0) 1 568 06 19
E-mail: tehnika-si@grundfos.com

South Africa

GRUNDFOS (PTY) LTD
16 Lascelles Drive, Meadowbrook Estate
1609 Germiston, Johannesburg
Tel.: (+27) 10 248 6000
Fax: (+27) 10 248 6002
E-mail: lgradidge@grundfos.com

Spain

Bombas GRUNDFOS España S.A.
Camino de la Fuentesilla, s/n
E-28110 Algete (Madrid)
Tel.: +34-91-848 8800
Fax: +34-91-628 0465

Sweden

GRUNDFOS AB
Box 333 (Lunnagårdsgatan 6)
431 24 Mölndal
Tel.: +46 31 332 23 000
Fax: +46 31 331 94 60

Switzerland

GRUNDFOS Pumpen AG
Bruggacherstrasse 10
CH-8117 Fällanden/ZH
Tel.: +41-44-806 8111
Fax: +41-44-806 8115

Taiwan

GRUNDFOS Pumps (Taiwan) Ltd.
7 Floor, 219 Min-Chuan Road
Taichung, Taiwan, R.O.C.
Tel.: +886-4-2305 0868
Fax: +886-4-2305 0878

Thailand

GRUNDFOS (Thailand) Ltd.
92 Chaloeem Phrakiat Rama 9 Road
Dokmai, Pravej, Bangkok 10250
Tel.: +66-2-725 8999
Fax: +66-2-725 8998

Turkey

GRUNDFOS POMPA San. ve Tic. Ltd.
Sti.
Gebze Organize Sanayi Bölgəsi
İhsan dede Caddesi
2. yol 200. Sokak No. 204
41490 Gebze/ Kocaeli
Tel.: +90 - 262-679 7979
Fax: +90 - 262-679 7905
E-mail: satis@grundfos.com

Ukraine

ТОВ "ГРУНДФОС УКРАЇНА"
Бізнес Центр Європа
Столичне шосе, 103
м. Київ, 03131, Україна
Tel.: (+38 044) 237 04 00
Fax: (+38 044) 237 04 01
E-mail: ukraine@grundfos.com

United Arab Emirates

GRUNDFOS Gulf Distribution
P.O. Box 16768
Jebel Ali Free Zone, Dubai
Tel.: +971 4 8815 166
Fax: +971 4 8815 136

United Kingdom

GRUNDFOS Pumps Ltd.
Grovebury Road
Leighton Buzzard/Beds. LU7 4TL
Tel.: +44-1525-850000
Fax: +44-1525-850011

U.S.A.

Global Headquarters for WU
856 Koomey Road
Brookshire, Texas 77423 USA
Phone: +1-630-236-5500

Uzbekistan

Grundfos Tashkent, Uzbekistan
The Representative Office of Grundfos
Kazakhstan in Uzbekistan
38a, Oybek street, Tashkent
Tel.: (+998) 71 150 3290 / 71 150 3291
Fax: (+998) 71 150 3292

| |
|-------------------------|
| 96434822 04.2023 |
|-------------------------|

| |
|--------------|
| ECM: 1271669 |
|--------------|

www.grundfos.com

GRUNDFOS 

Trademarks displayed in this material, including but not limited to Grundfos and the Grundfos logo, are registered trademarks owned by The Grundfos Group. © 2023 Grundfos Holding A/S, all rights reserved.