

GRUNDFOS DWK RANGE, 60 Hz  
Enduring and multifunctional



[grundfos.com/water-utility](http://grundfos.com/water-utility)

# SUBMERSIBLE CONTRACTOR PUMPS FOR DEWATERING AND DRAINAGE APPLICATIONS



BE > THINK > INNOVATE >

GRUNDFOS 

# DURABLE AND COMPACT DEWATERING PUMPS

## – designed for simplicity and use

*The DWK range of submersible contractor pumps from Grundfos combines durable performance with ease of installation, providing an immediate return on your dewatering solution investment.*

The solid cast iron construction and narrow design means the DWK range is ideal for pits, for temporary or fixed installation, in fact any situation where effective dewatering is needed.

If high-pressure pump performance unhindered by sand or other abrasives is required, or if the available power supply is limited, the DWK range provides the effective dewatering solution for you.

For full details on your options, go online. Everything you need to know is there. Begin at: [grundfos.com/water-utility](http://grundfos.com/water-utility)



---

## EFFECTIVE DEWATERING – when and where you need it

If you're a contractor working with building or infrastructure construction, the DWK range offers quality pump solutions that remove all rainwater and ground water from your construction area.

### **The DWK range offers you an immediate return on your dewatering solution investment**

- Underground drainage pits in buildings, where limited space and the need for high pressure matches the combination of motor size and pressure capabilities offered by the DWK range.
- Courts drainage solutions, with similar requirements for high pressure and limited space.
- Industrial applications, where water from various processes and functions is collected in drainage pits and then pumped onwards.
- In addition, the DWK-R version offers increased robustness where wear-resistance and maintained performance is required, for example building and infrastructure construction, tunnels and for industry.





[grundfos.com/water-utility](http://grundfos.com/water-utility)

# DWK PUMP FEATURES

## – and what they offer you

**Hose, storz or flange connection on the top**  
Top-discharge with different connection types available for multiple use of the pump, depending on conditions and specific needs.

**High efficiency motor**  
The long-life motor used in the DWK range keeps operating costs down and maintains even performance.

**Integrated thermal protection**  
The integrated circuit-cut protects the motor from overheating and operates independently, removing the need for constant monitoring.

**Easy maintenance oil plug**  
The ability to inspect oil condition in the seal chamber makes it easy for you to plan maintenance and service your pump.

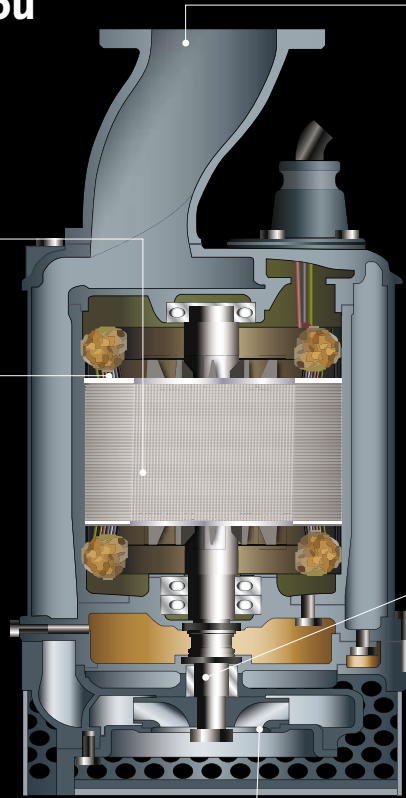

**Shaft seal**  
The triple-system sealing provides longer operation and less downtime, and consists of a double mechanical seal with an easily replaceable lip seal.

**Highly efficient and wear-resistant impeller**  
The stainless steel high-chrome impeller maintains its performance, ensuring an increased lifetime.

## Performance overview

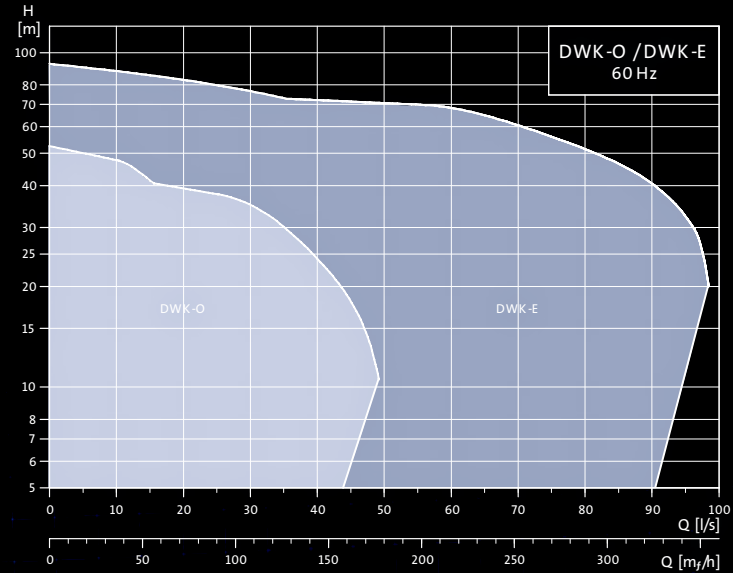

## SEE THE BIGGER PICTURE

Grundfos is a global leader within water handling technology. Our passion is to bring you all the products you require to create and operate pump systems that combine reliability, cost-efficiency – and innovation. Our products are for use in water supply and wastewater infrastructure on any scale.

Grundfos has a full line of products and systems for the intake, treatment and distribution of drinking water and for the transport and treatment of wastewater. We also offer expertise and industry insight that can increase reliability and reduce lifecycle costs for water utilities.

Key product areas include:



Submersible pumps



Surface pumps



Sewage pumps



Mixers, flowmakers & recirculation pumps



Pumping stations



Monitoring & controls



Dosing & disinfection



Aeration equipment

Our products are the result of decades of engineering expertise. Supported by a worldwide service network. Visit [grundfos.com/water-utility](http://grundfos.com/water-utility) for more.

### GRUNDFOS A/S

Poul Due Jensens Vej 7  
DK-8850 Bjerringbro  
Tel: +45 87 50 14 00

[www.grundfos.com](http://www.grundfos.com)

The name Grundfos, the Grundfos logo, and the payoff Be—Think—Innovate are registered trademarks owned by Grundfos Management A/S or Grundfos A/S, Denmark. All rights reserved worldwide.