

Service instructions

NB/NBG

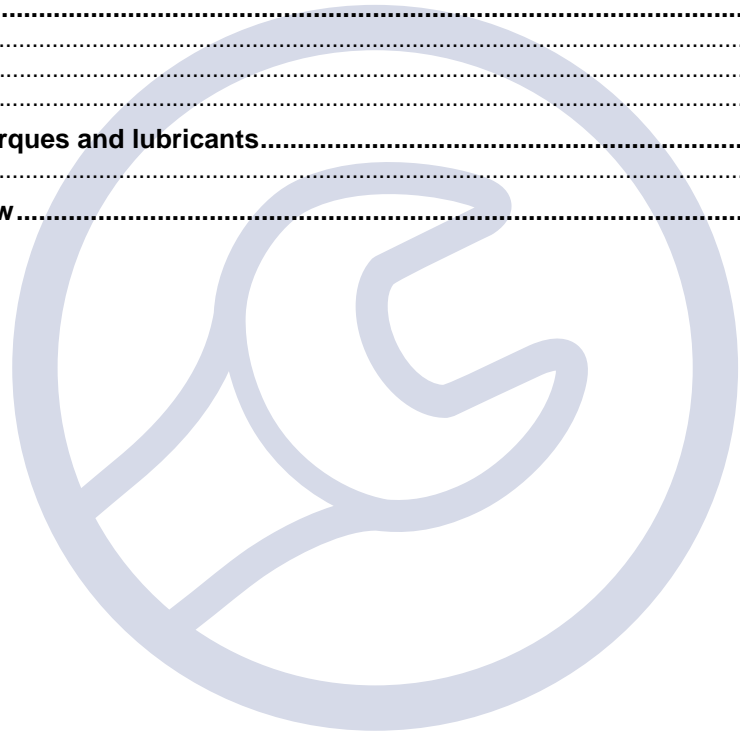

1.	Identification	2
1.1	Nameplate	2
1.2	Type key	3
1.3	Handling.....	4
2.	Dismantling and assembly	5
2.1	General information	5
2.2	Dismantling	5
2.3	Replacing the wear rings	6
2.4	Assembling the pump	6
3.	Fault finding	7
4.	Service tools	9
4.1	Special tools	9
4.2	Standard tools.....	10
4.3	Torque tools.....	10
5.	Tightening torques and lubricants.....	11
5.1	Lubrication	11
6.	Exploded view.....	12



1. Identification

1.1 Nameplate

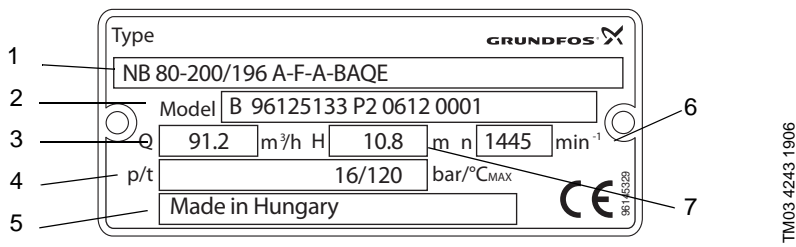

Fig. 1 Example of nameplate for NB

The example shows an NB 80-200 with 196 mm impeller, made of cast iron, with BAQE shaft seal and a 4-pole motor.

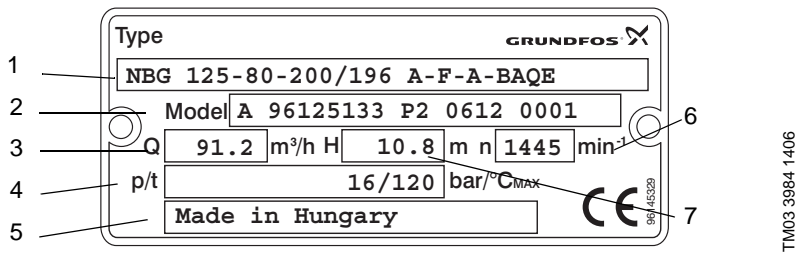

Fig. 2 Example of nameplate for NBG

The example shows an NBG 125-80-200 with 196 mm impeller, made of cast iron, with BAQE shaft seal and a 4-pole motor.

Pos.	Description
1	Type designation
2	Model
3	Rated flow rate, 50 Hz
4	Max. pressure/temperature
5	Place of production
6	Speed, 50 Hz
7	Head against closed valve, 50 Hz

1.2 Type key

NB

	NB	32	-125	.1	/142	A	-F	-A	-BAQE
Type range									
NB									
NBE									
Nominal diameter of discharge port (DN)									
Nominal impeller diameter [mm]									
Reduced performance = .1									
Actual impeller diameter [mm]									
Code for pump version (the codes can be combined*)									
A: Basic version									
B: Oversize or double-oversize motor									
C: Without motor									
D: Pump housing with feet									
E: With ATEX approval, certificate or test report									
X: Special version									
Code for pipe connection:									
F: DIN flange (EN 1092-2)									
Code for materials:									
A: Cast iron EN-GJL-250 pump housing, EN-GJL-250 impeller, bronze wear ring									
B: Cast iron EN-GJL-250 pump housing, bronze impeller CuSn10, bronze wear ring									
S: Cast iron EN-GJL-250 pump housing, 1.4408 impeller, bronze wear ring									
N: 1.4408 pump housing and impeller, carbon-graphite-filled PTFE wear ring									
R: 1.4517 pump housing and impeller, carbon-graphite-filled PTFE wear ring									
P: 1.4408 pump housing, 1.4517 impeller, carbon-graphite-filled PTFE wear ring									
K: 1.4408 pump housing and impeller, 1.4517 wear ring									
L: 1.4517 pump housing, impeller and wear ring									
M: 1.4408 pump housing, 1.4517 impeller and wear ring									
X: Special version									
Code for shaft seal and rubber pump parts									

* Examples of combined pump version codes:
 AE: Basic version with certificate or test report.
 BD: With oversize motor and pump housing with feet.
 CE: Without motor and with certificate and test report.

NBG

	NBG	50	-32	-125	.1	/142	A	-F	-A	-BAQE
Type range										
NBG										
NBGE										
Nominal diameter of suction port (DN)										
Nominal diameter of discharge port (DN)										
Nominal impeller diameter [mm]										
Reduced performance = .1										
Actual impeller diameter [mm]										
Code for pump version (the codes can be combined*)										
A: Basic version										
B: Oversize or double-oversize motor										
C: Without motor										
D: Pump housing with feet										
E: With ATEX approval, certificate or test report										
X: Special version										
Code for pipe connection:										
F: DIN flange (EN 1092-2)										
E: Table E flange										
Code for materials:										
A: Cast iron EN-GJL-250 pump housing, EN-GJL-250 impeller, bronze wear ring										
B: Cast iron EN-GJL-250 pump housing, bronze impeller CuSn10, bronze wear ring										
S: Cast iron EN-GJL-250 pump housing, 1.4408 impeller, bronze wear ring										
N: 1.4408 pump housing and impeller, carbon-graphite-filled PTFE wear ring										
R: 1.4517 pump housing and impeller, carbon-graphite-filled PTFE wear ring										
P: 1.4408 pump housing, 1.4517 impeller, carbon-graphite-filled PTFE wear ring										
K: 1.4408 pump housing and impeller, 1.4517 wear ring										
L: 1.4517 pump housing, impeller and wear ring										
M: 1.4408 pump housing, 1.4517 impeller and wear ring										
X: Special version										
Code for shaft seal and rubber pump parts										

Mechanical shaft seal

Shaft seal diameter [mm]	Code	Temperature range	28, 38	48	55	60
			Max. pressure [bar]			
Rubber bellows seal, metal-impregnated carbon/silicon carbide, EPDM	BAQE	0 °C to +120 °C	16	16	16	16
Rubber bellows seal, metal-impregnated carbon/silicon carbide, FKM	BAQV	0 °C to +90 °C	16	16	16	16
Rubber bellows seal, silicon carbide/silicon carbide, EPDM	BQQE	0 °C to +90 °C	16	16	16	16
Rubber bellows seal, silicon carbide/silicon carbide, FKM	BQQV	0 °C to +90 °C	16	16	16	16
Bellows seal, type B, with reduced seal faces, silicon carbide/silicon carbide, EPDM	GQQE	-25 °C to +90 °C	16	16*	16*	16*
Bellows seal, type B, with reduced seal faces, silicon carbide/silicon carbide, FKM	GQQV	-20 °C to +90 °C	16	16*	16*	16*
O-ring seal with fixed seal driver, silicon carbide/silicon carbide, EPDM	AQQE	0 °C to +90 °C	25	25	16	16
O-ring seal with fixed seal driver, silicon carbide/silicon carbide, FKM	AQQV	0 °C to +90 °C	25	25	16	16
O-ring seal with fixed seal driver, silicon carbide/metal-impregnated carbon, EPDM	AQAE	0 °C to +120 °C	25	25	25	25
O-ring seal with fixed seal driver, silicon carbide/metal-impregnated carbon, FKM	AQAV	0 °C to +90 °C	25	25	25	25
Rubber bellows seal, silicon carbide/resin-impregnated carbon, EPDM	BQBE	0 °C to +140 °C	16	-	-	-
O-ring seal, balanced, metal-impregnated carbon/silicon carbide, FXM	DAQF	0 °C to +140 °C	25	25	25	25
Rubber bellows seal, resin-impregnated carbon/silicon carbide, EPDM	BBQE	0 °C to +120 °C	16	16	16	16

* Maximum 60 °C

1.3 Handling



Warning

Pump motors as from 4 kW are supplied with lifting eyes which must not be used for lifting the entire pump unit. See fig. 4.

Pumps fitted with motors should be lifted by means of nylon straps and shackles, if required. See fig. 3.

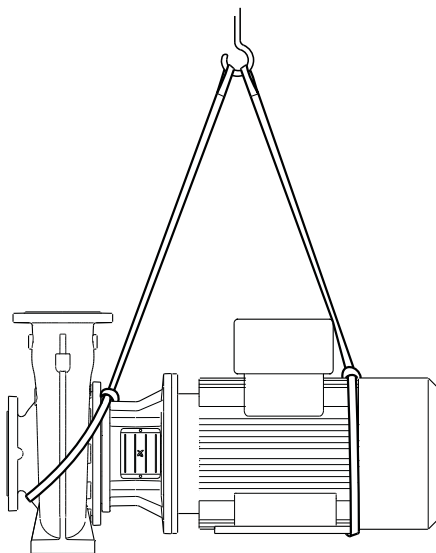

Fig. 3 Correct lifting of pump

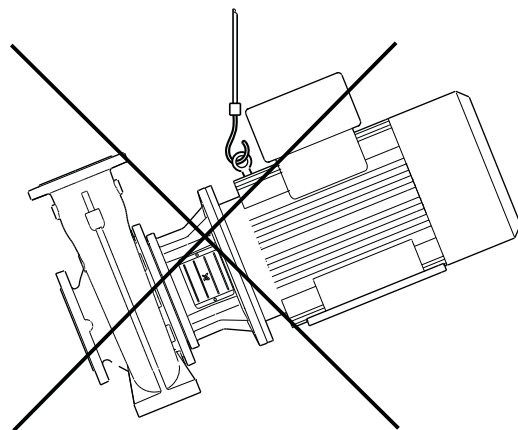

Fig. 4 Incorrect lifting of pump

2. Dismantling and assembly

2.1 General information

Follow these instructions if it is necessary to dismantle the pump, either because it is clogged or damaged.

Position numbers of parts (digits) refer to section 6. *Exploded view*; position numbers of service tools (letters) refer to section 4. *Service tools*.

Before dismantling

- Disconnect the electricity supply to the motor.
- Close the isolating valves, if fitted, to avoid draining the system.
- Remove the electric cable in accordance with local regulations.

Before assembly

- Order the necessary service kits.
- Clean and check all parts.
- Replace defective parts by new parts.
- Always replace gaskets and O-rings when the pump is serviced.

During assembly

- Lubricate and tighten screws and nuts to correct torque. See section 5. *Tightening torques and lubricants*.

2.2 Dismantling

1. Remove the nuts (pos. 36) from the pump housing (pos. 6).
 2. Remove the pump housing. It may be necessary to use a plastic hammer (pos. I) or a pinch bar (pos. F) for separating the pump housing from the motor stool (pos. 1a) or cover (pos. 77).
 3. Remove the O-ring (pos. 72a) from the motor stool/cover.
 4. Hold the impeller with a strap wrench (pos. D), and slacken the impeller nut (pos. 67). Remove the impeller nut, spring washer (pos. 66a) and washer (pos. 66) from the shaft.
 5. Remove the impeller (pos. 49) using a puller.
 6. Remove the key (pos. 11) from the shaft (pos. 51).
 7. Remove the spacer rings, if any, between impeller and shaft seal (pos. 105).
- 8. Shaft seal, types MG13 and HJ92:**
- Pull off the rotating shaft seal part using two screwdrivers.
- Shaft seal, type M7N:**
- First, pull off the spring retainer using two screwdrivers. Next, remove the seal ring with O-ring using two screwdrivers.
- 9. Pump with separate motor stool (pos. 1a) and clamped cover (pos. 77):**
- Remove the cover.
- Pump with separate motor stool (pos. 1a) and screw-fixed cover (pos. 77):**
- Remove the screws holding cover and motor stool together, and pull off the cover.
- Pump with integrated motor stool/cover (pos. 2):**
- Remove the coupling guards (pos. 7) and the screws/nuts holding the motor stool (pos. 28 and 36a) and motor together. Remove the motor stool (pos. 2). It may be necessary to loosen the motor stool from the motor with a plastic hammer.
10. Remove the stationary shaft seal part by pushing it from the back.
 11. Slacken the screws (pos. 9) fixing the pump shaft (pos. 51) on the motor shaft.
 12. Remove the pump shaft. It may be necessary to loosen it with a pinch bar or similar tool.

2.3 Replacing the wear rings

Pump with bronze wear rings

1. Insert the hook of the puller (pos. C) under the wear ring (pos. 45 or 45b).
2. Knock the impact block against the puller end stop. Move the puller to another position under the wear ring.
3. Knock the new wear ring home using a piece of wood as a buffer.
4. Repeat steps 1 to 3 for the second wear ring of the pump.

Pump with stainless steel wear rings

1. Unscrew the screws (pos. 24 and 24b) of both wear rings (pos. 45 and 45b), and remove the wear rings.
2. Fit new wear rings, and tighten the screws to the correct torque.

Pump with stainless steel/carbon-graphite-filled wear rings

1. Unscrew the screws (pos. 24 and 24b) of both wear ring retainers (pos. 65 and 65b), and remove the wear ring retainers.
2. Push the carbon-graphite-filled wear rings (pos. 45 and 45b) out of the wear ring retainers.
3. Fit new carbon-graphite-filled wear rings in the wear ring retainers.
4. Fit the wear rings/wear ring retainers, and tighten the screws to the correct torque.

2.4 Assembling the pump

1. Lubricate the motor shaft with O-ring grease.
2. Push the pump shaft (pos. 51) home on the motor shaft. Make sure that the pump shaft does not move when you release it.
3. Apply a drop of Loctite 243 to the set screws (pos. 9), and tighten them into the pump shaft to the correct torque.
4. Fit the motor stool (pos. 1a or 2) on the motor.
5. Fit the screws/nuts (pos. 28 and 36a) on the motor stool, and tighten them to the correct torque.
6. Fit the mounting bush (pos. A) on the pump shaft.
7. **Pump with separate motor stool (pos. 1a) and clamped cover (pos. 77):**
 - Fit the cover to the motor stool.
8. **Pump with separate motor stool (pos. 1a) and screw-fixed cover (pos. 77):**
 - Fit the cover to the motor stool, and tighten it to the correct torque.
9. Spray soapy water on the pump shaft and the mounting bush.
10. Fit the stationary shaft seal part (pos. 105) on the shaft. Do not touch the seal face with your fingers.
11. Press the stationary shaft seal part home using a punch of soft material (pos. B).
11. **Shaft seal, types HJ92 and M7N:**
 - Remove the screws, if any, from the rotating shaft seal part, and discard them.
12. Spray soapy water on the rotating shaft seal part.
13. Press the rotating shaft seal part home using a punch of soft material (pos. B).
14. Fit spacer rings, if required, between shaft seal and impeller on the pump shaft.
15. Remove the mounting bush (pos. A) from the pump shaft.
16. Fit the key (pos. 11) and the impeller (pos. 49) on the shaft.
17. Fit the washer (pos. 66), spring washer (pos. 66a) and impeller nut (pos. 67).
18. Hold the impeller with a strap wrench, and tighten the impeller nut to the correct torque.
19. Fit the O-ring (pos. 72a) on the cover, and lubricate it.
20. Fit the pump housing (pos. 6).
21. Fasten the cover/motor stool on the pump housing by cross-tightening the nuts (pos. 36) to the correct torque.
22. Check that the pump shaft can rotate freely.
23. Fit the coupling guards (pos. 7), and tighten the screws to the correct torque.

3. Fault finding



Warning

Before removing the terminal box cover and before any dismantling of the pump, make sure that the electricity supply has been switched off. It must be ensured that it cannot be accidentally switched on.

Fault	Cause	Remedy
1. The pump delivers no or too little liquid.	a) Wrong electrical connection (2 phases).	Check the electrical connection, and remedy, if necessary.
	b) Wrong direction of rotation.	Interchange two phases of the mains supply.
	c) Air in suction pipe.	Vent the suction pipe or the pump, and replenish.
	d) Counter-pressure too high.	Set the duty point in accordance with the data sheet. Check the system for impurities.
	e) Inlet pressure too low.	Increase the liquid level on the suction side. Open the isolating valve in the suction pipe. See the installation and operating instructions.
	f) Suction pipe blocked, or impurities in impeller.	Clean the pump.
	g) Pump draws in air due to defective seal.	Check the pipeline seals, pump housing gaskets and shaft seals, and replace, if necessary.
	h) Pump draws in air due to low liquid level.	Increase the liquid level on the suction side, and keep it as constant as possible.
2. The motor-protective circuit breaker has tripped because the motor is overloaded.	a) Pump blocked by impurities.	Clean the pump.
	b) Pump running above the rated duty point.	Set the duty point in accordance with the data sheet.
	c) Density or viscosity of the liquid is higher than specified when ordering.	If less flow is sufficient, reduce the flow on the discharge side. Or fit a more powerful motor.
	d) Motor starter overload setting is incorrect.	Check the setting of the motor-protective circuit breaker, and replace, if necessary.
	e) The motor runs on two phases.	Check the electrical connection. Replace the fuse, if defective.
3. Pump makes too much noise. Pump runs unevenly and vibrates.	a) Inlet pressure too low (cavitation).	Increase the liquid level on the suction side. Open the isolating valve in the suction pipe. See the installation and operating instructions.
	b) Air in suction pipe or pump.	Vent the suction pipe or the pump, and replenish.
	c) Counter-pressure is lower than specified.	Set the duty point in accordance with the data sheet.
	d) Pump draws in air due to low liquid level.	Increase the liquid level on the suction side, and keep it as constant as possible.
	e) Impeller out of balance (clogged impeller blades).	Clean and check the impeller.
	f) Inner parts worn.	Replace defective parts.
	g) Pump stressed by the pipework (thus causing starting noise).	Mount the pump so that it is not stressed. Support the pipes.
	h) Defective bearings.	Replace the bearings.
	i) Defective motor fan.	Replace the fan.
	j) Foreign bodies in the pump.	Clean the pump.
	k) Frequency converter operation.	See the installation and operating instructions.
4. Leakage in pump or at connections. Leakage in mechanical shaft seal.	a) Pump stressed by the pipework (thus causing leaks in the pump or at connections).	Mount the pump so that it is not stressed. Support the pipes.
	b) Pump housing gaskets and gaskets at connections defective.	Replace pump housing gaskets or gaskets at connections.
	c) Mechanical shaft seal dirty or stuck together.	Check and clean the mechanical shaft seal.
	d) Mechanical shaft seal defective.	Replace the mechanical shaft seal.
	e) Shaft surface defective.	Replace the shaft.

Fault	Cause	Remedy
5. Too high temperature in pump or motor.	a) Air in suction pipe or pump.	Vent the suction pipe or the pump, and replenish.
	b) Inlet pressure too low.	Increase the liquid level on the suction side. Open the isolating valve in the suction pipe. See the installation and operating instructions.
	c) Bearings lubricated with too little, too much or unsuitable lubricant.	Replenish, reduce or replace lubricant.
	d) Axial pressure too high.	Check the relief holes of the impeller and the lock rings on the suction side.
	e) Motor-protective circuit breaker is defective, or setting is incorrect.	Check the setting of the motor-protective circuit breaker, and replace, if necessary.
	f) The motor is overloaded.	Reduce the flow rate.

4. Service tools

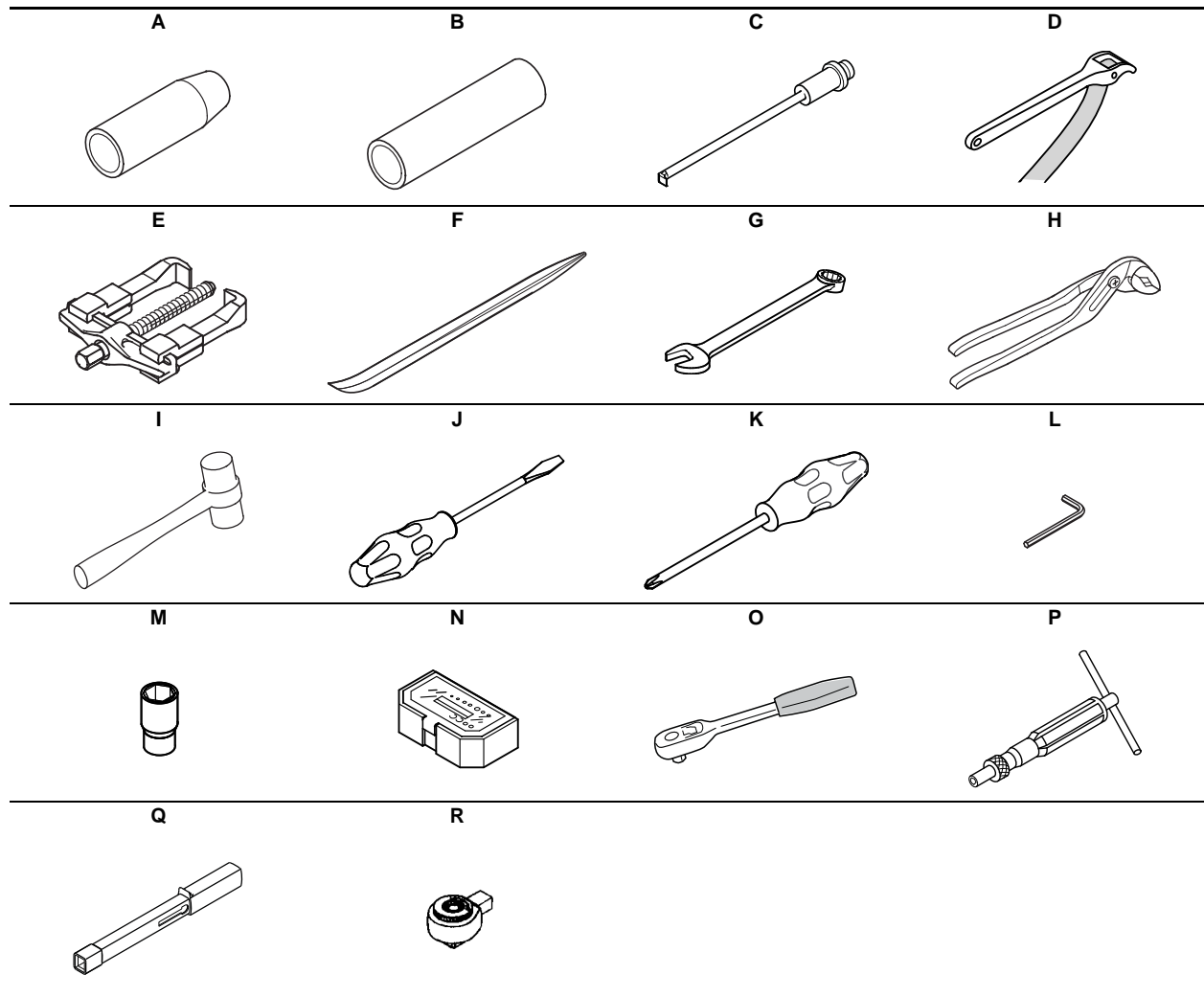

4.1 Special tools

Pos.	Description	For pos.	Further information	Part number
A	Protective sleeve	105	d28	V7216304
			d38	V7216305
			d48	70007165
			d55	70007166
			d60	70007167
B	Punch for shaft seal	105	d28	V7216306
			d38	V7216307
			d48	70007172
			d55	70007173
C	Puller for wear ring	45, 45b	d60	70007174
				96824962

4.2 Standard tools

Pos.	Description	For pos.	Further information	Part number
D	Strap wrench	49		00SV0853
E	Puller	49		
F	Pinch bar	51		SV5201
G	Ring/open-end spanner	36, 36a, 67	17 mm	SV0056
			19 mm	SV0063
			22 mm	00SV0186
			24 mm	SV0122
			30 mm	SV0073
	36 mm			
H	Polygrip pliers	11		SV0150
I	Plastic hammer	2, 77		SV0349
J	Screwdriver	105		
K	Cross-recess screwdriver	7a		
L	Hexagon key	9, 9a	2.5 mm	SV0277
			3 mm	
			4 mm	SV0278
			6 mm	SV0196
	10 mm		SV0033	
M	Hexagon socket	36, 36a, 67	13 mm	SV0413
			17 mm	SV0417
			19 mm	SV0419
			22 mm	SV0422
			24 mm	SV0424
			27 mm	SV0427
			30 mm	
			36 mm	
	41 mm			
	50 mm			
N	Bits kit	7a, 9, 9a		SV2010
O	Ratchet handle	M		96777072

4.3 Torque tools

Pos.	Description	For pos.	Further information	Part number
P	Torque screwdriver	N	1-6 Nm	SV0438
Q	Torque wrench	Q	9 x12 mm - 4-20 Nm	SV2092
			9 x12 mm - 20-100 Nm	SV0269
			14 x18 mm - 40-200 Nm	SV0400
R	Ratchet insert tool	M	9 x12 mm - 1/2"	SV0295
			14 x 18 mm	SV0401

5. Tightening torques and lubricants

Pos.	Description	Quantity	Dimensions	Torque [Nm]	Lubricant
7a	Screw	4	M5	6 ± 2	
9	Set screw	2, 3	M5	6 ± 1	Loctite 243
			M6	8 ± 2	
			M8	15 ± 3	
9a	Hexagon socket head screw	6	M8	30 ± 3	
			8	M12	
17a	Air vent screw	1	G1/8"	8 ± 2	
20	Integrated motor stool: Pipe plug	2, 4	3/8"	25 ± 5	Loctite 243
			1/2"	30 ± 7	
20	Separate motor stool: Pipe plug	2, 4	3/8"	25 ± 6	Loctite 243
			1/2"	35 ± 7	
24, 24b	Hexagon socket head screw	2 x 4	M5	5 ± 0.5	
			M10	45 ± 9	
26	Staybolt	6, 8, 10	M12	80 ± 16	
			M16	145 ± 30	
			M24	200 ± 40	
			M10	45 ± 9	
36	Nut	6, 8, 10	M12	80 ± 16	
			M16	145 ± 30	
			M24	200 ± 40	
			M10	45 ± 9	
36a	Nut	6, 8, 10	M8	12 ± 2.4	
			M10	25 ± 5	
			M12	40 ± 8	
			M16	100 ± 20	
			M20	150 ± 30	
			M24	200 ± 40	
67	Nut	1	M14	70 ± 7	
			M18	155 ± 15	
			M24	375 ± 35	
			M27	375 ± 35	
			M33	375 ± 35	
72a	O-ring	1			Soapy water
105	Shaft seal	1			Soapy water

5.1 Lubrication

Motor bearings

Motors up to and including frame size 160 have maintenance-free, greased-for-life bearings.

Motors of frame sizes larger than 160 should be greased according to the indications on the motor nameplate.

Grease spills from the motor may occur.

Specifications of grease, see section 5.1.1 *Bearing grease*.

5.1.1 Bearing grease

Lithium-based grease according to the following specifications must be used:

- NLGI class 2 or 3.
- Viscosity of basic oil: 70 to 150 mm²/s at +40 °C.
- Temperature range: –30 °C to +140 °C during continuous operation.

6. Exploded view

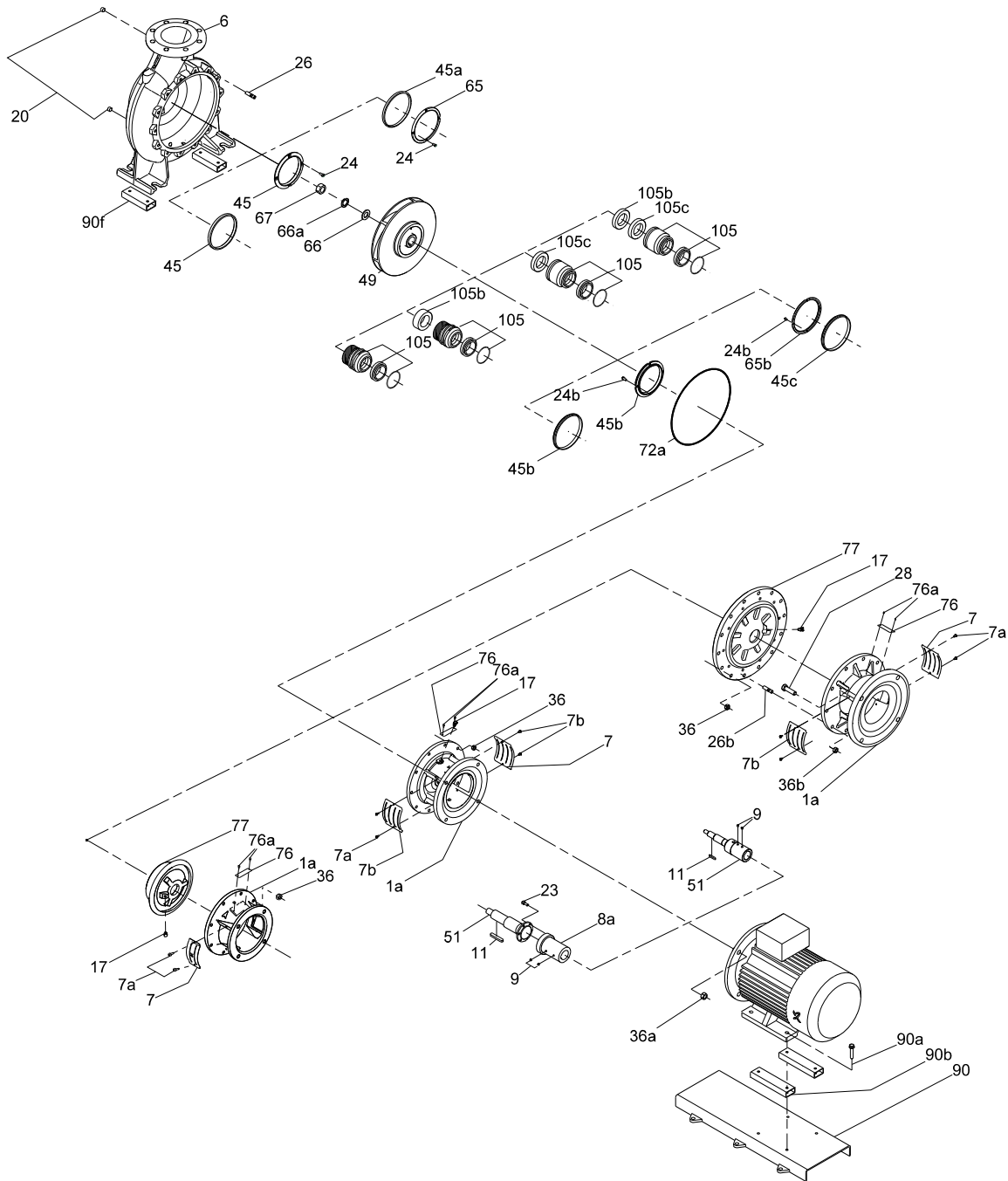

Fig. 5 Exploded view

TM03 6013 2009

Subject to alterations.